

FMI

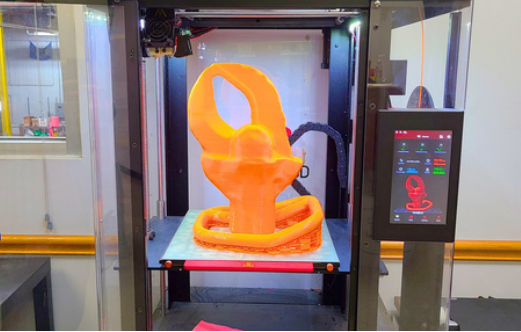

Fire Manufacturing Innovations



OUR MISSION













To protect people who serve by creating safer vehicle access solutions.

FMI, designs, manufactures, and installs compartment management solutions. Our solutions ensure that we are the best design partner and engineered solutions manufacturer in the specialized vehicle market.

OUR FACILITY

Our state-of-the-art facility includes multiple Trumpf lasers and bending machines, 3D printers, welding stations and a full paint facility. FMI's use of industry leading technology allows us to deliver innovative, cost-effective compartment management solutions.

TABLE OF CONTENTS

 FMI SuZan™	4
 Map Boxes	6
 Extinguisher Tilt Outs	10
 Oil Dry Hoppers	12
 Cup Holders	15
 Saw Accessories	20
 Glove Boxes	22
 Air Bag Controller Totes	27
 Tool Board Swingout	28
 Shelving	32
 EMS Cabinets	34
 Brackets	35

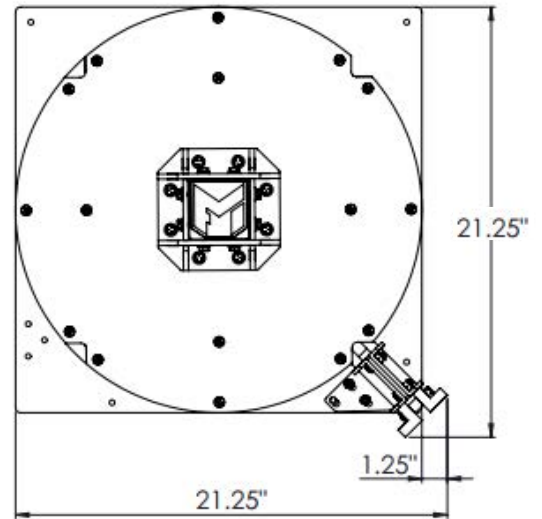
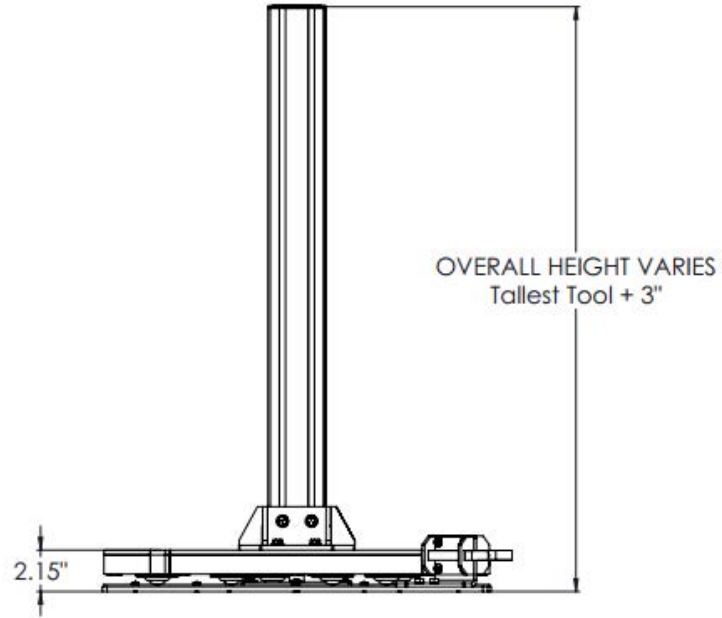

Features:

- Accommodates all name brand extrication tools
- FMI SuZan™ spins for easy access to all mounted tools
- Sturdy quick release mounts and brackets with a lifetime warranty
- Optional slide-out (Rated up to 600 lbs.)

Type	Part #	Dimensions	Tool Mounts	Weight	Slide-out Available
20 Inch FMI SuZan™	FMI-10020-LS	21.25 W x 21.25 D x 30.15 H in. (Finished assembly requires a 3 in. clearance from tallest tool)	1-4	54 lbs.	Yes (Add 3 inches to height and 47 lbs.)

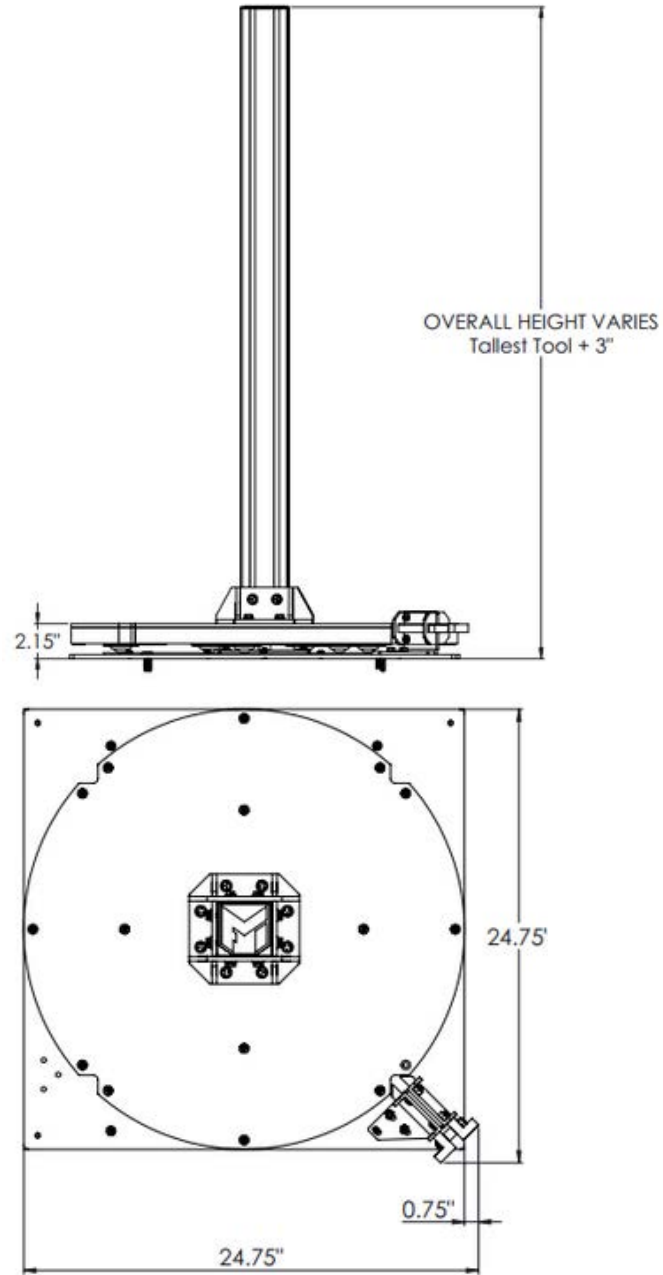

Features:

- Accommodates all name brand extrication tools
- FMI SuZan™ spins for easy access to all mounted tools
- Sturdy quick release mounts and brackets with a lifetime warranty
- Optional slide-out (Rated up to 600 lbs.)

Type	Part #	Dimensions	Tool Mounts	Weight	Slide-out Available
24 Inch FMI SuZan™	FMI-10024-LS	24.75 W x 24.75 D x 30.15 H in. (Finished assembly requires a 3 in. clearance from tallest tool)	1-4	66 lbs.	Yes (Add 3 inches to height and 65 lbs.)



Flat 2 Divider Map Box

Map Boxes



- Mounting hardware not included

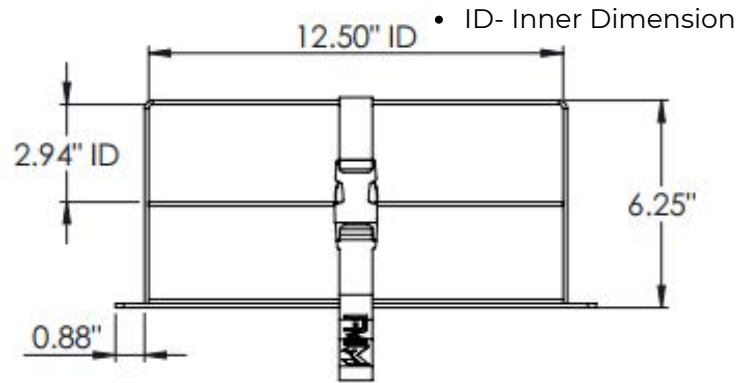
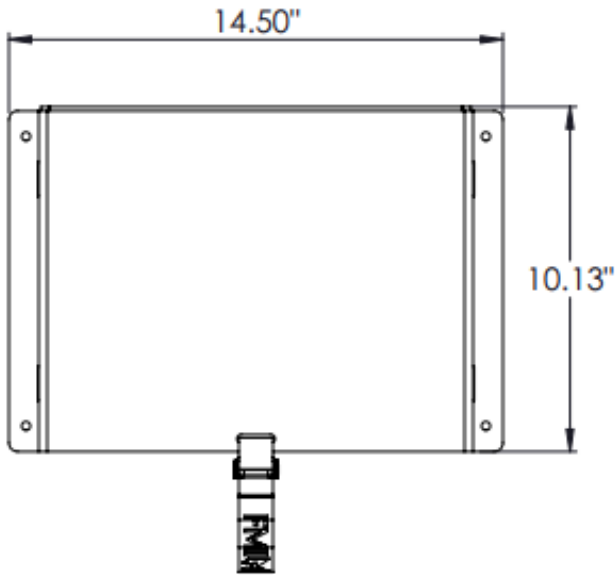

Features:

- 2 pockets (2.94 in. ID) for easy storage
- Adjustable strap allows for secure storage of material

Type	Part #	Dimensions	Weight	Pockets	Colors
2 Divider Map Box	FMI-51000	14.5 W x 10.13 D x 6.25 H in.	7.6 lbs.	2	Black Raptor Gray Raptor DA Finish



- Mounting hardware not included

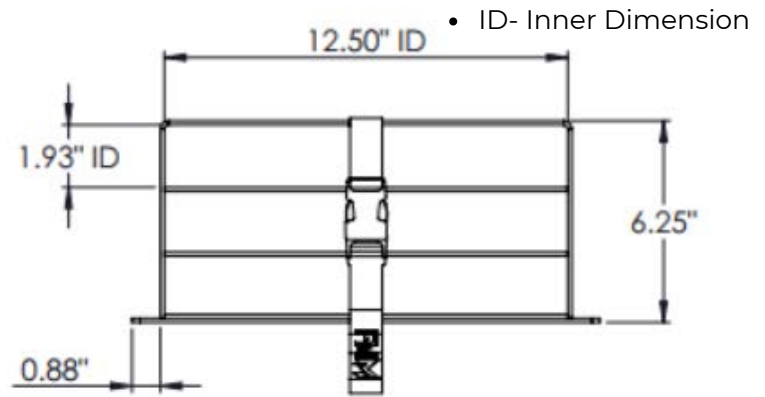
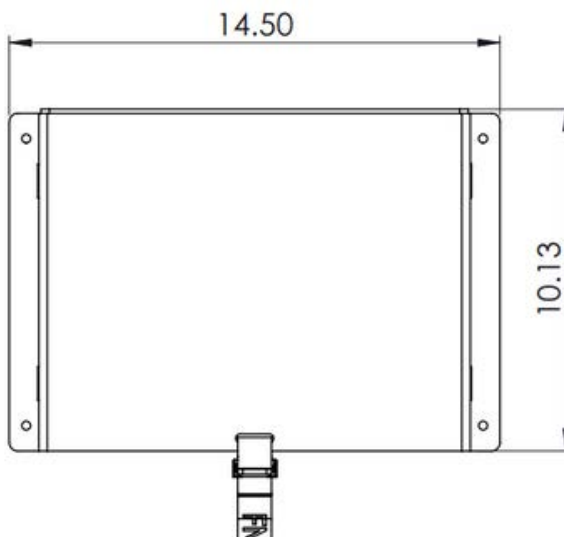

Features:

- 3 pockets (1.93 in. ID) for easy storage
- Adjustable strap allows for secure storage of material

Type	Part #	Dimensions	Weight	Pockets	Colors
3-Divider Horizontal Map Box	FMI-51005	14.5 W x 10.13 D x 6.25 H in.	8.75 lbs.	3	Black Raptor Gray Raptor DA Finish



5 Divider Map Box with Cup Holders

Map Boxes



- Mounting hardware not included

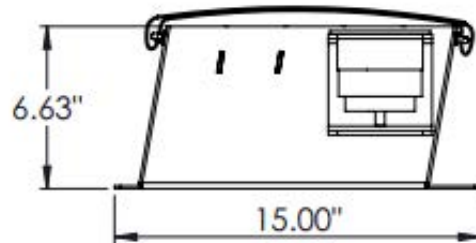
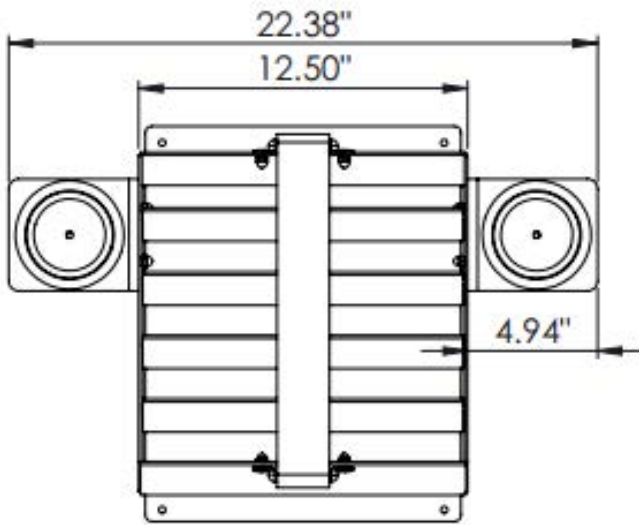

Features:

- 2 cup holders (3.25 in. ID)
- 5 pockets for storage (2.5 in. ID)
- Removable cup holder allows for easy cleaning
- Adjustable strap allows for the secure storage of material

Type	Part #	Dimensions	Weight	Pockets	Colors
5 Slot Map Box with Dual C-shaped Cup Holders	FMI-51100	22.38 W x 15.00 D x 6.63 H in.	12.2 lbs	5	Black Raptor Gray Raptor DA Finish



- Mounting hardware not included

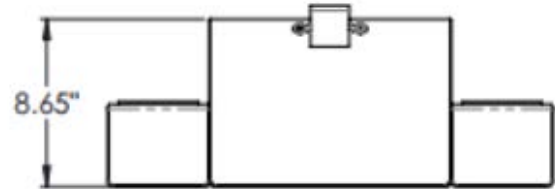
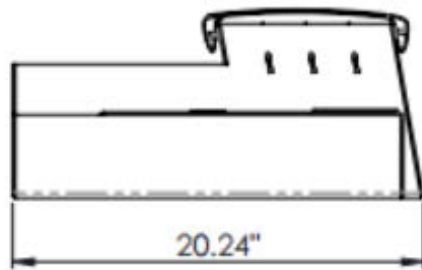
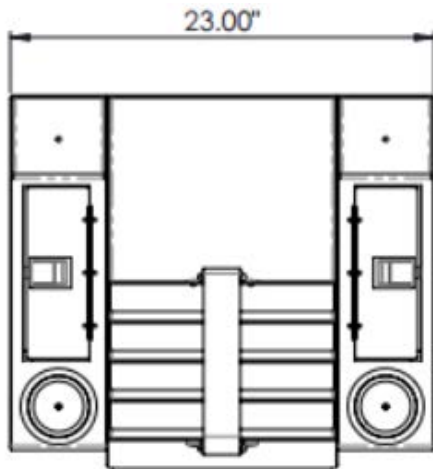

Features:

- 2 cup holders (3.25 in. ID)
- 4 pockets for dividers (2 in. ID)
- Removable cup holder allows for easy cleaning
- 2 enclosed storage compartments for small items
- Adjustable strap allows for the secure storage of material

Type	Part #	Dimensions	Weight	Pockets	Colors
Dual Hinged Map Box	FMI-51150	23.00 W x 20.24 D x 8.65 H in.	25.4 lbs.	4	Black Raptor Gray Raptor DA Finish



- Mounting hardware not included

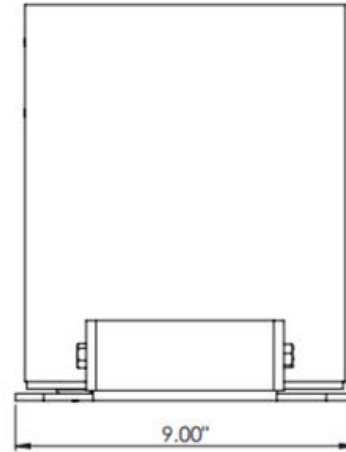
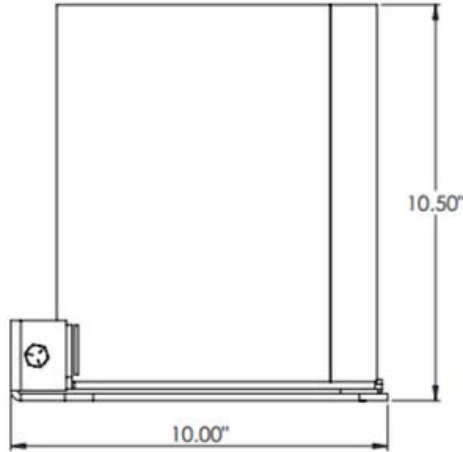

Features:

- 3/16" Aluminum frame is incredibly durable
- Tips forward for easy storage and retrieval of up to 8" diameter extinguishers

Type	Part #	Dimensions	Weight	Extinguishers
Single Extinguisher Tilt Out	FMI-30000-STO	9.0 W x 10.0 D x 10.5 H in.	8.0 lbs.	1



Double Extinguisher Tilt Out

Extinguisher Tilt Outs



- Mounting hardware not included

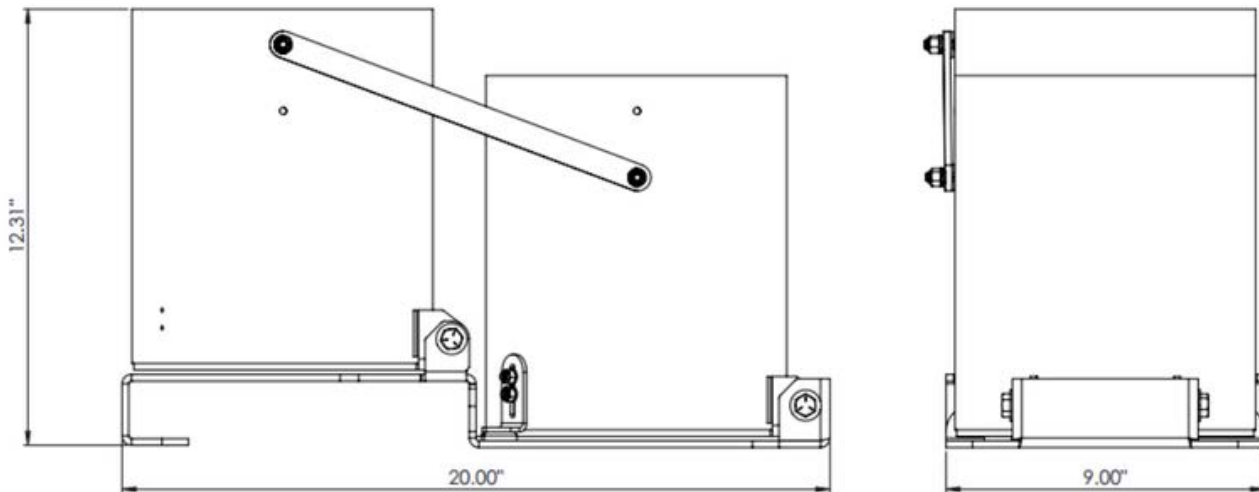

Features:

- 3/16" Aluminum frame is incredibly durable
- Tips forward for easy storage and retrieval of up to 8" diameter extinguishers

Type	Part #	Dimensions	Weight	Extinguishers
Double Extinguisher Tilt Out	FMI-30100-DTO	9.0 W x 20.0 D x 12.31 H in.	16.6 lb.	2



20 in. Shelf Mounted Hopper

Oil Dry
Hoppers

Requires: Adjustable Shelf Kit (FMI-41001)



- Mounting angles are included

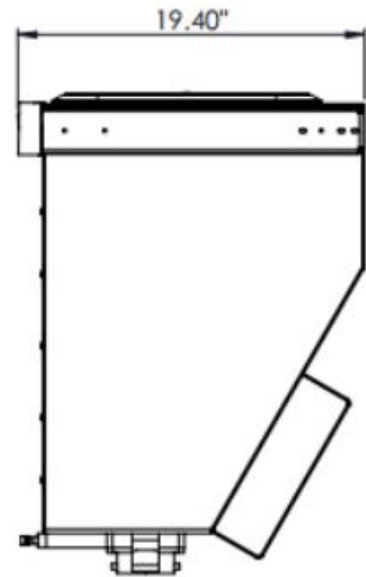
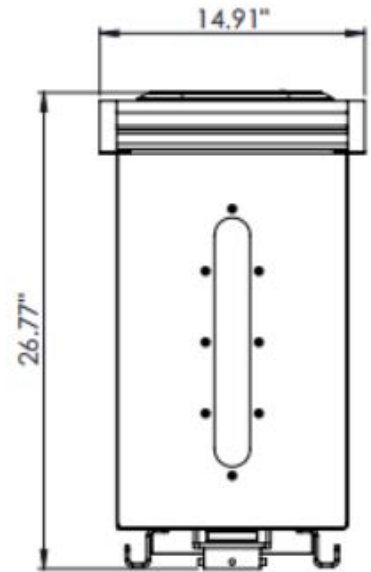

Features:

- Top latch keeps contents secure
- Mounted on drawer slides for easy access
- Handle activated gate valve for dispensing

Type	Part #	Dimensions	Weight	Colors	Optional Collapsible Bucket
Oil Dry Hopper for 20 in. Compartment 2.5 Cubic ft.	FMI-21001	14.91 W x 19.40 D x 26.77 H in.	38.2 lbs.	Black Raptor Gray Raptor DA Finish	Yes



24 in. Shelf Mounted Hopper

Oil Dry Hoppers

Requires: Adjustable Shelf Kit (FMI-41001)



- Mounting angles are included

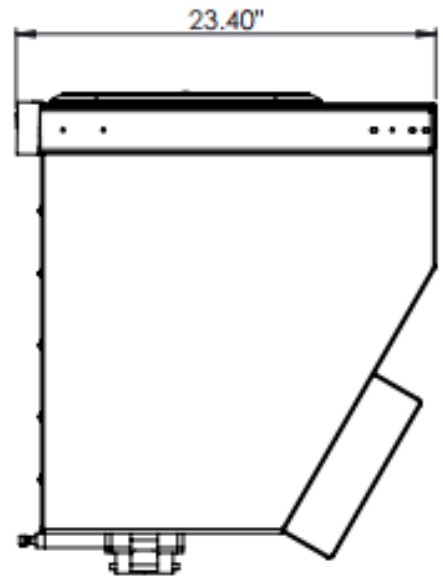
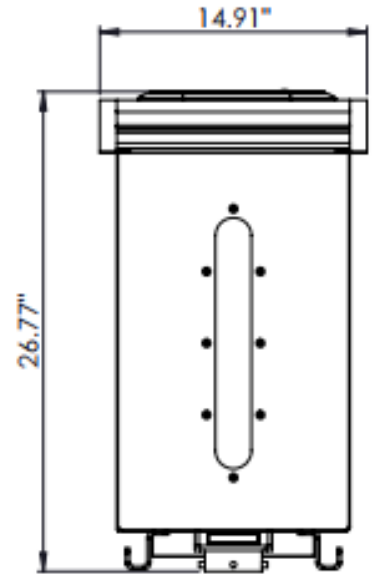

Features:

- Top latch keeps contents secure
- Mounted on drawer slides for easy access
- Handle activated gate valve for dispensing

Type	Part #	Dimensions	Weight	Colors	Optional Collapsible Bucket
Oil Dry Hopper for 24 in. Compartment 3.2 Cubic ft.	FMI-21002	14.91 W x 23.40 D x 26.77 H in.	44.4 lbs.	Black Raptor Gray Raptor DA Finish	Yes



26 in. Shelf Mounted Hopper

Oil Dry Hoppers

Requires: Adjustable Shelf Kit (FMI-41001)



- Mounting angles are included

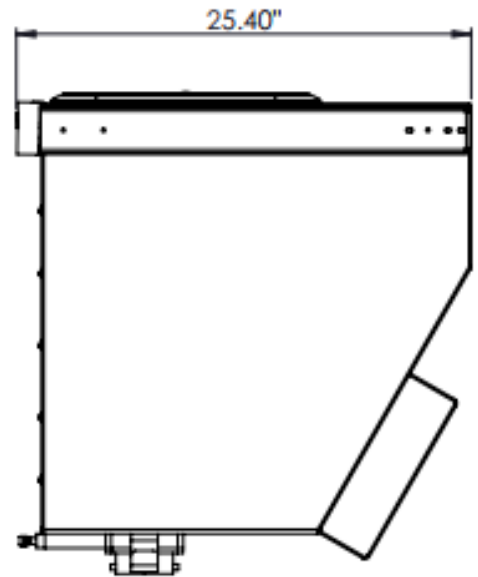
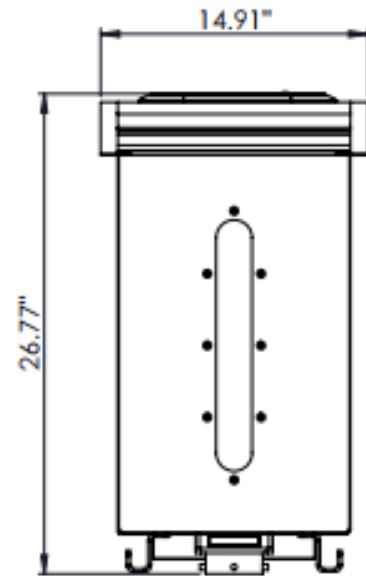

Features:

- Top latch keeps contents secure
- Mounted on drawer slidse for easy access
- Handle activated gate valve for dispensing

Type	Part #	Dimensions	Weight	Colors	Optional Collapsible Bucket
Oil Dry Hopper for 26 in. Compartment 3.5 Cubic ft.	FMI-21003	14.91 W x 25.40 D x 26.77 H in.	46.8 lbs.	Black Raptor Gray Raptor DA Finish	Yes



- Mounting hardware not included

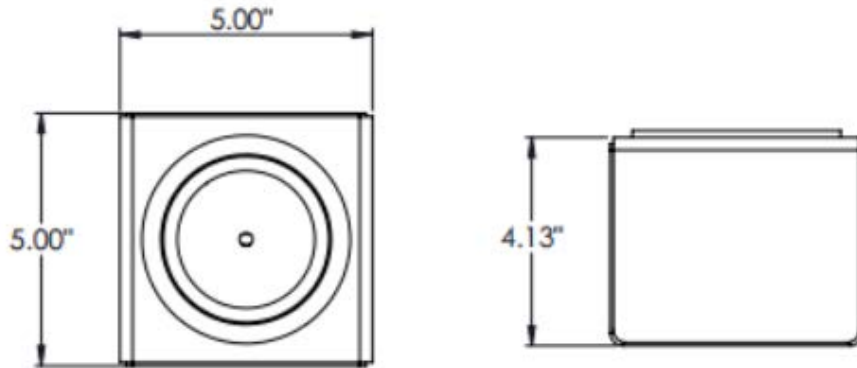

Features:

- 1 cup holder (3.25 in. ID)
- Removable cup holder allows for easy cleaning

Type	Part #	Dimensions	Weight	Colors
Enclosed Cup Holder, Single	FMI-52000	5.00 W x 5.00 D x 4.13 H in.	1.4 lbs.	Black Raptor Gray Raptor DA Finish



- Mounting hardware not included

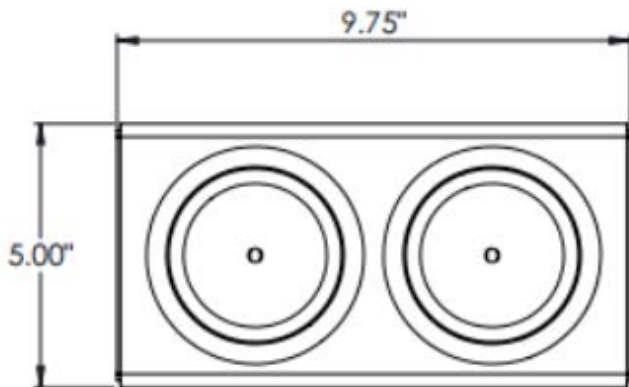

Features:

- 2 cup holders (3.25 in. ID)
- Removable cup holders allow for easy cleaning

Type	Part #	Dimensions	Weight	Colors
Enclosed Cup Holder, Double	FMI-52005	9.75 W x 5.00 D x 4.13 H in.	2.4 lbs.	Black Raptor Gray Raptor DA Finish



- Mounting hardware not included

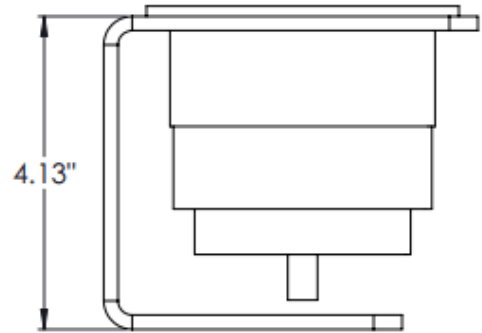
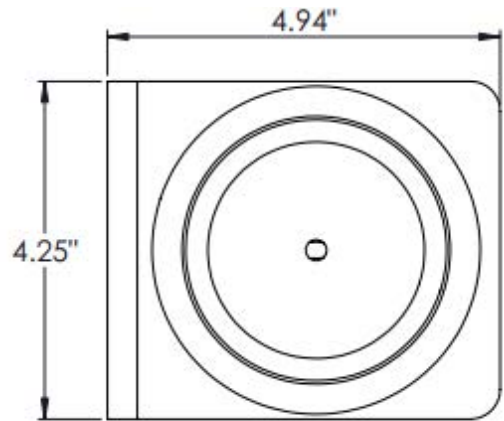

Features:

- 1 cup holder (3.25 in. ID)
- C shape allows for wall mounting

Type	Part #	Dimensions	Weight	Colors
C-Shape Open Side Cup Holder, Single	FMI-52010	4.25 W x 4.94 D x 4.13 H in.	0.8 lbs.	Black Raptor Gray Raptor DA Finish



- Mounting hardware not included

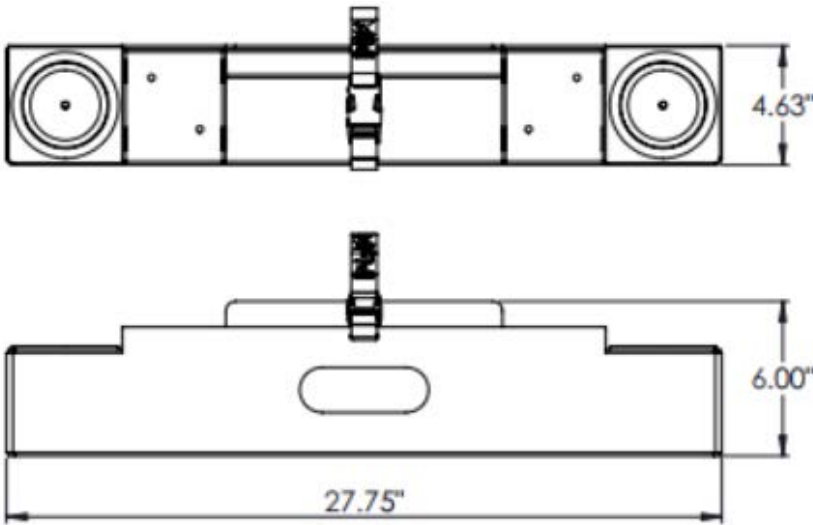

Features:

- 2 pockets for storage
- 2 cup holders (3.25 in. ID)
- Strap allows for secure storage of tablet.

Type	Part #	Dimensions	Weight	Pockets	Colors
Glove Box, Tablet Holder Dual Cup Holder	FMI-52015	27.75 W x 4.63 D x 6.0 H in.	7.6 lbs.	2	Black Raptor Gray Raptor DA Finish



Hinged Storage Cup Holder

Cup Holders



- Mounting hardware not included

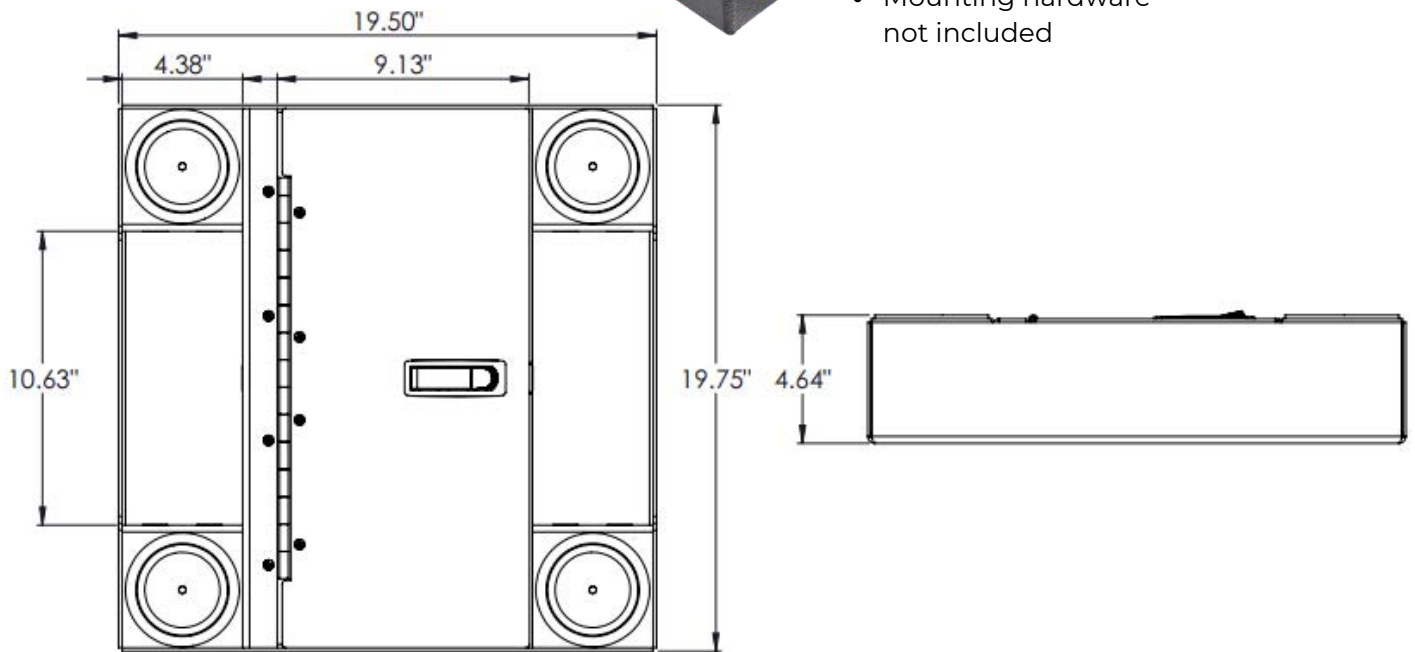

Features:

- 4 cup holders (3.25 in. ID)
- Latching storage compartment

Type	Part #	Dimensions	Weight	Compartment Size	Colors
Multipurpose 4 Cup Holder	FMI-52020	19.5 W x 19.75 D x 4.64 H in.	16.6 lbs.	9.13 L x 19.75 W in.	Black Raptor Gray Raptor DA Finish



- Mounting hardware not included

Side View

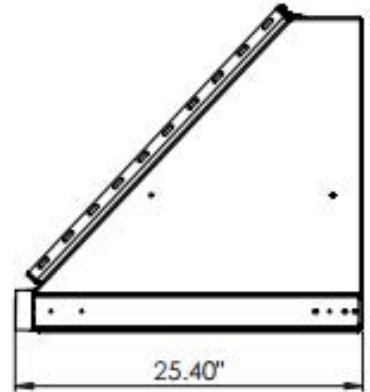

Top View

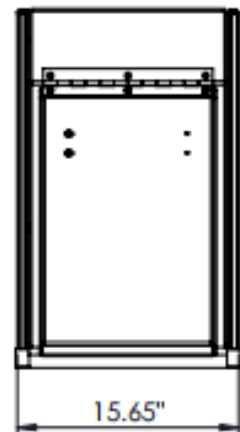

Front View

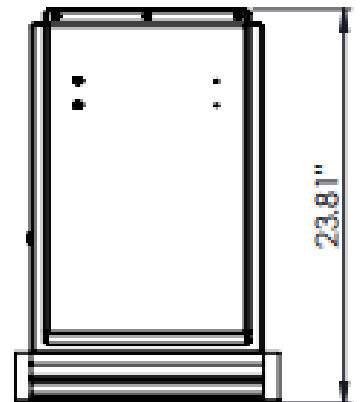

Features:

- FMI custom strap secures saw
- Tray flips up for easy access to saw
- Additional storage underneath the tray

Type	Part #	Dimensions	Weight	Material
Flip Up Saw Box, for 26 in. compartments (stores up to 34 in. saw)	FMI-53011	15.65 W x. 25.40 D x 23.81 H in.	52.8 lbs.	3/16" Aluminum

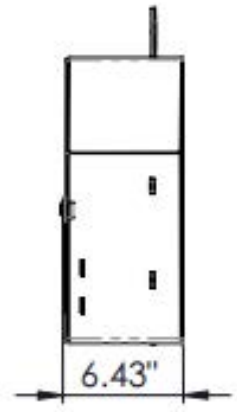
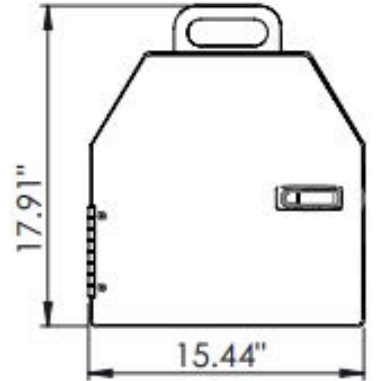

Accommodates up to 15" blade

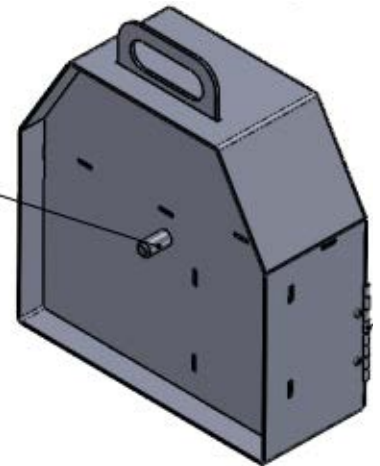

Features:

- Latching door keeps contents secure
- Internal pockets for accessory storage
- Saw blade storage on back post with secure clip

Type	Part #	Dimensions	Weight	Colors
Saw Blade Holder Deluxe With Storage	FMI-53500	15.44 W x 6.43 D x 17.91 H in.	14.2 lbs.	Black Raptor Gray Raptor DA Finish



- Mounting hardware not included

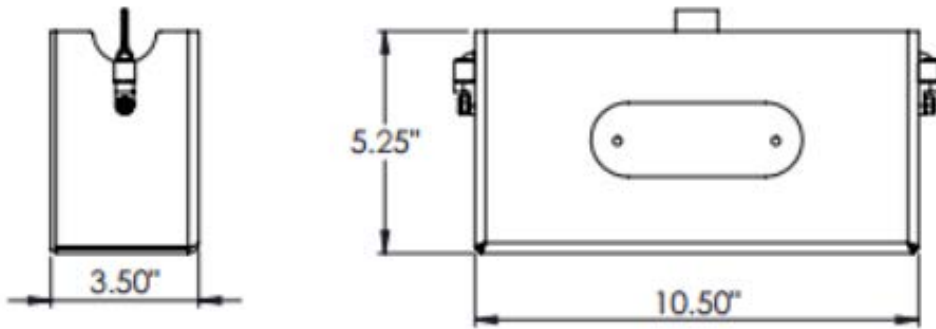

Features:

- Single cell
- Can be mounted vertically or horizontally
- Elastic strap allows for secure storage of most glove boxes

Type	Part #	Dimensions	Weight	Colors
1 Cell Glove Box	FMI-51500	10.5 W x 5.25 D x 3.5 H in.	2.0 lbs.	Black Raptor Gray Raptor DA Finish

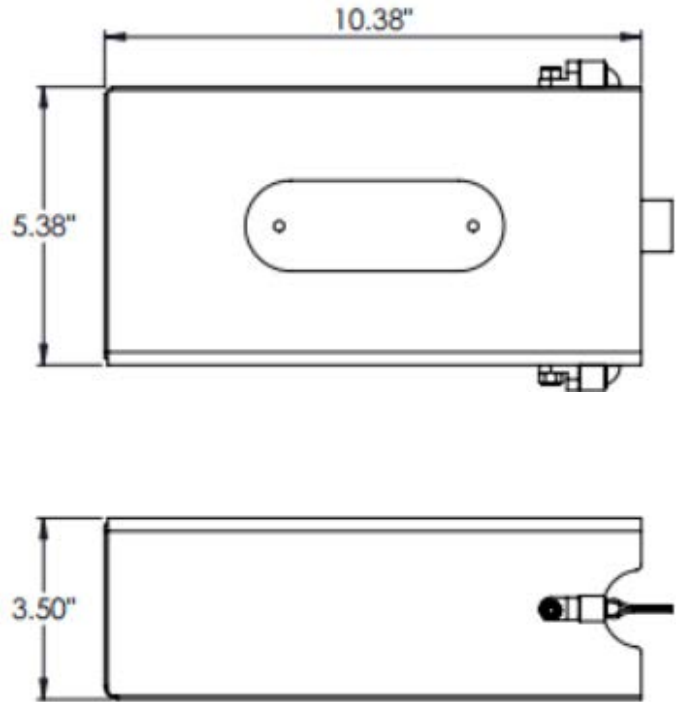

- Mounting hardware not included

Features:

- Single cell
- Can be mounted vertically or horizontally
- Elastic strap allows for secure storage of most glove boxes

Type	Part #	Dimensions	Weight	Colors
1 Cell Glove Box Side Loaded	FMI-51501	5.38 W x 10.38 D x 3.5 H in.	2.2 lbs.	Black Raptor Gray Raptor DA Finish



- Mounting hardware not included

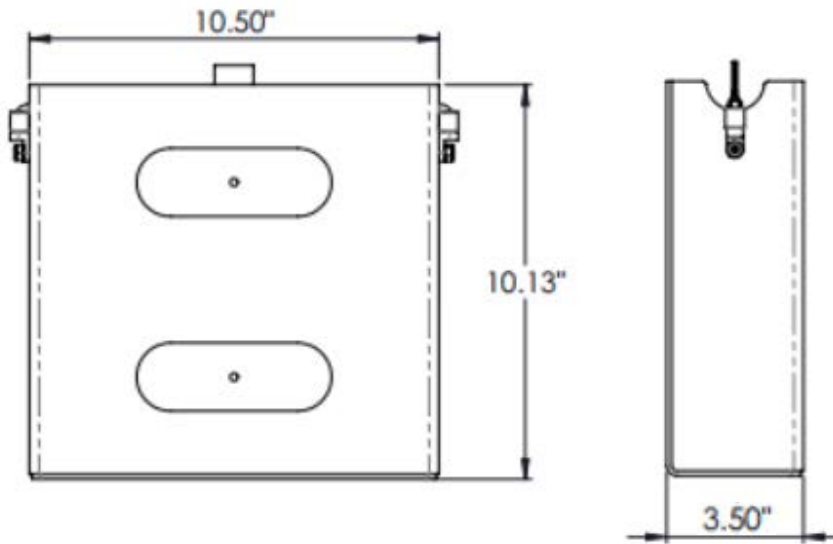

Features:

- Can be mounted vertically or horizontally
- Elastic strap allows for secure storage of most glove boxes

Type	Part #	Dimensions	Weight	Colors
2 Cell Glove Box	FMI-51505	10.5 W x 10.13 D x 3.5 H in.	3.6 lbs	Black Raptor Gray Raptor DA Finish



- Mounting hardware not included

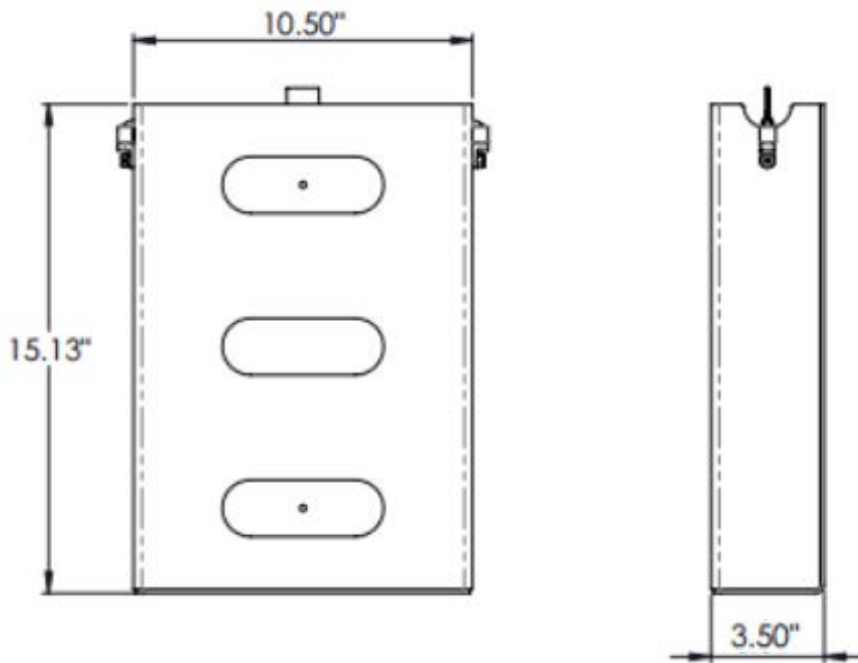

Features:

- Can be mounted vertically or horizontally
- Elastic strap allows for secure storage of most glove boxes

Type	Part #	Dimensions	Weight	Colors
3 Cell Glove Box	FMI-51510	10.5 W x 15.13 D x 3.5 H in.	5.4 lbs.	Black Raptor Gray Raptor DA Finish



- Mounting hardware not included

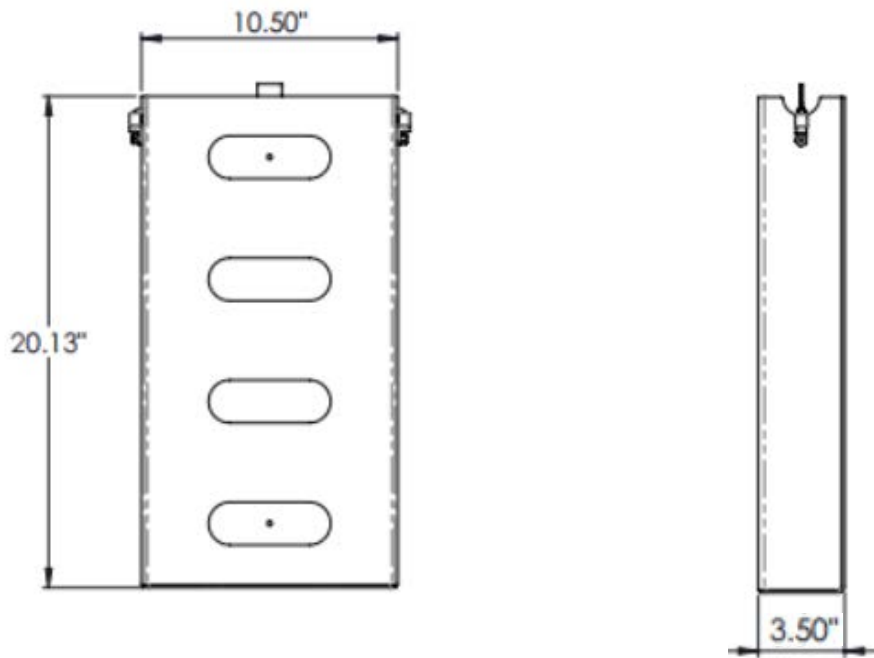

Features:

- Can be mounted vertically or horizontally
- Elastic strap allows for secure storage of most glove boxes

Type	Part #	Dimensions	Weight	Colors
4 Cell Glove Box	FMI-51515	10.5 W x 20.13 D x 3.5 H in.	6.6 lbs.	Black Raptor Gray Raptor DA Finish

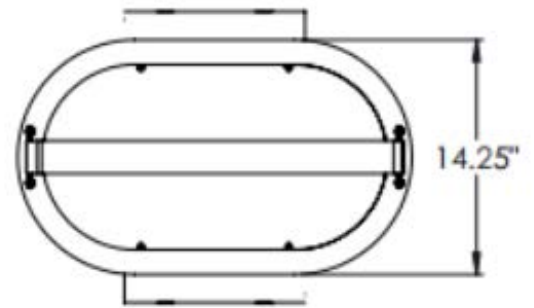
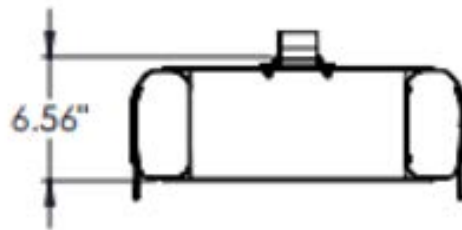
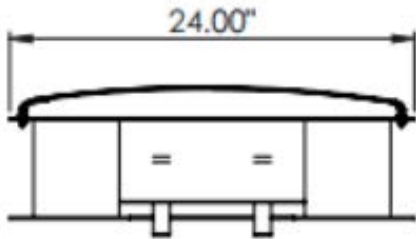

Features:

- Strap kit included
- Straps keep hoses organized
- Foam insert can be cut to fit most controllers

Type	Part #	Dimensions	Weight	Material
Air Bag Controller Tote (Tread Plate)	FMI-50047	6.56 W x 24.0 D x 14.25 H in.	9.6 lbs	Tread Plate

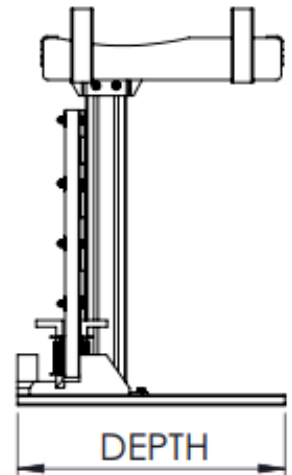
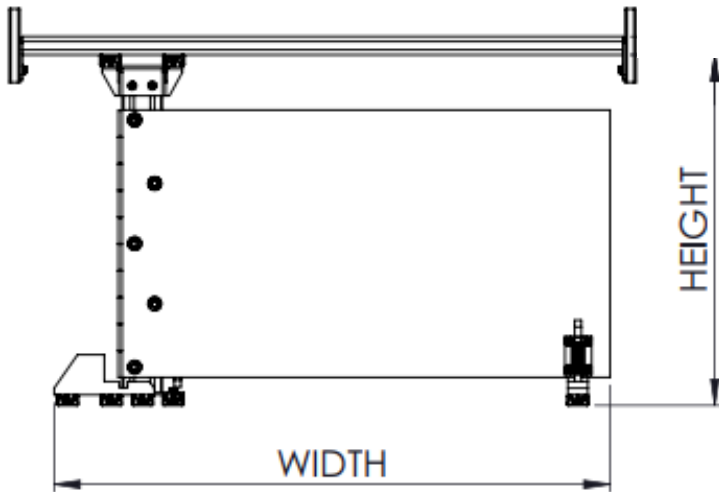
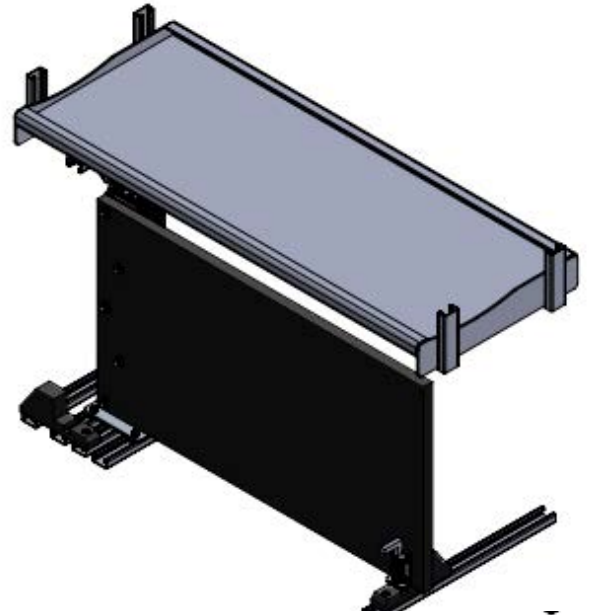
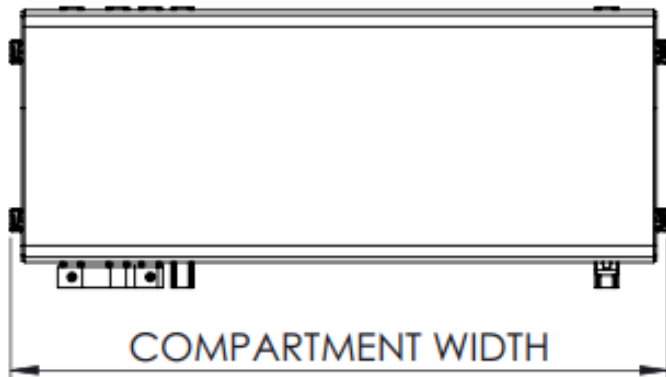

Features:

- Latch system keeps boards secure whether open or shut
- Polycarbonate board allows for easy and secure tool mounting.

Type	Part #	Ordering
Swingout Tool Board	FMI-20000	Contact for custom quote!

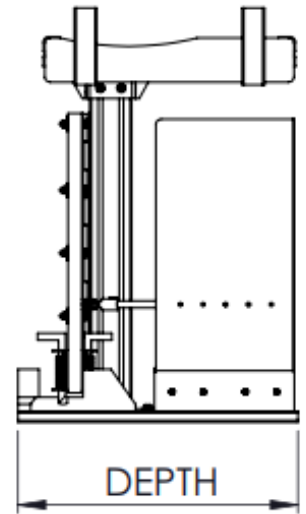
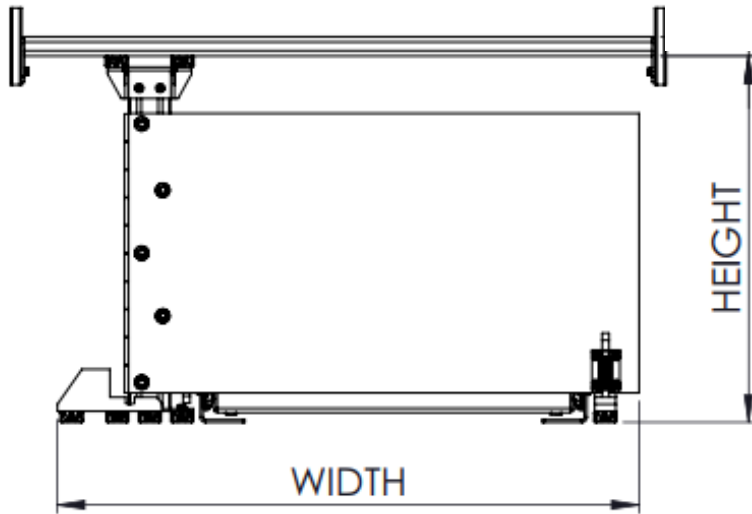
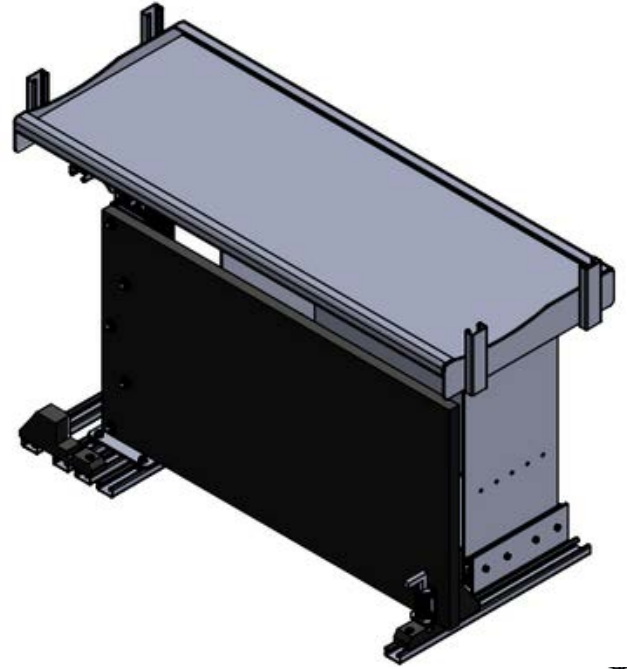
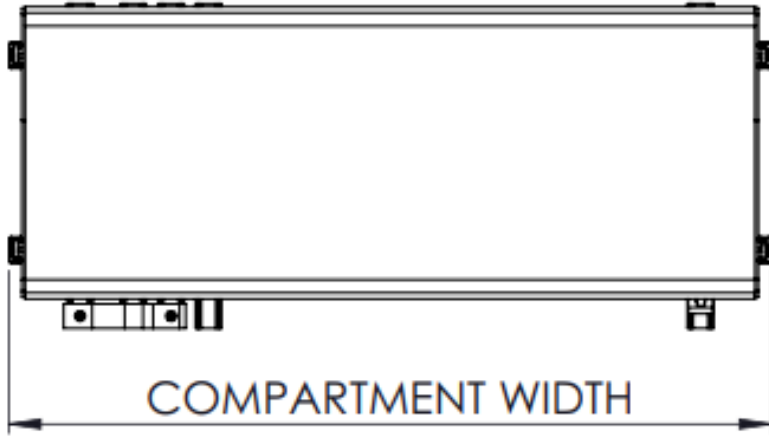

Features:

- Latch system keeps boards secure whether open or shut
- Polycarbonate board allows for easy and secure tool mounting.
- Pull out back wall comes forward when the board is open for easy tool retrieval.

Type	Part #	Ordering
Swingout Tool Board with Pullout Back Wall	FMI-20001	Contact for custom quote!

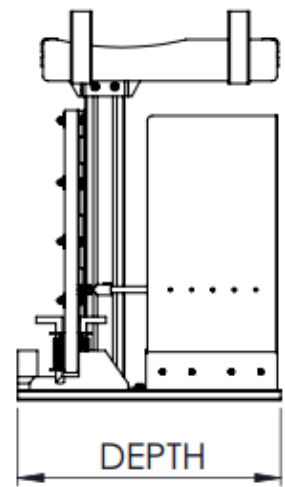
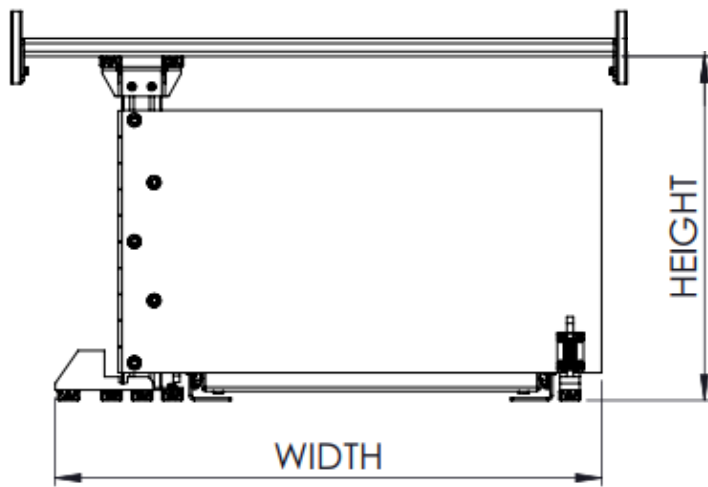
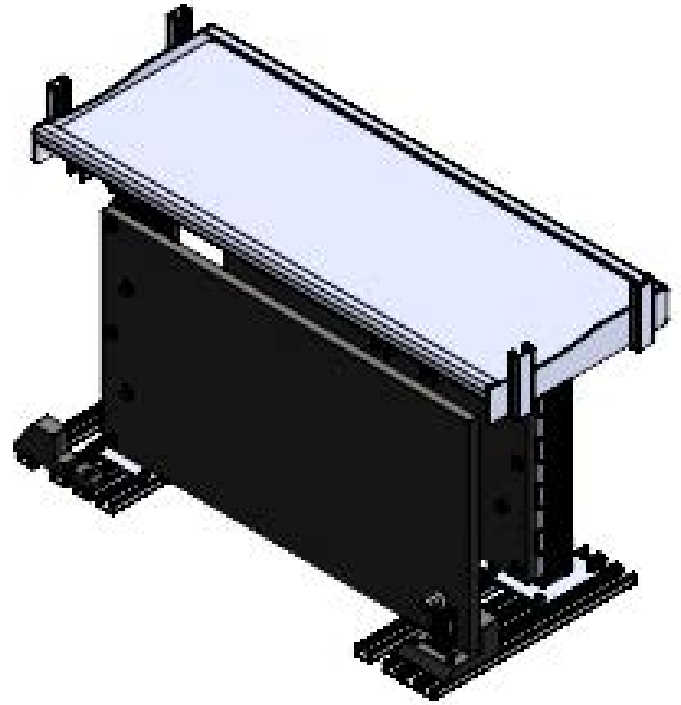
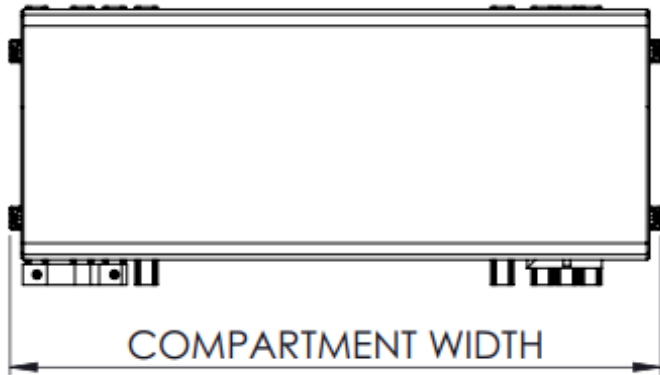

Features:

- Latch system keeps boards secure whether open or shut
- Two polycarbonate boards allow for easy and secure tool mounting.

Type	Part #	Ordering
Double Swingout Tool Board	FMI-20002	Contact for custom quote!



Double Swingout Tool Board With Pull Out Back Wall

Tool Boards

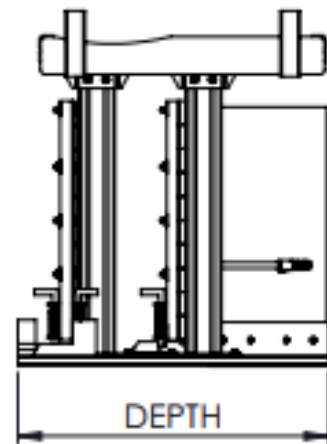
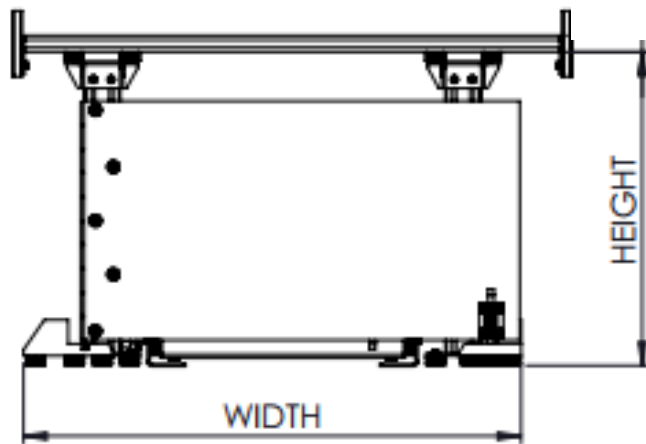
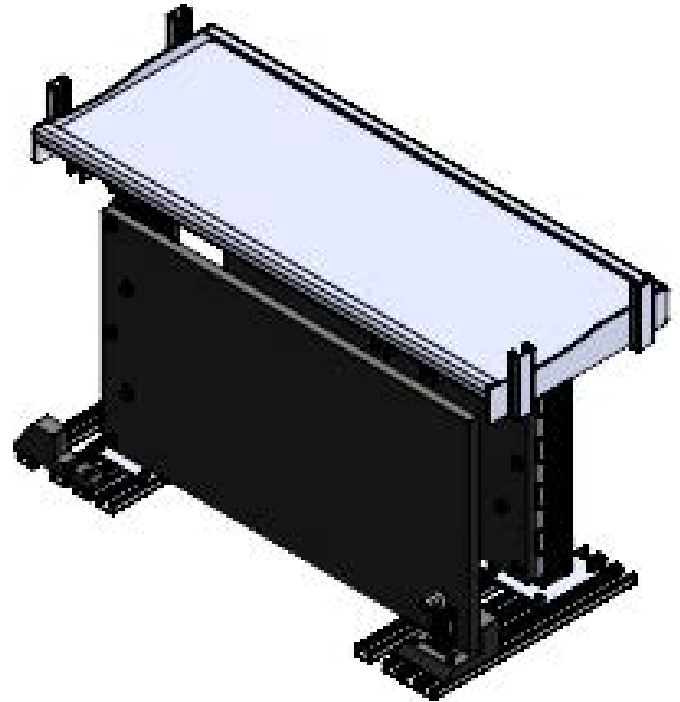
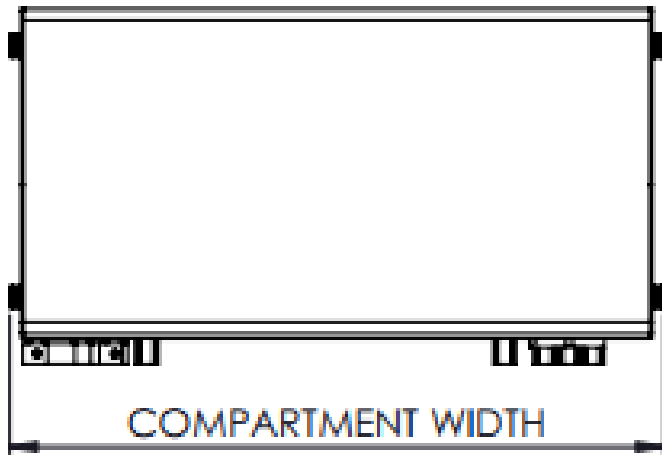

Features:

- Latch system keeps boards secure whether open or shut
- Two polycarbonate boards allow for easy and secure tool mounting
- Pull out back wall comes forward when the board is open for easy tool retrieval

Type	Part #	Ordering
Double Swingout Tool Board	FMI-20003	Contact for custom quote!



Adjustable Shelf

Shelving

Required to mount: Shelf Mounted Hopper

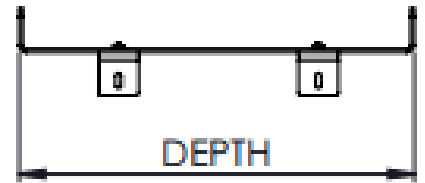
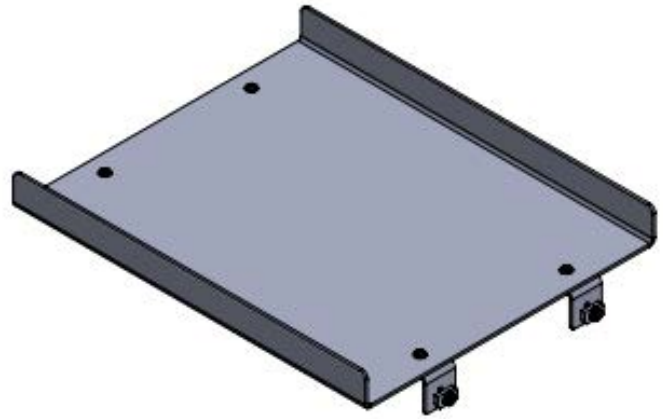
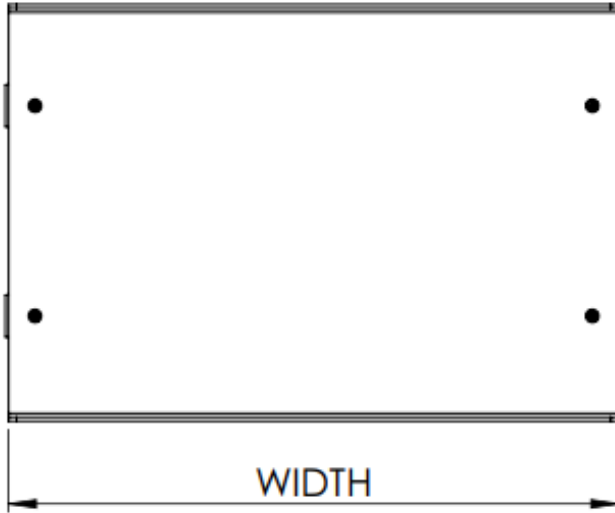

Type	Part #	Material	Ordering
Adjustable Shelf Kit	FMI-41001-XXXX	3/16" Aluminum	Contact for custom quote!



Double Lip Shelf

Shelving

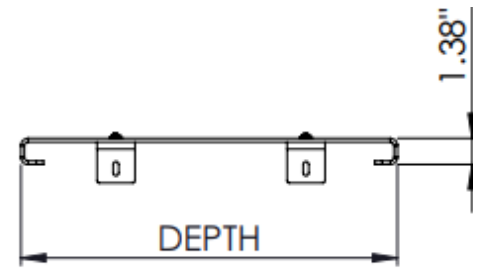
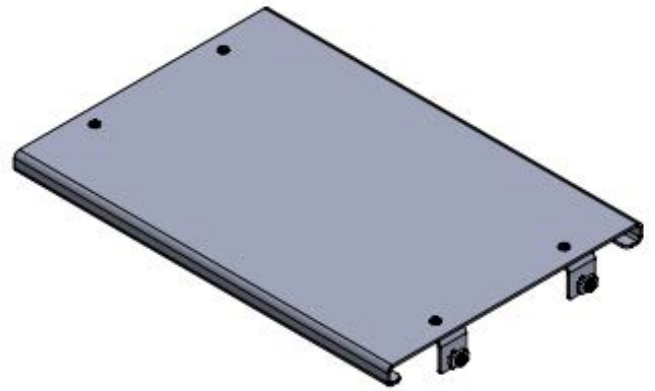
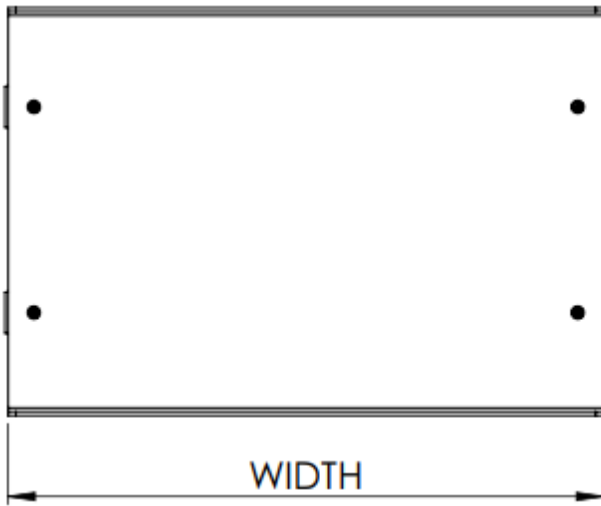

Type	Part #	Material	Ordering
Double Lip Shelf L1/R1	FMI-42001-XXXX	3/16" Aluminum	Contact for custom quote!

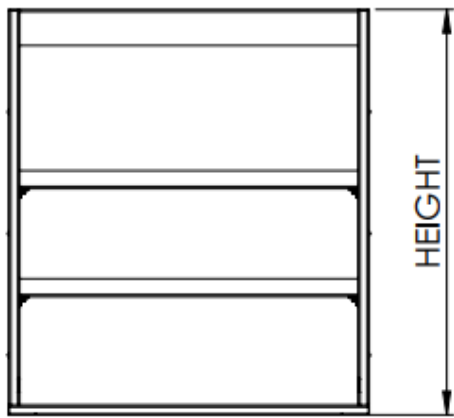
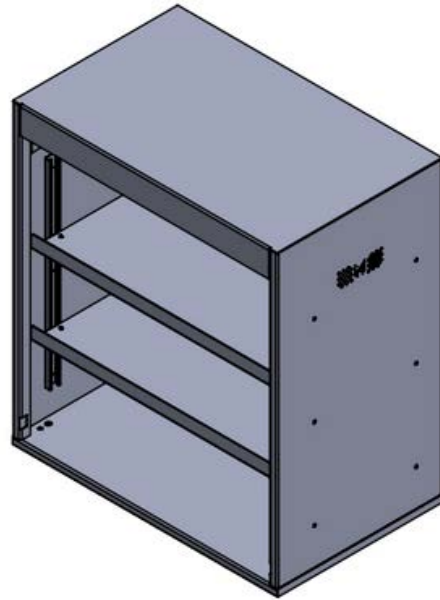
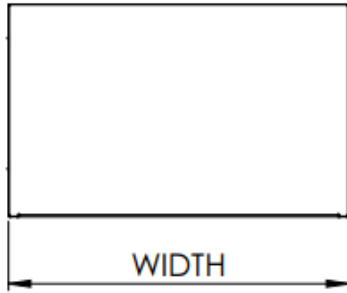

- Mounting hardware not included

Features:

- 2 Adjustable Shelves
- Luma Bar Light included with AMDOR Roll Up Door
- Custom Sizing (17" W x 15" D x 22" H Requires: Adjustable Shelf Kit (FMI-41001)

Type	Part #	Options	Paint	Ordering
EMS Cabinet	FMI-65XXX	Custom Sizing Netting or Roll Up Door	Black Raptor Gray Raptor Black Multispec Gray Multispec	Contact for custom quote!



[View Example Here](#)

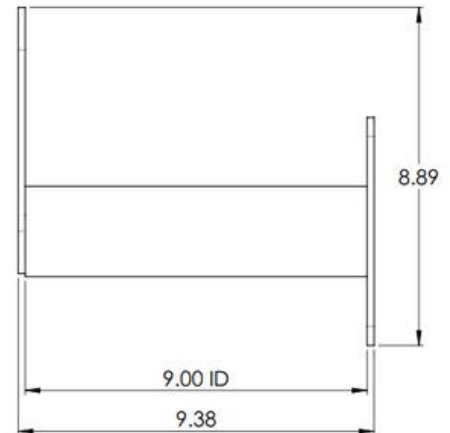
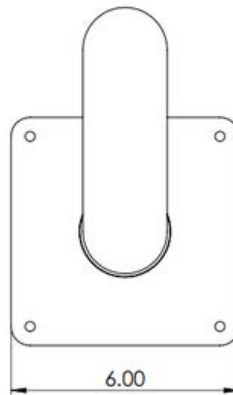
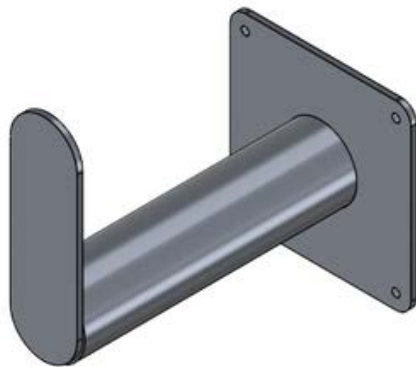
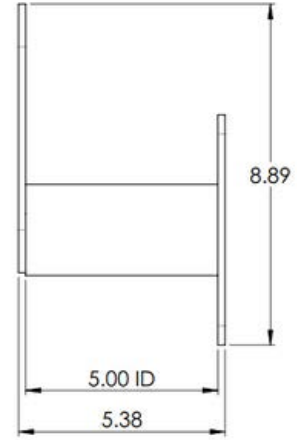
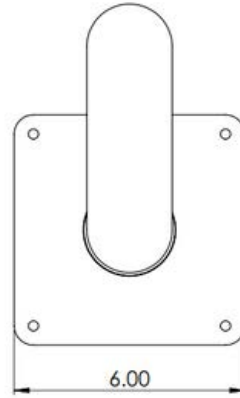
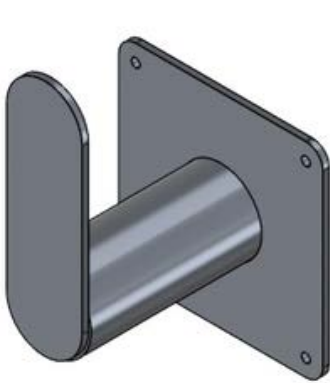

Features:

- 5-inch and 9-inch versions are available
- Allows high rise pack mounting to any vertical surface.

Type	Part #	Dimensions	Weight	Material
HIGH RISE PACK HOLDER, 5" ID	FMI-50069	6.00 W x 5.38 D x 8.89 H in.	1.3 lbs.	3/16" Aluminum
HIGH RISE PACK HOLDER, 9" ID	FMI-50070	6.00 W x 9.38 D x 8.89 H in.	2.0 lbs.	3/16" Aluminum



M18 Chainsaw Bracket

Brackets

[View Example Here](#)

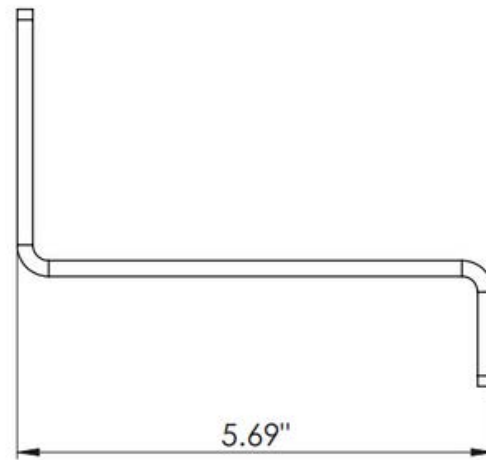
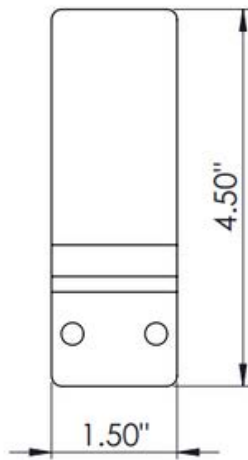

• Mounting hardware not included

Features:

- Adjustable strap keeps saw secure
- Allows saw to be secured vertically or horizontally
- Polycarbonate blocks keep chainsaw from moving while in transit

Type	Part #	Dimensions	Weight	Material
BRACKET KIT, CHAINSAW, M18	FMI-31031	1.50 W x 5.89 D 4.50 H in. Bracket. 1.00 W x 5.00 in. Poly Blocks	~ 1.0 lbs.	3/16" Aluminum



9" Cutoff Saw Bracket

Brackets

[View Example Here](#)

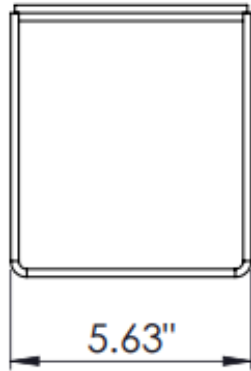

- Mounting hardware not included

Features:

- Adjustable strap keeps saw secure
- Can mount saw at a variety of angles

Type	Part #	Dimensions	Weight	Material
BRACKET KIT, MILWAUKEE 9" CUT-OFF SAW, M18	FMI-31032	5.63 W x 6.38 D x 6.69 H in.	~ 3.3 lbs.	3/16" Aluminum



Milwaukee Tower Light Bracket

Brackets

[View Example Here](#)

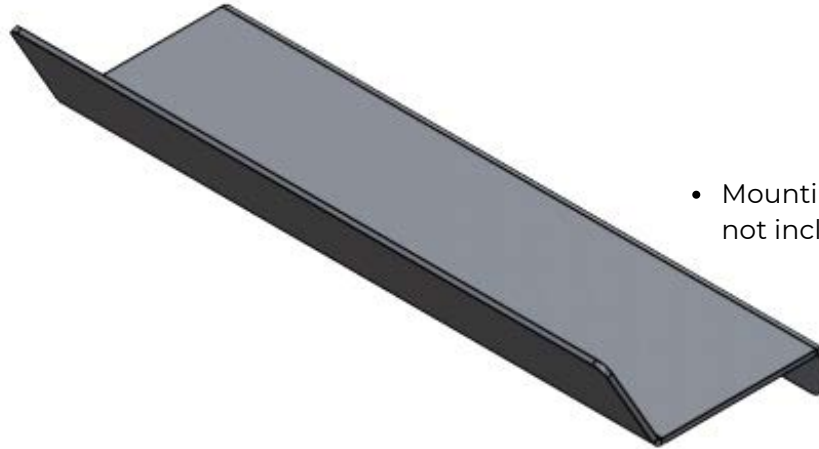

- Mounting hardware not included

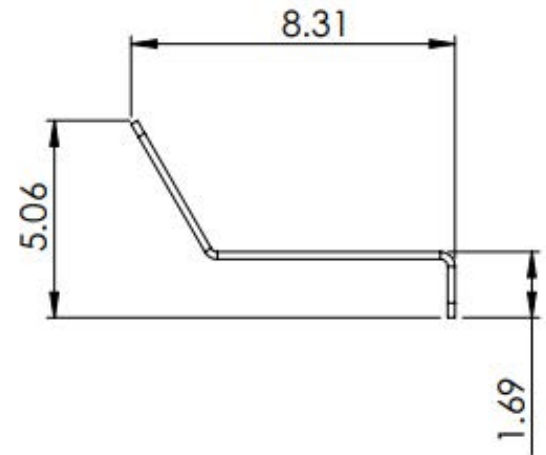
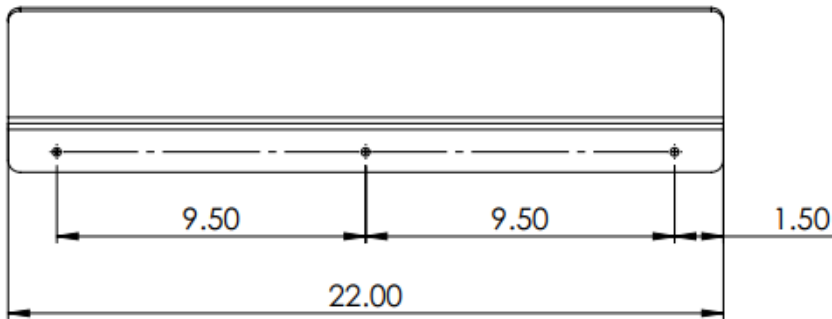

Features:

- Adjustable strap keeps light secure.

Type	Part #	Dimensions	Weight	Material
BRACKET, HORIZONTAL, MILWAUKEE TOWER LIGHT	FMI-32013	22.00 W x 8.31 D x 5.06 H in.	4.4 lbs.	3/16" Aluminum



[View Example Here](#)

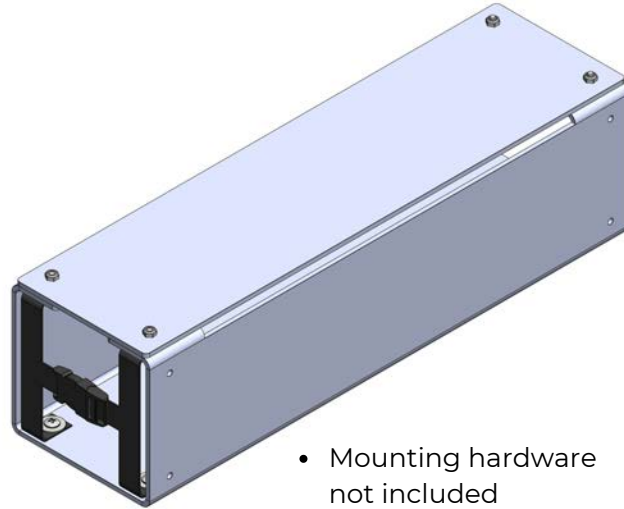

- Mounting hardware not included

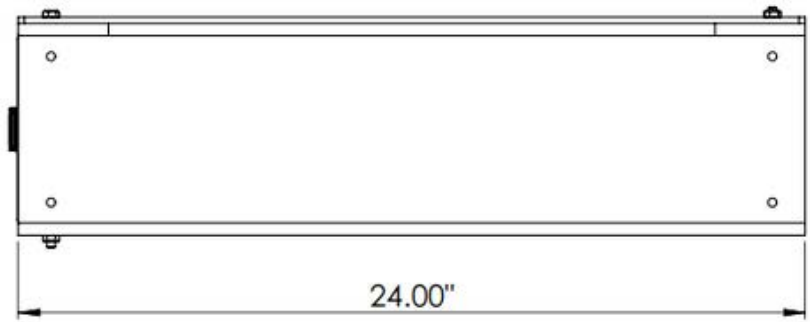
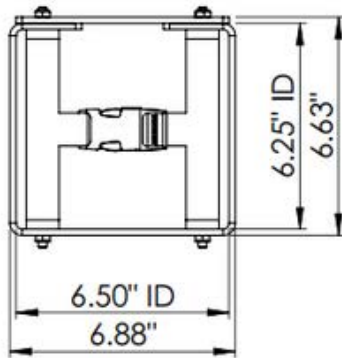

Features:

- Adjustable strap keeps air bottle secure up to 6.25 in. in diameter.

Type	Part #	Dimensions	Weight	Material
AIR BOTTLE STORAGE(MODULAR), SINGLE UNIT,	FMI-50928	6.88 W x 24.00 D x 6.63 H in.	11lb	3/16" Aluminum

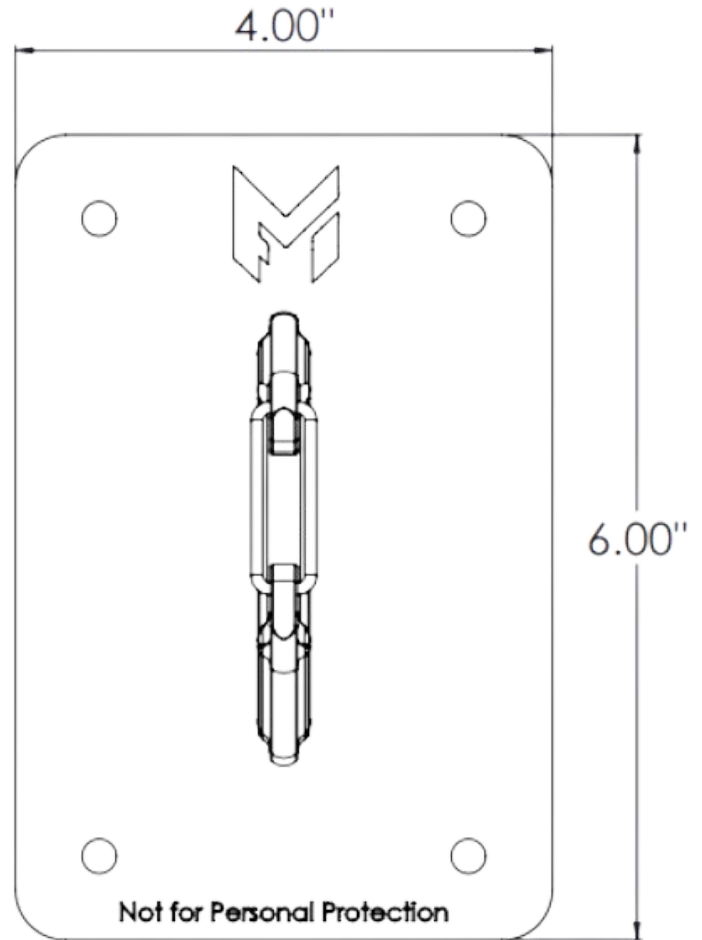

- Mounting hardware not included

Features:

- 3/16" aluminum frame is incredibly durable
- Note: Not for personal protection

Type	Part #	Dimensions	Weight	Hook Color	Material
FMI Helmet Hook	FMI-50054	4.0 W x. 6.0 D in.	0.4 lbs.	Orange	3/16" Aluminum



Contact Us:



(937) 323-2770



Orders@fmico.com



www.fmico.com



5325 Prosperity Dr. Springfield OH 45502

AMD-R

luma-bar



Actual

M-FMI

