



SL-16[®]

Technical/Installation Information

IMPORTANT NOTICE

READ THIS MANUAL COMPLETELY PRIOR TO BEGINNING THE INSTALLATION OF ANY SL SERIES ROOFING SYSTEM.

ALWAYS INSPECT EACH AND EVERY PANEL AND ALL ACCESSORIES BEFORE INSTALLATION. NEVER INSTALL ANY PRODUCT IF ITS QUALITY IS IN QUESTION. NOTIFY ABC IMMEDIATELY IF ANY PRODUCT IS BELIEVED TO BE OUT OF TOLERANCE, SPECIFICATION OR HAS BEEN DAMAGED DURING SHIPMENT.

IF THERE IS A CONFLICT BETWEEN PROJECT ERECTION DRAWINGS PROVIDED OR APPROVED BY THE MANUFACTURER AND DETAILS IN THIS MANUAL, PROJECT ERECTION DRAWINGS WILL TAKE PRECEDENCE.

Ice Dam Disclaimer

ABC designs its standing seam roofs to meet the load requirements dictated by governing codes and project specifications, including applicable snow loads. However, ABC expressly disclaims responsibility for weathertightness or roof point loading issues or other hazards resulting from ice dam situations. Any time ice and snow can melt on the main body of the roof and refreeze at the eave or in the shadow of an adjacent wall, an ice dam situation may develop. In addition to local climate, ice dam formation is affected by many other factors, including but not limited to, roof insulation R value, roof panel color, interior temperature of building, heater location in building, eave overhangs, parapet walls, shading of building roof areas from adjacent trees, parapets, buildings, etc. These factors are design and maintenance issues and are outside the control of ABC. ABC specifically disclaims any liability for damage due to ice dam formation, although the following issues should be taken into consideration concerning standing seam roofs installed in freezing climates:

- Always use field seamed panels. These machine-folded seams are more durable when subjected to occasional icing.
- Eliminate "cold" eave overhangs and parapet walls from the building design. Roof overhangs outside the heated envelope of the building will tend to be colder than the roof areas over the heated envelope. Simple roof designs are preferred. Parapet walls at the eave allow ice and snow to collect due to shading effects and the lower roof temperatures caused thereby.
- Make sure the interior of the building is adequately insulated and the heating is properly distributed. Inadequate insulation in the roof and/or improper heat distribution causes heat flow through the main body of the roof. On days when the temperature is below freezing, this heat gain can cause ice and snow to melt and refreeze at the eave where the roof is colder.
- Lay out the building to prevent the eaves and other roof areas from being shaded during the winter. This may mean eliminating adjacent trees or reconsidering roof geometries.
- Consider using self-regulating heating cables at the eaves to mitigate the effects of ice dams.
- On building designs using attics, over-insulate the attic floor and provide adequate ventilation in the attic. This will reduce heat transfer through the roof resulting in more consistent roof temperatures between eave and field of roof.
- Increase the degree of diligence with respect to underlayment materials at roof areas prone to icing. This may include valleys, eaves, dormers and roof areas near dormers, parapets and the like where shading may occur.

For more information on this subject, please refer to the MCA's Metal Roof Design For Cold Climates manual.

The Engineering data contained herein is for the expressed use of customers and design professionals. Along with this data, it is recommended that the design professional have a copy of the most current version of the North American Specification for the Design of Cold-Formed Steel Structural Members published by the American Iron and Steel Institute to facilitate design. This Specification contains the design criteria for cold-formed steel components. Along with the Specification, the designer should reference the most current building code applicable to the project jobsite in order to determine environmental loads. If further information or guidance regarding cold-formed design practices is desired, please contact the manufacturer.

©Copyright NCI Group, Inc. 2018 All Rights Reserved.

Descriptions and specifications contained herein were in effect at the time this publication was approved for printing. In a continuing effort to refine and improve products, ABC reserves the right to discontinue products at any time or change specifications and/or designs without incurring obligation. **To ensure you have the latest information available, please inquire or visit our website at www.abcmetal.com.** Application details are for illustration purposes only and may not be appropriate for all environmental conditions, building designs or panel profiles. Projects should be designed to conform to applicable building codes, regulations and accepted industry practices. If there is a conflict between this manual and project erection drawings, the erection drawings will take precedence.

TABLE OF CONTENTS

PRODUCT INFORMATION

Design Information	S-4
Application, Storage and Handling Information	S-5 – 6
16" Wide Square Foot Chart	S-7
Freight and Packaging Costs	S-8
Load Tables	S-9
SL 16® UL® Technical Data	S-10
Product Checklist	S-11 - S-20
How To Order Special Trim	S-21

DETAILS

Panel Engagement	S-22
------------------------	------

EXPOSED FASTENER DETAILS

Ridge	S-23
Hip	S-24
Peak Trim	S-25
Eave	S-26
Gutter	S-27
Rake	S-28
Valley	S-29
Side Wall	S-30
End Wall	S-31

CONCEALED FASTENER DETAILS

Ridge/Hip	S-32
Hip	S-33
Peak Trim	S-34
Field Hemming Panel End	S-35
Valley with Offset Cleat	S-36
Eave with Offset Cleat	S-37
Eave Trim with Drip Edge	S-38
Rake	S-39
Side Wall	S-40
End Wall	S-41
Roof Transition	S-42

OTHER DETAILS

Slope Change - Fixed Eave	S-43
Slope Change - Floating Eave	S-44
Profile Vent	S-45
Terms and Conditions of Sale	S-46

PRODUCT INFORMATION

DESIGN INFORMATION

PLANNING

Consult a qualified engineer or architect to be sure that your particular application of this product conforms to applicable building codes, regulations, environmental conditions and accepted industry practices. All suggested applications for SL 16® assume a qualified engineer or architect has been consulted prior to the application of the product. Please note that the details shown may not be appropriate for all environmental conditions and building applications. Prior to ordering panels, all dimensions should be confirmed by field measurements by the customer or installer.

APPLICATIONS

SL 16® is a non-structural, water shedding concealed fastener panel system that can be applied on a variety of projects. They include roofing, siding, mansard, or fascia systems. SL 16® contemporary design, with economical interlocking ribs and fastening flanges make it ideally suitable for new construction or retro-fit markets on both light commercial and residential projects. For panels longer than 36' please inquire. Panels may not be endlapped.

ROOF SUBSTRATE

For roofing applications, apply SL 16® over a properly aligned, smooth continuous structural substrate such as 5/8" or thicker plywood surface with a suitable moisture barrier.

WATER/VAPOR CONTROL (MOISTURE BARRIER UNDERLAYMENT)

When warm moist air contacts a cold surface such as the underside of a metal roof panel, the water vapor contained in it condenses. The continuous presence of moisture is detrimental to many things, including metal. The use of suitable moisture/vapor barrier and insulations protect the metal and your investment. The minimum acceptable barrier would be 30# builders felt. Other breathable barriers such as "Shingle Mate®" or "StormGuard® HT" from GAF Materials Corporation provide exceptional long term protections when applied as directed by the manufacturer. Whatever barrier you decide to use must be applied in a smooth continuous manner, free from holes or rips. Fasteners used to attach the barrier must be covered to protect the underside of the panels. Fasteners must be flush with the surface of the barrier or they will cause unwanted distortion of the panel surface. It is further recommended that peak and eave or gable vents be installed to provide adequate air flow in trapped air spaces such as attics. Consult a qualified design professional for venting requirements.

OIL CANNING

Flat surface areas in metal panels are subject to visible stress. This "oil canning" (wave) is evident to some degree in all flat metal surfaces. Every effort is taken to minimize this condition during the forming process. Oil canning does not affect the structural integrity of the panel and is not a cause for rejection. For information on this subject, please refer to MCA's oil canning technical bulletin.

FASTENERS

SL 16® panels are best secured to a solid wood substrate by using a 10 x 1" Type A pancake head fastener. Fastener spacing is dependent upon design considerations. A qualified engineer must be consulted to insure that all design codes and other pertinent criteria are met. Refer to load tables on pages S-9. Refer to page S12 for additional fastener information. Do not overdrive fasteners. This can cause panel distortion.

Product Selection Chart

Gauge	Galvalume Plus	Signature 200
26-Gauge	●	●
29-Gauge	●	●

● available in any quantity (see 26/29 gauge color chart for available colors)

PRODUCT INFORMATION

APPLICATION, STORAGE AND HANDLING INFORMATION

SAFETY PRECAUTIONS

Improper unloading and handling of bundles and crates may cause bodily injury or material damage. Use extreme care in the operation of power lifting devices such as cranes and forklifts and follow the safety instructions provided by their manufacturer. Crates, boxes and bundles may be bulky, heavy, or both. The improper or unaided lifting of them may cause bodily injury. The manufacturer is not responsible for bodily injuries or material damage due to improper handling during unloading, storage, or job site placement.

Protective heavy duty gloves should be worn when handling metal panels and trim products. Safety goggles or face shield should be worn while cutting or drilling metal products with power tools. Follow the safety instructions provided by the manufacturer of the power tools.

Use extreme care when walking, sitting, standing, or kneeling on a metal roof to avoid a fall. Galvalume® and galvanized panels have a light coating of oil to protect the panels from moisture prior to erection. They can be extremely slippery, as are painted panels, when they are wet. If necessary, remove the oil coating with a non-abrasive detergent and water mixture followed by a clear water rinse. Insure the panels are dry prior to installation.

STORAGE AND HANDLING

To preserve and protect the attractive appearance of American Building Components' roofing and siding from damage caused by moisture, corrosive chemicals or improper handling, it is necessary that you take a few simple precautions. When material is received bundled, panels should be inspected for moisture. If there is moisture, the panels should be separated and dried. If shipping damage is found, the carrier should be advised and a notation made on the bill of lading.

On job sites, reasonable care should be taken when handling painted surfaces during installation in order to protect the finish. Although the paint coating is tough and provides impact resistance, dragging panels across the surface of one another will almost certainly mar the finish.

Prolonged storage of sheets in bundles is not recommended. If conditions do not permit immediate erection, extra care must be taken to protect the material from damage caused by moisture.

Store bundled sheets **ONLY IN A DRY PLACE**. Sheets should be unbundled, stood on end against an interior wall to allow for air circulation. If unable to store sheets in an upright position, strapping bands should be broken and sheets should be blocked off the floor with one end slightly elevated. Stacked sheets should then be completely protected from the elements while maintaining good airflow to prevent condensation. A properly draped canvas tarpaulin, that allows air flow, is an example of a good protective cover. Do not use plastic as it causes sweating or condensation to occur.

BUILDING DESIGN AND CONSTRUCTION

It is important to protect metal panels from potentially corrosive situations and materials. This will insure the good performance and long life of the metal. If installing metal panels over green lumber, damp lumber, or treated lumber (CCA or ACQ), a barrier must be installed to separate the wood from the metal. A barrier may be formed with plastic or other suitable material. Avoid contact with, or water runoff from, dissimilar metals such as copper, lead or graphite. Dissimilar metals under the roof panels may be separated with asphalt, builders felt, caulking compounds or gasket material.

Metal panels must further be protected from contact with strong chemicals such as fertilizers, lime acids, animal waste and soil. All of these have the potential to initiate corrosion in metal panels. Metal panels should not be in permanent contact with soil.

Temperature variations, (dew point) between the outside air and the interior building air mass can cause condensation to occur on the inside of the building on the panel's surfaces. Proper venting and air flow consideration and the use of a vapor barrier such as vinyl backed insulation can eliminate this problem. If left unattended, condensation can cause the premature degradation of the metal and void any applicable warranties. For information on this subject, please refer to MCA's white paper on controlling condensation in steep slope metal roofing systems.

The substructure, on which the panels are to be installed, must be "on plane" (1/4" tolerance) from eave to ridge. Maximum recommended panel length is 36'; minimum panel length is 3'.

VENTILATION

Sufficient air movement should be provided by means of a ridge or rotary vent, power operated fans, or other openings to minimize condensation. Contact the equipment manufacturer for specific information or a qualified mechanical engineer.

PRODUCT INFORMATION

APPLICATION, STORAGE AND HANDLING INFORMATION (cont'd)

ROOFING INSTALLATION

Check substructure for proper alignment and uniformity to avoid panel distortion. ABC recommends the use of 5/8" plywood for the substructure. Minimum 5/8" plywood substructure is MANDATORY for UL 90 Uplift Rating.

THE MINIMUM roof slope recommended is 3 inches of rise per foot. This ensures that sufficient slope is present for adequate drainage. The panels must be installed over a completely water-proofed substructure.

It is important to remember that in the installation of roof sheets, the sidelaps should face away from the direction of the prevailing wind. The first sheet should be installed square with the eave and at the down-wind end of the roof, farthest from the direction of the wind.

For proper fastener application, refer to our published guide.

Remember to sweep the roof clean of any metal filings created from fastener placement or cutting of panels to prevent rust marks on the surface of the painted panels.

Installing SL 16® panels over an uneven substrate will cause distortion of the panel. It is the responsibility of the installer to insure a suitable substrate prior to panel application. Distortion in the panel caused by an uneven substrate, ripples or laps in the vapor barrier, debris, etc., are not defects in the material, and are not the responsibility of ABC. SL 16® panels cannot be endlapped.

CLOSURES AND SEALANTS

To thoroughly protect the contents of any structure from moisture, regardless of building size or roof slope, closure strips should be used at the roof ridge, hip and eave.

For maximum protection, all caulking used should be urethane. **Silicone caulks are not recommended for panels or trims.**

CUTTING METAL PANELS

ABC recommends the use of power shears or nibblers that can follow the contour of the panel's profile. While not recommended, if a power saw is to be used, you must use a blade designed to cut the metal at a low temperature to prevent melting of the Galvalume® coating, such as the Slasher® from Dynamic Fastener. You should protect the panel during the cutting process to prevent marring the panel surface. Panels should be thoroughly brushed after cutting to remove any particles of metal and caution should be taken that filings from cutting don't settle on other panels. Follow the safety instructions provided by the manufacturer when using any tools.

PANEL SELECTION

ABC's bare Galvalume® (Galvalume Plus®), and color coated products are produced from material that meets or exceeds the specifications outlined in ASTM-792.

If you chose a bare Galvalume® (Galvalume Plus®), for your application you should be aware that this product is recommended for applications where aesthetic appearance is not your prime concern. Unpainted products may not weather uniformly and while they may be shiny and bright when new, they will fade or "patina" with age. Acid rain and other corrosive atmospheres, as well as the accumulation of airborne debris and dirt will affect this aging process and the products' appearance.

If aesthetic appearance is one of your concerns, ABC recommends you select one of our many color coated panel selections. Copies of ABC's color coated panel warranty are available at your point of purchase, or from the ABC office located nearest to you.

Failure to comply with these precautions relieves the manufacturer of responsibility for any resultant damage to, or deterioration of the product and voids any applicable warranties. Contact your local ABC facility for copies of our Limited Color Coated and Galvalume® warranties. Except as outlined in our published limited warranties, ABC makes no warranty, express or implied, limited or otherwise, as to the merchantability or fitness for any particular purpose, with respect to the product sold.

PRODUCT INFORMATION

SQUARE FOOT CHART

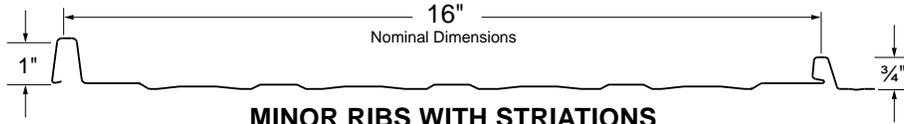

Number of Square Feet Per Panel

	0"	1"	2"	3"	4"	5"	6"	7"	8"	9"	10"	11"
1 FT.	1.33	1.44	1.56	1.67	1.78	1.89	2.00	2.11	2.22	2.33	2.44	2.56
2 FT.	2.67	2.78	2.89	3.00	3.11	3.22	3.33	3.44	3.56	3.67	3.78	3.89
3 FT.	4.00	4.11	4.22	4.33	4.44	4.58	4.67	4.78	4.89	5.00	5.11	5.22
4 FT.	5.33	5.44	5.56	5.67	5.78	5.89	6.00	6.11	6.22	6.33	6.44	6.56
5 FT.	6.67	6.78	6.89	7.00	7.11	7.22	7.33	7.44	7.56	7.67	7.78	7.89
6 FT.	8.00	8.11	8.22	8.33	8.44	8.56	8.67	8.78	8.89	9.00	9.11	9.22
7 FT.	9.33	9.44	9.56	9.67	9.78	9.89	10.00	10.11	10.22	10.33	10.44	10.56
8 FT.	10.67	10.78	10.89	11.00	11.11	11.22	11.33	11.44	11.56	11.67	11.78	11.89
9 FT.	12.00	12.11	12.22	12.33	12.44	12.56	12.67	12.78	12.89	13.00	13.11	13.22
10 FT.	13.33	13.44	13.56	13.67	13.78	13.89	14.00	14.11	14.22	14.33	14.44	14.56
11 FT.	14.67	14.78	14.89	15.00	15.11	15.22	15.33	15.44	15.56	15.67	15.78	15.89
12 FT.	16.00	16.11	16.22	16.33	16.44	16.56	16.67	16.78	16.89	17.00	17.11	17.22
13 FT.	17.33	17.44	17.56	17.67	17.78	17.89	18.00	18.11	18.22	18.33	18.44	18.56
14 FT.	18.67	18.78	18.89	19.00	19.11	19.22	19.33	19.44	19.56	19.67	19.78	19.89
15 FT.	20.00	20.11	20.22	20.33	20.44	20.56	20.67	20.78	20.89	21.00	21.11	21.22
16 FT.	21.33	21.44	21.56	21.67	21.78	21.89	22.00	22.11	22.22	22.33	22.44	22.56
17 FT.	22.67	22.78	22.89	23.00	23.11	23.22	23.33	23.44	23.56	23.67	23.78	23.89
18 FT.	24.00	24.11	24.22	24.33	24.44	24.56	24.67	24.78	24.89	25.00	25.11	25.22
19 FT.	25.33	25.44	25.56	25.67	25.78	25.89	26.00	26.11	26.22	26.33	26.44	26.56
20 FT.	26.67	26.78	26.89	27.00	27.11	27.22	27.33	27.44	27.56	27.67	27.78	27.89
21 FT.	28.00	28.11	28.22	28.33	28.44	28.56	28.67	28.78	28.89	29.00	29.11	29.22
22 FT.	29.33	29.44	29.56	29.67	29.78	29.89	30.00	30.11	30.22	30.33	30.44	30.56
23 FT.	30.67	30.78	30.89	31.00	31.11	31.22	31.33	31.44	31.56	31.67	31.78	31.89
24 FT.	32.00	32.11	32.22	32.33	32.44	32.56	32.67	32.78	32.89	33.00	33.11	33.22
25 FT.	33.33	33.44	33.56	33.67	33.78	33.89	34.00	34.11	34.22	34.33	34.44	34.56
26 FT.	34.67	34.78	34.89	35.00	35.11	35.22	35.33	35.44	35.56	35.67	35.78	35.89
27 FT.	36.00	36.11	36.22	36.33	36.44	36.56	36.67	36.78	36.89	37.00	37.11	37.22
28 FT.	37.33	37.44	37.56	37.67	37.78	37.89	38.00	38.11	38.22	38.33	38.44	38.56
29 FT.	38.67	38.78	38.89	39.00	39.11	39.22	39.33	39.44	39.56	39.67	39.78	39.89
30 FT.	40.00	40.11	40.22	40.33	40.44	40.56	40.67	40.78	40.89	41.00	41.11	41.22
31 FT.	41.33	41.44	41.55	41.67	41.78	41.89	42.00	42.11	42.22	42.33	42.44	42.56
32 FT.	42.67	42.78	42.89	43.00	43.11	43.22	43.33	43.44	43.56	43.67	43.78	43.89
33 FT.	44.00	44.11	44.22	44.33	44.44	44.56	44.67	44.78	44.89	45.00	45.11	45.22
34 FT.	45.33	45.44	45.56	45.67	45.78	45.89	46.00	46.11	46.22	46.33	46.44	46.56
35 FT.	46.67	46.78	46.89	47.00	47.11	47.22	47.33	47.44	47.56	47.67	47.78	47.89
36 FT.	48.00	48.11	48.22	48.33	48.44	48.56	48.67	48.78	48.89	49.00	49.11	49.22
37 FT.	49.33	49.44	49.56	49.67	49.78	49.89	50.00	50.11	50.22	50.33	50.44	50.56
38 FT.	50.67	50.78	50.89	51.00	51.11	51.22	51.33	51.44	51.56	51.67	51.78	51.89
39 FT.	52.00	52.11	52.22	52.33	52.44	52.56	52.67	52.78	52.89	53.00	53.11	53.22
40 FT.	53.33	53.44	53.56	53.67	53.78	53.89	54.00	54.11	54.22	54.33	54.44	54.56

PRODUCT INFORMATION

FREIGHT AND PACKAGING COST

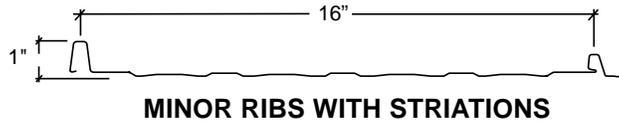

PANEL PRICING

1. All pricing is based on net coverage.
 2. For panel lengths under 4'-0" add \$1.05 per sheet.
 3. Panels are custom cut-to-the-inch.
 4. Panels must be specified as: "Striated" or "Striated with Minor Ribs".
- *Please inquire for other panel types.

PACKAGING COST:

Standard Packaging: Strippable film on panel ribs, wood saddles and trusses as required \$6.00 per square - \$60.00 minimum charge.

DELIVERY:

1. 29 gauge premium colors Approximately 15 working days.
2. Other gauges, colors, and metals Please inquire.

NOTES:

1. For panels—lengths longer than 36'-0" Please inquire.
(generally two lifts must be used for panels over 30'0")
2. Minimum panel length of 3'.
3. Recommended roofing applications are over a solid substrate
(5/8" plywood with a suitable moisture/vapor barrier).
4. Minimum roof pitch for a roofing application is 3" of rise per foot (3:12).
5. Oil canning is not a cause for rejection.

FREIGHT: All prices are F.O.B. shipping point.

FREIGHT CHARGES: \$6.00 per square - \$60.00 minimum charge.

1. Stop over charge (for unloading delay in excess of 1½ hrs. Charged in ½ hr. increments)...\$90.00 per hour.
2. Job Site Delivery: \$75.00 Minimum.
3. Refer to price sheets for freight notes.

ABC is pleased to provide job site delivery to our customers. Customers requesting this service must have mechanized means to off-load the material (i.e. crane, forklift, gin pole). The job site location must be accessible to a vehicle 65' long and weighing up to 80,000 pounds. ABC reserves the right to refuse delivery at job sites where unsafe or impassable terrain or road conditions are present.

PRODUCT INFORMATION

29 GAUGE LOAD TABLES

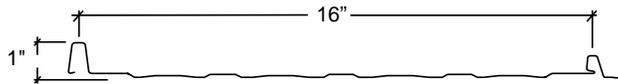

MINOR RIBS WITH STRIATIONS

Negative Design Loads

Span	ASTM E-1592	Design Load
FT	PSF	PSF
1.00	62.40	31.20
1.50	54.60	27.30
2.00	46.80	23.40
2.50	44.20	22.10
3.00	41.60	20.80

NOTES:

1. The above loads were derived from uplift tests done in accordance with ASTM E-1592
2. All values are interpolated and/or extrapolated from tests performed at spans of 1'-0", 2'-0" and 3'-0".
3. Design Load contains a 2.00 factor of safety.
4. These values do not consider fastener pullout or pullover. Attachment must be designed separately.
5. The use of any accessories, including fasteners, other than those provided by the manufacturer may damage panels, void all warranties and will void all engineering data.
6. This material is subject to change without notice. Please contact ABC for most current data.

Descriptions and specifications contained herein were in effect at the time this publication was approved for printing. ABC reserves the right to discontinue products at any time or change specifications and/or designs without notice and without incurring obligation. Application details are for illustration purposes only and may not be appropriate for all environmental conditions, building designs, or panel profiles. Projects should be engineered to conform to applicable building codes, regulations and accepted industry practices.

PRODUCT INFORMATION

UL[®] TECHNICAL DATA



Construction #529 SL 16[®] over Plywood

1. Metal Panels (29 gauge or heavier)—16" wide, continuous over two or more spans.
2. Substructure (Plywood)—plywood decking to be a nominal 5/8" thick.
3. Fasteners—No. 10 X 1" long No. 2 Phillips pancake head wood screw spaced 1'-0" O.C.
4. Joists—joists spaced 2' O.C. may be one of the following:
 - A. Nom. 2" x 6" wood joists No. 2 or better.
 - B. Nom. 2" x 4" wood when used on a top cord of a wood truss, No. 2 or better.
 - C. Light gauge structural steel framing with the member against the plywood to be a minimum No. 22 msg coated steel.

FIRE RESISTANCE RATING

External Fire Exposure: Class A

Mechanically attached metal roof panels—type SL 16[®] 16" (29 msg). Secured by No. 10 X 1" No. 2 Phillips pancake head wood screw.

For use in: "Design Nos. P224, P225, P227, P230, P233, P237, P265, P268, P508, P510, P512, P701, P711, P715, P717, P720, P722, P724, P726, P731, P734, P736, P801, P803, P814, P815, P819, P821 and P823".

See **UL FIRE RESISTANCE DIRECTORY** for details of illustrations and fire resistance hourly ratings.

IMPACT RESISTANCE

UL Classification as to Impact Resistance: Class 4

CAUTION

For UL 90 Rated Roofs, the above requirements must be followed. See UL Roofing Materials and Systems Directory for additional requirements. If you have any questions, call ABC before proceeding.

PRODUCT INFORMATION

PRODUCT CHECKLIST

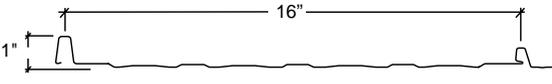
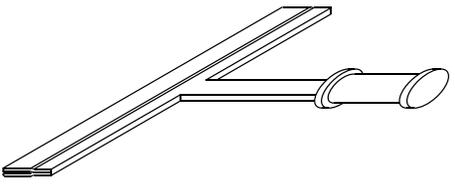
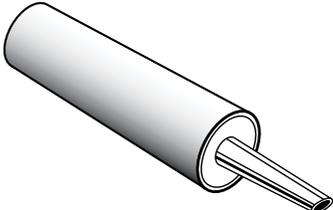
<p>SL 16® Series</p> <p style="text-align: center;">MINOR RIBS WITH STRIATIONS</p> 		
<p>16" Outside Closure</p> <ul style="list-style-type: none"> • Outside Closure • Contains Adhesive  <p style="text-align: right;">HW-492 <input type="checkbox"/></p>	<p>Panel Hemming Tool</p> <ul style="list-style-type: none"> • Width: 19"  <p style="text-align: right;">HW-602 <input type="checkbox"/></p>	
<p>Tape Sealer - Tri-Bead Tape</p> <ul style="list-style-type: none"> • Width: 7/8" • Thickness: 3/16" • Length: 25'-0" • 8 Per Carton  <p style="text-align: right;">HW-504 <input type="checkbox"/></p> <p>NOTES: Sold by carton only</p>	<p>Tape Sealer - Triple Bead Tape</p> <ul style="list-style-type: none"> • Width: 2 1/2" • Thickness: 3/16" • Length: 20'-0" • 6 Per Carton  <p style="text-align: right;">HW-502 <input type="checkbox"/></p> <p>NOTES: Sold by carton only</p>	<p>Tube Sealant</p> <ul style="list-style-type: none"> • Urethane Sealant • 11 oz. Tubes • 30 Per Carton  <p style="text-align: right;"> HW-540 - White <input type="checkbox"/> HW-541 - Gray <input type="checkbox"/> HW-542 - Bronze <input type="checkbox"/> </p> <p>NOTES: 25' per tube at 1/4" bead</p>

PRODUCT INFORMATION

PRODUCT CHECKLIST

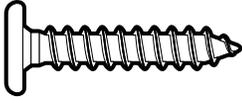
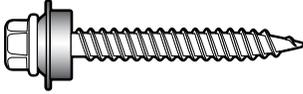
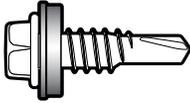
<p>Pancake Head</p> <ul style="list-style-type: none"> • Panel to Substructure at Fastener Flange • #2 Phillips • 250 Per Bag  <p>#13 - 10 x 1" <input type="checkbox"/></p>	<p>Wood Fastener</p> <ul style="list-style-type: none"> • Panel to wood • Head size ¼" • 250 Per Bag  <p>8A - 10 x 1" <input type="checkbox"/> 8 - 10 x 1½" <input type="checkbox"/> 8B - 10 x 2" <input type="checkbox"/> 8C - 10 x 2½" <input type="checkbox"/></p>
<p>Lap-Tek</p> <ul style="list-style-type: none"> • Trim Fastener • Head Size ⅝" • 250 Per Bag  <p>4A - 14 x ⅞" <input type="checkbox"/></p>	<p>Long Life Wood Fastener</p> <ul style="list-style-type: none"> • Panel to wood • Head size ⅝" • 250 Per Bag  <p>*Special order NOTES: Other Sizes Available.</p> <p>#9A - 10 x 1" <input type="checkbox"/> #9 - 10 x 1½" <input type="checkbox"/></p>
<p>Pop Rivet</p> <ul style="list-style-type: none"> • Stainless Steel Trim • 250 Per Bag  <p>#14 - ⅛ x ⅜" <input type="checkbox"/></p>	<p>Type A</p> <ul style="list-style-type: none"> • Panel to Plywood at Exposed Locations • Head Size ⅝" • 250 Per Bag  <p>#18 - 14 x 1" <input type="checkbox"/> #18B - 14 x 1½" <input type="checkbox"/> #18C - 14 x 2" <input type="checkbox"/></p>

PRODUCT INFORMATION

PRODUCT CHECKLIST

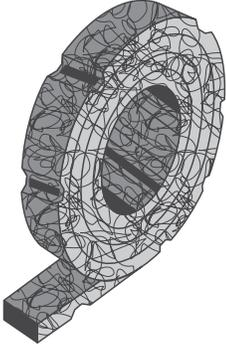
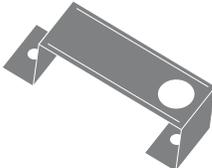
<p>Profile Vent</p> <ul style="list-style-type: none"> 100' Roll  <p style="text-align: right;">HW-116SL16 <input type="checkbox"/></p>	<p>Profile Vent Anchor Clip</p> <ul style="list-style-type: none"> Two per panel Sold in quantities of 25 pieces  <p style="text-align: right;">HW-2076 <input type="checkbox"/></p>
--	--

One Piece Magnetic Socket

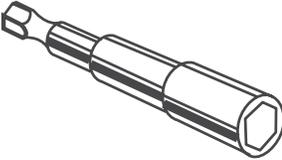

HW-606 - 1/4"
HW-605 - 5/16"

Rubber Roof Jack

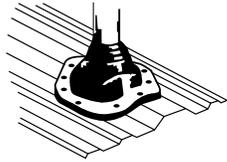

Touch Up Paint - Brush Top Can

- 2 oz. bottle with brushes
- Standard Colors
- Recommended for minor scratch cover only



HW-304

PIPE SIZE	PART NUMBER	TEMP. RANGE	BASE DIM
1/4" - 2"	HW-1000	-65° - +212°	4 1/2"
1/4" - 5"	HW-1001	-65° - +212°	8"
4" - 7"	HW-1002	-65° - +212°	11"
6" - 11"	HW-1003	-65° - +212°	14"
7" - 13"	HW-1004	-65° - +212°	17"

Retrofit Rubber Roof Jack



PIPE SIZE	PART NUMBER	TEMP. RANGE	BASE DIM
1/2" - 4"	HW-1005	-65° - +212°	8 3/16"
4" - 9 1/4"	HW-1006	-65° - +212°	14 1/4"
9 1/4" - 16 1/4"	HW-1007	-65° - +212°	21 1/2"

High Temperature per special order. Please inquire.

PRODUCT INFORMATION

EXPOSED FASTENER TRIM

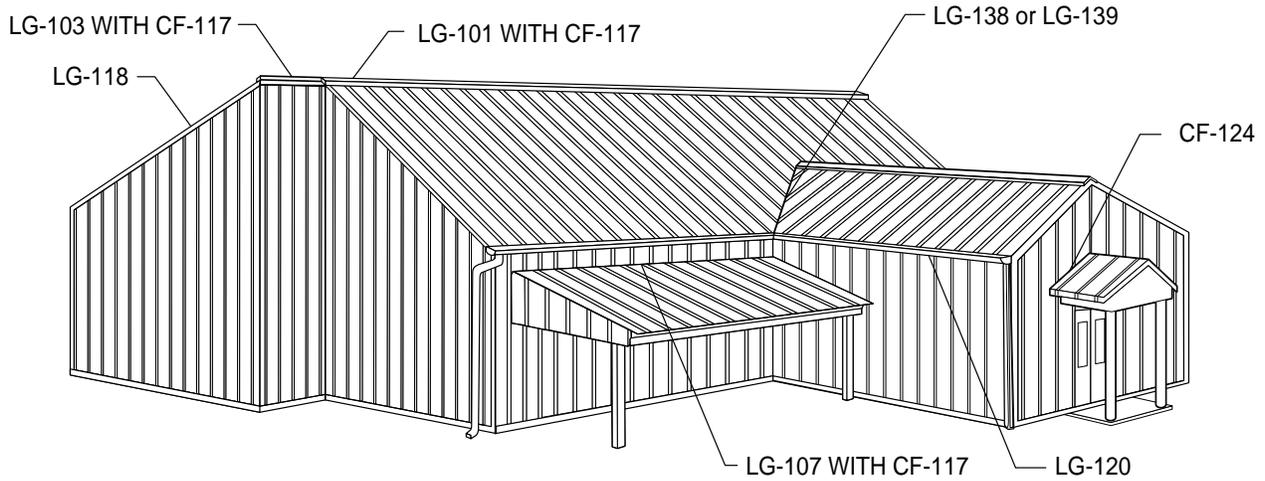

LG-101
PLAIN RIDGE CAP

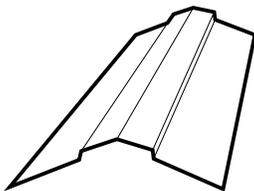

LG-103
DENVER PEAK

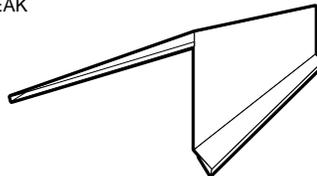

LG-107
DENVER ENDWALL FLASH

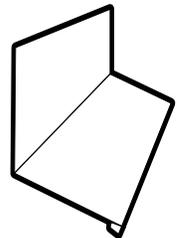

LG-118
DENVER GABLE

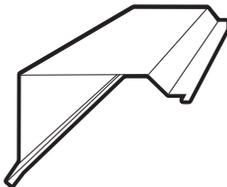

LG-120
DENVER EAVE

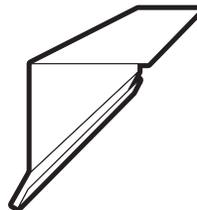

CF-124
SIDEWALL FLASHING

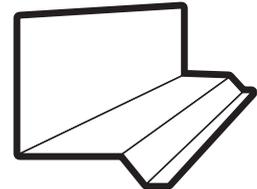

CF-115
RAKE TRIM

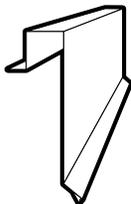

LG-138
"W" FORMED VALLEY
LG-139

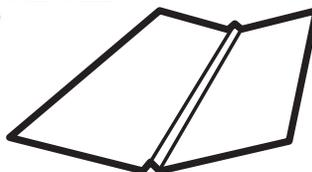

CF-117
ZEE CLOSURE

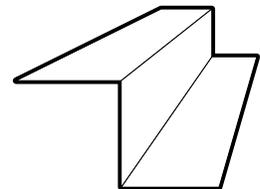

PRODUCT INFORMATION

EXPOSED FASTENER TRIM PRODUCT CHECKLIST

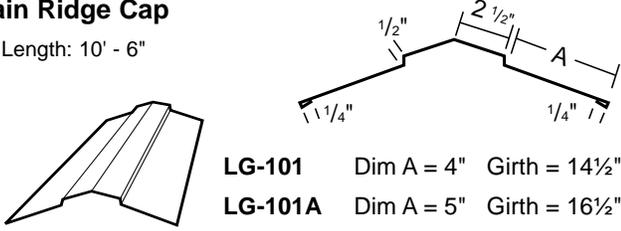
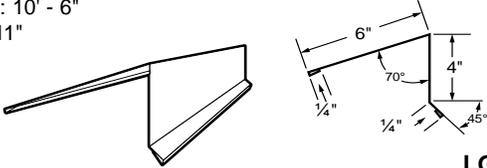
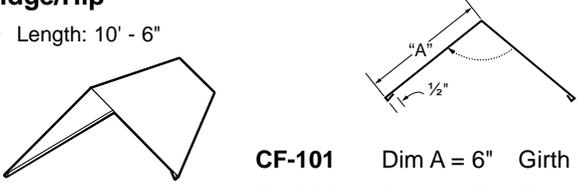
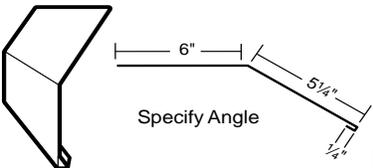
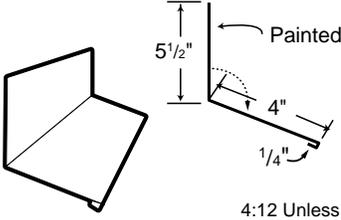
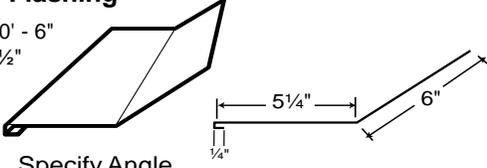
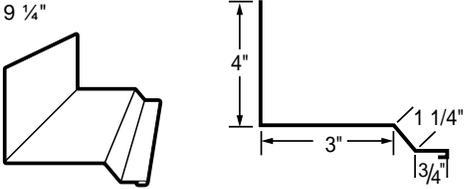
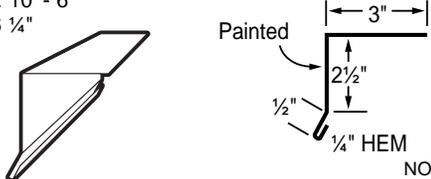
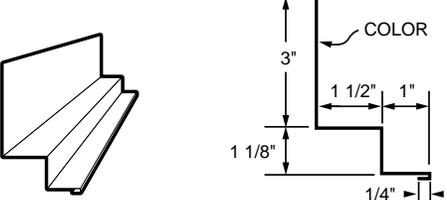
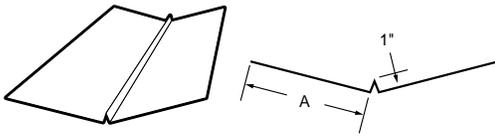
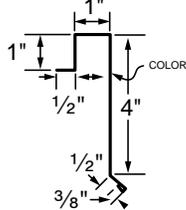
<p>Plain Ridge Cap</p> <ul style="list-style-type: none"> Length: 10' - 6"  <p>LG-101 Dim A = 4" Girth = 14 1/2" <input type="checkbox"/></p> <p>LG-101A Dim A = 5" Girth = 16 1/2" <input type="checkbox"/></p> <p>LG-101B Dim A = 6" Girth = 18 1/2" <input type="checkbox"/></p> <p>LG-101C Dim A = 7" Girth = 20 1/2" <input type="checkbox"/></p> <p>4 1/2 PITCH</p>	<p>Denver Peak Trim</p> <ul style="list-style-type: none"> Length: 10' - 6" Girth: 11"  <p>LG-103 <input type="checkbox"/></p>
<p>Ridge/Hip</p> <ul style="list-style-type: none"> Length: 10' - 6"  <p>CF-101 Dim A = 6" Girth = 13" <input type="checkbox"/></p> <p>CF-101A Dim A = 7" Girth = 15" <input type="checkbox"/></p> <p>CF-101B Dim A = 8" Girth = 17" <input type="checkbox"/></p> <p>NOTE: Specify Angle/Specify HIP or RIDGE</p>	<p>Upper Gambrel Flashing</p> <ul style="list-style-type: none"> Length: 10' - 6" Girth: 11 1/2"  <p>Specify Angle</p> <p>LG-184 <input type="checkbox"/></p>
<p>Denver Endwall Flash</p> <ul style="list-style-type: none"> Length: 10' - 6" Girth: 9 3/4"  <p>Painted</p> <p>LG-107 <input type="checkbox"/></p> <p>4:12 Unless otherwise specified</p>	<p>Transition Flashing</p> <ul style="list-style-type: none"> Length: 10' - 6" Girth: 11 1/2"  <p>Specify Angle</p> <p>LG-185 <input type="checkbox"/></p>
<p>Sidewall Flashing</p> <ul style="list-style-type: none"> Length: 10' - 6" Girth: 9 1/4"  <p>CF-124 <input type="checkbox"/></p>	<p>Denver Eave Trim</p> <ul style="list-style-type: none"> Length: 10' - 6" Girth: 6 1/4"  <p>Painted</p> <p>LG-120 <input type="checkbox"/></p> <p>NOTE: Specify Angle</p>
<p>Universal Side Wall</p> <ul style="list-style-type: none"> Length: 10' - 6" Girth: 6 7/8"  <p>COLOR</p> <p>CF-118 <input type="checkbox"/></p>	<p>W Formed Valley</p> <ul style="list-style-type: none"> Length: 10' - 6"  <p>LG-138 Dim A = 9" Girth = 14 1/2" <input type="checkbox"/></p> <p>LG-139 Dim A = 14" Girth = 16 1/2" <input type="checkbox"/></p> <p>NOTE: Specify Angle</p>
<p>Rake Trim</p> <ul style="list-style-type: none"> Length: 10' - 6"  <p>COLOR</p> <p>CF-115 Dim A = 1" Girth = 7 1/4" <input type="checkbox"/></p> <p>CF-115A Dim A = 2" Girth = 8 1/4" <input type="checkbox"/></p>	

PRODUCT INFORMATION

CONCEALED FASTENER TRIM

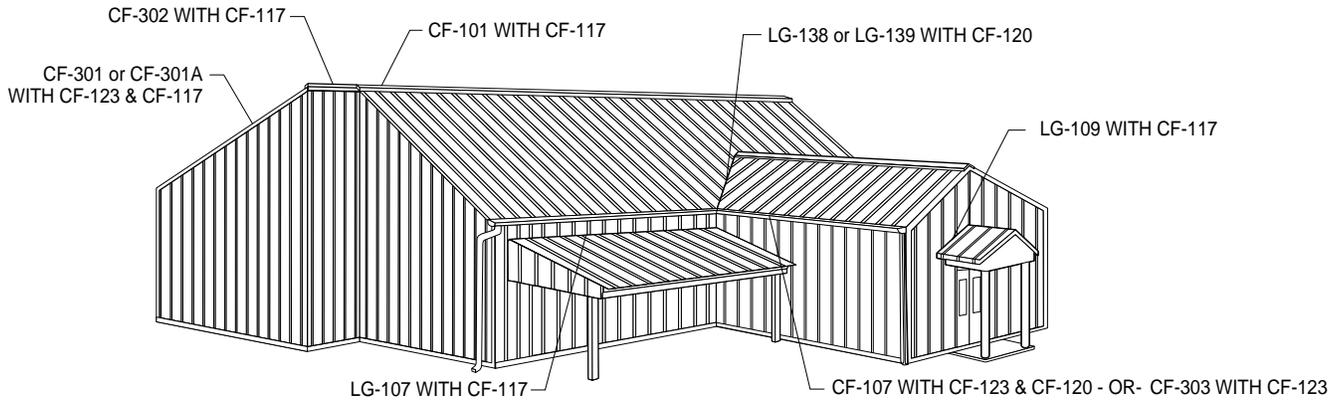

CF-302
CONCEALED PEAK TRIM

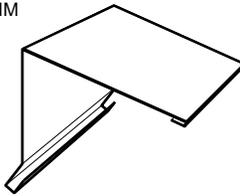

CF-101
RIDGE/HIP

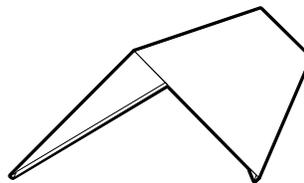

CF-120
OFFSET CLEAT

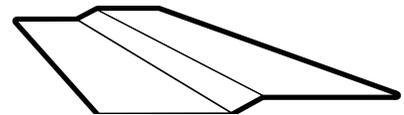

LG-109
DENVER SIDEWALL FLASHING

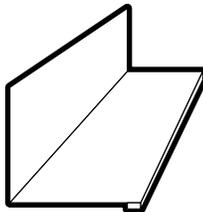

CF-123
CONTINUOUS CLEAT

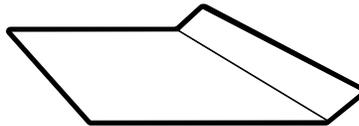

CF-301
CF-301A
CONCEALED RAKE

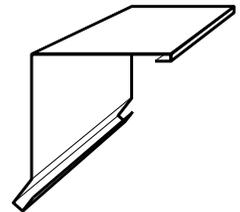

CF-107
CONCEALED EAVE TRIM

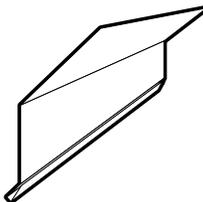

LG-138
LG-139
"W" FORMED VALLEY

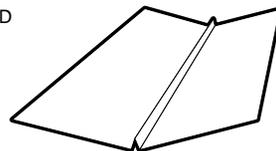

CF-117
ZEE CLOSURE

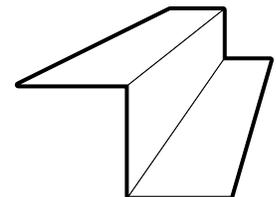

CF-303
EAVE TRIM WITH DRIP EDGE

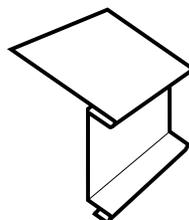

LG-107
DENVER ENDWALL FLASHING

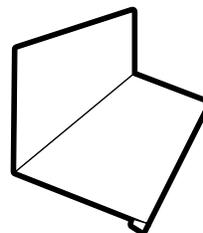

PRODUCT INFORMATION

CONCEALED FASTENER TRIM PRODUCT CHECKLIST

Ridge/Hip

- Length: 10' - 6"

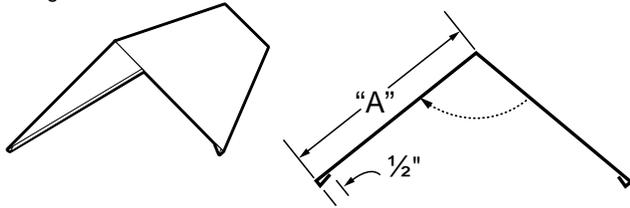

- CF-101** Dim A = 6" Girth = 13"
- CF-101A** Dim A = 7" Girth = 15"
- CF-101B** Dim A = 8" Girth = 17"

NOTE: Specify Angle/Specify HIP or RIDGE

Concealed Peak Trim

- Length: 10' - 6"
- Girth: 11 3/8"
- Closed hem on request

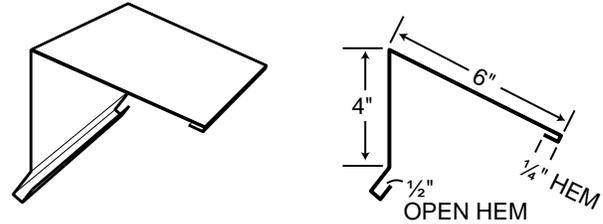

CF-302

Concealed Rake

- Length: 10' - 6"
- Use with CF-117 and CF-123

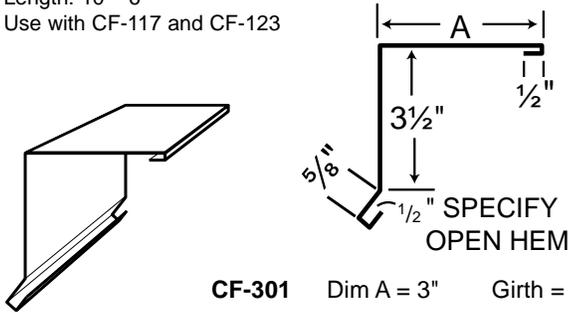

- CF-301** Dim A = 3" Girth = 8 1/8"
- CF-301A** Dim A = 6" Girth = 11 1/8"

Concealed Eave Trim

- Length: 10' - 6"
- Girth: 7"
- Use with CF-120 and CF-123

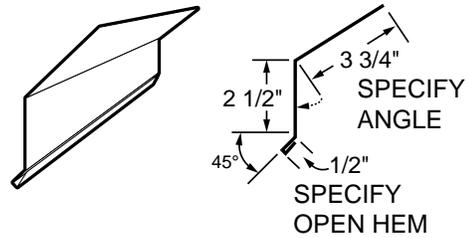

NOTE: Specify Angle

Denver Sidewall Flashing

- Length: 10' - 6"
- Girth: 8 1/4"
- Use with CF-117

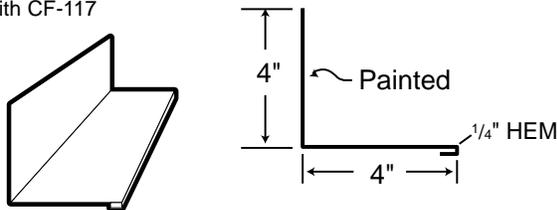

LG-109

Eave Trim with Drip Edge

- Length: 10' - 6"
- Girth: 9 5/8"
- Use with CF-123

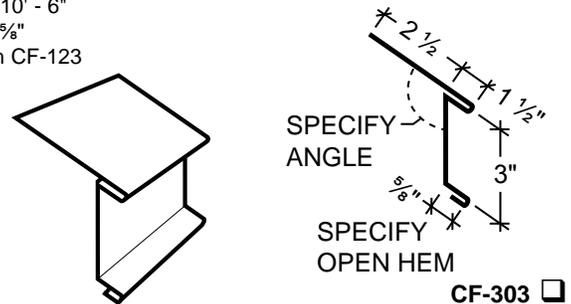

CF-303

Denver Endwall Flash

- Length: 10' - 6"
- Girth: 9 3/4"
- Use with CF-117

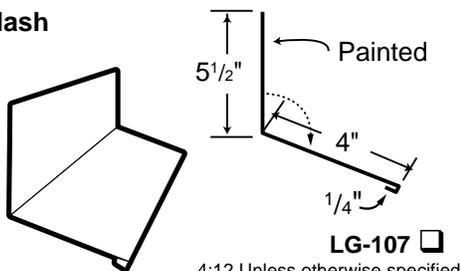

LG-107

4:12 Unless otherwise specified

Square Eave Trim with Drip Edge

- Length: 10' - 6"
- Girth: 9 5/8"

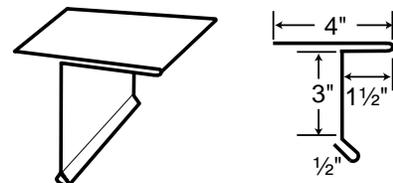

CF-126

PRODUCT INFORMATION

CONCEALED FASTENER TRIM PRODUCT CHECKLIST

"W" Formed Valley

- Length: 10' - 6"
- Use with CF-120

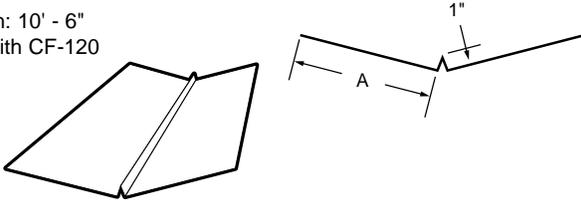

4:12 PITCH STANDARD UNLESS SPECIFIED OTHERWISE

LG-138 Dim A = 9" Girth = 20"

LG-139 Dim A = 14" Girth = 30"

Offset Cleat

- Length: 10' - 6"
- Girth: 3 1/2"

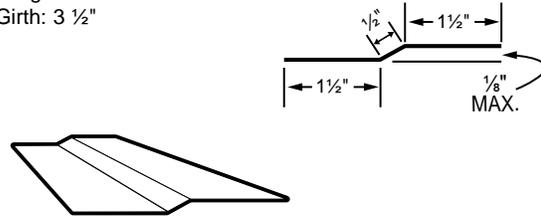

CF-120

NOTE: Concealed trim made out of 29 gauge Galvalume Plus[®].

Zee Closure

- Length: 10' - 6"
- Girth: 3"
- Field cut as needed
- Used as outside closure

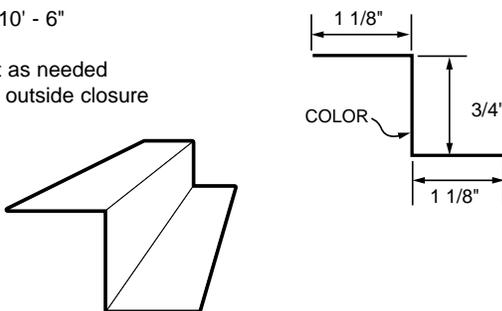

CF-117

Continuous Cleat

- Length: 10' - 6"
- Girth: 3"

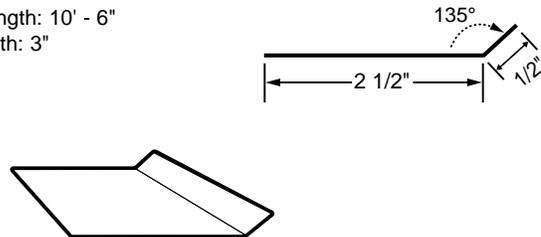

CF-123

Counter Flash

- Length: 10' - 6"
- Girth: 5 1/2"

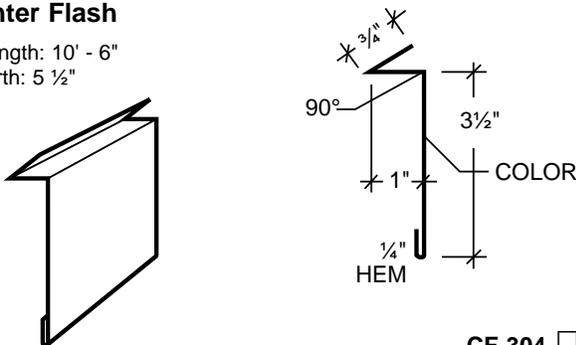

CF-304

Rib Cover

- Length: 0' - 8"

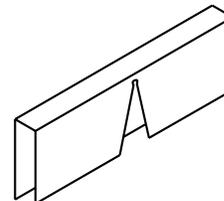

CF-119

Flat Sheet

40 7/8" x 126" Galvanized and Color
40 7/8" x 126" Galvalume Plus[®]

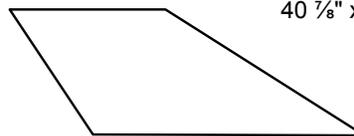

*Skidding charge of \$42.00 will be added

Drip Edge

- Length: 10' - 6"
- Girth: 7 3/8"

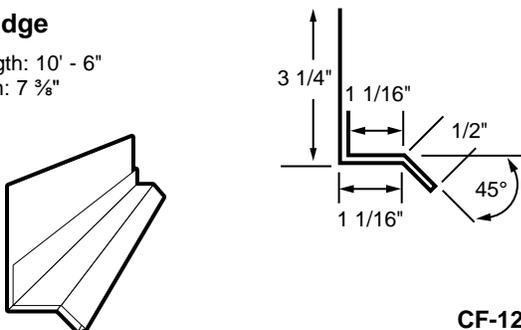

CF-121

Roll Valley

- Length: 50' - 0"
- 29 Gauge
- Width: 20 3/16"

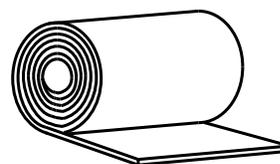

Available in all colors

PRODUCT INFORMATION

DOWNSPOUT CONNECTIONS

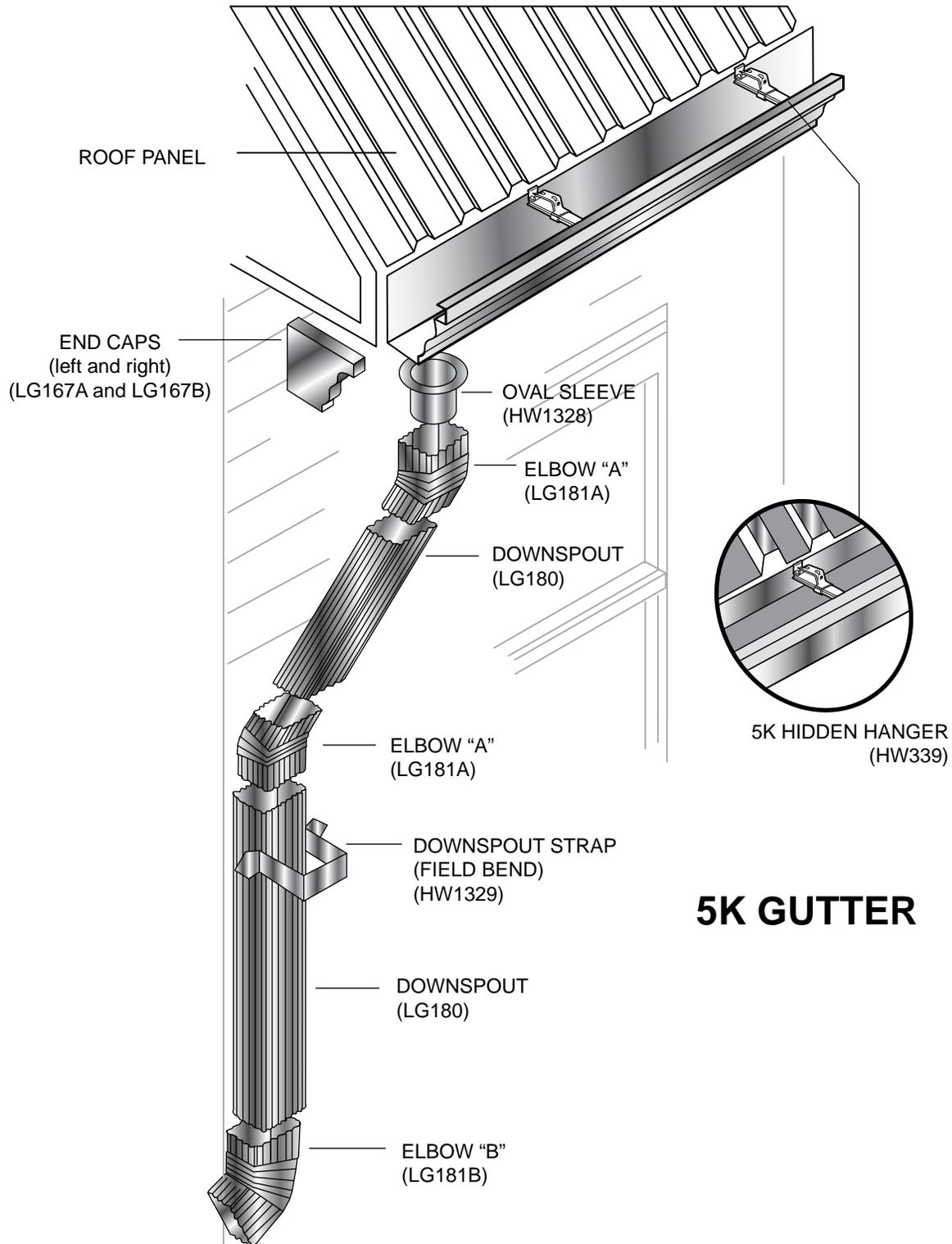

5K GUTTER

PRODUCT INFORMATION

PRODUCT CHECKLIST

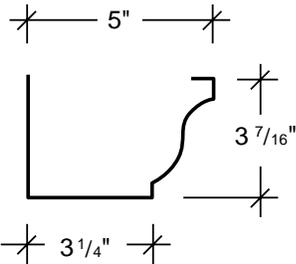
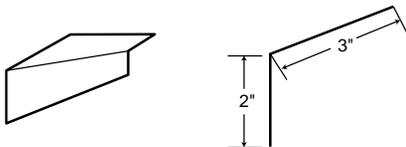
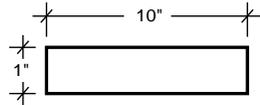
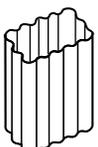
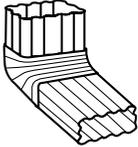
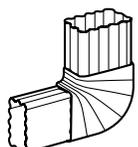
<p>5K GUTTER</p> <div style="display: flex; align-items: center; justify-content: center;">  <div style="margin-left: 20px;"> <p>GUTTER</p> </div> </div> <table style="width: 100%; margin-top: 10px;"> <thead> <tr> <th style="width: 30%;"></th> <th style="width: 15%;">LENGTH</th> <th style="width: 10%;">GIRTH</th> <th style="width: 10%;">WEIGHT</th> <th style="width: 35%;">PART NUMBER</th> </tr> </thead> <tbody> <tr> <td>GUTTER</td> <td>16'-0"</td> <td>12"</td> <td>9.96#</td> <td>LG-161 <input type="checkbox"/></td> </tr> <tr> <td>ENDS/LEFT</td> <td>N/A</td> <td>N/A</td> <td>.1 #</td> <td>LG-167A <input type="checkbox"/></td> </tr> <tr> <td>ENDS/RIGHT</td> <td>N/A</td> <td>N/A</td> <td>.1 #</td> <td>LG-167B <input type="checkbox"/></td> </tr> </tbody> </table> <p style="font-size: small; margin-top: 5px;">Available in Standard Colors</p>			LENGTH	GIRTH	WEIGHT	PART NUMBER	GUTTER	16'-0"	12"	9.96#	LG-161 <input type="checkbox"/>	ENDS/LEFT	N/A	N/A	.1 #	LG-167A <input type="checkbox"/>	ENDS/RIGHT	N/A	N/A	.1 #	LG-167B <input type="checkbox"/>
	LENGTH	GIRTH	WEIGHT	PART NUMBER																	
GUTTER	16'-0"	12"	9.96#	LG-161 <input type="checkbox"/>																	
ENDS/LEFT	N/A	N/A	.1 #	LG-167A <input type="checkbox"/>																	
ENDS/RIGHT	N/A	N/A	.1 #	LG-167B <input type="checkbox"/>																	
<p>GUTTER APRON</p> <ul style="list-style-type: none"> Length 10'-6" Girth 5" Weight 2.70# <div style="display: flex; align-items: center; justify-content: center; margin-top: 10px;">  </div> <p style="text-align: right; margin-top: 10px;">LG-149 <input type="checkbox"/></p>	<p>INSIDE-OUTSIDE SQUARE CORNER</p> <div style="display: flex; justify-content: space-around; align-items: center; margin-top: 10px;">   </div> <div style="display: flex; justify-content: space-around; margin-top: 10px;"> <p>INSIDE OUTSIDE</p> <p>LG-168 <input type="checkbox"/> LG-168A <input type="checkbox"/></p> </div> <p style="font-size: x-small; margin-top: 5px;">White only</p>	<p>DOWNSPOUT STRAP (FIELD BEND)</p> <ul style="list-style-type: none"> Length 1" Girth 10" Weight .07# <div style="display: flex; align-items: center; justify-content: center; margin-top: 10px;">  </div> <p style="text-align: right; margin-top: 10px;">HW-1329 <input type="checkbox"/></p>																			
<p>5K 4" X 3" DOWNPOUT</p> <ul style="list-style-type: none"> Length 10' Girth 10 1/2" Weight 5.60# <div style="display: flex; align-items: center; justify-content: center; margin-top: 10px;">  </div> <p style="text-align: right; margin-top: 10px;">LG-180 <input type="checkbox"/></p>	<p>5K 4" X 3" ELBOW</p> <ul style="list-style-type: none"> Weight .5# <div style="display: flex; align-items: center; justify-content: center; margin-top: 10px;">  </div> <p style="text-align: right; margin-top: 10px;">TYPE A LG-181A <input type="checkbox"/></p>	<p>5K 4" X 3" ELBOW</p> <ul style="list-style-type: none"> Weight .5# <div style="display: flex; align-items: center; justify-content: center; margin-top: 10px;">  </div> <p style="text-align: right; margin-top: 10px;">TYPE B LG-181B <input type="checkbox"/></p>																			
<p>5K HIDDEN HANGER</p> <ul style="list-style-type: none"> Length 5" Weight .02# <div style="display: flex; align-items: center; justify-content: center; margin-top: 10px;">  </div> <p style="text-align: right; margin-top: 10px;">HW-339 <input type="checkbox"/></p>	<p>3" OVAL OUTLET TUBES</p> <ul style="list-style-type: none"> Weight .05# <div style="display: flex; align-items: center; justify-content: center; margin-top: 10px;">  </div> <p style="text-align: right; margin-top: 10px;">HW-1328 <input type="checkbox"/></p>																				

PRODUCT INFORMATION

HOW TO ORDER SPECIAL TRIM DEGREES BASED ON ROOF PITCH

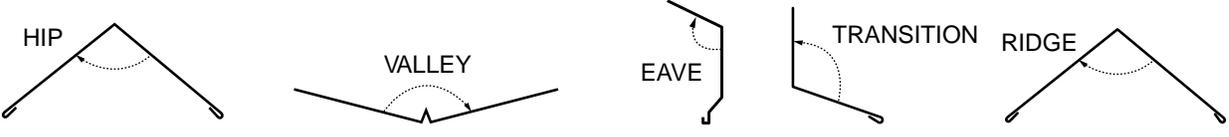
												
	ROOF SLOPE											
	1:12	2:12	3:12	4:12	5:12	6:12	7:12	8:12	9:12	10:12	11:12	12:12
HIP AND VALLEY	173°	166°	160°	154°	148°	143°	138°	133°	129°	126°	123°	120°
EAVE AND ENDWALL	94°	99°	104°	108°	112°	116°	120°	123°	126°	129°	132°	135°
RIDGE	170°	161°	152°	143°	135°	127°	120°	113°	106°	100°	95°	90°

NOTES:

1. Always indicate the dimension of each segment.
2. Always indicate each angle in degrees
3. Indicate the number of hemmed edges
4. Always indicate the exposed or colored side of each trim piece.
5. Calculate girth, which is the total width of trim piece.

TRANSITION FLASHING

	FROM											
	12:12	11:12	10:12	9:12	8:12	7:12	6:12	5:12	4:12	3:12	2:12	1:12
1:12	139°	142°	144°	147°	150°	154°	158°	162°	168°	172°	177°	
2:12	144°	147°	149°	152°	156°	159°	163°	167°	171°	176°		
3:12	149°	151°	154°	157°	160°	163°	167°	171°	175°			
4:12	153°	156°	158°	161°	164°	168°	172°	176°				
5:12	157°	160°	162°	165°	168°	172°	176°					
6:12	161°	164°	166°	169°	172°	176°						
7:12	165°	167°	170°	173°	176°							
8:12	168°	171°	173°	176°								
9:12	172°	174°	177°									
10:12	175°	177°										
11:12	177°											
12:12												

DETAILS

PANEL ENGAGEMENT

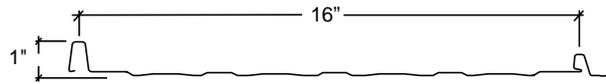

MINOR RIBS WITH STRIATIONS

PANEL PROFILE

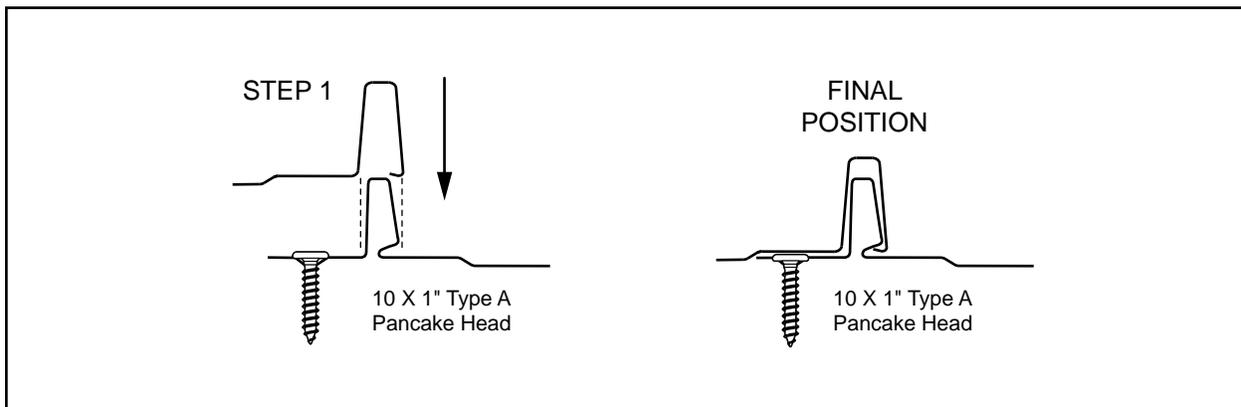

PANEL SIDELAP ENGAGEMENT

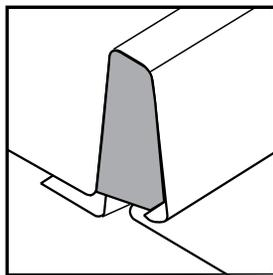

PANEL END WITH SEALANT

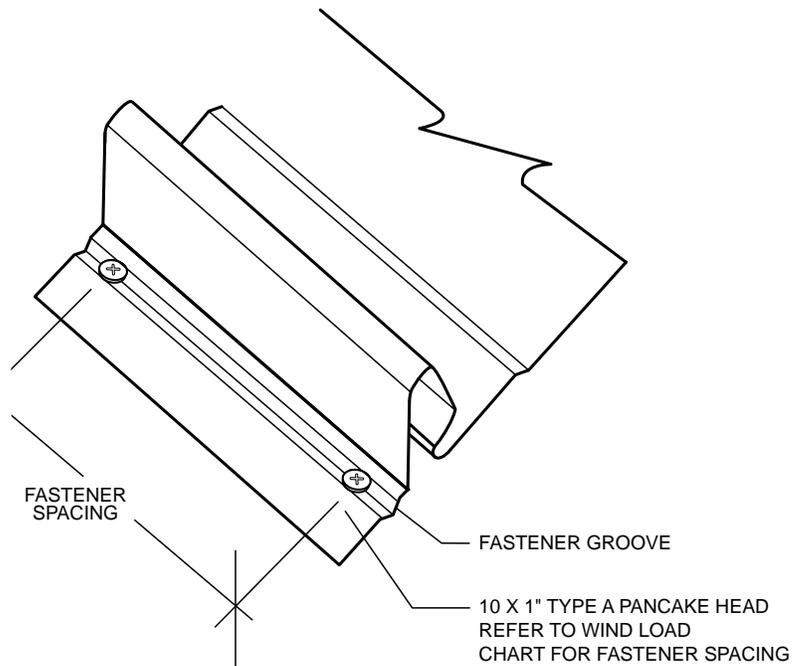

FASTENER INSTALLATION

NOTES:

1. Panels are produced with a fastener groove to facilitate fastener placement.
2. Total sidelap engagement without spreading the panel rib is essential. Always check panel module at each end before installing fasteners.
3. Fill panel ends with urethane sealant.

DETAILS

RIDGE

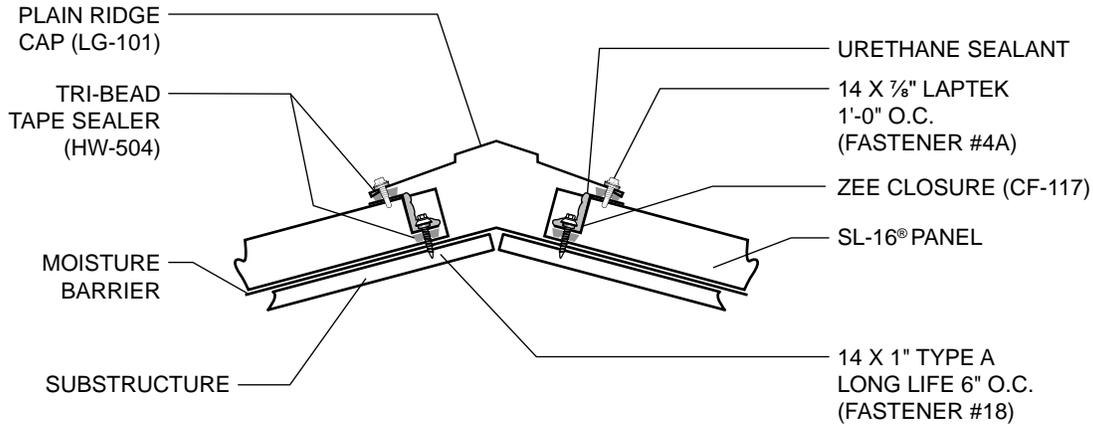

CROSS SECTION OF PLAIN RIDGE CAP

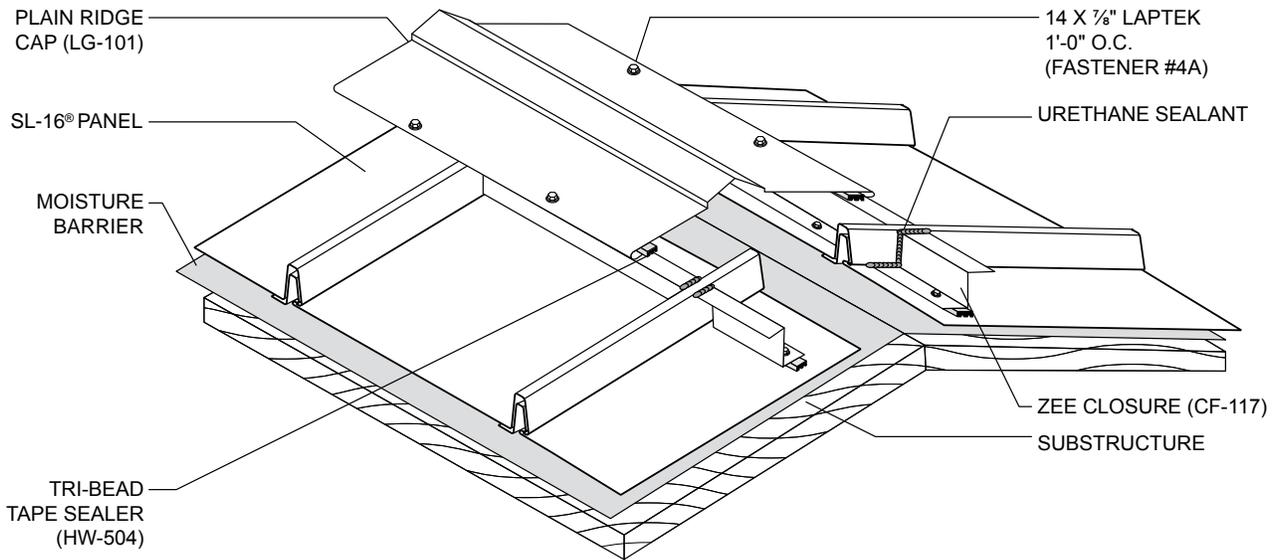

ISOMETRIC VIEW OF RIDGE

NOTES:

1. Field cut Zee closures to fit panel width.
2. Install tri-bead tape sealer to bottom leg of Zee closures and attach to panels with four 14 X 1" Type A fasteners per panel (three fasteners for 12" panel). Vertical leg of Zee closure should be 3" from center of ridge.
3. Seal ends of Zee closures with urethane sealant.
4. Attach ridge flash to Zee closures with 14 X 7/8" Long Life Laptek at 1'-0" O.C.

DETAILS

HIP

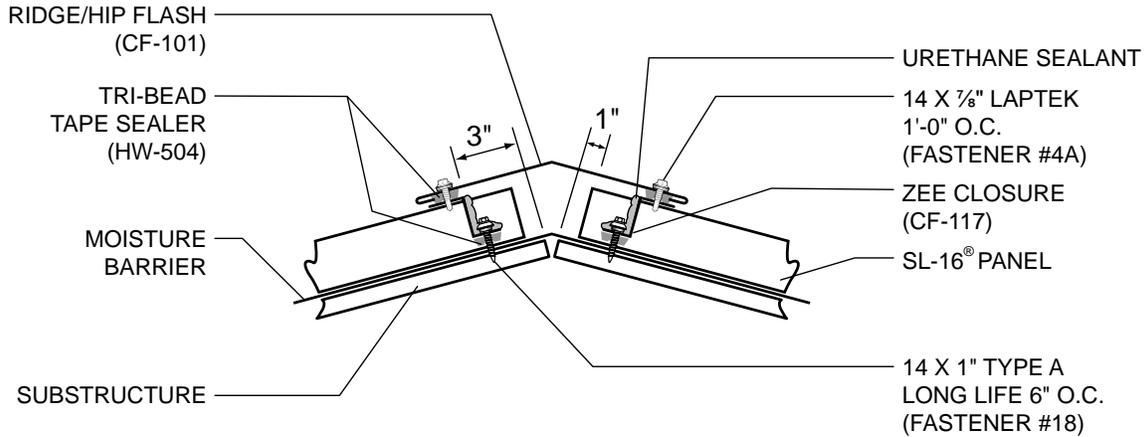

CROSS SECTION OF HIP

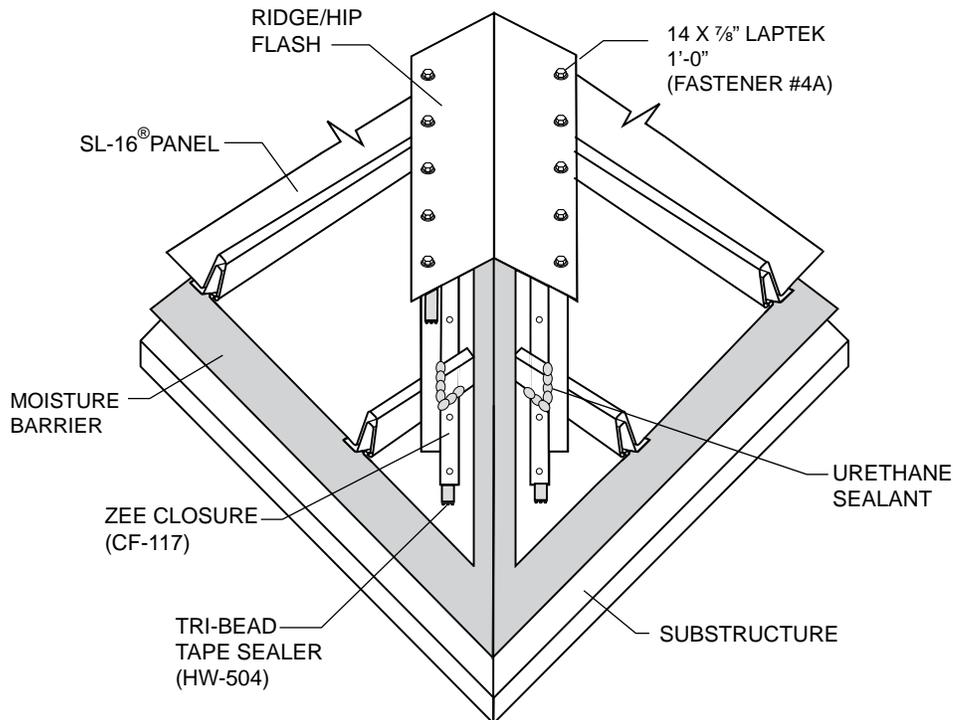

ISOMETRIC VIEW OF HIP

NOTES:

1. Bevel cut and install panels to follow angle of hip.
2. Field cut Zee closures to fit panel bevel width.
3. Install tri-bead tape sealer to bottom leg of Zee closures and attach to panels with 14 X 1" Type A fasteners 6" O.C. maximum. Vertical leg of Zee closure should be 3" from center of hip.
4. Seal ends of Zee closures with urethane sealant.
5. Attach Hip Flash to Zee closures with 14 X 7/8" Long Life Laptek at 1'-0" O.C.

DETAILS

PEAK TRIM

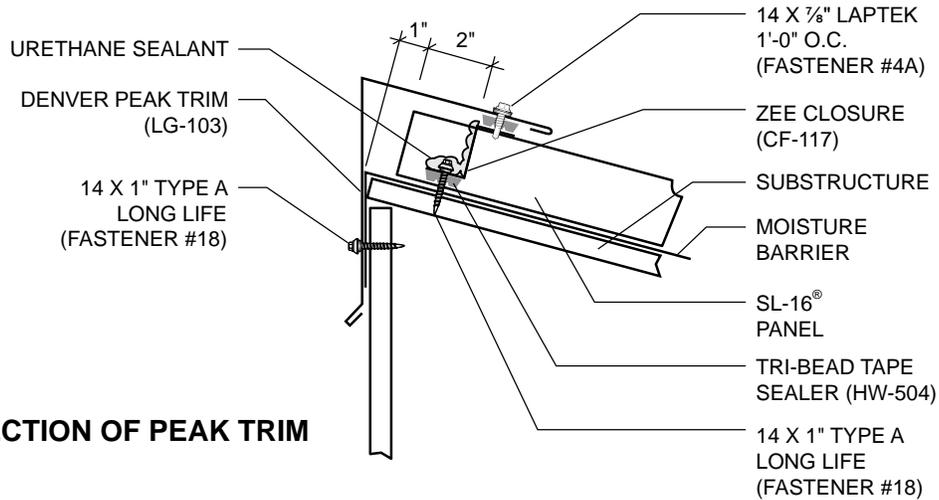

CROSS SECTION OF PEAK TRIM

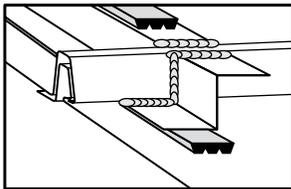

SEALANT DETAIL

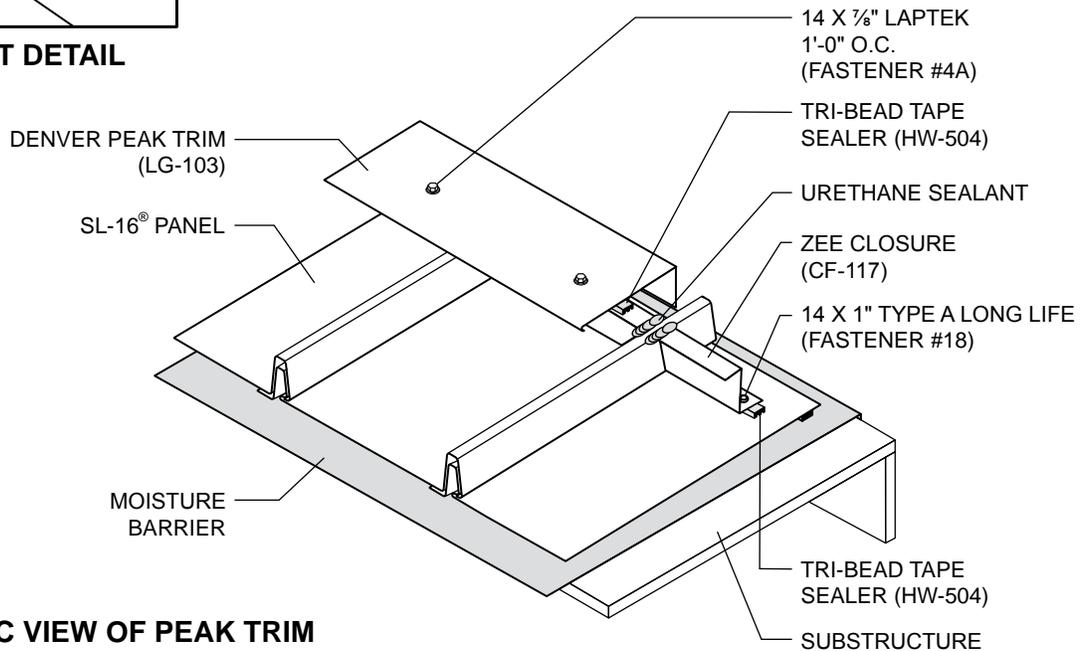

ISOMETRIC VIEW OF PEAK TRIM

NOTES:

1. Field cut Zee closures to fit panel width.
2. Install tri-bead tape sealer to bottom leg of Zee closures and attach to panels with four 14 X 1" Type A fasteners per panel (three fasteners for 12" panel). Vertical leg of Zee closure should be 3" from edge of peak.
3. Seal ends of Zee closures with urethane sealant.

DETAILS

EAVE

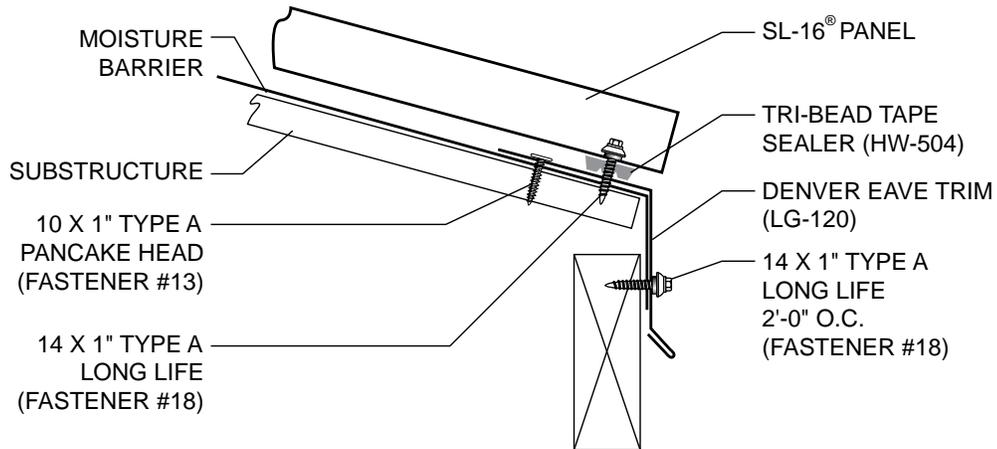

CROSS SECTION OF EAVE WITH EXPOSED FASTENERS

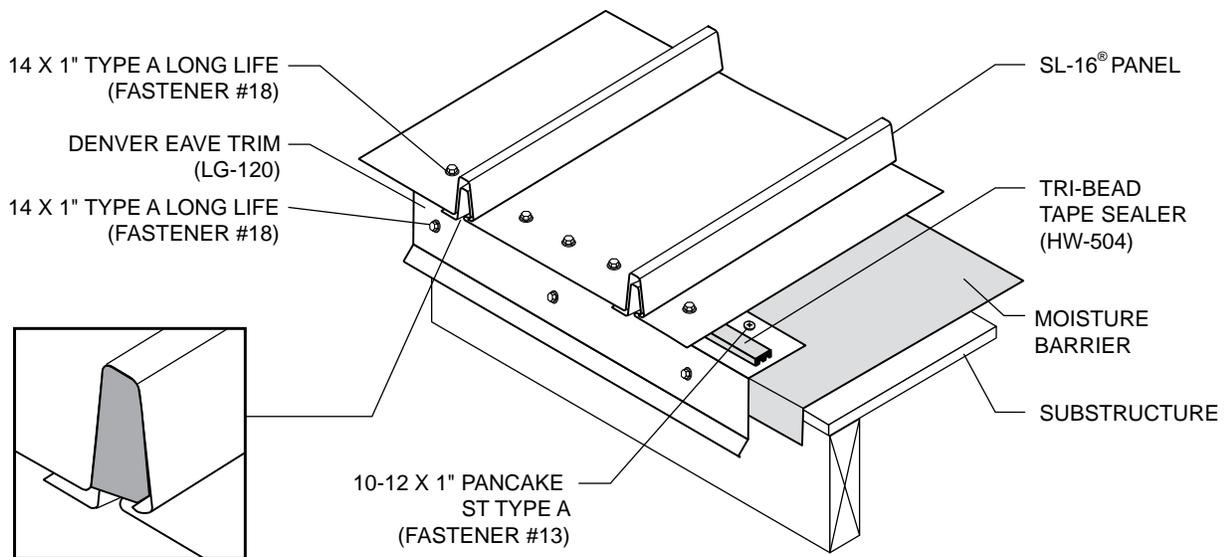

PANEL END WITH SEALANT

ISOMETRIC VIEW OF EAVE WITH EXPOSED FASTENERS

NOTES:

1. Attach eave trim to roof deck with two pancake head fasteners per 10' section.
2. Install tri-bead tape sealer along top leg of eave trim.
3. Attach panel at eave with four 14 X 1" Type A Long Life fasteners
4. Fill ends of panels with urethane sealant.

DETAILS

GUTTER

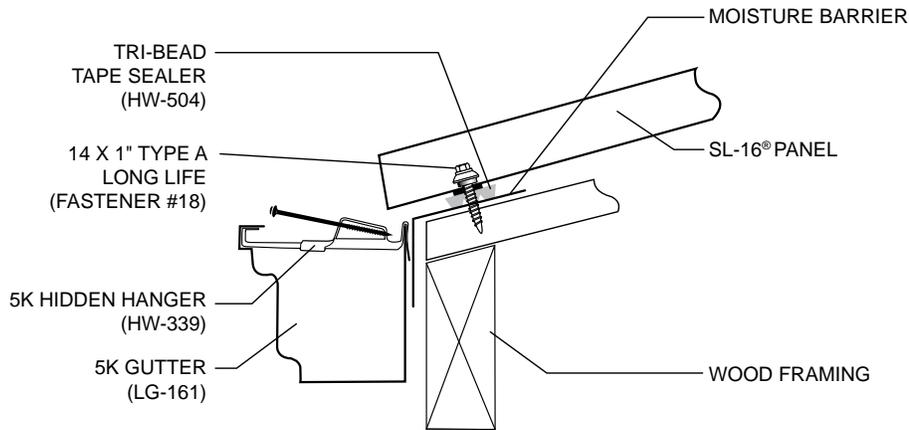

CROSS SECTION OF EAVE WITH 5K GUTTER

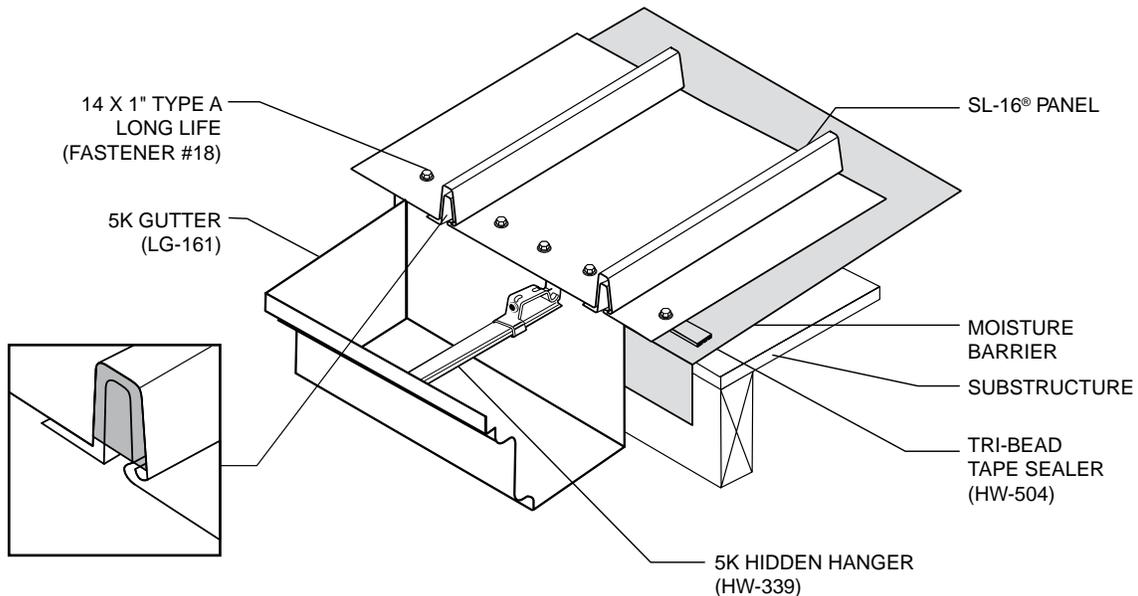

PANEL END WITH SEALANT

ISOMETRIC VIEW OF EAVE WITH 5K GUTTER

NOTES:

1. Use hidden hangers to attach 5K Gutter (LG161) to fascia board.
2. In areas of extreme ice or snow build-up, consider eliminating the gutter and using eave trim.

DETAILS

RAKE

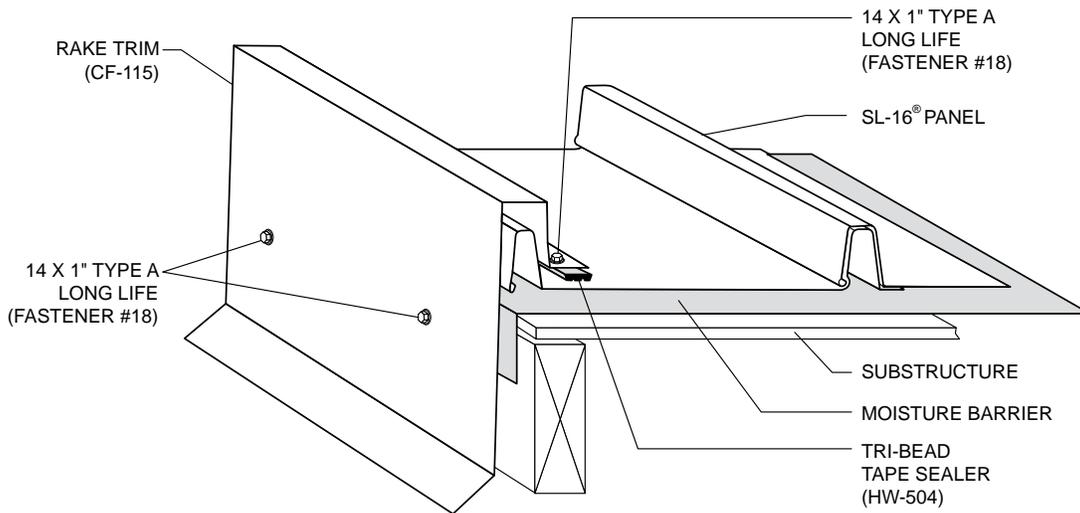
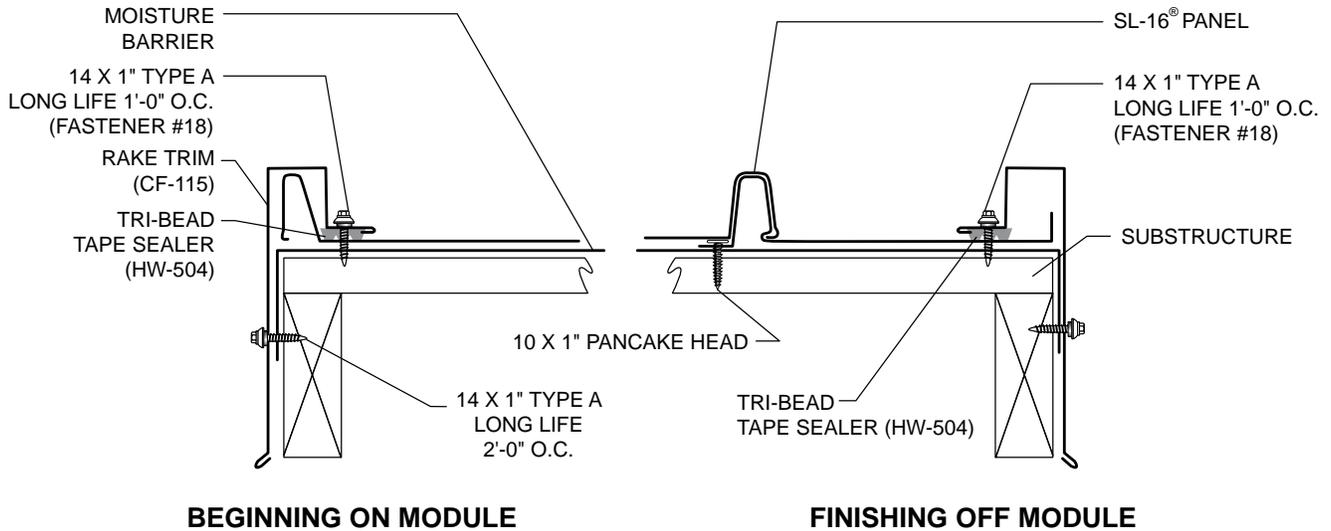

ISOMETRIC VIEW OF BEGINNING ON MODULE

NOTES:

1. Install rake trim to roof with 14 X 1" Type A Long Life Fastener at 1'-0" O.C. Fasteners must go through tri-bead tape sealer.
2. When finishing off module, field bend a 1" leg up on panel before installing rake trim.

DETAILS

VALLEY

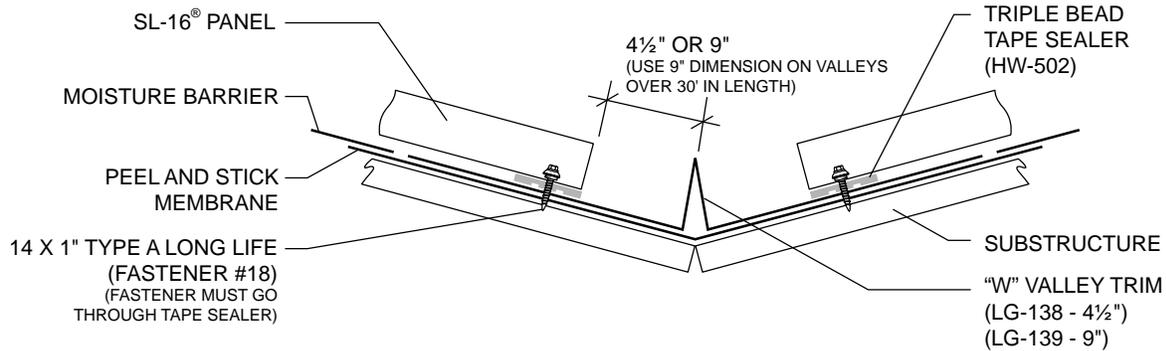

CROSS SECTION OF VALLEY WITH EXPOSED FASTENERS

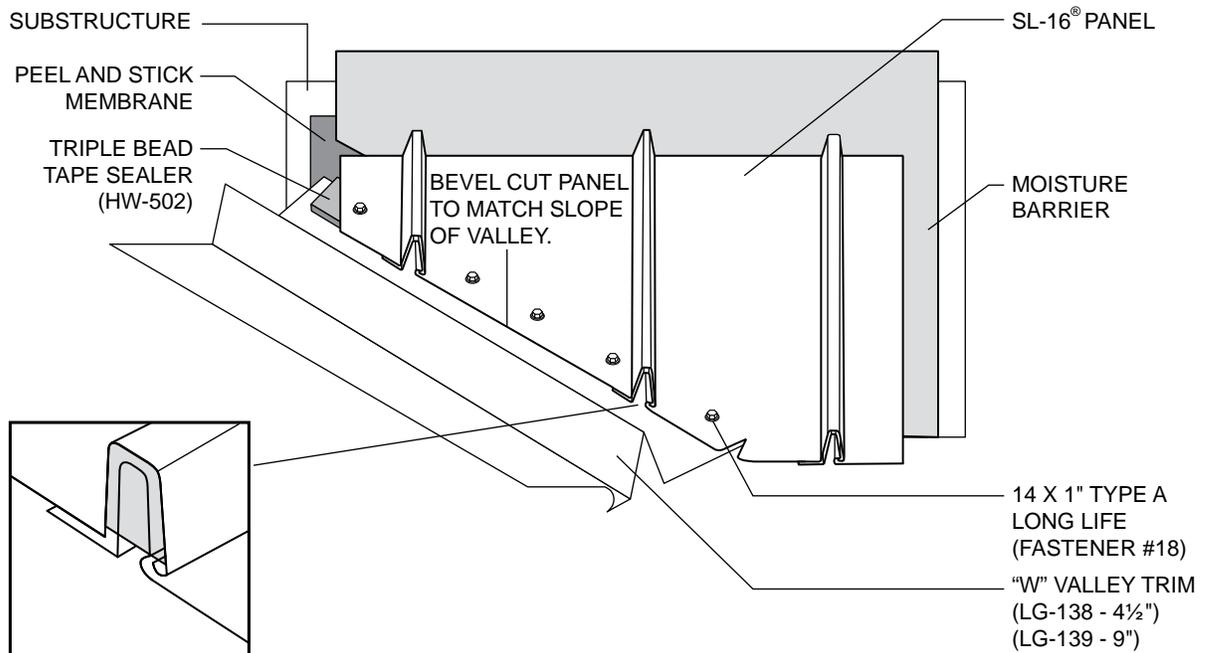

PANEL END WITH SEALANT

ISOMETRIC VIEW OF VALLEY WITH EXPOSED FASTENERS

NOTES:

1. For valleys 30' or less in length, use standard "W" valley trim (LG-138). For valleys over 30' in length use LG-139.
2. Apply triple-bead tape sealer to the valley trim parallel to the slope of the valley. Lower edge of tape sealer should be even with edge of roof panel.
3. Bevel cut panels to fit slope of valley.
4. Fasten panels to valley with 14 X 1" Type A Long Life fasteners at 4" O.C. maximum. Fasteners must go through tape sealer.
5. Fill ends of panels with urethane sealant.

DETAILS

SIDE WALL

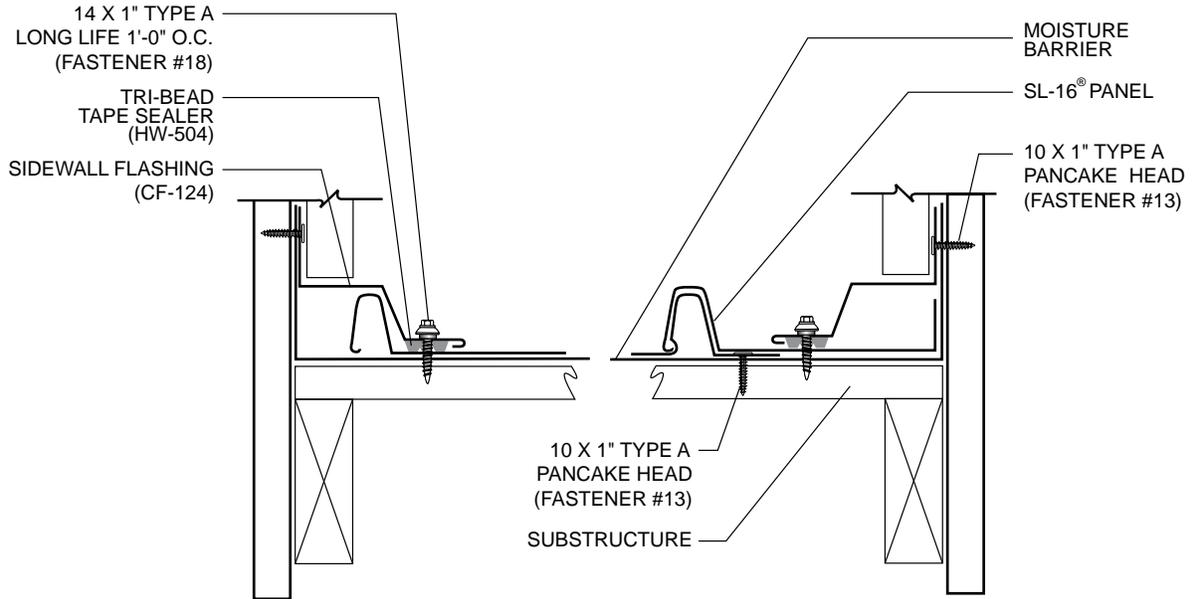

BEGINNING ON MODULE

FINISHING OFF MODULE

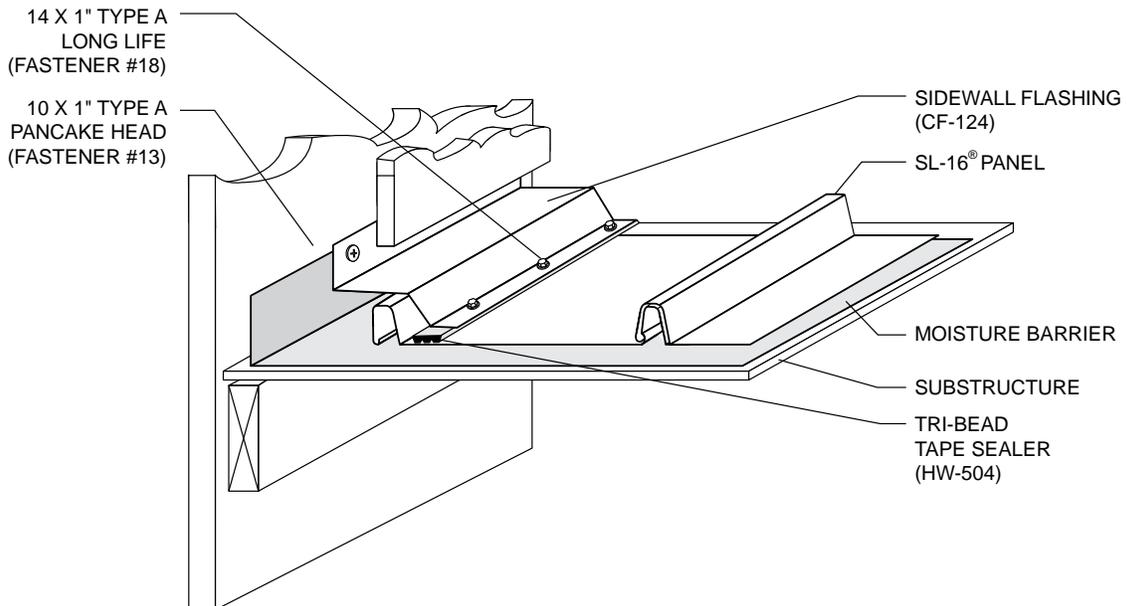

ISOMETRIC VIEW OF BEGINNING ON MODULE

NOTES:

1. If roof finishes on module, proceed to Step 2. If roof finishes off module, field bend a 1" leg up on panel before proceeding to Step 2.
2. Install Sidewall Flashing to roof panels with 14 X 1" Type A Long Life Fasteners at 1'-0" O.C. Fasteners must go through tri-bead tape sealer. Top leg of flash may be fastened to substrate as needed to hold in place before siding is installed.

DETAILS

ENDWALL

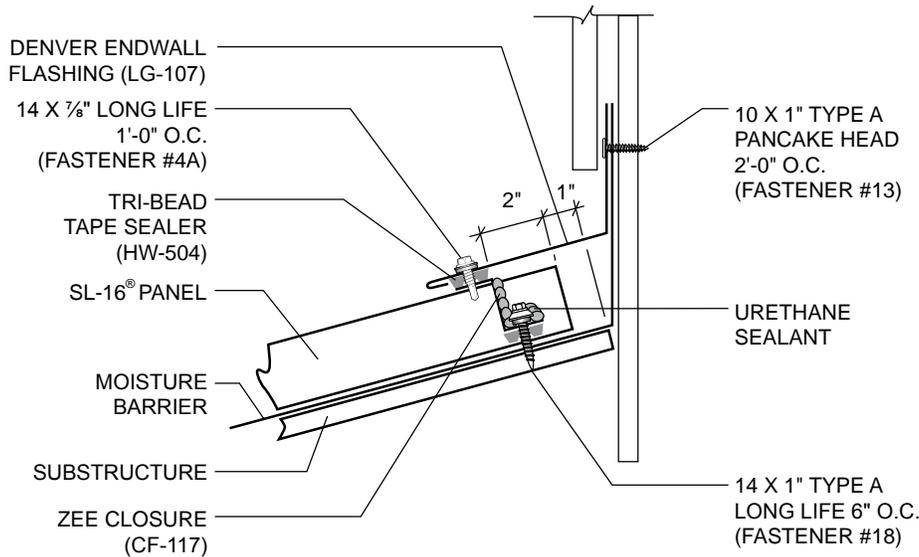

CROSS SECTION OF ENDWALL

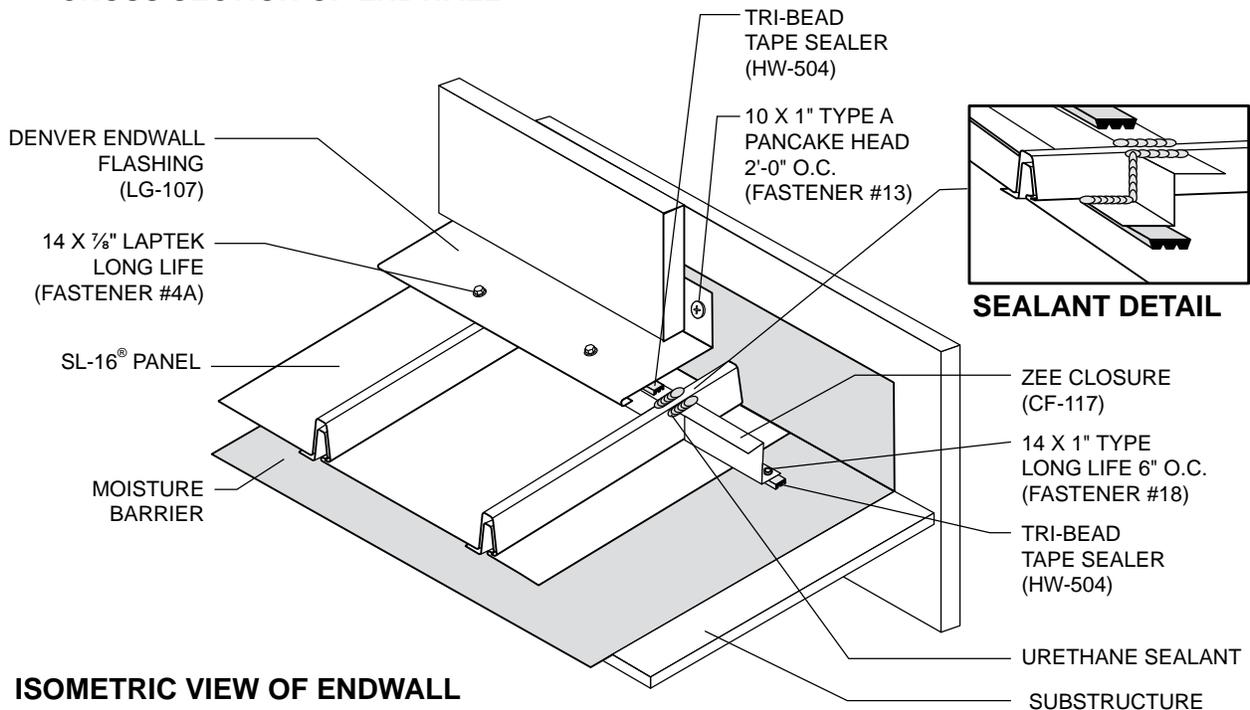

ISOMETRIC VIEW OF ENDWALL

NOTES:

1. Field cut Zee closures to fit panel width.
2. Install tri-bead tape sealer to bottom leg of Zee closures and attach to panels with four 14 X 1" Type A fasteners per panel (three fasteners for 12" panel). Vertical leg of Zee closure should be 3" from top of roof deck.
3. Seal ends of Zee closures with urethane sealant.
4. Attach endwall flash to Zee closures with 14 X 7/8" Long Life Laptek at 1'-0" O.C. Top leg of flash may be fastened to substructure as needed to hold in place before siding is installed.

DETAILS

RIDGE

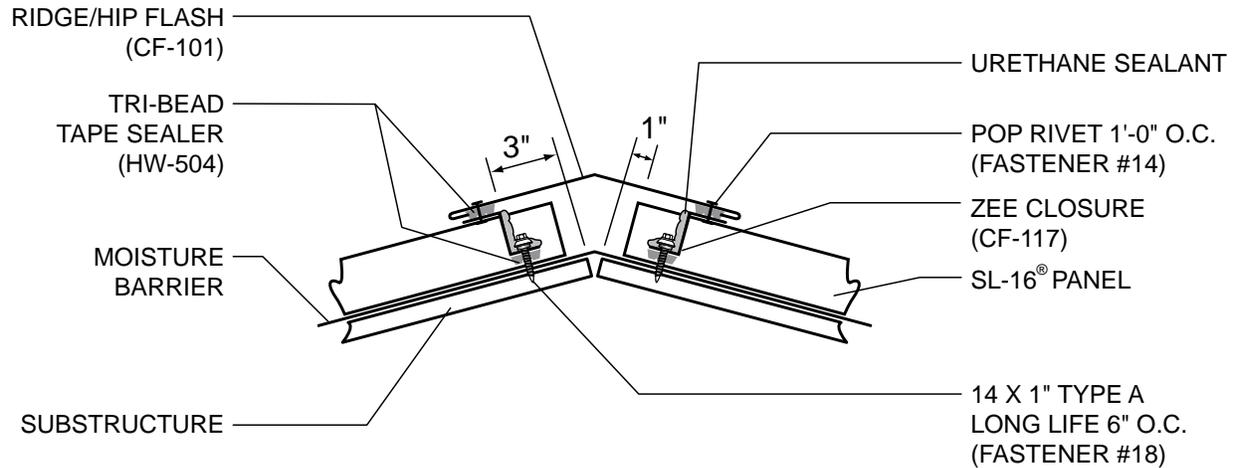

CROSS SECTION OF RIDGE

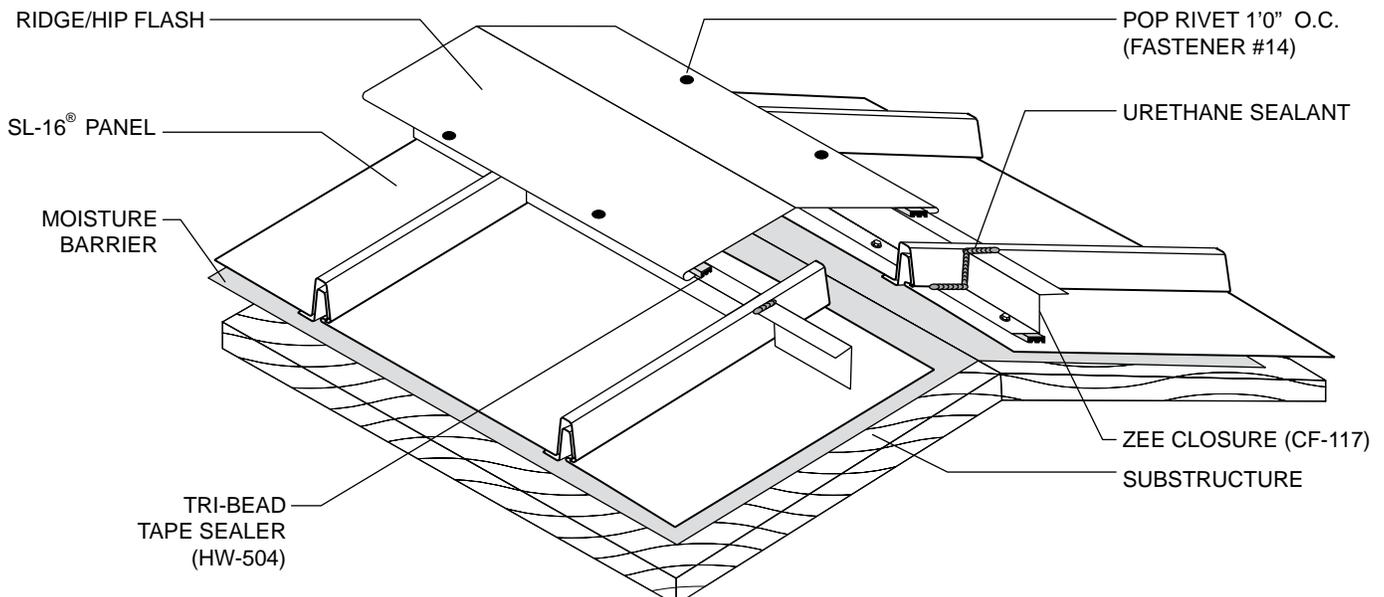

ISOMETRIC VIEW OF RIDGE

NOTES:

1. Field cut Zee closures to fit panel width.
2. Install tri-bead tape sealer to bottom leg of Zee closures and attach to panels with four 14 X 1" Type A fasteners per panel (three fasteners for 12" panel). Vertical leg of Zee closure should be 3" from center of ridge.
3. Seal ends of Zee closures with urethane sealant.
4. Attach ridge flash to Zee closures with pop rivets at 1'-0" O.C.

DETAILS

HIP

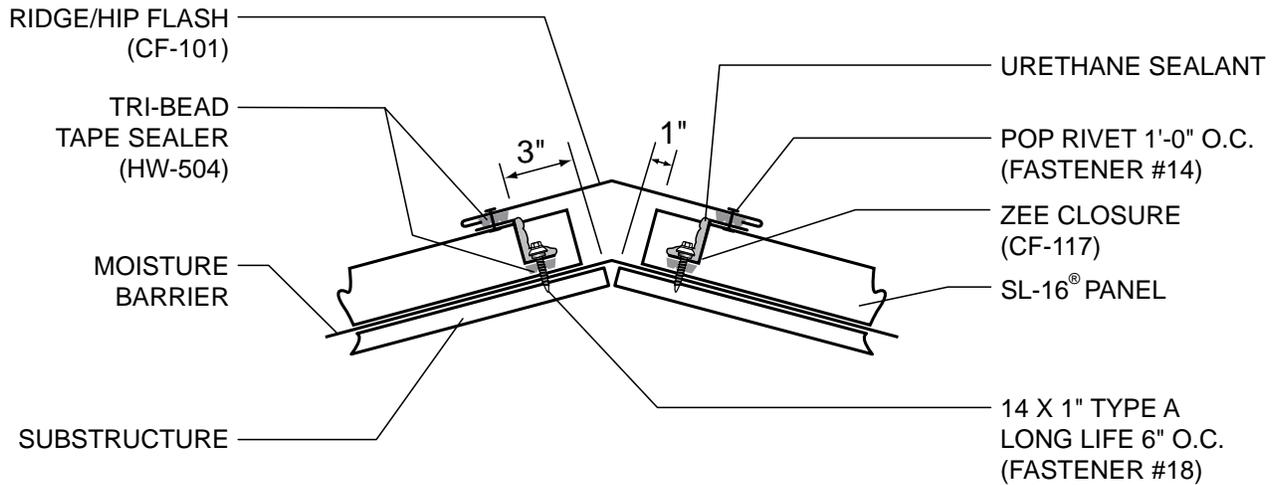

CROSS SECTION OF HIP

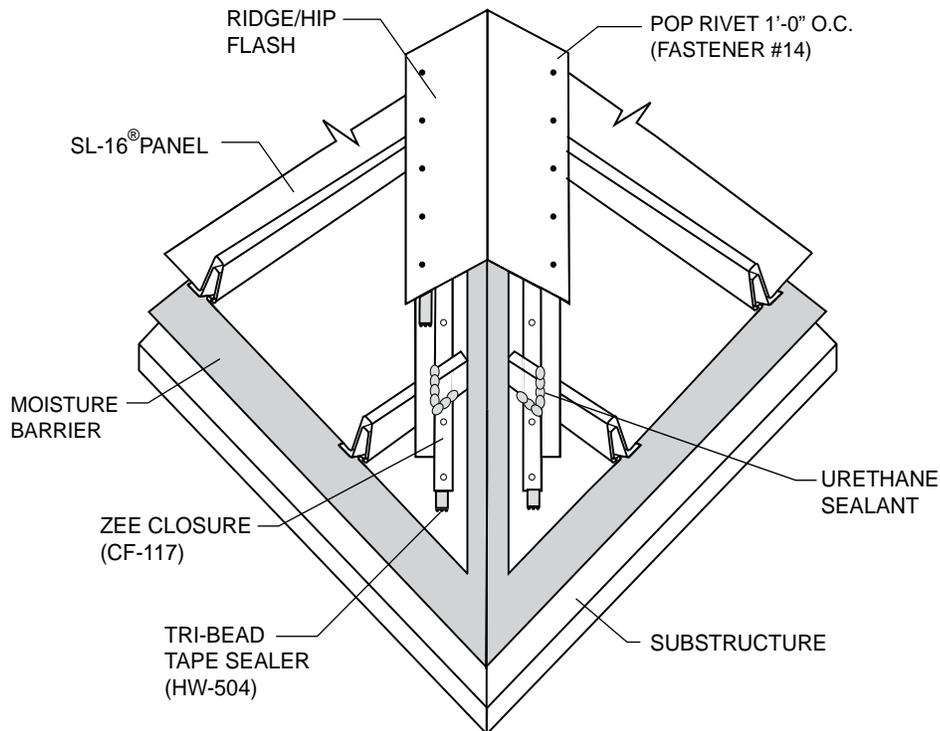

ISOMETRIC VIEW OF HIP

NOTES:

1. Bevel cut and install panels to follow angle of hip.
2. Field cut Zee closures to fit panel bevel width.
3. Install tri-bead tape sealer to bottom leg of Zee closures and attach to panels with 14 X 1" Type A fasteners 6" O.C. maximum. Vertical leg of Zee closure should be 3" from center of hip.
4. Seal ends of Zee closures with urethane sealant.
5. Attach Hip Flash to Zee closures with pop rivets 1'-0" O.C.

DETAILS

PEAK TRIM

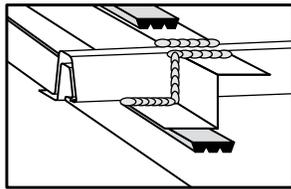
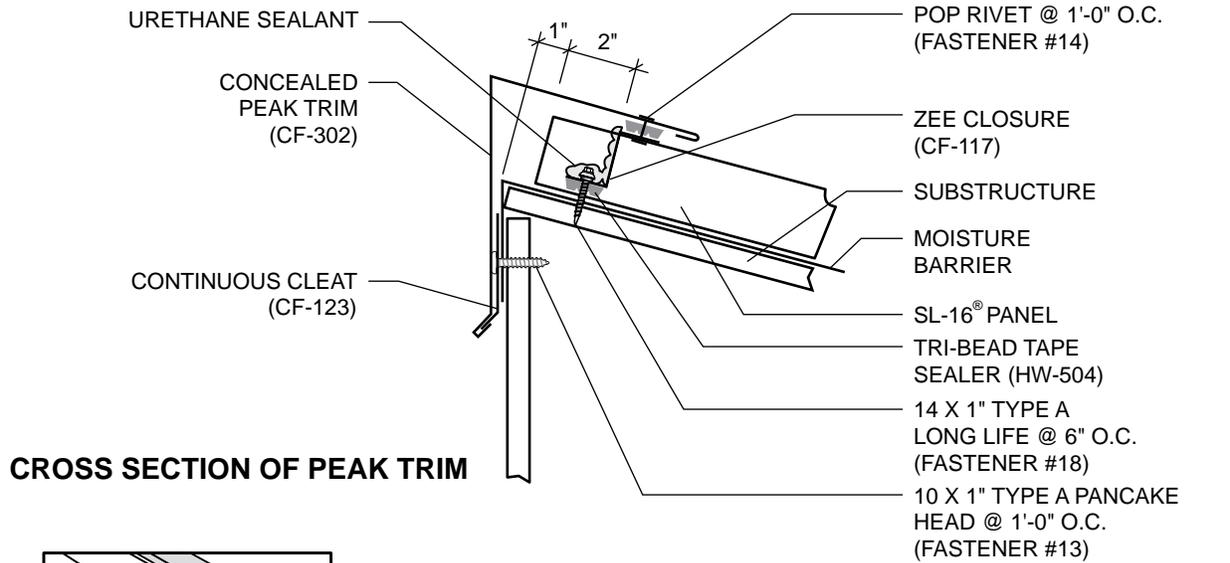

SEALANT DETAIL

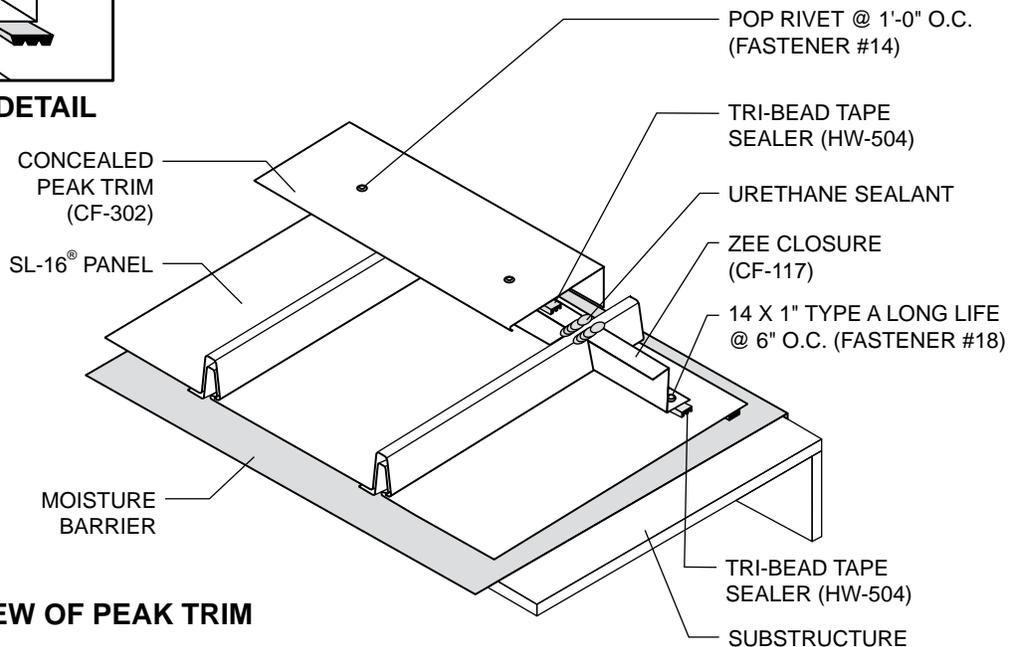

NOTES:

1. Field cut Zee closures to fit panel width.
2. Install tri-bead tape sealer to bottom leg of Zee closures and attach to panels with four 14 X 1" Type A fasteners per panel (three fasteners for 12" panel). Vertical leg of Zee closure should be 3" from edge of peak.
3. Seal ends of Zee closures with urethane sealant.
4. Install continuous cleat to wall with 10x1" pancake head screws at panel ribs.
5. Hook open item of concealed peak trim onto continuous cleat and attach top leg of trim to Zee closures with pop rivets at 1'-0" O.C.

DETAILS

FIELD HEMMING PANEL END

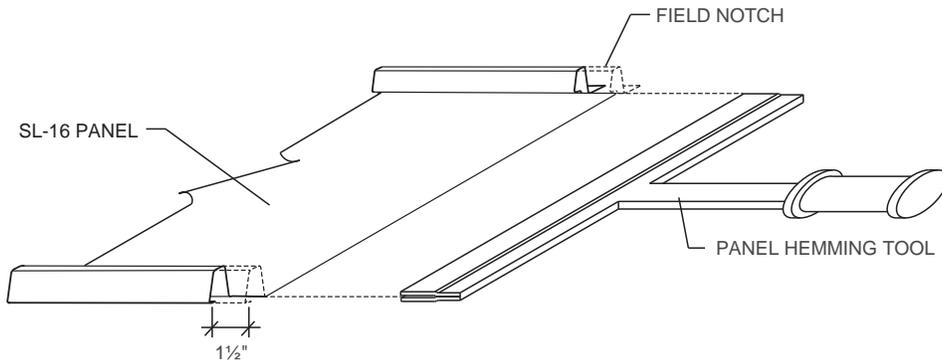

NOTCHING PANEL END

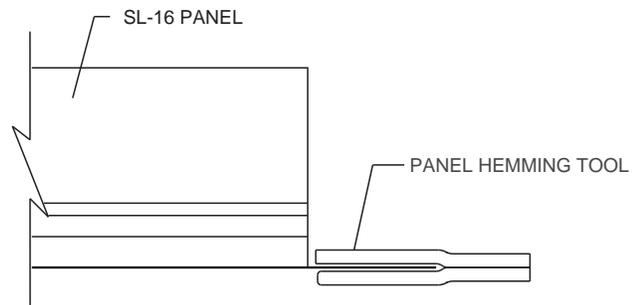

ENGAGING HEMMING TOOL

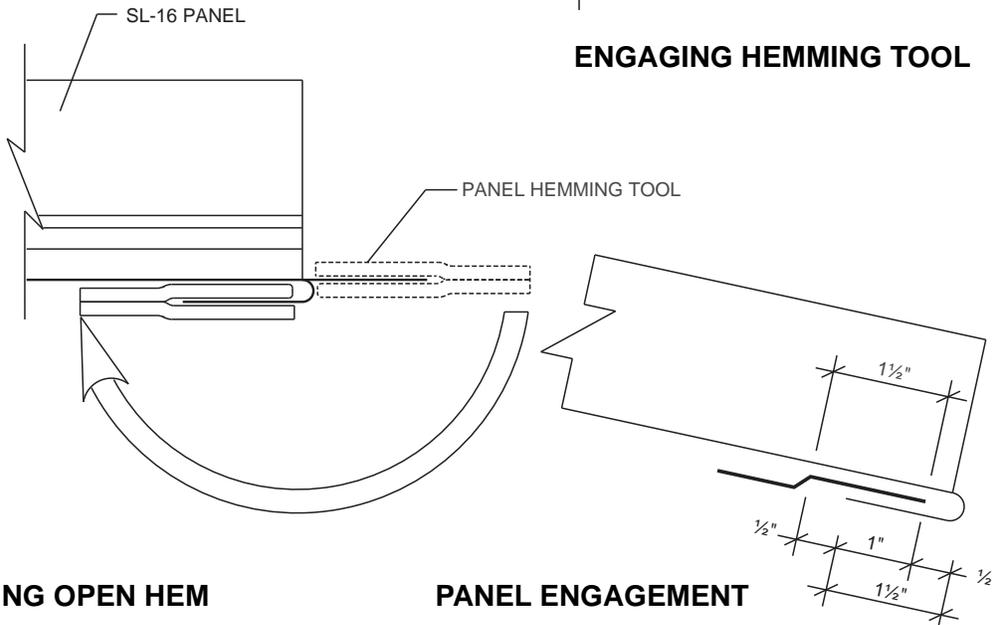

FORMING OPEN HEM

PANEL ENGAGEMENT

NOTES:

1. Field notch male and female legs of panel 1 1/2".
2. Engage panel hemming tool onto protruding panel.
3. Bend panel down to form an open hem.
4. Hem may be tightened with a pair of vise grip "duck bills."
5. Panels with minor ribs cannot be hemmed.

DETAILS

VALLEY WITH OFFSET CLEAT

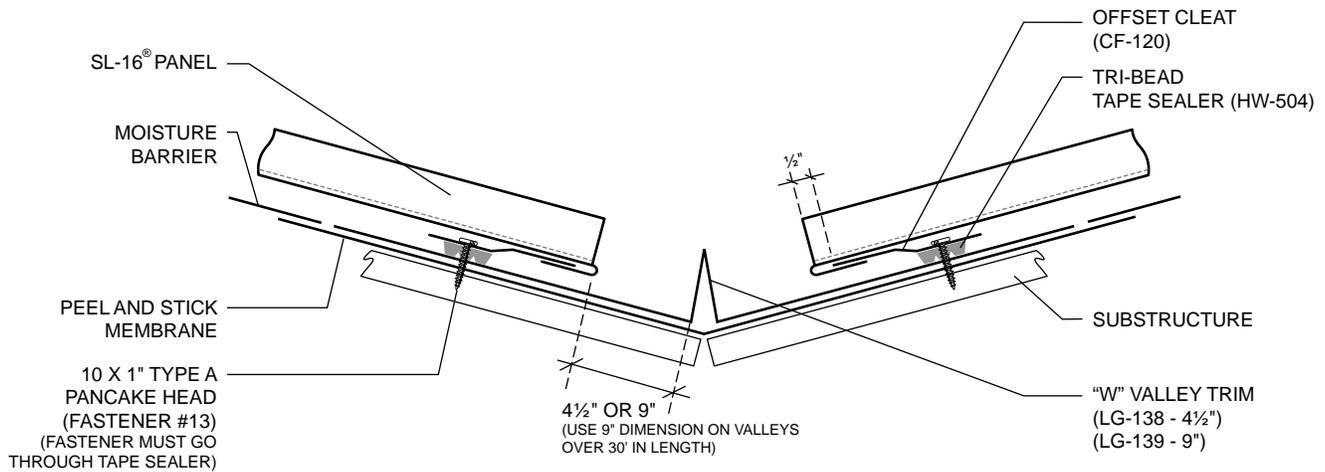

CROSS SECTION OF VALLEY

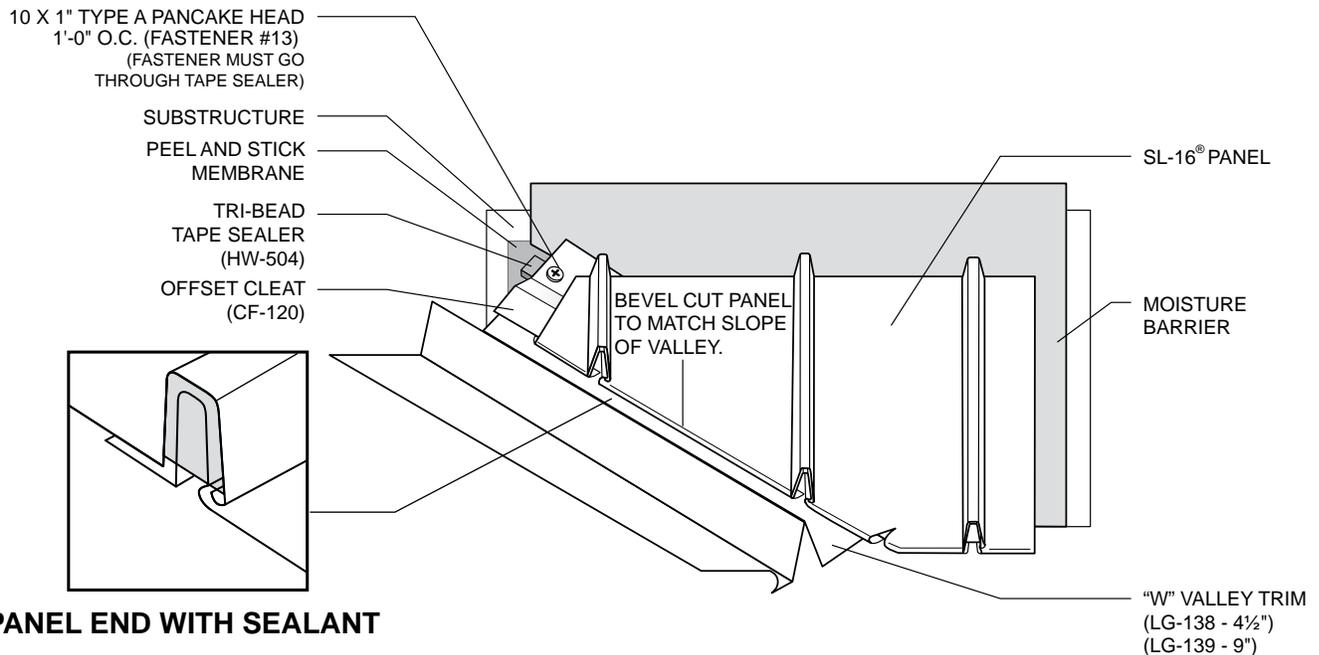

PANEL END WITH SEALANT

ISOMETRIC VIEW OF ALTERNATE VALLEY

NOTES:

1. Offset cleat is installed continuous along slope of valley over tri-bead tape sealer with 10 X 1" Type A Pancake Head Fastener at 1'-0" O.C. **Fasteners must go through tape sealer.**
2. Add ½" to panel length for the panel hem. See page S34 for Hemming Detail.
3. Fill ends of panels with urethane sealant.

DETAILS

EAVE WITH OFFSET CLEAT

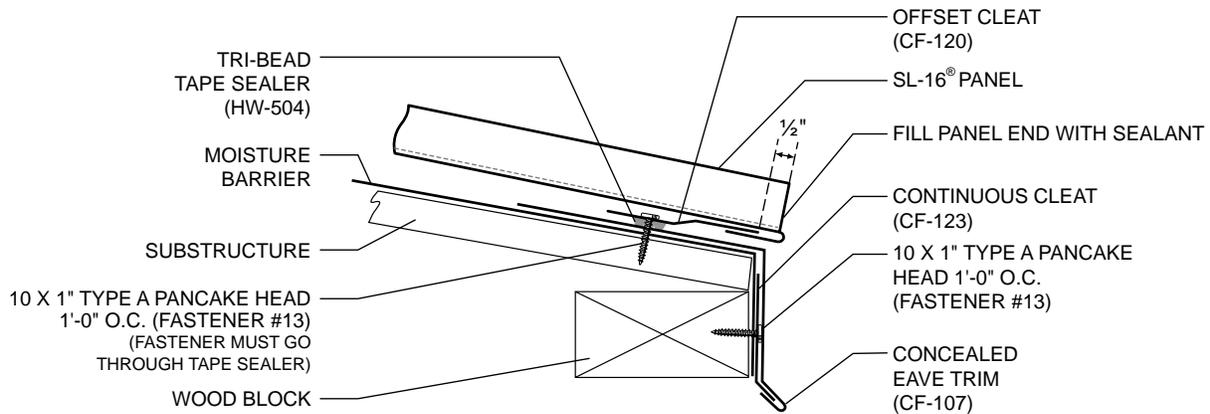

CROSS SECTION OF EAVE WITH OFFSET CLEAT

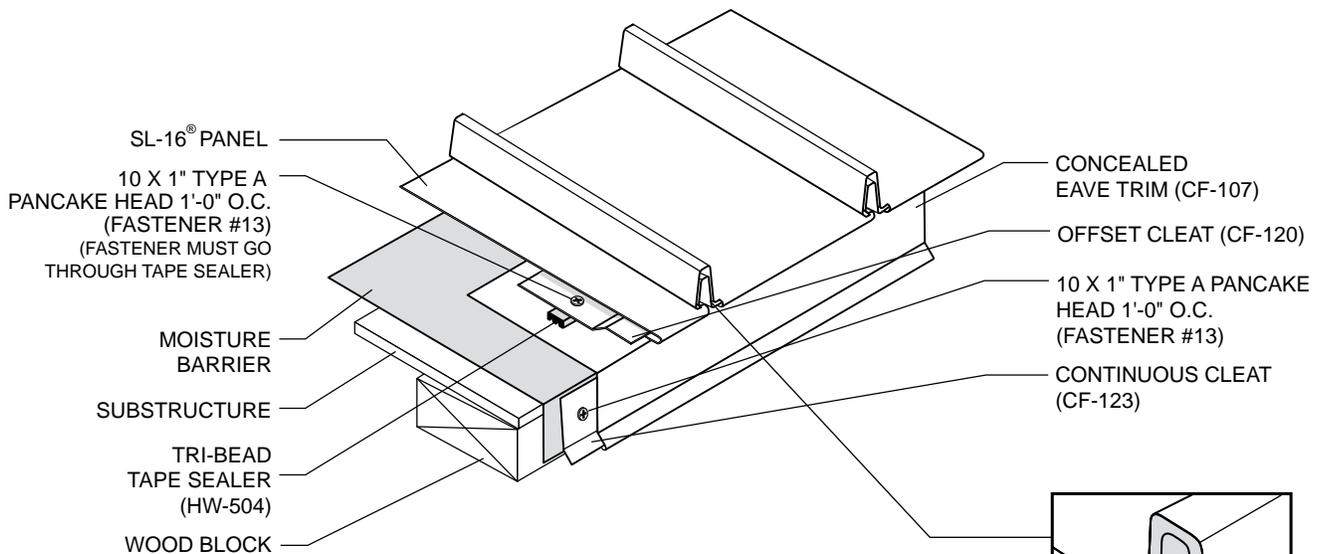

ISOMETRIC VIEW OF ALTERNATE EAVE WITH OFFSET CLEAT

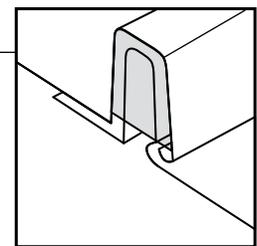

PANEL END WITH SEALANT

NOTES:

1. Where load conditions permit, install first panel fastener 12" from eave for best appearance. Consult a design professional or engineer to ensure compliance with local load and code requirements.
2. Attach offset cleat to substructure with 10 X 1" Type A Pancake Head Fastener at 1'-0" O.C.
3. Add 1½" to panel length for the panel hem. See Page S34 for Hemming Detail.
4. Fill ends of panels with urethane sealant.

DETAILS

EAVE TRIM WITH DRIP EDGE

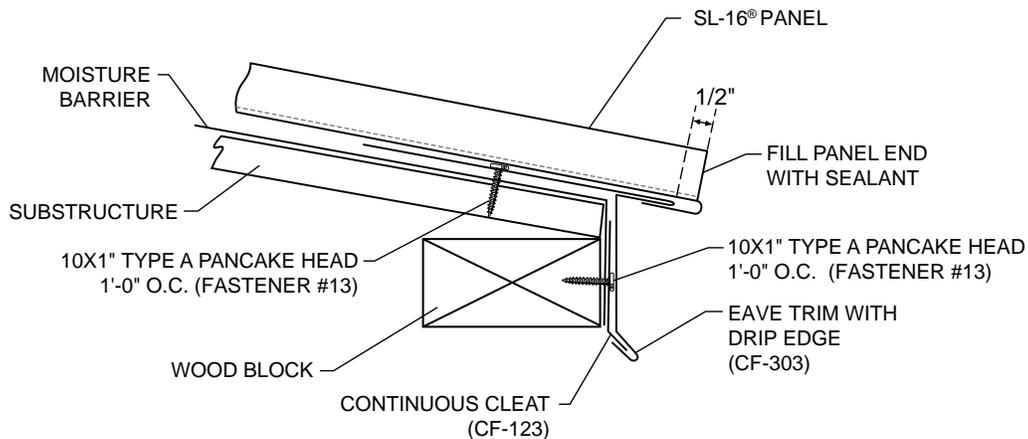

CROSS SECTION OF EAVE TRIM WITH DRIP EDGE

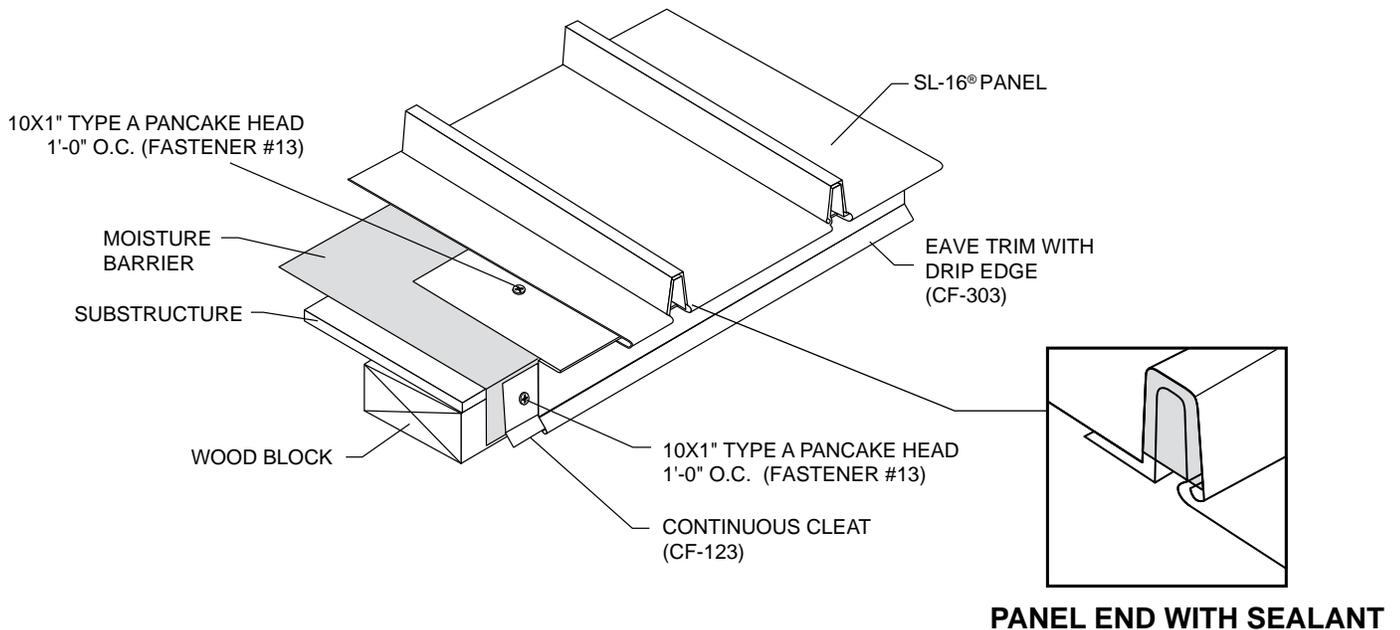

ISOMETRIC VIEW OF EAVE TRIM WITH DRIP EDGE

NOTES:

1. Where load conditions permit, install first panel fastener 12" from eave for best appearance. Consult a design professional or engineer to ensure compliance with local load and code requirements.
2. Attach offset cleat to substructure with 10 X 1" Type A Pancake Head Fastener at 1'-0" O.C.
3. Add 1/2" to panel length for the panel hem. See Page S34 for Hemming Detail.
4. Fill ends of panels with urethane sealant.

DETAILS

RAKE

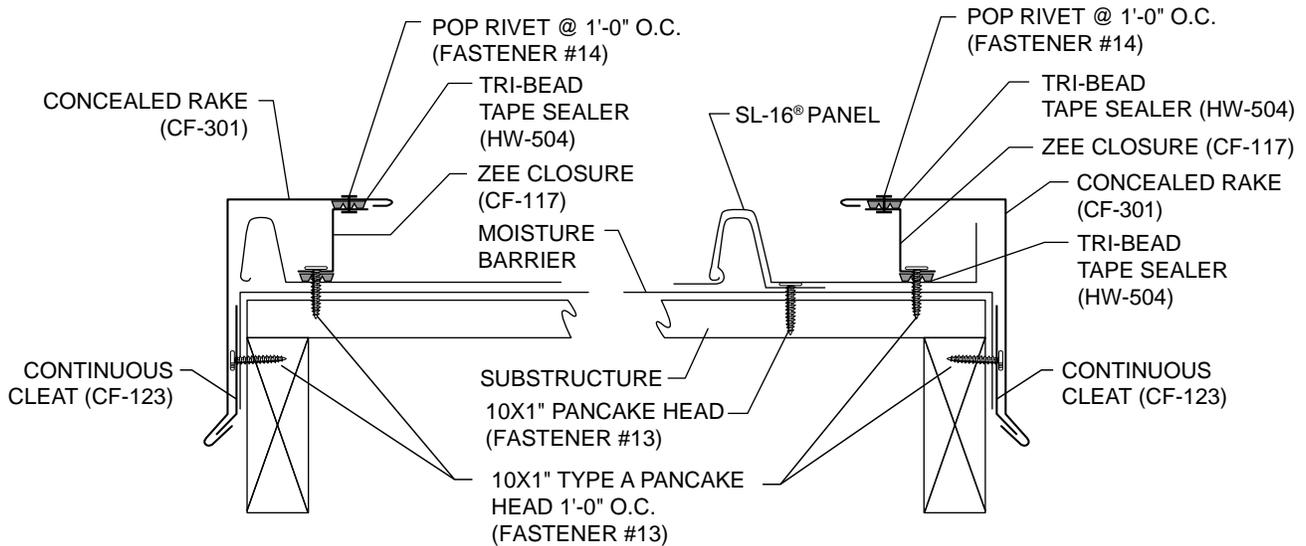

BEGINNING ON MODULE

FINISHING OFF MODULE

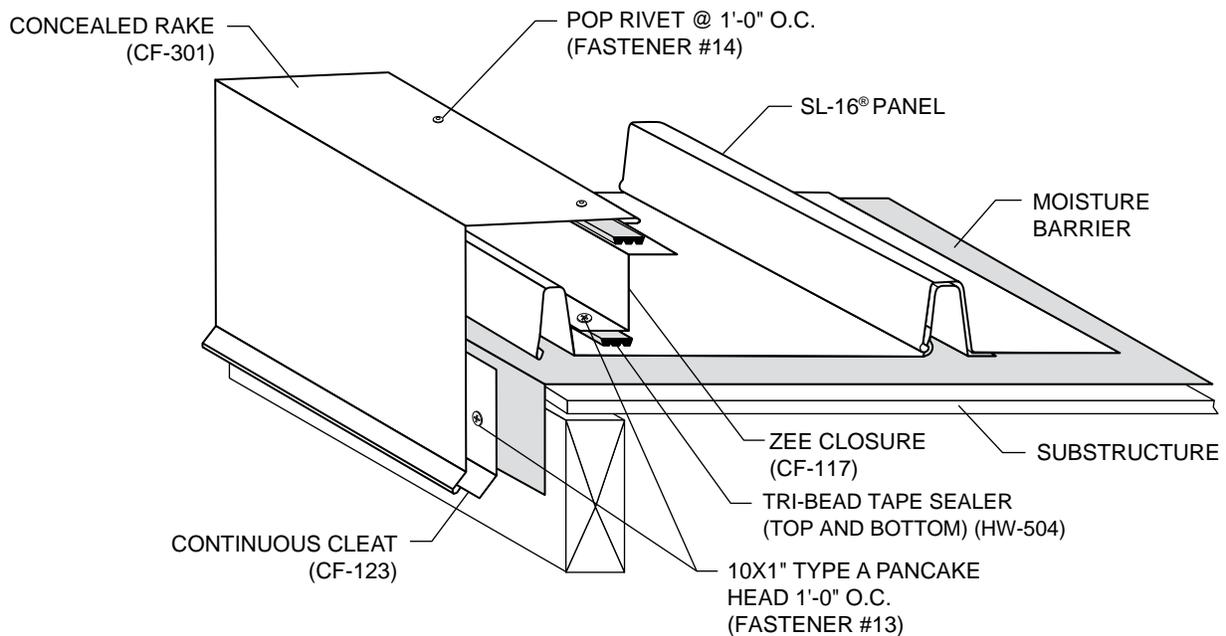

ISOMETRIC VIEW OF BEGINNING ON MODULE

NOTES:

1. Apply Tri-Bead Tape Sealer to bottom of Zee Closure and attach to substructure with 10x1" pancake head screws at 1'-0" on center.
2. Attach rake trim to Zee Closure with pop rivets at 1'-0" O.C.
3. When finishing off module, field bend a 1" leg up on panel before installing rake trim.

DETAILS

SIDE WALL

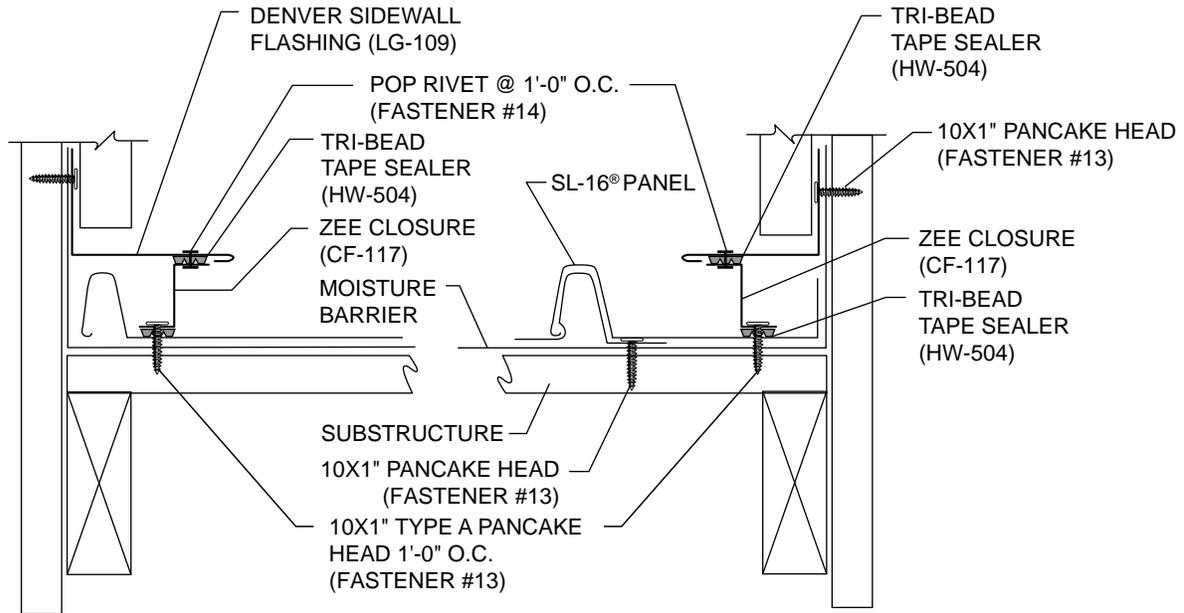

BEGINNING ON MODULE

FINISHING OFF MODULE

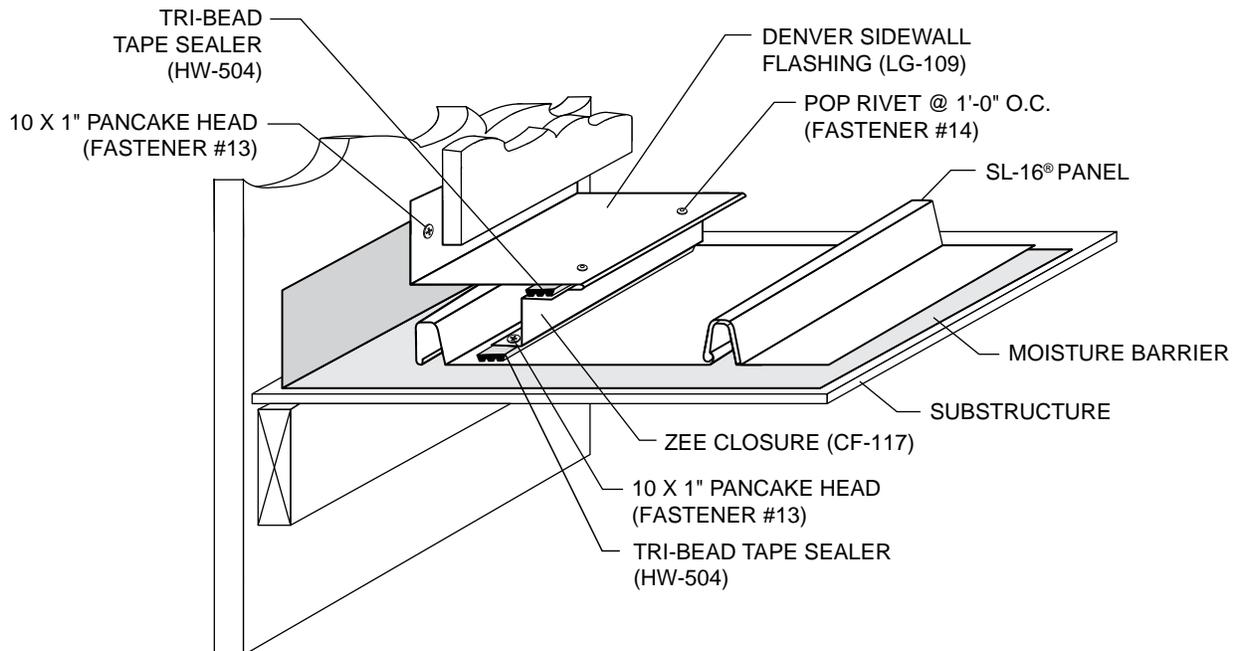

ISOMETRIC VIEW OF BEGINNING ON MODULE

NOTES:

1. Apply Tri-Bead Tape Sealer to bottom of Zee Closure and attach to substructure with 10x1" pancake head screws at 1'-0" on center.
2. Attach sidewall flashing to Zee Closure with pop rivets at 1'-0" O.C.
3. When finishing off module, field bend a 1" leg up on panel before installing sidewall flashing.

DETAILS

ENDWALL

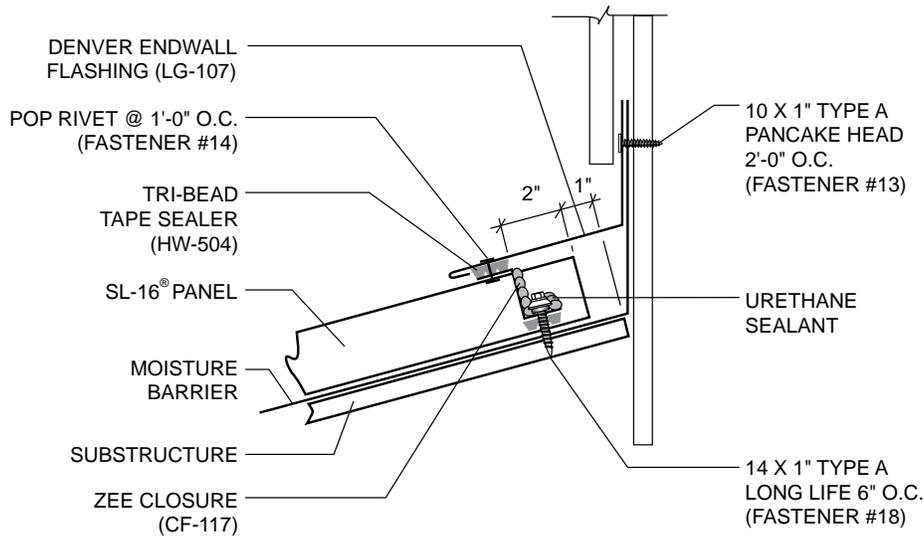

CROSS SECTION OF ENDWALL

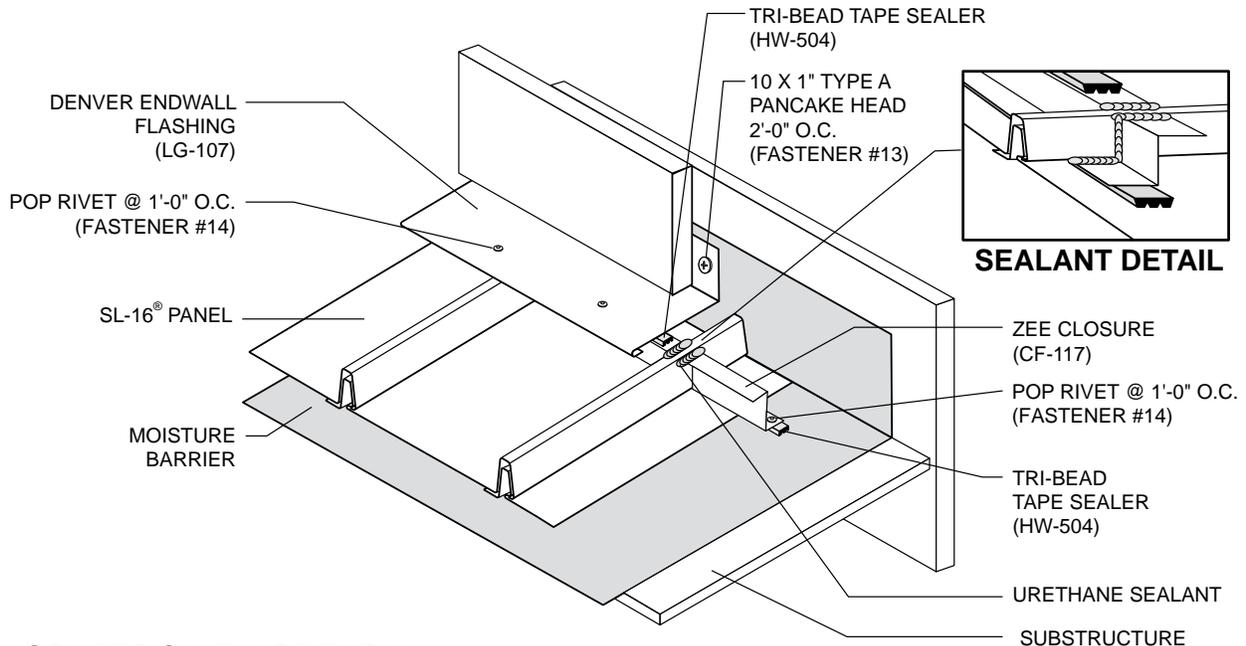

ISOMETRIC VIEW OF ENDWALL

NOTES:

1. Field cut Zee closures to fit panel width.
2. Install tri-bead tape sealer to bottom leg of Zee closures and attach to panels with four 14 X 1" Type A fasteners per panel (three fasteners for 12" panel). Vertical leg of Zee closure should be 3" from top of roof deck.
3. Seal ends of Zee closures with urethane sealant.
4. Attach endwall flash to Zee closures with pop rivets at 1'-0" O.C. Top leg of flash may be fastened to substructure as needed to hold in place before siding is installed.

DETAILS

ROOF TRANSITION

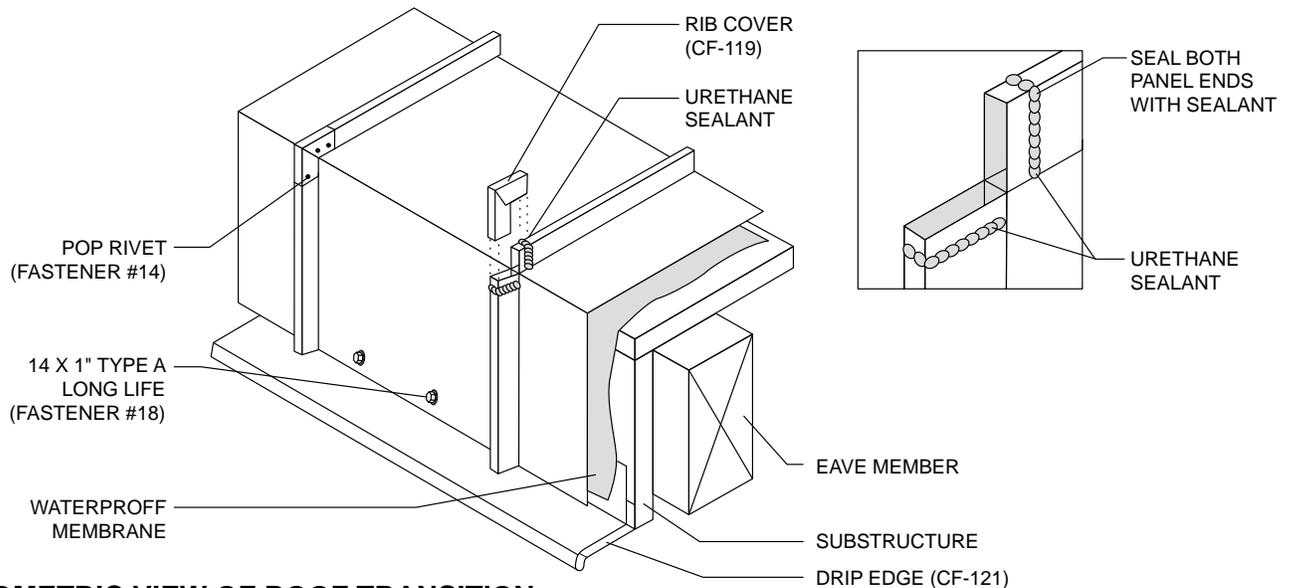
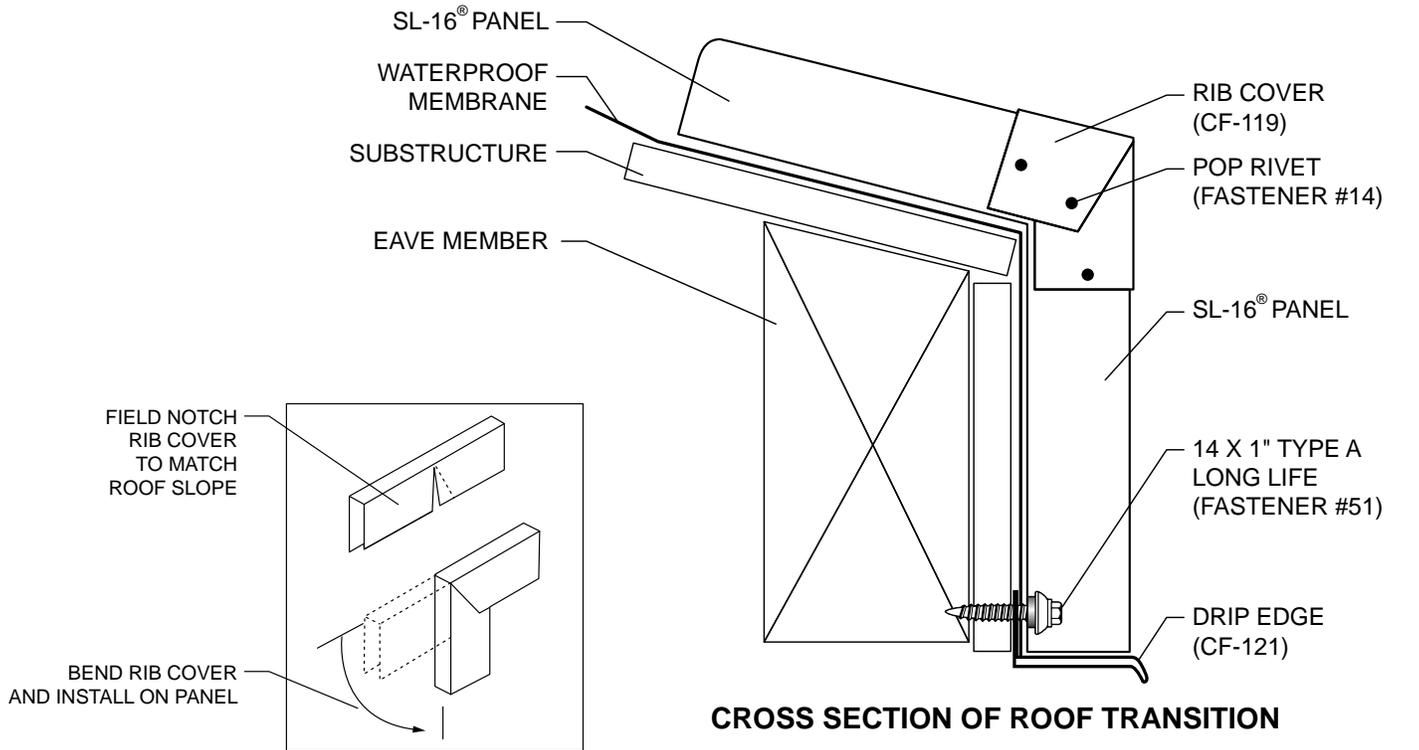

NOTES:

1. Lap Waterproof Membrane on outside of Drip Edge.
2. Field cut legs of panels and bend to required angle.
3. Fill both exposed ends of panels with urethane sealant.
4. Field notch rib cover to allow it to bend to the proper angle.
5. Field apply a bead of sealant over rib before applying rib cover.

DETAILS

SLOPE CHANGE - FIXED EAVE

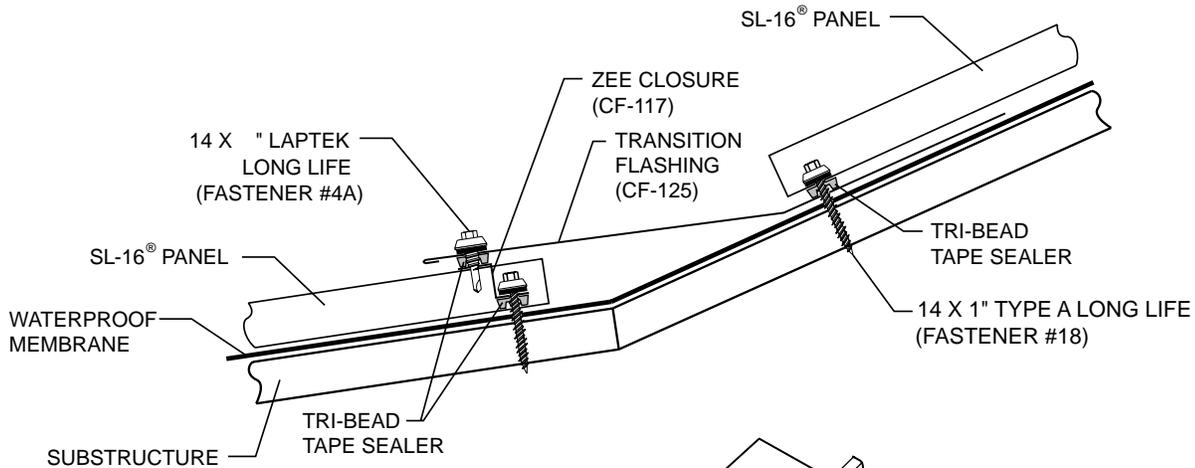

CROSS SECTION OF SLOPE CHANGE

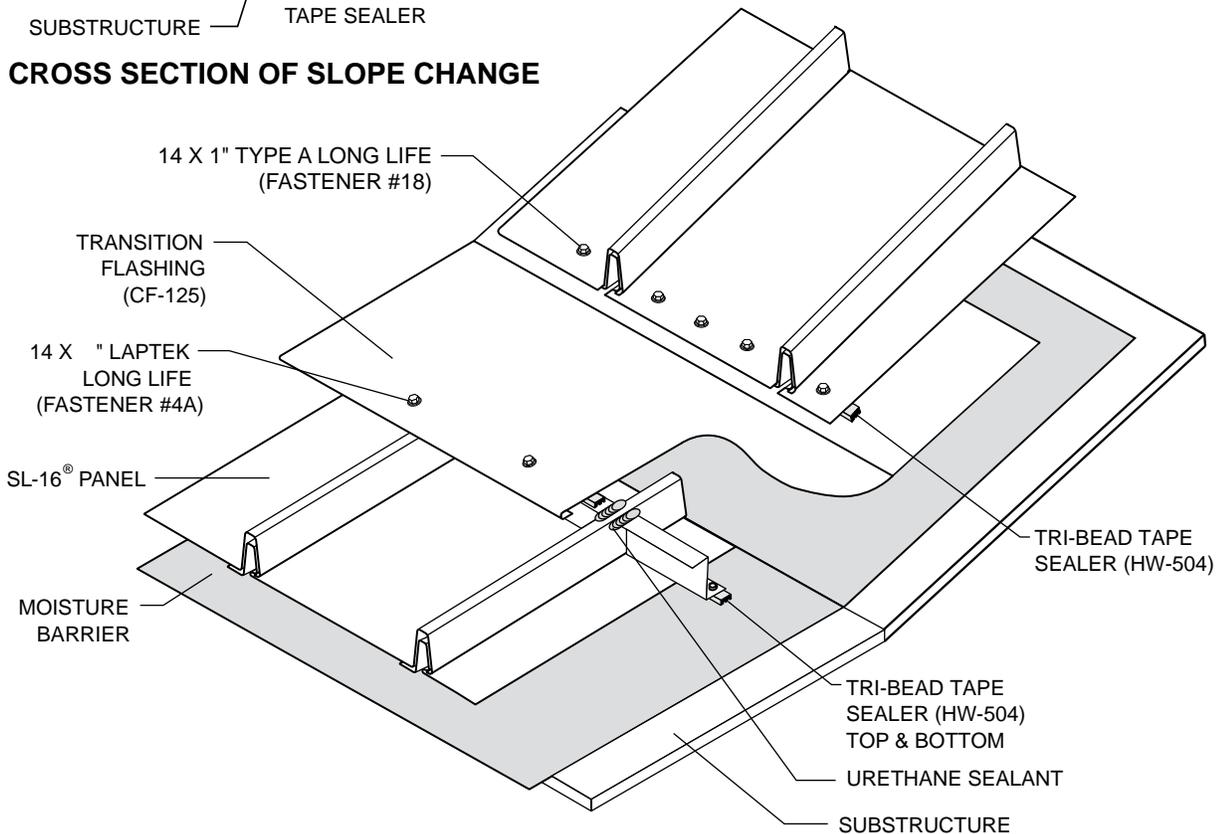

ISOMETRIC VIEW OF SLOPE CHANGE

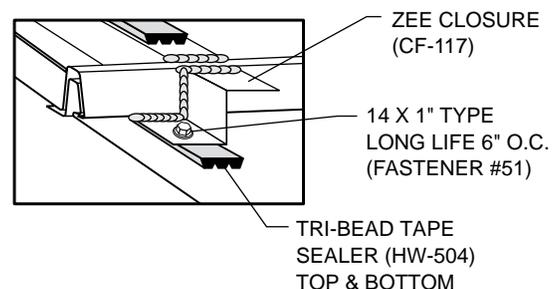

DETAILS

SLOPE CHANGE - FLOATING EAVE

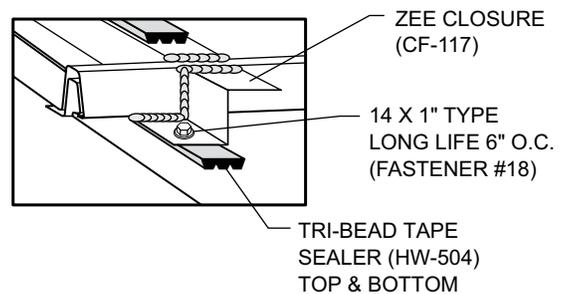
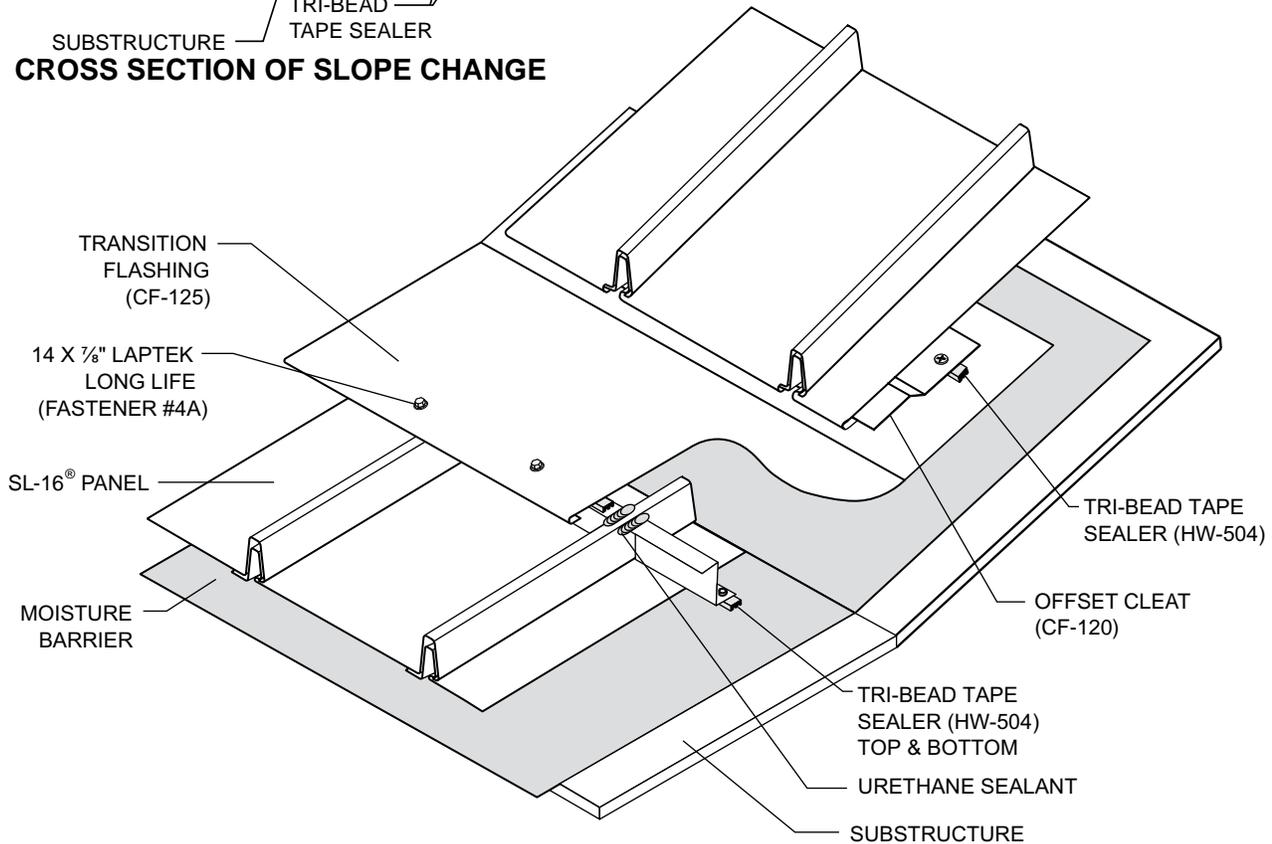
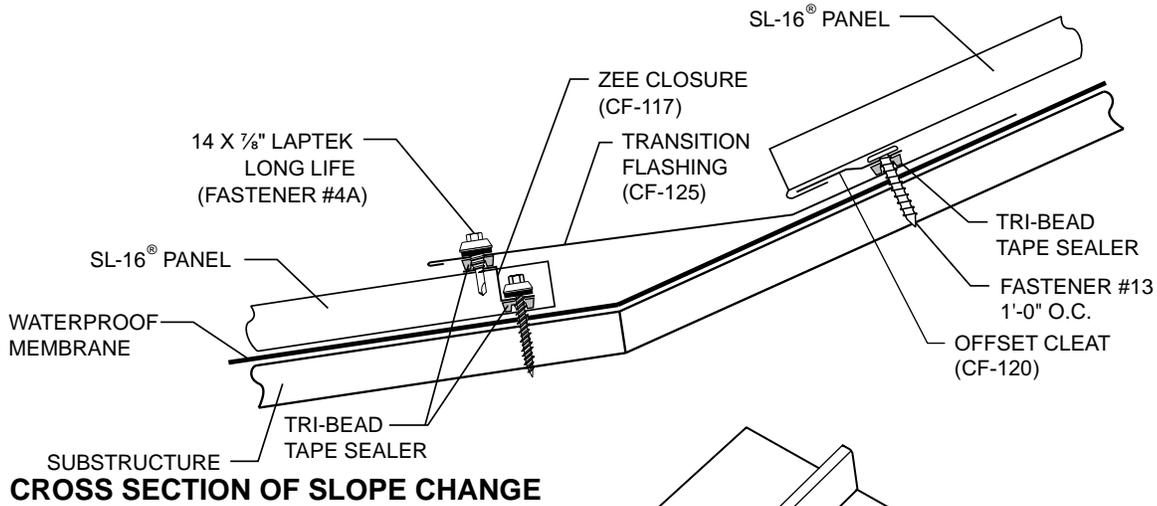

DETAILS

PROFILE VENT

1. Install your metal roofing panel according to manufacturer's instructions. Apply mastic above and below pre-drilled holes in the clip. Before installing ProfileVent, insert #14A screw through the large down-slope access hole in top of the Ridge Cap Anchor Clip.
2. Lift the back end of clip. Slip ProfileVent under the clip. Push clip back down and insert another #14A screw in the up-slope hole.
3. Screw through ridge cap and top of each anchor clip. Pop Rivets can be used to anchor the ridge cap when using architectural or standing seam panels.

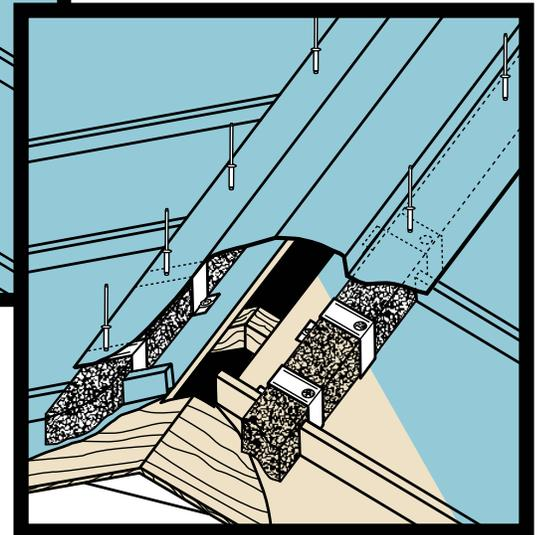
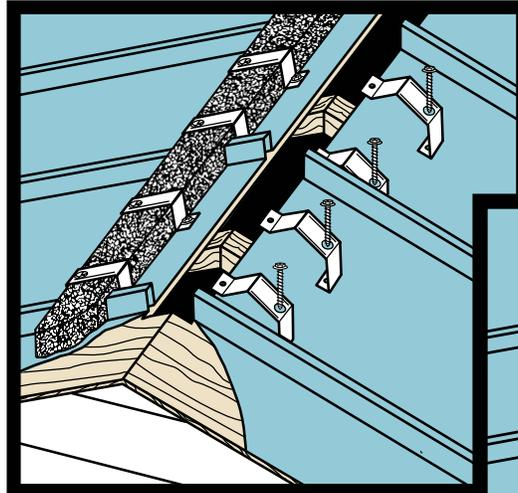

TECHNICAL DATA

Passed	Net Free Area	1" nom. thickness	8.5 sq. in. per lin. ft. per slope (17 sq. in. per lin. ft. ridge)
Passed	Air Permeability	ASTM D737	>>760 cu. ft. per minute
Passed	Self-ignition Temp.	ASTM D1929	963°F
Passed	Cold Crack	Loren C115	Resistance to >-25°F
Passed	Snow Infiltration	CRL 5704	-0-
Passed	Tear Strength	ASTM D1294-86	Tear: Machine 25 p.p.i. Counter 25 p.p.i.
Passed	Tensile Strength	ASTM D2261-83	Tear: Machine 25 p.p.i. Counter 25 p.p.i.
Passed	Attic Dust Test	ASTM D1739-98	No Clogging, will not hold dust
Passed	Dust Exposure Test	ICBO AC132	
Passed	Loren	Compression	13%
		Recovery	100%
Passed	UV Stable	Chamber Test	No change to cover or materials
Passed	Abrasion Test	ASTM D1175	No damage to panel surface
Passed	100 MPH Wind Driven Rain Test		

NOTE 1: When ordering profile vent for panels that are striated use HW-116SL12 for SL-12® or HW-116SL16 for SL 16®

NOTE 2: Use appropriate length fasteners to affix Ridge Cap through Profile Vent into Deck. Use Tri-Bead Tape Sealer at Profile Vent/Deck interface. DO NOT USE POP RIVETS.

TERMS AND CONDITIONS OF SALE

1. Parties - All references to "ABC" or "Seller" refer to American Building Components, an unincorporated division of NCI Group, Inc. ABC and Buyer may sometimes collectively be referred to herein as the "parties."
2. Binding Effect - The following terms and conditions (the "Terms and Conditions") shall apply to any and all sales between ABC and the Buyer and shall not be waived, modified or amended without the express written consent of the ABC's President or Executive Vice-President. Any and all terms and/or conditions contained within any other purchase order, agreement or other document(s) issued by Buyer, whether conflicting with these Terms and Conditions hereto or not, shall be deemed null, void and of no force, effect or consequence. Any and all sales by ABC of any nature to Buyer shall be made under the provisions of this Agreement. Any document(s) that Buyer may use for its convenience including, but not limited to, purchase orders or sales acknowledgement forms shall be deemed to be for the administrative convenience of Buyer only, and this Agreement as well as the terms and conditions as stated in ABC's invoices and bills of lading shall supersede and take precedence over any of Buyer's terms and conditions which may be contained on any such forms. Further, should ABC act upon this Agreement without first obtaining Buyer's signature on a Purchase Order, Buyer hereby irrevocably agrees to be bound by this Agreement to the exclusion of any contrary terms and conditions proposed by Buyer. All orders are subject to final approval and written acceptance by ABC.
3. Payments - Payments due ABC under the terms of this sale and any other money due ABC by Buyer shall be paid to ABC at its Houston, Harris County, Texas office. Unless otherwise agreed in advance and in writing by ABC's Credit Department, payment for the materials and/or services under this Agreement shall be COD. Any and all different credit terms must be pre-approved in writing by ABC's Credit Department. If ABC grants Buyer credit terms, invoices paid ABC by Buyer within ten (10) days of date of invoice may, in ABC's sole discretion and judgment, be allowed ½% discount, net due thirty (30) days from date of invoice. C.O.D. shipments paid at the time of shipment are not allowed any discount. In the event ABC grants Buyer credit terms, said credit terms are subject to change at any time, for any reason, at the sole discretion of ABC without prior written notice to Buyer. Unless specifically enumerated herein, the price does not include any taxes (including excise, privilege, occupation, use, sales, etc.; Federal, State or local) or costs of shipment. All materials sold hereunder are sold F.O.B. ABC's plants. ABC reserves the right to approve or disapprove the carrier on any and all C.O.D. shipments.
4. Lien/Release - Buyer agrees that all payments with lien release language on the back of any check or other legal tender shall be sent only to ABC at its Houston, Harris County, Texas office. Buyer agrees that any payment(s) accepted through ABC's lock box with lien release language on the check does not bind ABC to the attempted release. ABC's agent(s) at the lock box who endorses and/or accepts checks for ABC is authorized only to accept unconditional payments, and no action by such agent(s) shall ever give rise to a claim of any alleged authority, apparent or otherwise, beyond that described in this paragraph. Acceptance of any conditional check, including any lien release language or otherwise at the lock box shall only be a partial release for those funds received, and never otherwise. This paragraph cannot be waived or modified except in writing in advance by the President of ABC.
5. Interest/Costs of Collection - Any and all payment(s) deferred after the due date as specified shall bear interest at the greater of the rate of ten percent (10%) per annum or a rate equal to the maximum non-usurious rate under applicable law. If an invoice becomes past due, is placed in the hands of an attorney for collection, if collected by any legal proceeding(s), or if this Agreement is relevant to any other dispute(s) between the parties, in addition to any other amount(s) and damage(s) recovered by ABC, Buyer agrees to pay ABC any and all attorneys' fees and costs incurred in any such dispute(s) and/or proceeding(s), together with interest, expenses, costs and any other charges, which attorneys' fees shall not be less than thirty percent (30%) of the total amount payable. "Costs incurred in the collection of sums" as used herein is not to be limited to costs incurred in litigation, but includes, without limitation, copying and mailing expenses, lien fees, lost management time, inspection expenses and expert witnesses expenses in addition to taxable costs incurred in litigation.
6. Security Interest - Buyer has and does by these presents grant to ABC and ABC has and does hereby retain a security interest in all materials, parts and accessories (as well as all finished goods and/or the proceeds from the sale thereof) described in and being purchased by Buyer pursuant to this Agreement. In addition, Buyer has and does by these presents grant to ABC and ABC has and does hereby retain a security interest in all existing or subsequently arising accounts, accounts receivable and supporting obligations which may from time to time hereafter come into existence during the term of this security interest as a result of Buyer's sale of any of the said materials, parts, accessories or finished goods thereof to any third party. The security interest herein granted by Buyer and retained by ABC is to secure payment of the full purchase price and all other charges due and owing ABC by Buyer under the terms of this sale. This Agreement is governed by Section 2.101, et. seq. of the Texas Business & Commerce Code, and the security interest hereunder constitutes a "purchase money security interest" pursuant to the Uniform Commercial Code. This instrument is a contract, security agreement and financing statement between the parties hereto.
7. Authorization for Credit History - The Buyer or undersigned individual, who is either the credit applicant or a principal/agent of the Buyer, recognizes that a credit history report may be a factor in the evaluation of the credit history of the Buyer. Buyer, therefore, irrevocably consents to and authorizes the use of a commercial, consumer or any other credit report on or pertaining to the Buyer or undersigned individual(s) by ABC or its agents from time to time as may be needed in the credit evaluation process.
8. Setoff/Recoupment - In addition to any right of setoff or recoupment permitted by law, ABC shall have the right at any time to setoff or recoup any amount due and owing from Buyer to ABC or any of ABC's subsidiaries, divisions, or affiliates against any amount due and owing from ABC or any of its affiliates, divisions, or subsidiaries to Buyer.
9. Buyer Responsible for Accuracy of Order/Delivery - Buyer hereby assumes sole and complete responsibility for the accuracy of any and all verbal orders unless written confirmation is received prior to fabrication. Confirming orders should be marked "Confirming Order-Do Not Duplicate." Buyer may arrange for pickup of order(s) at ABC's plant or shipment will be made by common carrier - "Freight Collect" - unless other arrangements are previously made and agreed to by the parties in writing.
10. Cancellation - In the event of cancellation, Buyer agrees to pay ABC for any and all fees, expenses, costs and damages occasioned by the cancellation hereof.
11. Manufacturer's Warranties/Disclaimers - Upon receipt of payment in full, ABC warrants its workmanship only against failure due to defective material or workmanship for a period of one (1) year from date of manufacture. In any event, however, Buyer's sole and exclusive remedy shall be limited to, in ABC's sole discretion and judgment, the replacement of defective part(s), F.O.B. ABC's plant or repair of defective part(s). Transportation, redesign, dismantling, disposal of material and installation are not included and shall be borne and paid for by Buyer. Any such replacement or repair shall not include any materials not sold by ABC hereunder, and specifically excludes any obligation by ABC related to other property of the Buyer or any property of third parties. UNDER NO CIRCUMSTANCES SHALL ABC BE RESPONSIBLE FOR OR LIABLE TO BUYER, OWNER(S) OR ANY OTHER THIRD PARTY, IN ANY RESPECT FOR, AND ABC HEREBY EXPRESSLY DISCLAIMS ANY AND ALL WARRANTIES OR REPRESENTATIONS PERTAINING TO, PRESENT OR FUTURE WATER LEAKS OR MOISTURE INTRUSION(S), DAMAGE(S) TO THE BUILDING(S), OR ANY COMPONENTS OR CONTENTS THEREOF, OR ANY INTERIOR SPACE(S) OR PROPERTY THEREIN, INCLUDING CLAIMS PERTAINING TO MOLD, MILDEW OR FUNGI, OR INTERRUPTION IN THE USE OF THE BUILDING(S) OR PERSONAL INJURY OR PROPERTY DAMAGE CLAIMS RESULTING FROM THE ALLEGED EXISTENCE OR GROWTH OF MOLD, MILDEW AND/OR FUNGI. As a condition precedent to the effectiveness of any warranty coverage provided herein, all amounts due and owing to ABC under this or any other agreement with ABC or ABC's affiliates, whether disputed or not by Buyer, must be fully paid. ABC'S SOLE LIABILITY, IF ANY, TO BUYER SHALL BE STRICTLY LIMITED TO THE WRITTEN EXPRESS WARRANTIES SPECIFIED HEREIN, AND BUYER AGREES AND STIPULATES THAT ABC SHALL NOT BE LIABLE FOR ANY INCIDENTAL, CONSEQUENTIAL, LIQUIDATED, EXEMPLARY OR PUNITIVE DAMAGES, WHICH BUYER MAY ALLEGEDLY SUFFER FOR ANY REASON, INCLUDING REASONS ATTRIBUTABLE TO ABC. ABC DOES NOT WARRANT ANY PRODUCTS OR MATERIALS THAT ARE NOT MANUFACTURED BY ABC EXCEPT TO THE EXTENT OF A WARRANTY THAT ABC MAY ACTUALLY PASS THROUGH OR ASSIGN FROM A MANUFACTURER. EXCEPT AS STATED ABOVE, ABC HEREBY EXPRESSLY DISCLAIMS ALL WARRANTIES, EXPRESS OR IMPLIED, INCLUDING, WITHOUT LIMITATION, ANY IMPLIED WARRANTIES OF MERCHANTABILITY OR FITNESS FOR A PARTICULAR PURPOSE, AND THE PARTIES HERETO HEREBY STIPULATE THAT ALL SUCH WARRANTIES ARE HEREBY DISCLAIMED. Buyer agrees and stipulates that in any action or claim brought by Buyer or any third party or in any action or claim brought against Buyer involving the provisions of this section, Buyer hereby waives any claim or defense that the above covenants are unenforceable, void or voidable, for any reason, including, but not limited to, fraud, misrepresentation, illegality, unenforceable restraint of trade, failure of consideration, illusory contract, mistake, or any other substantive legal defense. Buyer acknowledges, agrees and stipulates that oilcanning of materials shall not be a cause of rejection of materials. Claims for shortages or defective materials must be made to ABC in writing within five (5) days after delivery of shipment (which the Parties agree and stipulate is a reasonable time), or any and all such claim(s) shall be conclusively waived and released by Buyer. Notwithstanding the foregoing, installation of materials shall unequivocally constitute irrevocable acceptance of said materials. FOR COMPLETE PERFORMANCE SPECIFICATIONS, PRODUCT LIMITATIONS AND DISCLAIMERS, PLEASE CONSULT ABC'S PAINT AND GALVALUME PLUS WARRANTIES. UPON RECEIPT OF PAYMENT IN FULL, THESE WARRANTIES ARE AVAILABLE UPON REQUEST FOR ALL PAINTED OR GALVALUME PLUS, PRIME PRODUCTS. Sample copies can be found at www.abcmetalroofing.com or contact your local ABC Sales Representative.
12. No Incidental, Special or Consequential Damages - Notwithstanding any other agreement to the contrary, Buyer hereby agrees and stipulates that ABC shall not be liable for any incidental, special, compensatory, expectation, exemplary, punitive or consequential damages, which Buyer may suffer for any reason, including reasons attributable to ABC.
13. Acceptance of Change Orders - Buyer may submit a written request for change orders to ABC adding, deleting or altering the quantity, description or specifications of material ordered. ABC, upon receipt of a written request for change order, shall price the requested change(s) and send to Buyer a price quotation thereof. ABC shall be under no obligation to accept or perform a request for change order unless Buyer unconditionally accepts in writing, without alteration or adjustment, the change order at the prices and terms quoted by ABC.
14. Effect of Sale/Buyer's Delays - All products and materials sold hereunder to Buyer are final and cannot be returned to ABC for credit unless Buyer obtains prior written approval from ABC's authorized representative. If, at Buyer's request, the delivery of materials is delayed, then ABC shall invoice Buyer for the price of materials, which invoice shall be due in accordance with the terms of payment provided herein. Buyer shall reimburse ABC for the cost of storing materials if shipment is delayed by Buyer, and will assume sole and complete responsibility for any and all damages to the materials while in storage, including but not limited to damages caused by deterioration. A 25% restocking fee shall be charged on all returned materials if approved by ABC.
15. Force Majeure - ABC shall not be liable to Buyer for liquidated damages, back charges or loss of use to Buyer arising out of any delay or any other reason in carrying out this Agreement. Under no circumstances shall ABC be liable in any way to Buyer, building owner or any other party for water intrusion or the existence of moisture occurring prior to delivery of ABC's material or existing thereafter or any possible effects resulting therefrom (including fungi, mold or mildew), delays, failure in performance, or loss or damage due to force majeure conditions including, without limitation: fire; flood; epidemics; quarantine; lightning; strike; embargo; explosion; power surge or failure; acts of God; war; labor or employment disputes; civil disturbances; acts of civil or military authority; inability to secure materials, fuel, products or transportation facilities; acts or omissions of suppliers; or any other causes beyond ABC's control, whether or not similar or relating to the foregoing. FURTHER, BUYER HEREBY AGREES AND STIPULATES THAT, IN THE EVENT ABC RECEIVES NOTIFICATION OF A PRICE INCREASE(S) FROM ANY OF ITS SUPPLIERS BETWEEN THE DATE OF THIS AGREEMENT AND THE DATE SCHEDULED FOR DELIVERY OF THE MATERIALS COVERED HEREBY, ABC RESERVES THE RIGHT, IN ITS SOLE DISCRETION AND JUDGMENT, TO INCREASE THE PURCHASE PRICE STATED HEREIN IN AN AMOUNT CORRESPONDING TO SAID PRICE INCREASE(S). Buyer agrees these limitations of ABC's liability are reasonable. Buyer further agrees that these limitations of ABC's liability are material parts of the consideration for this Agreement and is reflected in the amounts charged by ABC hereunder. Buyer intends that these limitations on ABC's liability are to be liberally construed in favor of ABC to eliminate any other liability of ABC other than repair or replacement of defective parts or products.
16. Jurisdiction/Venue/Waiver of Trial by Jury - Buyer hereby acknowledges, stipulates and agrees that (i) any and all claims, actions, proceedings or causes of action relating to the validity, performance, interpretation, and/or enforcement hereof shall be submitted exclusively to a court of competent jurisdiction in Houston, Harris County, Texas, (ii) to the maximum extent practicable, this Agreement will be deemed to call for performance in Houston, Harris County, Texas, (iii) Buyer irrevocably submits itself to the exclusive jurisdiction of the State and Federal courts in Houston, Harris County, Texas, (iv) service of process may be made upon it in any legal proceeding in connection with this Agreement or any other agreement as provided by Texas law, (v) Buyer irrevocably waives, to the fullest extent permitted by law, any objection that it may now or hereafter have to the laying of exclusive venue of any litigation arising out of or in connection with this Agreement or any other agreement or transaction brought in any such court, (vi) Buyer irrevocably waives any claims that litigation brought in any such court has been brought in an inconvenient forum, and (vii) it irrevocably consents to the service of process out of any of the aforementioned courts by the mailing of copies thereof by Certified Mail, Return Receipt Requested, postage prepaid, at its address set forth herein. The scope of each of the foregoing waivers is intended to be all encompassing. Buyer acknowledges that the foregoing waivers are material inducements to the agreement of ABC to enter into a business relationship with Buyer, and that ABC has already relied on these waivers in entering into this Agreement. EACH PARTY HEREBY AGREES NOT TO ELECT A TRIAL BY JURY OF ANY ISSUE TRIABLE OF RIGHT BY JURY, AND FULLY WAIVES ANY RIGHT TO TRIAL BY JURY TO THE EXTENT THAT ANY SUCH RIGHT NOW OR HEREAFTER EXISTS WITH RESPECT TO THIS AGREEMENT AND/OR THE AGREEMENTS, INSTRUMENTS AND DOCUMENTS CONTEMPLATED HEREBY OR ANY CLAIM, COUNTERCLAIM OR OTHER ACTION ARISING IN CONNECTION HEREWITH. EACH PARTY ACKNOWLEDGES AND AGREES THAT THIS WAIVER OF RIGHT TO TRIAL BY JURY IS GIVEN KNOWINGLY AND VOLUNTARILY BY SUCH PARTY AND IS INTENDED TO ENCOMPASS EACH INSTANCE AND EACH ISSUE AS TO WHICH THE RIGHT TO TRIAL BY JURY WOULD OTHERWISE ACCRUE. EITHER PARTY IS HEREBY AUTHORIZED TO FILE A COPY OF THIS SECTION IN ANY PROCEEDING AS CONCLUSIVE EVIDENCE OF THIS IRREVOCABLE WAIVER.
17. Indemnification - BUYER ASSUMES ENTIRE RESPONSIBILITY AND LIABILITY FOR ANY AND ALL CLAIMS OR ACTIONS BASED ON OR ARISING OUT OF INJURIES, INCLUDING DEATH, TO PERSONS OR DAMAGE TO OR DESTRUCTION OF PROPERTY (WHETHER BELONGING TO BUYER, BUILDING OWNER AND/OR ANY THIRD PARTY), SUSTAINED OR ALLEGED TO HAVE BEEN SUSTAINED IN CONNECTION WITH OR TO HAVE ARISEN OUT OF OR INCIDENTAL TO THE PERFORMANCE OF THIS CONTRACT BY BUYER, ITS AGENTS AND EMPLOYEES, AND ITS SUBCONTRACTORS, THEIR AGENTS AND EMPLOYEES, INCLUDING CLAIMS OR ACTIONS FOUNDED IN WHOLE OR IN PART UPON THE ALLEGED ACTS, OMISSIONS, NEGLIGENCE OR FAULT OF ABC, ABC'S REPRESENTATIVES, OR THE EMPLOYEES, AGENTS, INVITEES, OR LICENSEES THEREOF. BUYER HEREBY AGREES TO DEFEND, INDEMNIFY AND HOLD HARM-LESS ABC AND ITS REPRESENTATIVES, AND THE EMPLOYEES, AGENTS, INVITEES AND LICENSEES THEREOF IN RESPECT OF ANY SUCH MATTERS AND AGREES TO DEFEND ANY CLAIM OR SUIT OR ACTION BROUGHT AGAINST ABC, ABC'S REPRESENTATIVE, AND THE EMPLOYEES, AGENTS, INVITEES AND LICENSEES THEREOF. THE PARTIES HEREBY WAIVE THEIR RESPECTIVE RIGHTS UNDER THE DECEPTIVE TRADE PRACTICES-CONSUMER PROTECTION ACT, SECTIONS 17.41 THROUGH 17.63 INCLUSIVE, OF THE TEXAS BUSINESS AND COMMERCE CODE, A LAW THAT GIVES CONSUMERS SPECIAL RIGHTS AND PROTECTIONS. AFTER CONSULTATION WITH LEGAL COUNSEL, EACH VOLUNTARILY CONSENTS TO THIS WAIVER.
18. Severability - Each of the provisions of this Agreement is a separate and distinct agreement and independent of the others. If any provision of this Agreement is found to be invalid or unenforceable in any jurisdiction, such provision shall be fully severable in such jurisdiction, and this Agreement shall be construed and enforced as if in such jurisdiction such provision had never comprised a part hereof. In such event, the remaining provisions of this Agreement shall remain in full force and effect. The terms of this Agreement are intended by the parties as a final expression of their agreement containing all oral and written understandings, past and present, between the parties relative to the materials generally described in this Agreement.
19. Acceptance/Entire Agreement - As a condition precedent to the effectiveness of an order, all orders are subject to approval and acceptance by ABC. This Agreement, along with any attached exhibits, constitutes the entire agreement of the parties herein.



For the most current information available, visit our Web site at www.abcmetalroofing.com

Adel, GA
1601 Rogers Road
Adel, GA 31620
877-595-6604

Lubbock, TX
5711 East FM-40
Lubbock, TX 79401
877-695-0477

Memphis, TN
300 Highway 51 North
Hernando, MS 38632
877-774-0157

Mt. Pleasant, IA
305 N. Iris Road
Mt. Pleasant, IA 52641
877-768-9460

Frankfort, KY
1099 US-421
Frankfort, KY 40601
877-780-2119

Oklahoma City, OK
7000 S. Eastern Avenue
Oklahoma City, OK 73149
877-795-4399

Phoenix, AZ
660 South 91st Avenue
Tolleson, AZ 85353
877-774-6219

Rome, NY
6168 State Route 233
Rome, NY 13440
877-785-0821

Salt Lake City, UT
1155 W 2300 N
Salt Lake City, UT 84116
877-814-1419

