



SP-460 M2 Spin Bike

USER MANUAL



**Read all instructions carefully before using this product.
Retain this owner's manual for future reference.**



IMPORTANT

All nuts and bolts are to be checked and tightened on a regular basis. This includes pedals and other moving parts. Failure to do so may cause damage to your threads and void your warranty.

NOTE:

Product may vary slightly from the item pictured due to model upgrades. This manual may be subject to updates or changes. Up to date manuals are available through our website at www.lifespanfitness.com.au



TABLE OF CONTENTS

I. Important Safety Instructions	03
II. Care Instructions	04
III. Exploded Diagram	05
IV. Parts List	06
V. Assembly Instructions	08
VI. Seat and Handlebar Adjustment	11
VII. Computer Operation	12
VIII. Exercise Guide	15
IX. Warranty	17
X. Hand Pulse Technology	18

I. IMPORTANT SAFETY INSTRUCTIONS

WARNING: Read all instructions before using this machine.

It is important your machine receives regular maintenance to prolong its useful life. Failing to regularly maintain your machine may void your warranty.

Please always keep this manual with you.

- It is important to read this entire manual before assembling and using the equipment. Safe and effective use can only be achieved if the equipment is assembled, maintained, and used properly. **PLEASE NOTE:** It is your responsibility to ensure that all users of the equipment are informed of all warnings and precautions
- Before starting any exercise program, you should consult your doctor to determine if you have any medical or physical conditions that could put your health and safety at risk, or prevent you from using the equipment properly. Your doctor's advice is essential if you are taking medication that affects your heart rate, blood pressure or cholesterol level.
- Be aware of your body's signals. Incorrect or excessive exercise can damage your health. Stop exercising if you experience any of the following symptoms: pain, tightness in your chest, irregular heartbeat, and extreme shortness of breath, lightheadedness, dizziness, or feelings of nausea. If you do experience any of these symptoms, you should consult your doctor before continuing with your exercise program.
- Keep children and pets away from the equipment. This equipment is designed for adult use only.
- Use the equipment on a solid, flat level surface with a protective cover for your floor or carpet. To ensure safety, the equipment should have at least 2 meters of free space around it.
- Before using the equipment, check that the nuts and bolts are securely tightened. If you hear any unusual noises coming from the equipment during use and assembly, stop immediately. Do not use the equipment until the problem has been rectified.
- Wear suitable clothing while using the equipment. Avoid wearing loose clothing that may get caught in the equipment or that may restrict or prevent movement.
- This equipment is designed for indoor and family use only.
- Care must be taken when lifting or moving the equipment so as not to injure your back.

- Always keep this instruction manual and assembly tools at hand for reference.
- The equipment is not suitable for therapeutic use.
- The pulse or heart rate sensors are not medical devices. Various factors, including the user's movement, may affect the accuracy of heart rate readings. The pulse sensors are intended only as exercise aids in determining heart rate trends in general.

II. CARE INSTRUCTIONS

IMPORTANT

- a. All nuts and bolts are to be checked and tightened on a regular basis. This includes pedals and other moving parts. **Failure to do so may cause damage to your threads and void your warranty.**
 - b. Lubricate moving joints after periods of usage.
 - c. Be careful not to damage plastic or metal parts of the machine with heavy or sharp objects.
 - d. The machine can be kept clean by wiping it down using dry cloth.
-

BATTERY USAGE

- a. Batteries are to be installed or replaced by adult only.
- b. Do not use rechargeable batteries. Do not mix different battery types. Do not mix old and new batteries. Do not mix alkaline, standard (Carbon Zinc), or rechargeable (Nickel-Cadmium) batteries.
- c. Remove batteries when product is not in use.
- d. Remove exhausted batteries from product and dispose of in accordance with the manufacturer's recommendation.
- e. Do not attempt to recharge non-rechargeable batteries.
- f. Batteries are to be inserted with correct polarity.
- g. The supply terminals are not to be short-circuited.
- h. Do not dispose of batteries in fire, batteries may explode or leak.

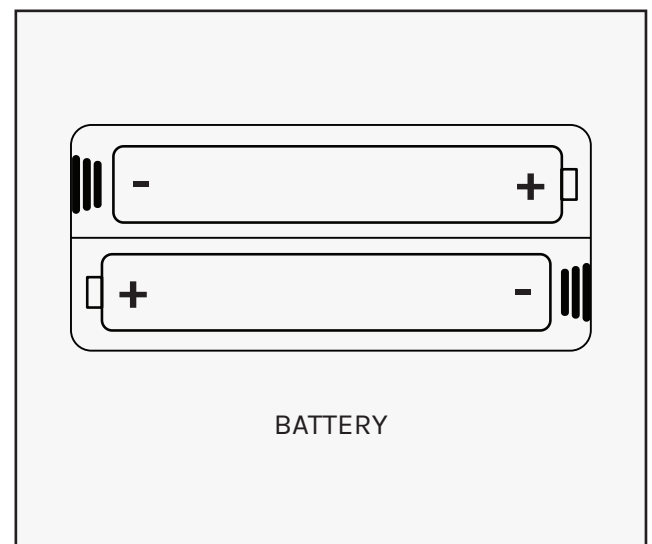

III. EXPLODED DIAGRAM

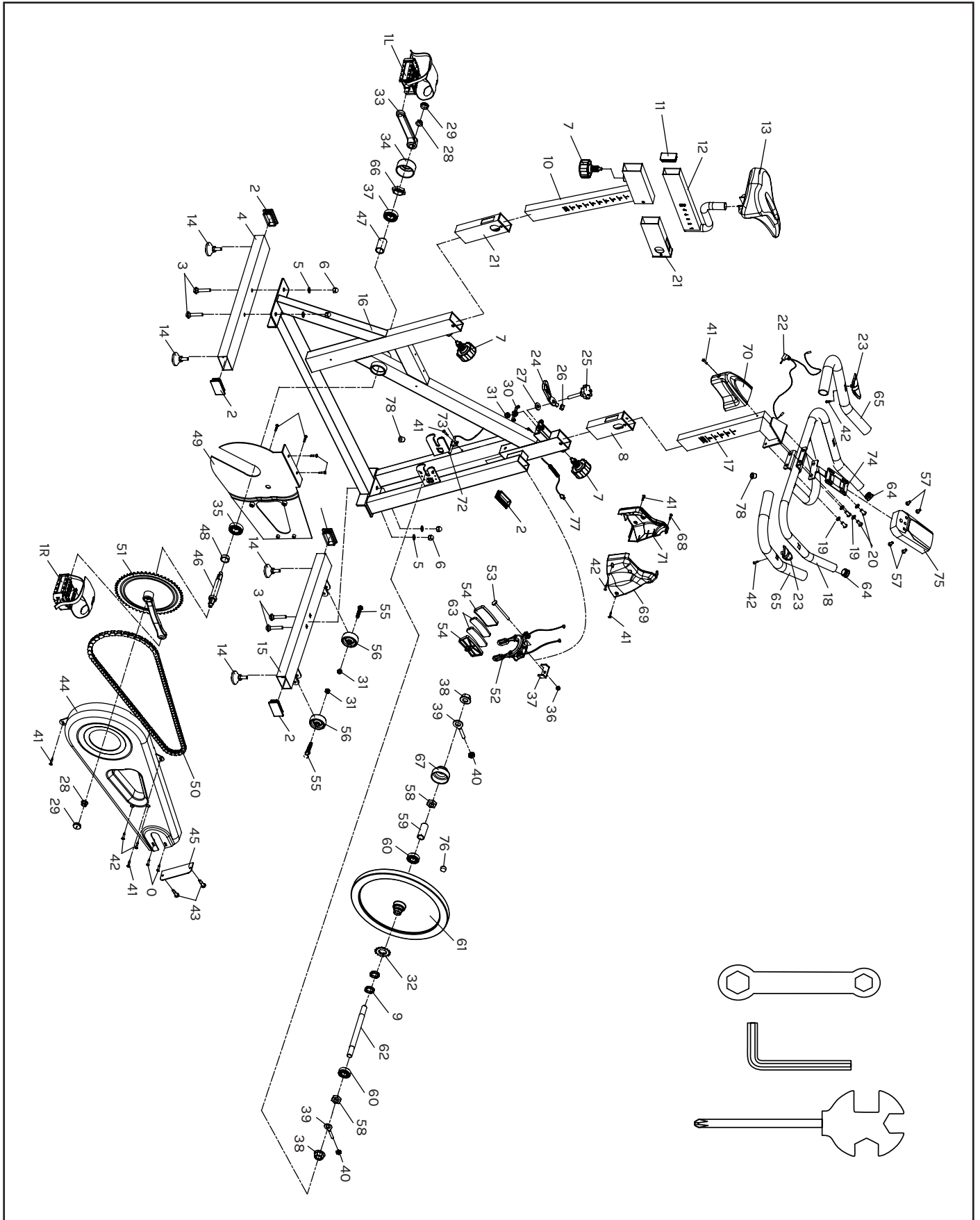

IV. PARTS LIST

No.	Name	Spec.	Quantity	Unit
1	Pedal	JD-301 (9/16")	1	pcs
2	End Cap	60*30*1.5	5	pcs
3	Carriage Bolt	8*42	4	pcs
4	Rear Stabilizer	Wedling	1	pcs
5	Flat Washer	8	4	pcs
6	Domed Nut	M8	4	pcs
7	Spring Adjustment Knob	φ57*62 (M16*1.5)	3	pcs
8	Plastic Sleeve	53.5*23.5*1.5/60*30*1.5	1	pcs
9	Lock Nut	M33*1*4	2	pcs
10	Vertical Seat Post	Wedling	1	pcs
11	End Cap	53.5*23.5*1.5	1	pcs
12	Seat Post	Wedling	1	pcs
13	Seat	C-3604T/NT-189	1	pcs
14	Stopper	φ38*43/(M8X25)	4	pcs
15	Front Stabilizer	Wedling	1	pcs
16	Main Frame	Wedling	1	pcs
17	Handlebar Post	Wedling	1	pcs
18	Handle Bar	Wedling	1	pcs
19	Spring Washer	8	4	pcs
20	Bolt	M8*15	4	pcs
21	Bushing	φ40*65	2	pcs
79	Pulse Sensor	match Ø25 tube	1	pcs
80	Pulse Sensor Line	L=700	1	pcs
24	Brake Knob	112*32*7	1	pcs
25	Adjustment Knob	φ58*74	1	pcs
26	Little Plastic Ring	14*8*9	1	pcs
27	Plastic Ring	φ20*φ9*3	1	pcs
28	Fixing Nut	M10*1.25	2	pcs
29	Crack End Cap	φ23*7.5	2	pcs
30	Sheet Iron	δ5	1	pcs
31	Lock Nut	M8	3	pcs
32	Chain Wheel	A7K-16 1/2"*1/8" 16T	1	pcs
33	Left Crank	170*43	1	pcs
34	Crank Cover	φ45*28	1	pcs
35	Bearing	6203ZZ	2	pcs
36	Domed Nut	M6	1	pcs
37	U Bracket	δ2.5	1	pcs
38	Fixing Nut	M10*1.0	2	pcs
39	Fixing Bolt	M6*55	2	pcs
40	Nut	M6	2	pcs

No.	Name	Spec.	Quantity	Unit
41	Screw	ST4.2X19	7	pcs
42	Screw	ST4.2X16	5	pcs
43	Screw	ST4.2X13	2	pcs
44	Outer Chain Cover	636*265*40	1	pcs
45	Little Chain Cover	108*37*3.5	1	pcs
46	Axis	φ20*137	1	pcs
47	Long Fixing Tube	φ22*φ17.5*36	1	pcs
48	Short Fixing Tube	φ22*φ17.5*11	1	pcs
49	Inner Chain Cover	451*262*32	1	pcs
50	Chain	12.7/106	1	pcs
51	Right Crank	170*48	1	pcs
52	Brake	130mm	1	pcs
53	Special Bolt	M6*75	1	pcs
54	Brake Plastic	85*43*13	2	pcs
55	Bolt	M8*40	2	pcs
56	Wheel	φ50*23	2	pcs
81	Screw	M5*12	4	pcs
58	Fixing Nut	M10*1.0	2	pcs
59	Fixing Tube	φ13.6*φ10.3*35	1	pcs
60	Bearing	6000ZZ	2	pcs
61	Flywheel	φ453*27 (17.5KG)	1	pcs
62	Flywheel Shaft	φ10*147	1	pcs
63	Woolly Block	85*40*6	2	pcs
64	End Cap	φ25*1.5	2	pcs
65	Foam Grip	φ23*φ33*465	2	pcs
66	Fixing Nut	φ28*M20*1	1	pcs
67	Flywheel Cover	φ59*35	1	pcs
68	Screw	ST2.9*9.5	1	pcs
69	Left Protect Cover	157*73*157	1	pcs
70	Handlebar Cover	115*89*75	1	pcs
71	Right Protect Vover	156*80*174	1	pcs
72	Sensor	SR-202	1	pcs
73	Sensor Holder	LTF8163	1	pcs
74	Computer Holder	δ2.5	1	pcs
75	Computer	X-3541	1	pcs
76	Magnetic	LT-310	1	pcs
77	Magnet	φ15*7, LT-310	1	pcs
78	Plastic Plug	φ14*14 (φ12)	3	pcs

V. ASSEMBLY INSTRUCTIONS

1. PREPARATION

- A. Before assembling make sure that you will have enough space around the item.
- B. Use the present tooling for assembling.
- C. Before assembling please check whether all needed parts are available (at the above of this instruction sheet you will find an explosion drawing with all single parts (marked with numbers) which this item consists of.

2. ASSEMBLY INSTRUCTION

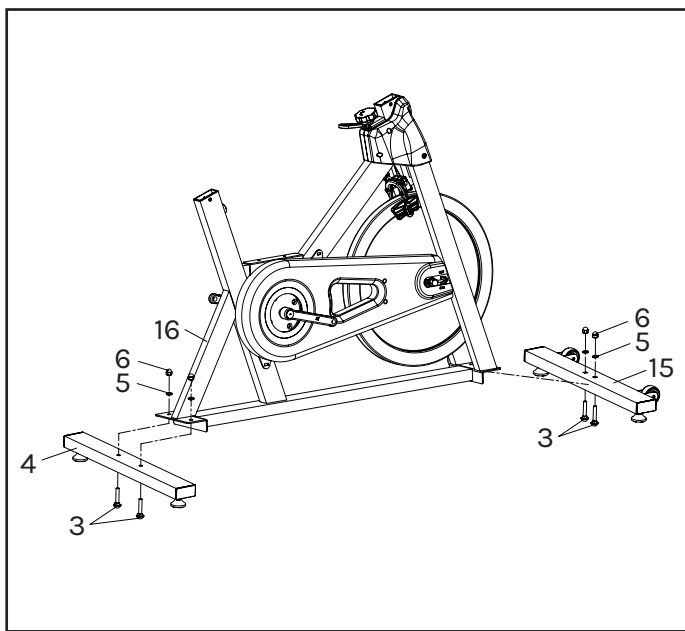

FIG 1

1. Remove the bolts and nut from the bottom tube, then attach the Front Stabilizer (pt.15) to the Main Frame (pt.16) using two sets of Ø8 Flat Washers (pt.5), M8 Domed Nut (pt.6) and M8*45 Carriage bolt (3).
2. Attach the Rear Stabilizer (pt.4) to the Main Frame (pt.16) using two sets of Ø8 Flat Washers (pt.5), M8 Domed Nut (pt.6) and M8*45 Carriage bolt (3).

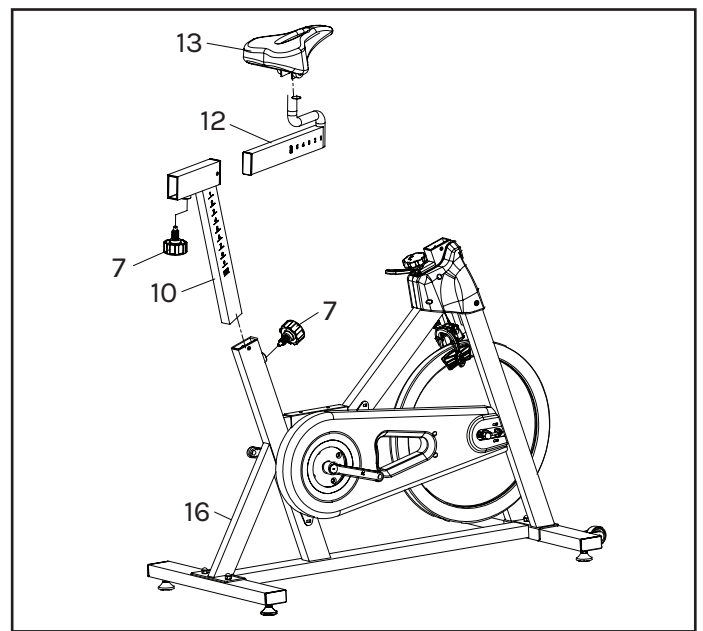
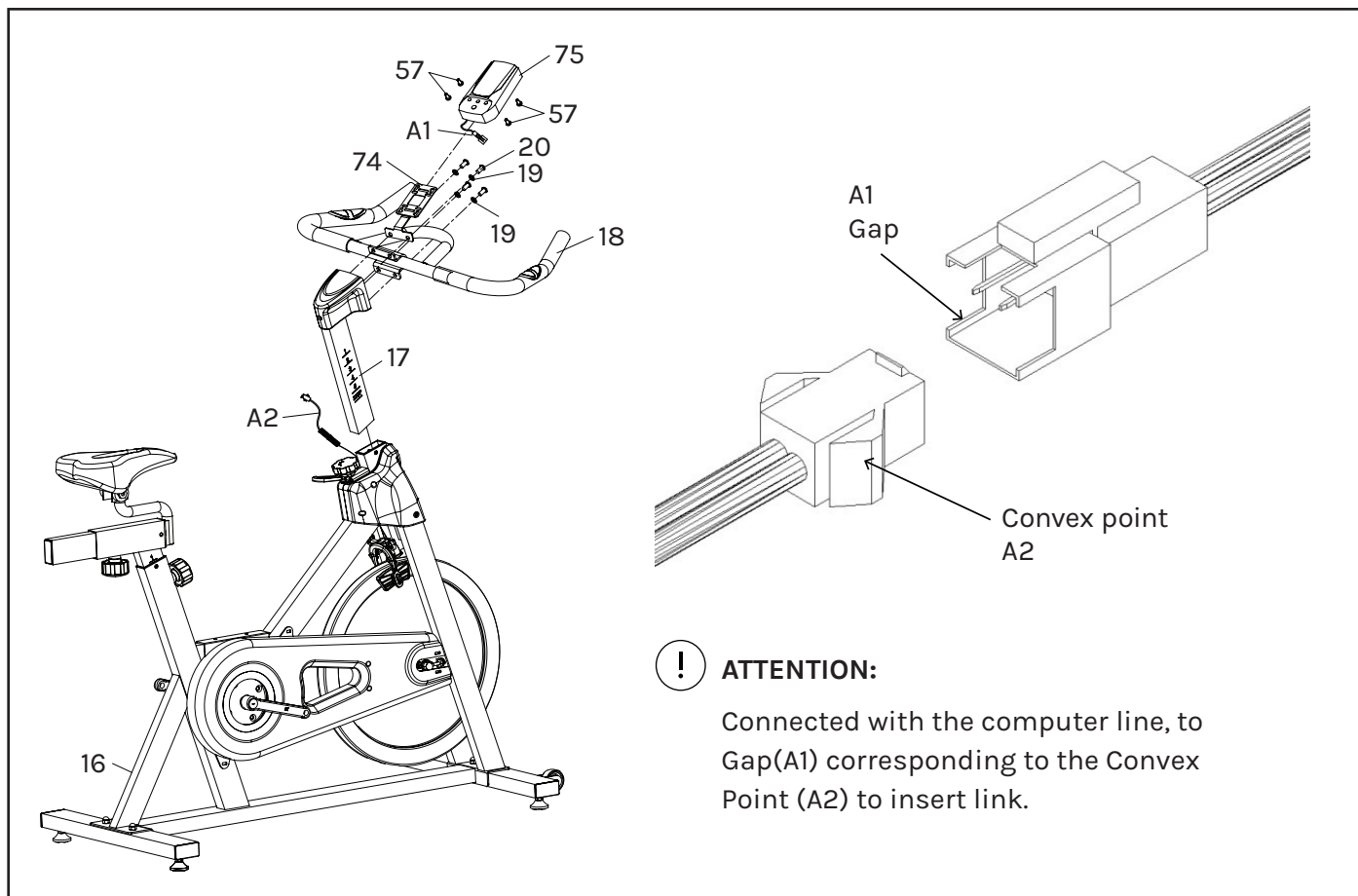

FIG 2

1. Slide the Vertical Seat Post (pt.10) into the seat post housing on the main frame (pt.16). Then slide the Seat Post (pt.12) into the Vertical Seat Post (pt.10). You will have to slacken the knurled section of the Spring Adjustment Knob (pt.7) and pull the knob back and then select and align holes for the desired height. Release the knob and retighten the knurled portion.
2. Now fix the Seat (pt.13) to the Vertical Seat Post (pt.12) as shown and tighten the bolts around the screws under the seat.



! ATTENTION:
 Connected with the computer line, to Gap(A1) corresponding to the Convex Point (A2) to insert link.

FIG 3

1. Slide the Handlebar Post (pt.17) into the handlebar post housing on the main frame. You will have to slacken the knurled section of the Spring Adjustment Knob (pt.7) and pull the knob back and then select and align holes for the desired height. Release the knob and retighten the knurled portion.
2. Then fix the Handlebar (pt.18) and the Computer Holder (pt.74) with two sets of Ø8 the Spring Washer (pt.19) and M8*15 the Bolt (pt.20).

! ATTENTION: YOU SHOULD FIX THE HANDLEBAR TIGHTLY.

3. Slide the Computer (pt.75) onto the Computer Holder (pt.74) by connecting the plug (A1 & A2).

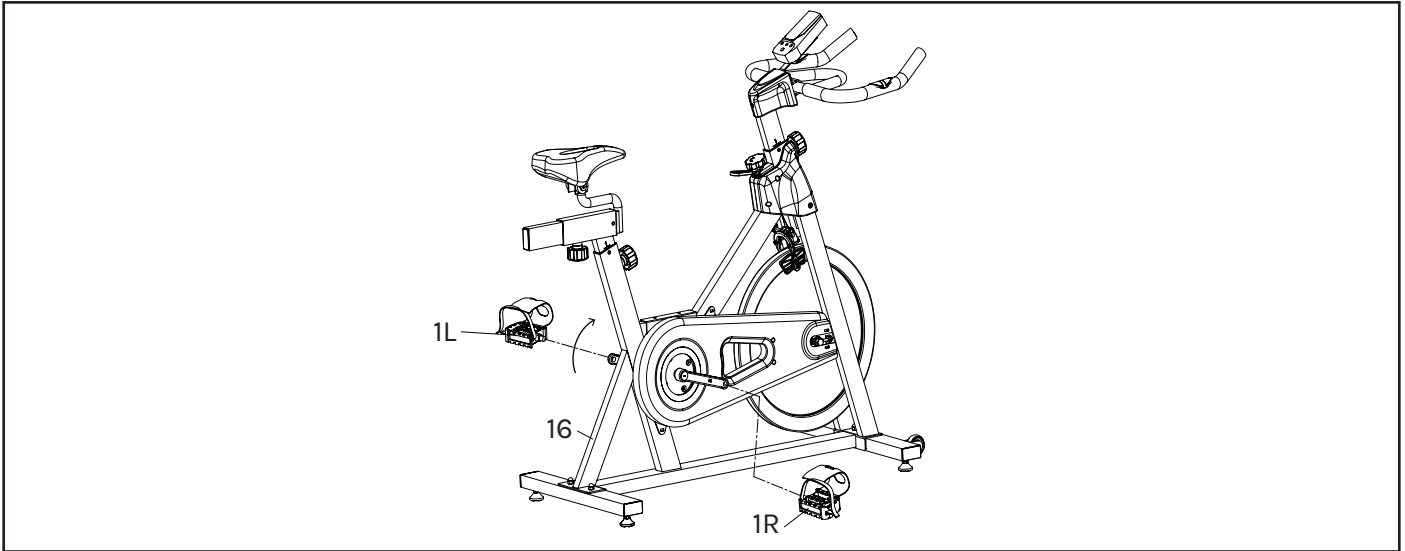

FIG 4

1. The Pedals (pt.1 L & pt.1 R) are marked "L" and "R" - Left and Right. Connect them to their appropriate crank arms. The right crank arm is on the right- hand side of the cycle as you sit on it.

! **IMPORTANT:** The Right pedal should be threaded on clockwise and the Left pedal anticlockwise. Ensure to fully tighten both pedals as loose pedals will cause damage to the thread and this will affect your warranty.

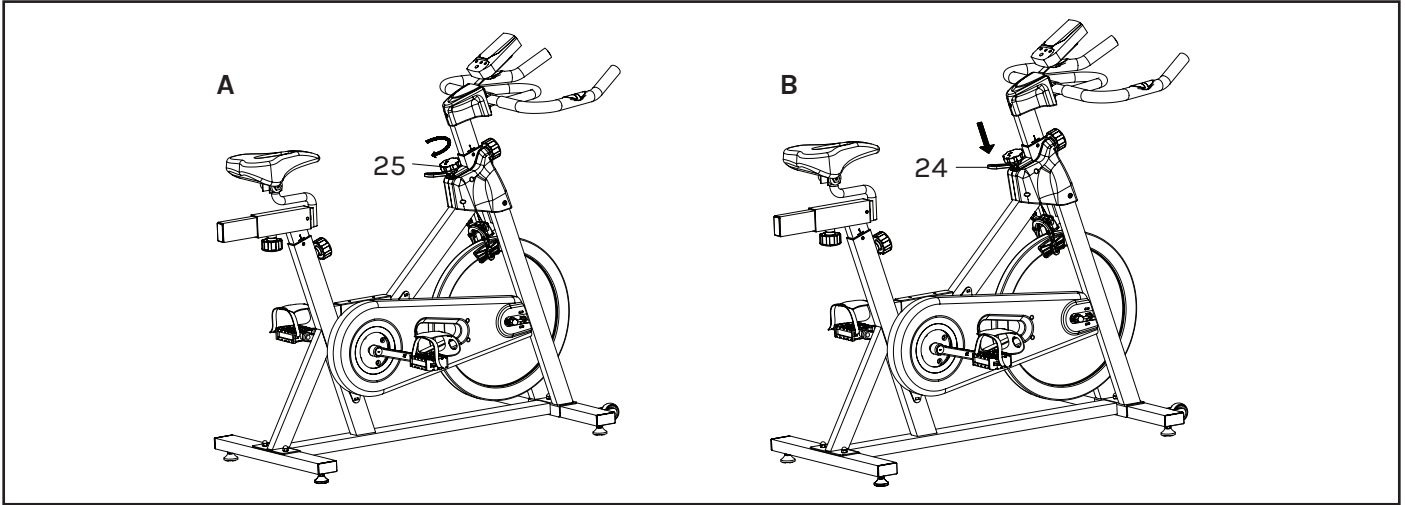

FIG A

A. Adjust the resistance:
 To increase resistance (requiring more strength to pedal), turn the Resistance Control Knob (pt.25) to the right.

 To decrease resistance (requiring less strength to pedal), turn the Resistance Control Knob (pt.25) to the left.

FIG B

B. The Emergency Brake Function:
 The Emergency Brake & Resistance Control Knob can be used as the Emergency Brake. When you want the flywheel to stop turning, you must firmly press down the Emergency Brake (pt.24).

VI. SEAT AND HANDLEBAR ADJUSTMENT

SEAT ADJUSTMENT

To adjust the seat height, slacken the spring knob on the vertical post stem on the main frame and pull back the knob. Position the vertical seat post for the desired height so that holes are aligned, then release the knob and retighten it.

To move the seat forward in the direction of the handlebar or backwards away from it, loosen the adjusting knob and washer and pull the knob back. Slide horizontal seat post into desired position. Align holes and then retighten the adjusting knob.

HANDLEBAR ADJUSTMENT

To adjust the handlebar height, slacken the spring knob and secondary knob and pull both knobs back. Slide the handlebar post along the housing on the main frame to the desired height and, with the holes aligned correctly, tighten the spring adjusting knob and then the secondary knob.

VII. COMPUTER OPERATION

BUTTONS

MODE	To confirm all settings.
SET	To set up the value of TIME, DISTANCE, CALORIES and PULSE. You can hold the button to increase the value fast. (The computer must be in stop condition.)
RESET	To clear the set-up value. Press RESET key and hold for 2 seconds to reset all function figures.
RECOVERY	To test heart rate recovery status.

FUNCTIONS

SCAN	Displays all function TIME→DISTANCE→CALORIES→PULSE→RPM/SPEED in sequence.
RPM	Displays the pedalling Rotation Per Minute. The RPM and SPEED will switch to another display in every 6 seconds after exercise starts.
SPEED	Displays the user's exercise speed.
TIME	<ol style="list-style-type: none">1. You can press "SET" button to set target time between 0:00 to 99:00 for count down function.2. It can be set up by the user or accumulated automatically for count up function.
DISTANCE	<ol style="list-style-type: none">1. You can press "SET" button to set target distance between 0:00 to 99:50 for count down function.2. It can be set up by the user or accumulated automatically for count up function.
PULSE	Displays the user's pulse. User may set the target pulse. When pulse value reaches to the target, the computer will alarm with "Bi" sound.

OPERATION PROCEDURE

1. Installs 2 pieces of 1.5V #4 batteries, then the screen will display as following "Drawing A" and have "Bi" sound at the same time.

After that, it goes to the next step to the main menu as "Drawing B".

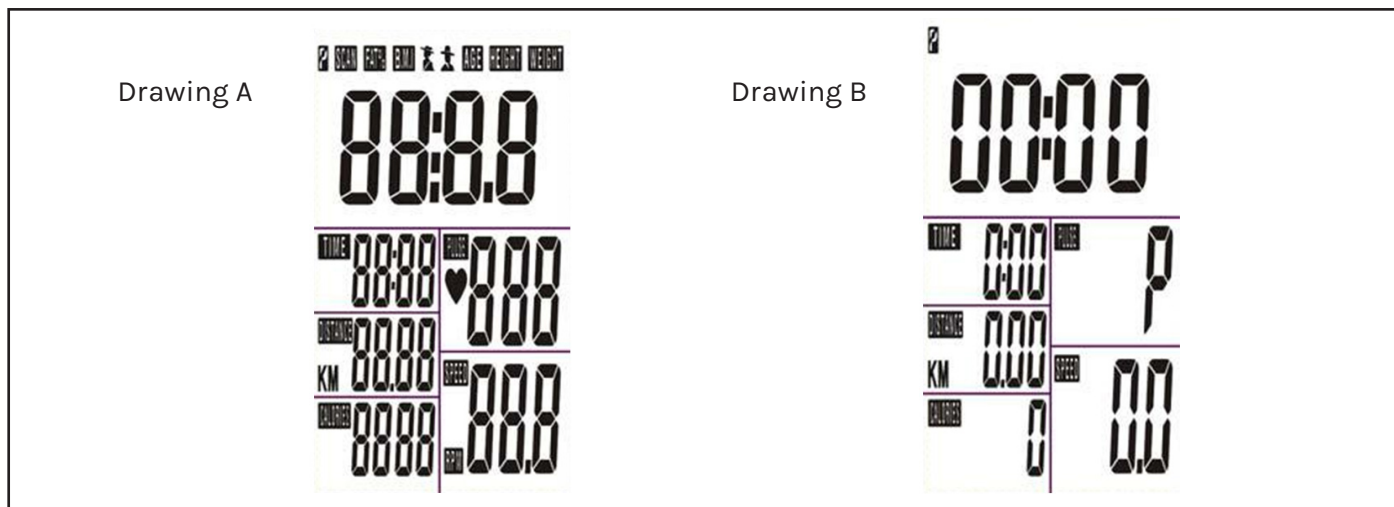

2. Get access to the set-up mode of TIME/DISTANCE/CALORIES/PULSE.

When you are in each set-up mode, for example in the time set-up mode, time value is blinking, you can press "SET" button to adjust the value and press "MODE" for confirmation. The set-up of DISTANCE, CALORIES & PULSE is the same as TIME.

3. With any signal been transmitted into the monitor, the value of TIME, DISTANCE, CALORIES start to count up as Drawing C. When there is any function has been pre-set the target (TIME or DISTANCE or CALORIES), the function will be counting down from the pre-set to zero while the training starts. Once the target is achieved to zero, the monitor start to beep for 8 seconds, and the function will be counting up from zero directly if the training is going. Press "MODE" button for confirmation and skip to next set-up.

4. In SCAN mode shown as "Drawing C". RPM/SPEED TM/DIST/CAL/PULSE will skip to display in every 6 seconds. The order is as follows.

5. You can also press "MODE" button to select single function display except RPM & SPEED function. The RPM & SPEED function will switch display.

6. RECOVERY:

a. When the user presses "RECOVERY" button, the RECOVERY function is active. At this time only PULSE and TIME is working, other functions will not be displayed, and the Sensor Input is not available. TIME starts to count down from "0:60", Pulse signal will be blinking according user's heart rate BPM. When Time counts down to "0", it will show F1-F6. (F1 is the best, F6 is the worst).

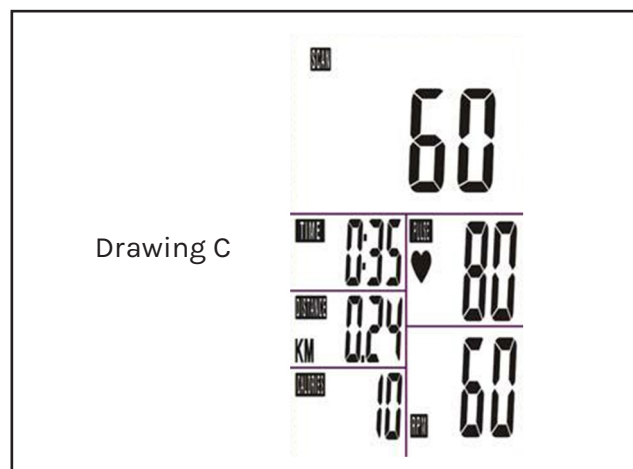

F1	Outstanding
F2	Excellent
F3	Good

F4	Fair
F5	Below Average
F6	Poor

b. LCD display as follows: (RECOVERY start condition & end condition).

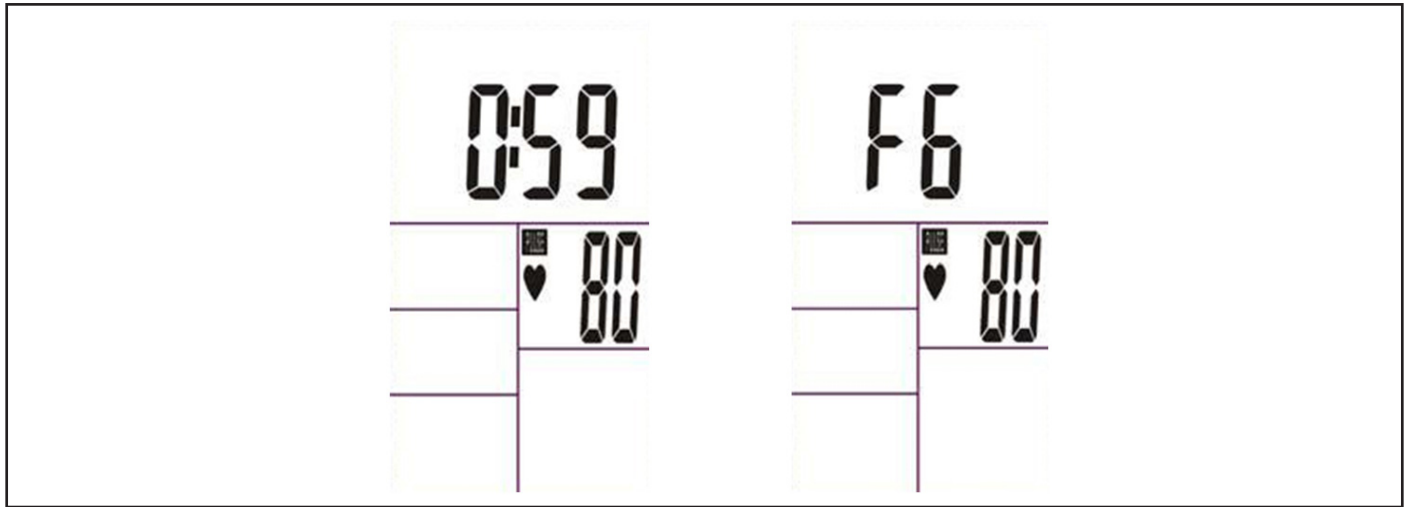

c. If the countdown action to 0:00 is not completed and there is no pulse signal, the countdown action must be done and shown F6.

d. If you press the RECOVERY button prior to count down to 0:00, it will be end and return to the main menu.

! **NOTE:**

1. Stop training for 4 minutes, the computer will enter to Sleep mode.
You may press any button to have the computer restart working, the original value will retain. (If re-install batteries, the original value will remove.)
2. If the computer displays abnormally, please re-install batteries and try again.
3. Battery Spec: 1.5V UM-4 or AAA (2PCS).

VIII. EXERCISE GUIDE

! PLEASE NOTE:

Before beginning any exercise program, consult your physician. This is important especially if you are over the age of 45 or individuals with pre-existing health problems.

The pulse sensors are not medical devices. Various factors, including the user's movement, may affect the accuracy of heart rate readings. The pulse sensors are intended only as an exercise aid in determining heart rate trends in general.

Exercising is great way to control your weight, improving your fitness and reduce the effect of aging and stress. The key to success is to make exercise a regular and enjoyable part of your everyday life.

The condition of your heart and lungs and how efficient they are in delivering oxygen via your blood to your muscles is an important factor to your fitness. Your muscles use this oxygen to provide enough energy for daily activity. This is called aerobic activity. When you are fit, your heart will not have to work so hard. It will pump a lot fewer times per minute, reducing the wear and tear of your heart.

So as you can see, the fitter you are, the healthier and greater you will feel.

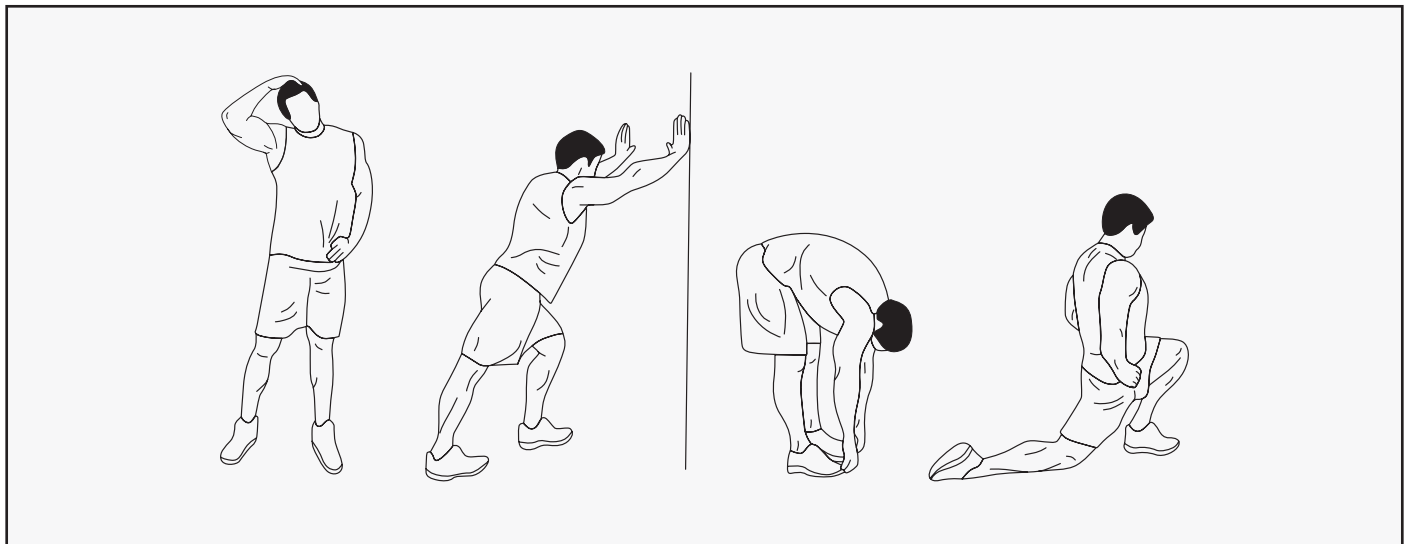

WARM UP

Start each workout with 5 to 10 minutes of stretching and some light exercises. A proper warm-up increases your body temperature, heart rate and circulation in preparation for exercise. Ease into your exercise.

After warming up, increase the intensity to your desired exercise program. Be sure to maintain your intensity for maximum performance. Breathe regularly and deeply as you exercise.

COOL DOWN

Finish each workout with a light jog or walk for at least 1 minute. Then complete 5 to 10 minutes of stretching to cool down. This will increase the flexibility of your muscles and will help prevent post-exercise problems.

WORKOUT GUIDELINES

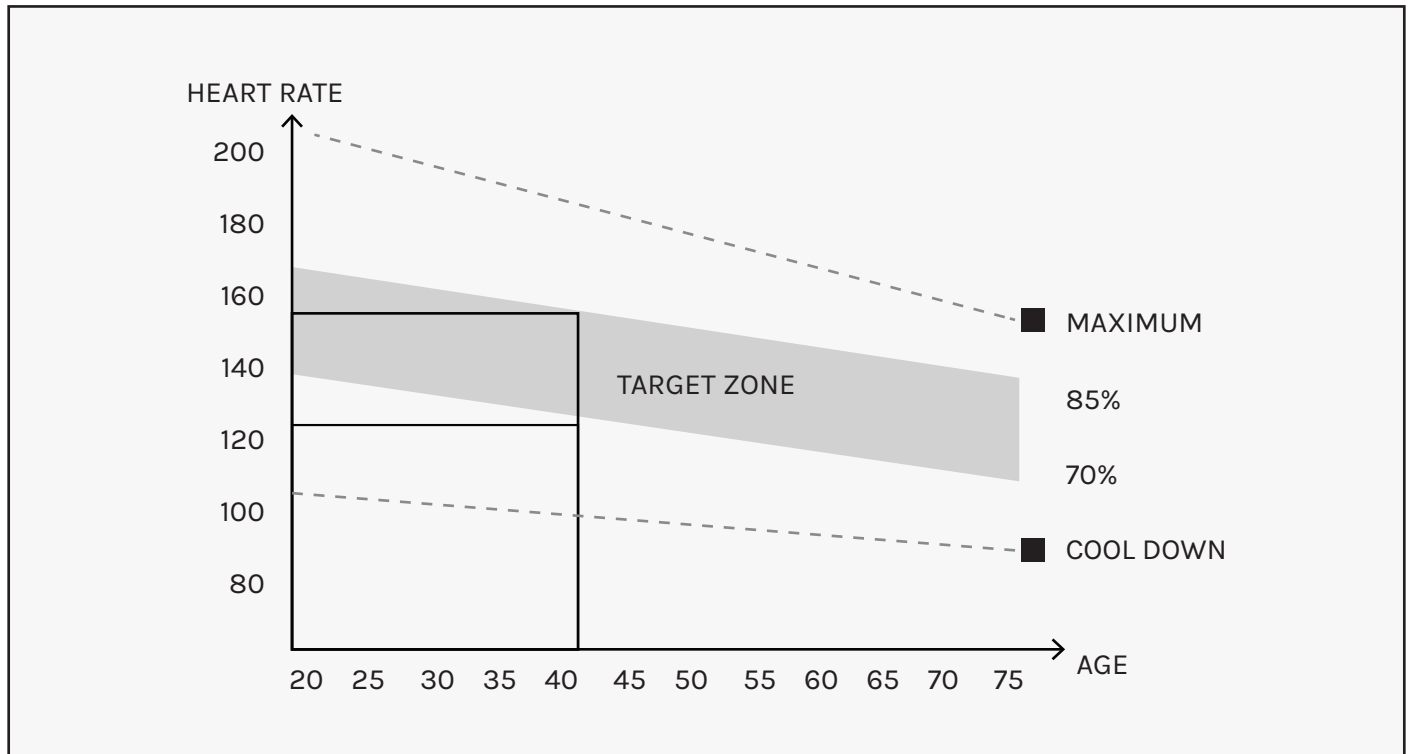

! This is how your pulse should behave during general fitness exercise. Remember to warm up and cool down for a few minutes.

IX. WARRANTY

AUSTRALIAN CONSUMER LAW

Many of our products come with a guarantee or warranty from the manufacturer. In addition, they come with guarantees that cannot be excluded under the Australian Consumer Law. You are entitled to a replacement or refund for a major failure and compensation for any other reasonably foreseeable loss or damage.

You are entitled to have the goods repaired or replaced if the goods fail to be of acceptable quality and the failure does not amount to a major failure. Full details of your consumer rights may be found at www.consumerlaw.gov.au.

Please visit our website to view our full warranty terms and conditions:
<http://www.lifespanfitness.com.au/warranty-repairs>

WARRANTY AND SUPPORT

Please email us at support@lifespanfitness.com.au for all warranty or support issues.

For all warranty or support related enquiries an email must be sent before contacting us via any other means.

X. HAND PULSE TECHNOLOGY

This product comes equipped with hand pulse sensors which are used to pick up tiny EKG/ECG signals that run through the body when your heart beats. These electrical EKG/ECG signals are very small and that they must be amplified 1000 times to make the signal useful for the computer to display your pulse.

To ensure proper operation:

- The user must maintain good, consistent contact on all four sensors.
- The users skin cannot be too dry or too wet.

Other factors that could affect the reading:

- Change of grip on the sensors (during slow pace walking and up to running).
- Tightening of hand muscles will produce small electrical signal.
- Static electricity charges from the air or from walking on the treadmill.

EKG/ECG Sensors may filter through actual EKG/ECG signals and "Noise" factors that may affect the reading. This will cause the pulse reading to be delayed and will take longer to update the display as the heart rate changes. Too much noise will create an incorrect reading. Medical conditions or having no electrical signal in the hands are other factors that may affect pulse readings as well.

These are limitations of hand pulse technology and even the most expensive systems (which can cost upwards of \$3,000) used in hospitals have the same problems. The difference is that a patient in a hospital is not running on a treadmill. Hand pulse technology works well on stationary exercise machines like bikes and even elliptical cross trainers but are not perfect on a treadmill. We offer treadmills with a wireless heart rate receiver which may be a more accurate option.

To test if your hand pulse sensors are working up to specification, hold them while standing on the sidestep rails, not walking, and see if the reading is more in line with what you would expect. This will eliminate the movement and static electricity factors. If your hands are dry, then wet them slightly (saliva works as a great conductor if this doesn't bother you).

For more information, please contact our Lifespan Fitness Technical Support Department
www.lifespanfitness.com.au
support@lifespanfitness.com.au



WWW.LIFESPANFITNESS.COM.AU