

AIR SPARGE PILOT CART ELEVATION DETAIL

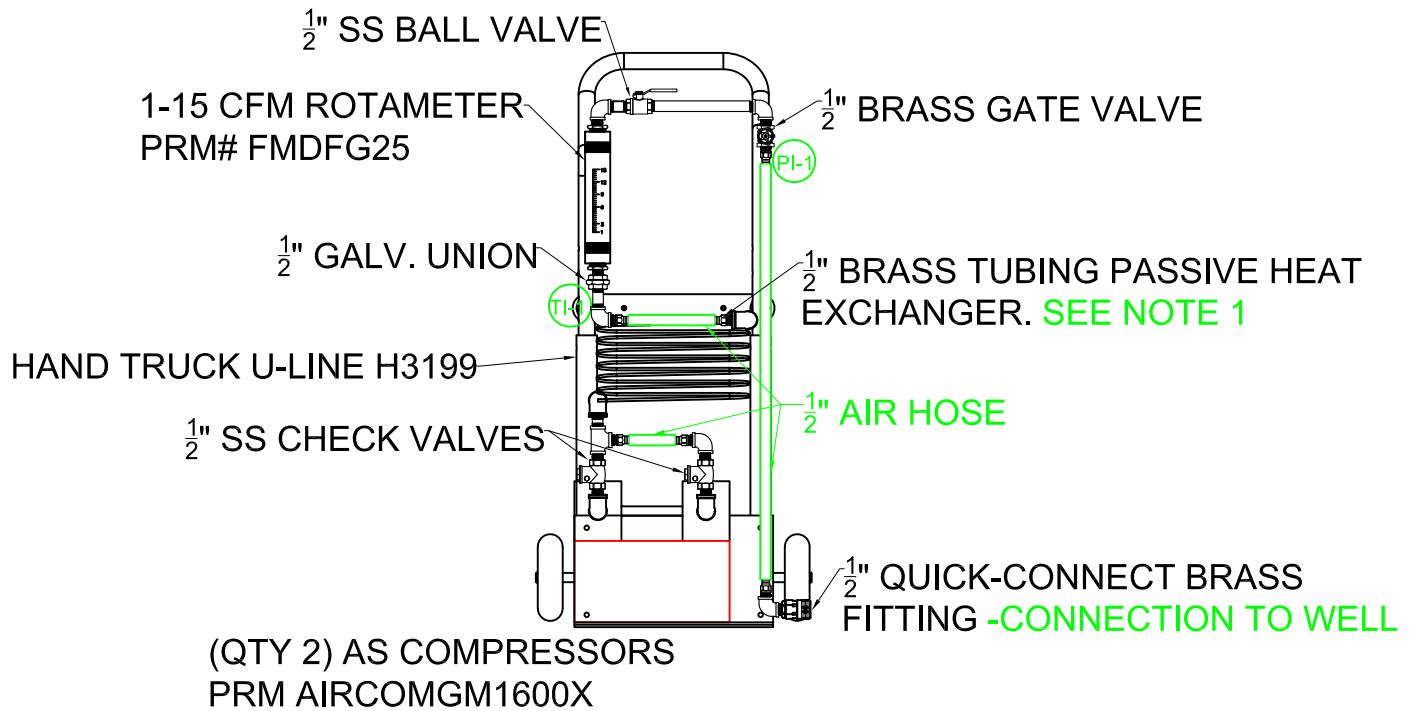

GENERAL NOTES: **1.6 KW 240V 1PH ODP SEE NOTES 2 & 3**

- BRASS TUBING WILL BE COILED TO MAXIMIZE LENGTH. 10'-30' TOTAL LENGTH. COIL CAN GO BEHIND PLUMBING. SHOWN AS-IS FOR DRAWING CLARITY
- THERE SHALL BE 2 COMPRESSORS. 2ND UNIT'S LOCATION TBD AND SHALL BE PLUMBED INTO BRASS TUBING PASSIVE HEAT EXCHANGER.
- THERE SHALL BE A SINGLE 240V, 15A PLUG W/ 25' OF CABLE WOUND ON A SIDE BRACKET. 240V FEED WILL SPLIT AND THERE WILL BE A SINGLE OVERLOAD/SWITCH FOR EACH COMPRESSOR. THE OVERLOAD/SWITCHES SHALL BE EASILY ACCESIBLE.
- COMPRESSORS SHALL HAVE GALV. RAIN GUARDS OVER MOTOR ENDS.

LOOSE EQUIPMENT:

- 10' OF 200 PSI AIR HOSE WILL BE PROVIDED W/ 1/2" MALE QUICK CONNECT FITTING ON ONE END AND 1/2" FEMALE QUICK CONNECT FITTING ON THE OTHER END

PRM PARTS LISTS

PRM PARTS	DESCRIPTION	PRM #
PI-1	0-100 PSI LF GAUGE	PGCNBTY6302515100PSI
PI-2	32-250 DEG F TEMP GAUGE	THERMOBTY760563

ELECTRICAL

1. VOLTAGE	240V
2. PHASE	1
3. AUTO RESTART	NO

Scale (ft.)

