

Ultrasonic flow meter manual



PHI-100F MANUAL(VER. 18)

CONTENTS

1. OUTLINE.....	4
§1.1 Preface.....	4
§1.2 Principle of Measurement	5
2. Starting Measurement.....	6
§2.1 wall mounted fixed style ultrasonic flowmeter.....	6
3 display and operation.....	9
§3.1.1 key function.....	9
§3.1.2 detailed information of Menu.....	10
§3.1.3 Work parameter solidification of the flow meter and option introduction.....	16
§3.1.4 Zero point setup and zero point solidification.....	16
§3.1.5 Factory use the scaling factor solidification.....	17
§3.1.6 analogue calculating function application.....	17
§3.1.7 Analogue input interface as digit input interface method and introduction.....	17
§3.1.8 Introduction of serial peripheral extension interface.....	17
§3.1.9 Realize medium identifying function.....	17
§3.2 The flow meter restore to factory default.....	17
4.transducers installation.....	18
§4.1 Unpack checking.....	18
§4.2 Power supply and cable.....	18
§4.3 Required installation condition.....	18
§4.3.1 choosing measurement point.....	18
§4.3.2 instrument well construction requirements	21
§4.4 Quickly input pipe parameter steps:.....	22
§4.5 Clamp on type transducer installation method	22
§4.5.1 Installation space.....	23
§4.5.2 Installation method.....	23

§4.6 Insertion type transducer installation method	25
§4.6.1 Installation tools	26
§4.6.2 Installation space	26
§4.6.3 Installation method	26
§4.6.4 Locate the installation point	26
§4.6.5 Welding the base of the ball valves	27
§4.6.6 hole-drilling	28
§4.6.7 inserting the transducers	28
§4.6.8 Length calculation of the part of transducer into the pipe inner wall:	29
§4.6.9 wiring	29
§4.6.10 Transducer wiring picture	29
§4.6.11 Maintenance	30
§4.7 In-line type transducer installation method	30
§4.8 check installation of transducers	32
§4.8.1 Signal Strength	32
§4.8.2 Signal quality(Q value)	32
§4.8.3 Total transit time,delta time	32
§4.8.4 Transit time ratio	33
§4.8.5 Note the following questions when installing	33
§5. Troubleshooting	34
§6 Warranty and service	37
§6.1 Warranty	37
§6.2 Service	37
§6.3 Software Upgrade Service	37
§6.4 Important Notice for Product Return	37

1.Outline

§1.1 Preface:

Welcome to use the new PHI-100F series ultrasonic flowmeter invented by kaifeng qingtianweye flow Instrument Co.,Ltd .

up to date, the high fuction,low price,good reliability,power function,new series products enhanced greatly in the aspects of measurement accuracy,measurement stability,communication protocol,easy to use etc. easy and reliable production line,good conformity of the products that gurantees each instrument reach the best function before leaving factory.

The main board is suitable for any kinds of transducers,including clamp-on type,insertion type, π in-line type,standard in-line type and same kinds of transducers from other manufacturers.the pipe parameters and calibration parameters of water meter and in-line pipe are input by manufacturer,users do not need to input any parameter,only need to connect with flowmeter to work.

Applied to on-line measure and system monitor for nearly all liquids from petrol chemical,metallurgy,electric power plant,irrigation,city water company,energy monitor fields,realize the functions of measuring and checking of flow velocity,flow rate,accumulation and heat quantity of different liquids,and flow rate on/off,liquids distinguish.



§1.2 Principle of Measurement

When the ultrasonic beam is transmitted through the flowing liquid, there will be a difference between the upstream and downstream transit time (travel time or time of flight), which is proportional to flow velocity, when fluid is flowing, counterflow transit time is more than direct flow transit time. the formula as below.

$$V = \frac{MD}{\sin 2\theta} \times \frac{\Delta T}{T_{up} \cdot T_{down}}$$

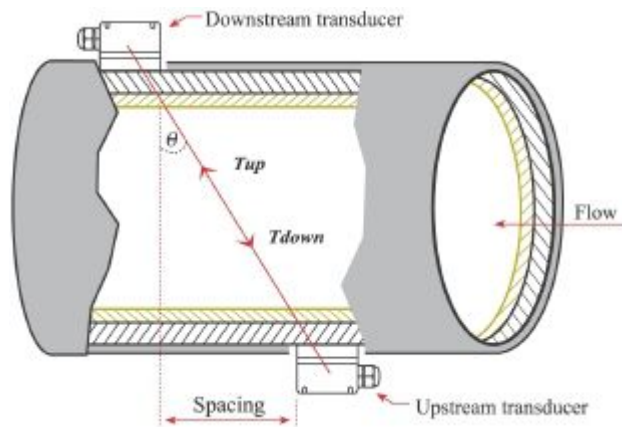

Remarks:

- θ The angle between the ultrasonic beam and the flow
- M Transit times of the ultrasonic beam
- D The internal diameter of the pipe
- Tup Transit time in the forward direction
- Tdown Transit time in the reverse direction
- ΔT=Tup –Tdown

$$F=900 \times \pi \times D_2 \times V$$

F is instant flow rate(unit:m³/hour)

D is inside pipe diameter(unit:m)

V is flow velocity(unit:m/s)

2. Starting Measurement

The new instruments are comprised of measuring main board,function extending module,and display operation terminal etc.users can choose the right configuration according to own requirements.the easiest configuration only needs a measuring main board and a pair of transducers to complete the function of flow measurement.

§2.1 wall mounted fixed style ultrasonic flowmeter

transducers include clamp-on type,insertion type,in-line type.these series products have gained the best sales volume in our company,and are the favorable products in future,applied to measure on-line differents liquids in industry spot.

Technology features:

1:operating power :AC 85—264V or isolation DC 8-36VDC

2:repeatability:better than 0.2%.accuracy:better than 1%

3:signal output :one channel standard isolation RS485 output

One channel isolation 4-20mA or 0-20mA active output.

One channel OCT output(programmed between the pulse width(6-1000ms),default before leaving factory (200ms))

One channel isolation relay output,with positive,negative,net accumulation pulses and different alarm signals.

4:signal input: two channel three wire system PT100 platinum resistor input loop,to make heat meter has the function of displaying heat quantity.

Three channel 4-20mA input optional,accuracy:0.1%,has the ability to input the signals of pressure, liquid level, temperature and so on.

5::display:2*20 backlit LCD(Chinese and English optional)

6:operating:4*4 tactile keypad

7:other functions:automatic memory the positive,negative,net totaliser flow rate and heat quantity of the last 512 days,128 months,10years

Automatic memory the time of power on/off and flow rate of the last 30 times, realize to replenish by hand or automatically,read the datas through Modbus communication protocol.

8:protection level:mainframe:IP65, transducer:IP:68

9:transducer: clamp-on type,insertion type,in-line type.

Optional accessory:

1:clamp-on transducer(standard S2 style,standard M2 style,high temperature S2H,high temperature M2H)

2:insertion transducer(standard insertion B,cement insertion B)

3:in-line type transducer(hygienic style, Π style,standard style)

4: special shielded twisted pair cable

5:strap(applied with installation of transducers on cast iron,GRP,PVC,etc. that can not be welded directly).

■mainboard wiring map and outline size:

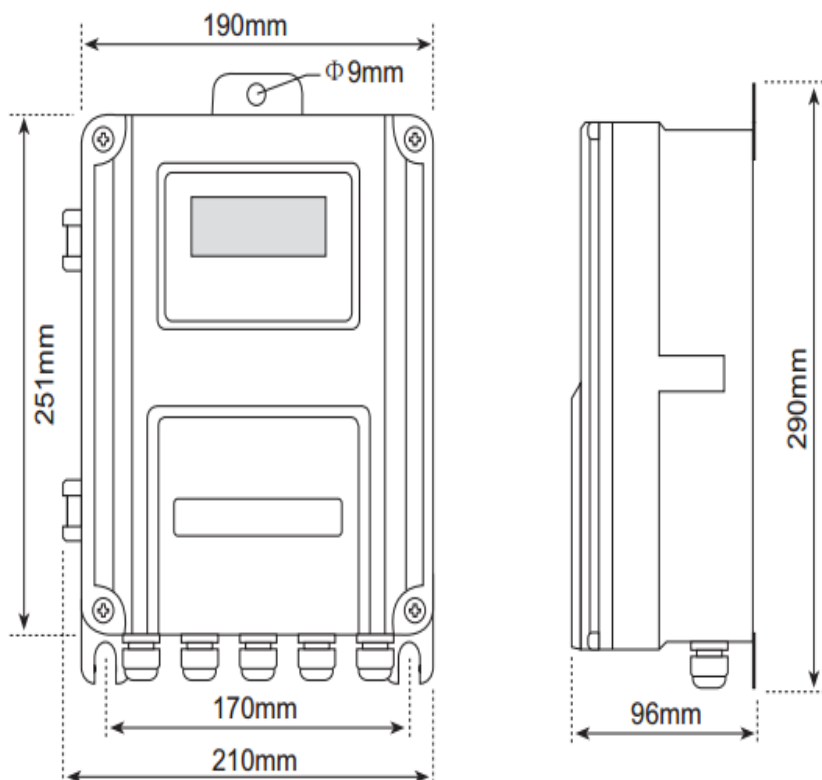

version mainboard

3 display and operation

§3.1.1 key function

The new PHI-100F series ultrasonic flow meter can respectively or at same time use 16 key keyboard monitor.

16 key parallel or serial port key board,including 10 digit keys,2 up/down arrow key,1 Menu key(M),1 enter key,1 arithmetic point key,1 backspace key. The keyboard can make users operate quickly and conveniently

4 key keyboard has 2 up/down arrow key,1 menu key(M),1 enter key(ENT),inputing digits,characters,and arithmetic point is by using up arrow key to input many times,the use of down arrow key is to move to next digit position.

For example :to use 16 keys keyboard.

0-9 and <-> are used to input digits or Menu number.

◀ key is used to left backspace or delete left character.

<▲/+> and <▼/-> are used to enter upper and lower Menu,when inputing digits,it equals to plus or minus key.

Menu key is used to visit Menu,firstly press this key and then press two digits keys to enter related Menu.for example,if to input outside pipe diameter,press Menu <1><1>. "11" is the address code of outside pipe diameter parameter.

<ENT>key is used to ensure the input digit or chosen content.the other function is to press this key to enter "modify" status before inputing parameters.

"bibi" sound of pressing keys of buzzer can be shut down by using M77 to choose 25 item.

§3.1.2 detailed information of Menu

flow rate/fl ow totalis er displa y	00	display instant flow rate/net totalizer,adjust the units in M30-M32
	01	display instant flow rate/instant flow velocity, adjust the units in M30-M32
	02	display instant flow rate/positive totalizer, adjust the units in M30-M32
	03	display instant flow rate/negative totalizer, adjust the units in M30-M32
	04	display instant flow rate/date time
	05	display heat flow rate/total heat quantity,adjust the units in M84 ,M88.
	06	display temperature input T1,T2
	07	display present battery voltage.(suitable to PHI16)
	07	display analogue input AI3,AI4
initial setup	08	display system error code
	09	display today net totalizer
	10	input outside perimeter of pipe
	*11	input pipe outer diameter,data range:0-18000mm
	*12	input pipe wall thickness
	*13	input pipe inner diameter
	*14	choose the kinds of pipe materials
	15	input sound velocity of pipe material
	16	choose kinds of liner
	17	input the sound velocity of liner
	18	input the thickness of liner
	19	input inner pipe wall absolute degree of roughness
	*20	choose kinds of fluids
	21	input fluid velocity
	22	input fluid viscosity
	*23	choose the types of transducers,including more than 20 types to use
	*24	choose transducer installation method
	*25	display transducer installation space
	*26	parameter solidifying and setup
	27	store and read installation parameters on installation point
	28	When signal set turning poor,keep last datas,choosing"yes"means when the signal turning poor,the flow meter display last correct measured datas.
	29	。 Input signal strength when the pipe flow is set to be empty.for example:inputing 65 means when the signal strength is lower than 65,the flow meter will think that there is no

		liquid in the pipe and display the flow value as zero.
flow	30	choose metric or imperial unit
	31	choose instant flow rate unit
	32	choose totalizer unit
	33	choosing the totaliser multiplying factor which function is to multiply totaliser data rang,normaly set it as x1
	34	net totaliser switch
	35	positive totaliser switch
	36	negative totaliser switch
	37	restore parameters setup before leaving factory and reset totaliser
	38	manual totaliser(the key to control on/off)
unit setup	39	choose operating language,including 8 kinds of different languages for international users to use
	3	setup the LCD display method,inputing 0 or 1 means regular displaying content.inputing 2-39 means automatically cycle displaying method,displaying the previous menu of 2-39,time interval is 8 seconds.when inputing accures ,displaying according to the inputing operation.when there is no inputing operation,it will automatically enter cycle displaying status.(detailed information in §3.1)
Choo sing setup	*40	damper coefficient
	*41	Input low flow velocity cutoff value
	42	Setup static zero point
	43	clear zero point setup and manually setup zero point,restore default before leaving factory.
	44	Set up zero point deviant by hand
	45	meter coefficient,rectification coefficient
	46	input Network address identification number (IDN)
	47	password protecting operation,after the meter was setup with password,only browse menus without any modification.
48	Input degree of linearity broken line rectification data.at most there is 12 segments broken line,used for users to rectify meter nolinear.	

	49	Network communication tester, on this window to visit the data transferred from upper computer to judge the problems arising during communication.
scheduled time output	50	Optional setup of data output at scheduled time, choose output content at scheduled time to print, more than 20 to select
	51	Setup output time at scheduled time
	52	Printing data flow direction control. By default, printing data will flow directly to the thermal printer hanging inside the bus. Setup printing data output to outside serial port (RS485 port)
AI5 setup	53	display analogue input AI5 (reserved for the PHI16 mainboard)
input and output setup	54	Setup of OCT totaliser pulse output, pulse width, range: 6 Ms-1000 Ms.
	55	choose current loop mode
	56	corresponding data to output of current loop 4mA or 0mA
	57	corresponding data to output of current loop 20mA
	58	Verification of current loop output. Applied to check whether current loop is normal or not.
	59	present output of current loop
	60	Date time and setup. The date time of the new flow meter is realized by CPU, when upgrading software, time will be slow, so after upgrading, recommend to adjust the date and time to display correctly
	61	Software version information and Electronic Serial Number (ESN)
	62	setup serial port parameter
	63	Communication protocol choosing (including compatible protocol choosing), two options, choosing MODBUS-RTU means using binary system MODBUS-RTU protocol. Choosing MODBUS-ASCII+previous protocol means using ASCII protocol, at this time can support several protocols simultaneously, including MODBUS-ASCII, previous 7 version protocol, FUJI protocol, Meter-BUSx protocol etc.

	64	analogue input AI3	By inputing measuring range ,the flow meter will turn current signal into data range users need,so display related analogue input that corresponding to physical parameter data.
	65	Analogue input AI4	
	66	Analogue input AI5	
	67	Setup frequency range of frequency output signal.frequency signal output represent instant flow rate value by signal frequency value.default:0-1000Hz , max-range:0-999Hz.output frequency signal by special frequency output unit.	
	68	setup lower limit flow of frequency signal output	
	69	setup upper limit flow of frequency signal output	
	70	LCD backlit control	
	71	LCD contrast ratio control	
	72	Work timer,logging work time of the meter by unit of second.it can reset.	
	73	setup lower limit flow of frequency signal output	by setuping the lower and upper limit of alarm,confirm a range,when actual flow is over the range set in this window,then create a alarm signal output.alarm signal can be transferred to outside by setuping OCT or relay.
	74	setup upper limit flow of frequency signal output	
	75	LCD backlit control	
	76	LCD contrast ratio control	
	77	beeper setup options	
	78	setup Open Collector Transistor output(OCT) output options	
	79	setup relay(OCT2) output options	
	80	choose input signal of batch controller	
	81	batch controller	
heat	82	day/month/year totaliser,check the flow rate and heat quantity of the totalisers	

quantity measuring	83	。 Automatically replenish flow switch during the period of power off,default status:off.this function is not available under special conditions.
	84	Choosing heat quantity unit, 0.Gj(default) 2.Kcal 3.Kw 4.BTU (imperial unit)
	85	Choose temperature signal origin,if choosing inputing temperature signal by AI3,AI4,then need temperature transmitter that can output 4-20mA current signal.
	86	heat capacity,default: GB-CJ128 enthalpy potential method. Temperature difference method is available also.
	87	heat quantity totaliser switch
	88	Heat quantity multiplier factor.
	89	display present temperature difference and setup temperature difference sensitivity.
	80	Options of installation of heat meter on supply water pipe or return water pipe
diagnosis	*90	Display the signal strength and signal quality
	*91	Display the transit time ratio
	92	Display the calculated fluid sound velocity .
	93	Display the total transit time and the delta time
	94	Display the Reynolds number and the pipe coefficient
	95	Display positive,negative heat quantity totaliser,start cycle display function.
added menu windows	+0	Display the time of power on/off and flow rate
	+1	Display the total working time of the flow meter
	+2	Display the last time of power off.
	+3	Display the flow rate of last power off
	+4	Display total times of power on

	+5	Scientific calculator
	+6	Setup threshold value of fluid sound velocity
	+7	Net totaliser of this month
	+8	Net totaliser of this year
	+9	Operating time with trouble(including power off time)
hardware adjustment menu windows	.2	store static zero point
	.5	setup threshold value of Q value
	.8	max instant flow rate of this day and this month
	.9	serial port testing window with CMM direct output
	-0	circuitry hardware parameter adjusting entrance(only inputing password to enter following windows)
	-1	4-20mA current loop calibration
	-2	AI3 inputing calibration of analogue input 4 mA
	-3	AI3 inputing calibration of analogue input 20mA
	-4	AI4 inputing calibration of analogue input 4mA
	-5	AI4 inputing calibration of analogue input 20mA
	-6	AI5 inputing calibration of analogue input 4mA
	-7	AI5 inputing calibration of analogue input 20mA
	-8	zero point setup of PT100 at lower temperature(<40°C)
	-9	PT100 setup zero point at higher temperature (>55°C)
-A	PT100 standard calibration at 50°C	
-B	PT100 standard calibration at 84.5°C	



* means common used menus, red color means new added or changed functions, blue color

means the menus related with heat quantity measurement

§3.1.3 Work parameter solidification of the flow meter and option introduction

The new PHI-100F has 3 work parameter areas, respectively called: present parameter data block, solidification parameter data block, user pipe parameter data block.

Present parameter data block is built in internal RAM, if outside power supply and spare battery are off together, then lost the present work parameter.

Solidification parameter data block is built in internal FLASH, normally it will not lose.

for long time stable work application, after setting up all the work parameters, using the function of solidification parameter in M26 to solidify the parameter data block in RAM to FLASH, and setup recalling the work parameter in FLASH to present parameter data block when power on for each time. for the application of modifying the parameters frequently (like portable flow meter), please choose "0. use parameter in RAM area" option in M26. when power on, then keep the parameters in RAM to use directly. if the data block in RAM exists verification errors, then it will go on to recall the work parameter in FLASH

User parameter data block is able to store 9 sets commonly used pipe parameters. the access operation is in M27

§3.1.4 Zero point setup and zero point solidification

The new transducers have a "zero point", its meaning is when fluid flow velocity is zero, the flow meter will display a non-zero flow value. this value will repeatedly add to the indicating value of the flow meter under any flow velocity, for example, assume that the zero point is 1 m³/h, present flow velocity is 10 m³/h, then the indicating value of the flow meter is 11 m³/h. so newly install or change transducers, normally need to adjust zero point and log zero point value, minus this zero point value

from indicating value for calculating later.

To adjust zero point in M42.but the zero point value after adjusting is only stored in RAM parameter area temporarily ,is not solidified in FLASH.if the spare battery is off or choosing the solidification parameters in FLASH as work parameters when power on,the zero point value will loose.in order to keep the zero point value forever,users must use M.2 to store the zero point after adjusting zero point for each time.

§3.1.5 Factory use the scaling factor solidification

Same as the principle of storing zero point value,factory scaling factor need be solidified after calibration before leaving factory.it is in M.1 ,use two grade passwords to visit.

§3.1.6 analogue calculating function application

When setting pipe diameter is zero,display the instant flow velocity :1.2345678m/s(4.0504ft/s),instant flow rate=0 ,and display “R”status.inputing a set value in M44 can obtain changable totaliser output.using this function to achieve the function of test of the flow meter and adjustment of network software without connecting transducers.

§3.1.7 Analogue input interface as digit input interface method and introduction

The new PHI-100F series' analogue input interface can work as digit input interface ,but note that the loop input current should not be over 20 mA.when outer digital quantity voltage is 5V,you should series connect a 1k resistor in return circuit.if the digital quantity voltage is 12V,then series connect a 2k resistor.

§3.1.8 Introduction of serial peripheral extension interface

Serial peripheral extension interface is like USB interface,it has input,output,power supply+,power supply- ,totally 4 lines.for each measuring,it can output instant flow,instant heat flow,positive total,4-20mA value,frequency value and printing data etc.different function model can take down data according to requirements.the serial bus use 4800 baud rate.

§3.1.9 Realize medium identifying function

For example:application in mixture fluid of oil and water,to judge the medium in pipe is water or oil,you could input lower limit of water flow in M+6,it is 1400m/s for this example.when the fluid flow velocity measured by the flow meter is lower than 1400m/s,a internal signal created,used to indicate that the fluid is another medium.this signal can be output by OCT or read by MODBUS protocol.but you assure that the two fluid flow velocity can not exist overlap.

§3.2 The flow meter restore to factory default

If like to clear all set parameters to restore original factory default,only use serial port or parallel port keyboard to enter M37 to click <·><◀>,so can restore default set parameters before leaving factory. Attention:except of first installation,normaly not use this function.

4.transducers installation

§4.1 Unpack checking



:Check whether the spare parts comply with packing list,enclosure is broken or not during transportation?did screw drop?connecting line is loose or not?if have questions,pls cotact factory.

§4.2 Power supply and cable

When users place an order,pls inform factory what kinds of power supply is needed,normaly the power supply of the flow meter have following options:

One : AC85~264V

second: DC24V or DC8~36V



:Draw operator attention:if connect the mainframe powered supply by direct current or low voltage AC (DC8-36V) with AC220V,the flow meter will be destroyed.

Transducers signal cable of PHI-100F series ultrasonic flow meter adopts high frequency special shielded twisted pair cable.because sending and receiving circuit adopts balanced transmitting and balanced receiving principle.so to increase the anti-interference function,little signal consumable ,ensure the device work well in longer term.so the special signal cable supplied by factory is the best choice for you.if using coaxial shielded radio frequency cable or poor quality twisted pair cable,it could lower accuracy and the function of the device.when there is bigger interference signal from outside,the device could not measure normally.

§4.3 Required installation condition

Installation of The new PHI-100F series is the easiest and convenient way in the installation of all flow meters,just choosing a suitable measurement point,input the pipe parameters of this pipe point to the flow meter,then fix the transducers on the pipe.

§4.3.1 choosing measurement point

To ensure measurement accuracy and stability,the installation point of tranducers should be on the straight pipe full of well distributed fluid(when installing,the pipe must be full of liquid),comform to following principle:

1.Pipe must be full of liquid that is uniform and easy to travel the ultrasonic beam(vertical pipe or

horizontal pipe)

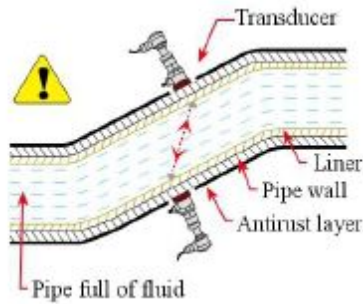

2. Upstream transducer should be installed at the place where the upstream length of the straight pipe is at least $10D$ and the downstream length is at least $5D$ where install the downstream transducer, so the pipe length should be straight without any valve, pump, angle head, D stands for pipe outside diameter.

The installation point should stay away from valves, pump, high pressure current, transformers interference source etc.

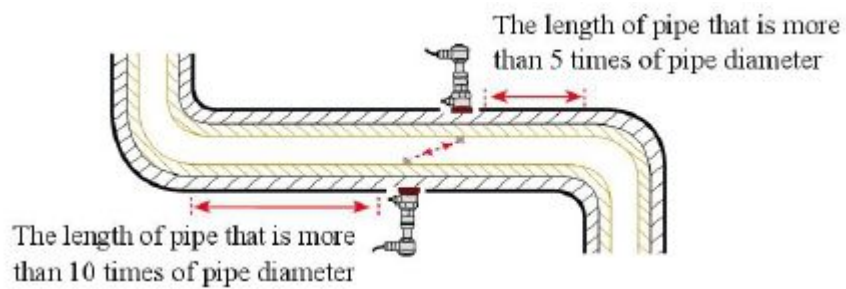

3. Avoid to install on the highest point of pipe system or vertical pipe with free exit (flow down)

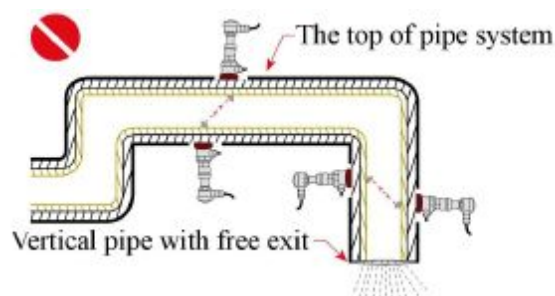

4. For the opened pipe or half full pipe, the transducers should be installed on U pipe.

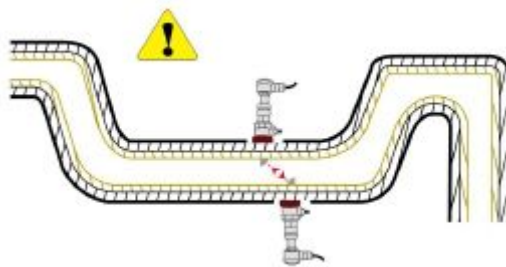

5. The temperature and pressure on the installation point should be within the work ability of the transducers.

6. Pay more attention to the pipe scaling in inner pipe wall, do best to choose the pipe without scaling to install, if it is impossible, then consider the scaling as liner to achieve better accuracy.

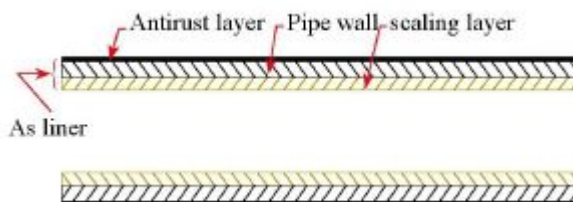

7. The two transducers must be installed in horizontal direction to pipe axis plane, within $\pm 45^\circ$ of axis line horizontal plane, to prevent bubbles or not full in upper pipe or sediment in down side of pipe to influence transducer measurement normally. If there is space limit of installation that could not install horizontal symmetry, then install the transducers vertically or dip angle under the condition of no bubbles in upper parts of pipe.

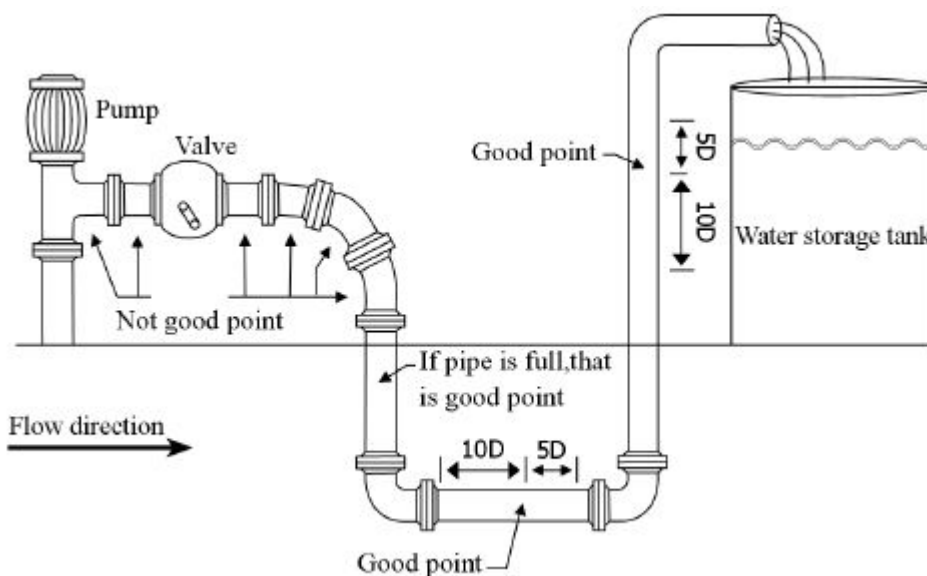

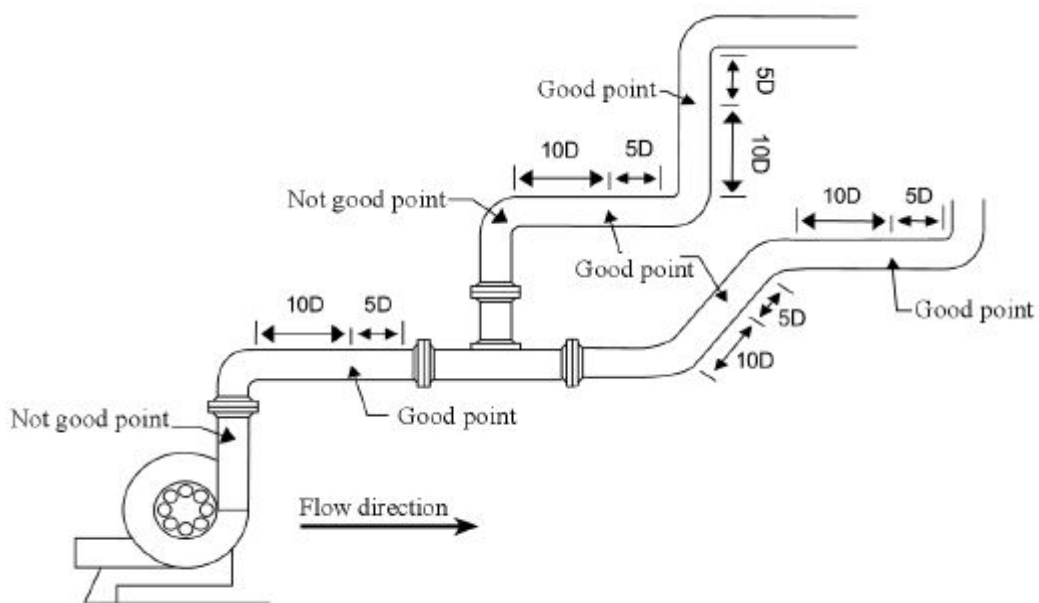

§4.3.2 instrument well construction requirements

If need to install transducers in instrument well,there must be enough installation room,convenient for people to stand up to work,distance between pipe wall and well wall is at least above 550mm,width is more than $(D+550*2)$ mm,cement pipe width is more than $(D+700*2)$ mm,instrument well axial width L is more than $D+1200$ mm.when installing transducers,avoid the place of flange,welding line,reducing,do best to install transducers in the range of $\pm 45^\circ$ of horizontal position of pipe axis.

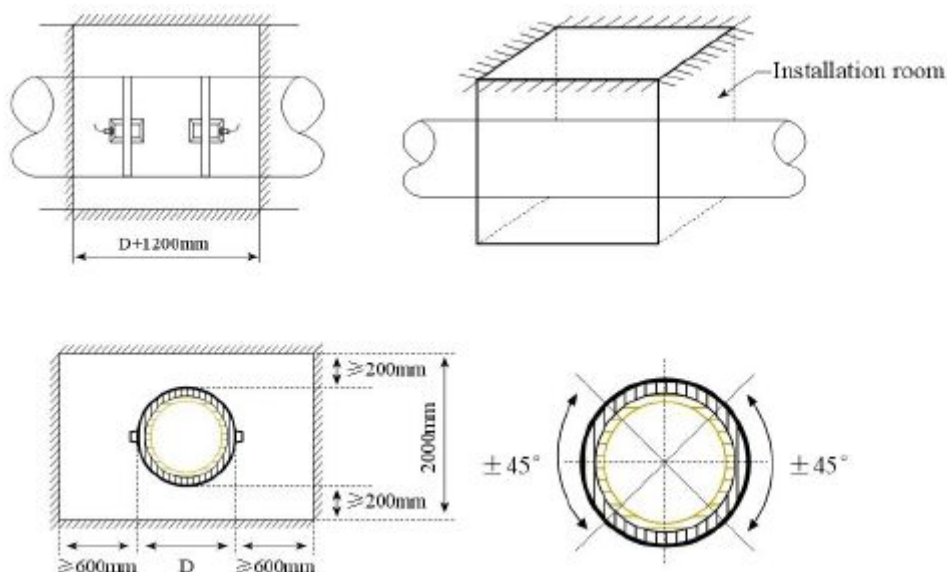



Attention: 1, Do best to install transducers in the range of $\pm 45^\circ$ of horizontal position of pipe

axis .

2, Connect the mainframe enclosure with ground.

3, Avoid the installation place of flange, welding line, reducing

4, Enough installation room, convenient for people to stand up to work

§4.4 Quickly input pipe parameter steps:

Need input following parameters when normally measuring

1. pipe outer diameter
2. pipe wall thickness
3. pipe material
4. liner parameter (if has liner, then include liner thickness and sound velocity)
5. fluid types
6. transducers type (mainframe can support many kinds of

transducers)

7. transducers installation method

8. solidification parameter

§4.5 Clamp on type transducer installation method

Before installation, choose density pipe to install transducers, and clean the installation area, clear away

rust, paint, anti-rust layer, it is the best to use angle grinder to polish, use cleaning cloth with alcohol or

acetone to clear oil and dust, coat enough couplant around the center of installation area, attach the

transducers on the pipe and fix it without air bubbles or sand between transducers and pipe wall.



High temperature S2H type



High temperature M2H type

transducer	Standard S2 type	Standard M2 type	Standard L2 type	High temperature S2H type	High temperature M2H type
Suitable pipe diameter	DN15-DN100	DN50-DN700	DN300-DN6000	DN15-DN100	DN50-DN700
Fluid temperature	0°C~70°C	0°C~70°C	0°C~70°C	0°C~160°C	0°C~160°C
Outer size	45×30×30mm	60×45×45	80×70×55	90×85×24	90×82×29
quality	75g	250g	650g	94g	150g



Remarks:users input transducers parameters by yourself

§4.5.1 Installation space

Installation space of clamp on type transducer is inner edge distance of the two transducers(face to face),after inputing the required parameters in Menu,check the display on M25,that is the installation space.

§4.5.2 Installation method

The method has 2 kinds: V method,Z method

Normaly,V method is suitable to the pipe diameters within the range: DN15-DN200mm .when using V method can not measure the signal or the signal is poor,try to use Z method that is suitable to the diameters are more than DN200mm or measuring cast iron.

V method(commonly used method)

Normally, V method is standard installation method, convenient to use with precise measurement, when installation, the two transducers horizontally align, its centre line is horizontal with pipe axis line, suitable pipe diameter range to measure is DN15mm-DN400mm.

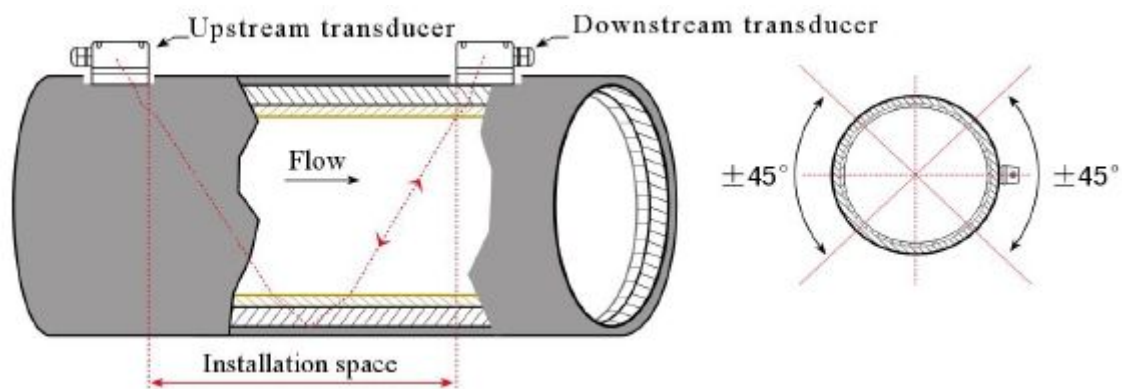

Z method (the most commonly used method)

When the pipe diameter is wide, or there are suspended matters in fluid, too thick scaling or liner inside pipe inner wall, that can make the flow meter can not work normally and signal poor by using V method installation, so need to use Z method to install, its features are direct transferring without reflection (called single sound path), little signal attenuation.

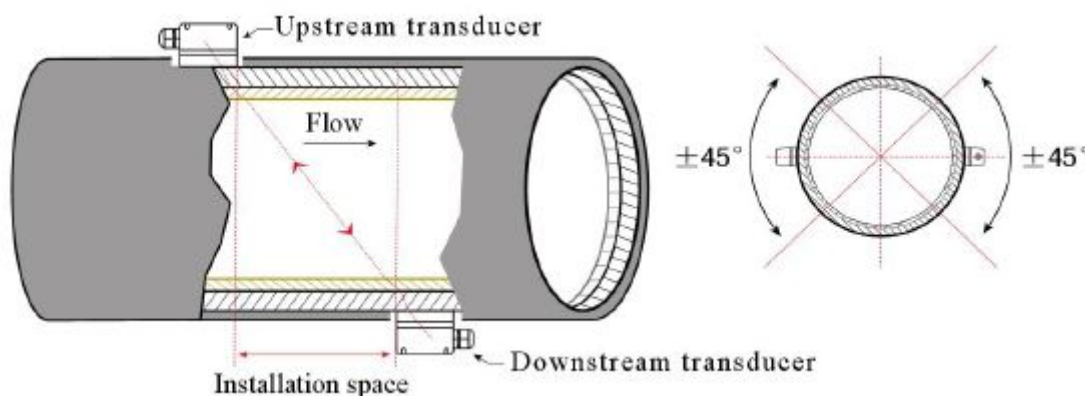

Attention: 1, when installation, it is a must to clear the pipe area where to install transducers, showing metal color

2, shield line of ultrasonic signal cable can not be connected, but not short circuit with positive and negative pole (red and black line)

3,after transducers are connected with circuits,must apply enough sealant to prevent water in.

4,after covering the transducers,must screw and lock tightly the hole for shield line of transducers to prevent water in.

5,use strap(stainless steel band) to fix on the center part of transducers,to make it weighted uniform,no moving.

6,apply enough couplant around the area , so that transducers touch pipe to prevent air,sands,rust in,that influence the beam transferring.

§4.6 Insertion type transducer installation method

The new PHI-100F series insertion type transducer incorporates the advantages of clamp on type and in line type transducers,its features:

Transducers can be installed directly on pipes of carbon steel or stainless steel by welding; while for those pipes of materials like cast iron, glass fiber reinforced plastic, PVC and cement which cannot be welded directly, special straps should be used for installation. For those users who are in similar situation, please inform us of the precise outside diameter of the pipe to be installed to prevent leakage.



	insertion B type (insert directly)	Insertion B type (for sement pipe)
Suitable diameter	Above DN80mm	Above DN80mm
Installation room	≥550mm	≥700mm
Fluid temperature	-40℃-160℃	-40℃-160℃
Transducer material	316L stainless steel	316L stainless steel

§4.6.1 Installation tools

Special hole-drilling positioning tools made by our company (Hipeak Instrument Development Co., Ltd), 400w handle rotary drill (high speed adjustable is preferable), spanner and screwdriver are needed for installing insertion transducers.

§4.6.2 Installation space

Insertion style transducers spacing is calculated based on the distance between the centers of the two transducers along the pipe axis. The space will be shown on menu M25 when necessary data are put into the menu, and the transducers should be installed according to this space.

§4.6.3 Installation method

There is only one way to install insertion style transducers which is called Z-method installation and can be applied for all pipes which diameter is more than DN80mm.

§4.6.4 Locate the installation point

Input the pipe parameters on the mainframe, the installation space L ($L = \text{inside diameter} - 9.113\text{mm}$) will be calculated. (the two sensors must be located in the same axis plane), the installing space L should be the distance between the centers of the two sensors horizontally.

A. Making a fixed position paper: take a $4D$ (D refers to the pipe inner diameter) long and 200mm (or D) wide rectangular paper (according to actual situation on spot, the paper tape can also be replaced by moisture-and-corrosion resistant materials), and draw a line about 100mm from the edge;

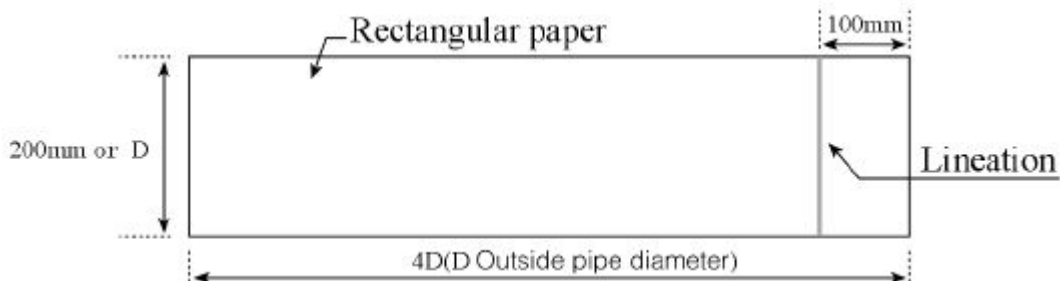

B. Wrap the fixed position paper on the cleaned surface of the pipe, making sure that the two paper sides are overlapping and aligned and thus the line drawn may be parallel with the pipe axis;

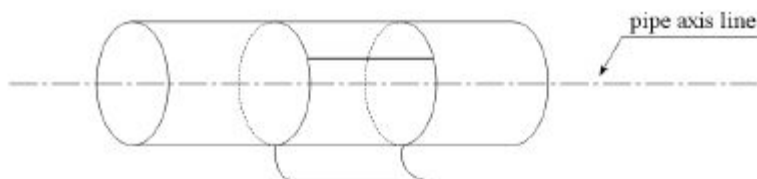

C. Extend the line on the fixed position paper to the pipeline and the cross-point

between the vertical side of the fixed position paper and the extended line is A

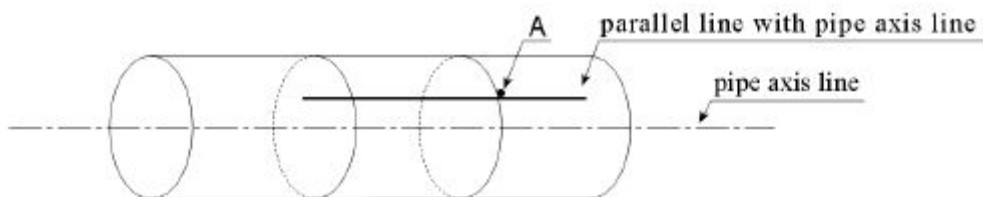

D. Starting from A and along the edge of the position paper, the length of half of the pipe perimeter is measured and the cross point is C; then draw a line at C to be parallel to the axis (that is, to be parallel with the line on the position paper);

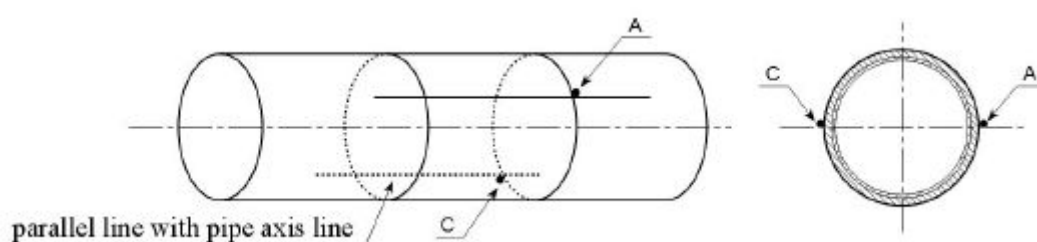

E. Removing the fixed position paper and starting from C, the installation space L should be measured along

the line, draw on the pipe, the point is B. Thus, A and B are the points where the transducers are to be installed. For example, L=280mm. Then two bases of ball valves should be welded respectively on A and B, making sure the centers of bases overlap A and B respectively.

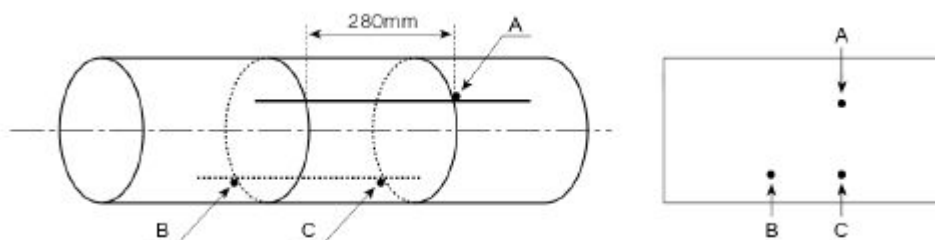

§4.6.5 Welding the base of the ball valves

For pipes that can be welded (such as steel and stainless steel, etc.), just weld the base on the pipe (Stainless steel pipe should be welded to stainless base, please indicate in your order). Before welding, the rust and paint on the section where the sensors are to be installed shall be cleaned up by using an angle grinder, and the oil dirty and dust should be cleaned by using acetone or alcohol. to prevent water leakage,so the work of welding is very important, making sure the centers of bases overlap A and B respectively,no air bubbles.

For pipes which material cannot be welded directly (such as cast iron and cement, etc.), special hoops

(with airproof rubber pads) should be used. The bases of the ball valves have been welded on the hoops.

These hoops are directly fixed on the pipe and make sure that the centers of the ball valves overlap A and B respectively. Finally, the ball valves should be closely fixed on the bases welded on the hoops to prevent water leakage.

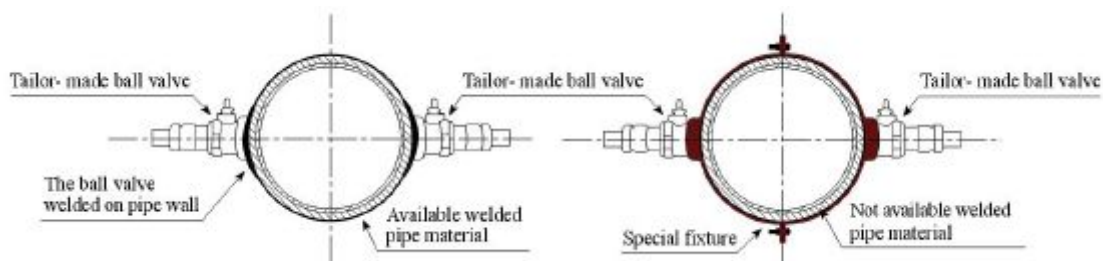

§4.6.6 hole-drilling

Connect the sealed sheath of the hole-drilling machine and the outer screw thread of the tailor-made ball valves, screw tightly, open the ball valves, push the drill pipe to touch the outer surface of pipe; then the drill pipe shall be locked to the handle rotary drill before the drill is switched on. During drilling, the drill machine should work in a low speed to avoid sticking or even drill bit breaking. After drilling through pipe wall, pull back the drill pipe until the head of drill bit reach the ball valves spool, turn off the ball valves, take down hole-drilling machine.

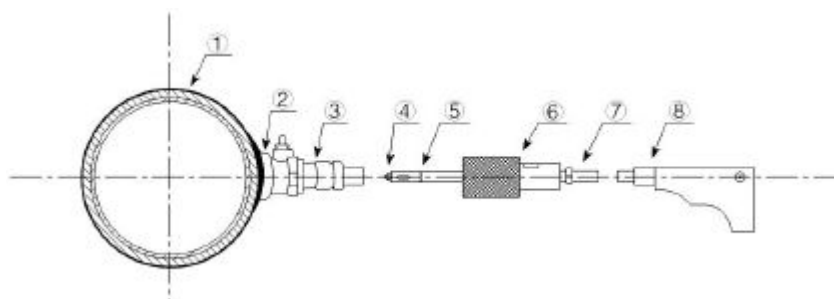

- ①Pipe
- ②Ball valve base
- ③Tailor-made ball valve
- ④Locating drill pipe bit
- ⑤19 super hole cutter
- ⑥Seal gland
- ⑦Drill pipe
- ⑧Hole-drilling machine

§4.6.7 inserting the transducers

screw the screw nut to a position under the bottom of the transducer and screw the transducer through the ball valve to ball valve spool. Open the ball valve and continue to screw the transducer until the head of transducer passes the inner wall of the pipe. Before the wires are connected, the angle of the transducer should be adjusted to make sure that the head of two transducers can be in face to face position so as to send and receive the signals properly (the hole for line of two transducers should be upward or downward at same time). and then fix the screw nut, connect the wires, use silicon rubber to seal the connection place.

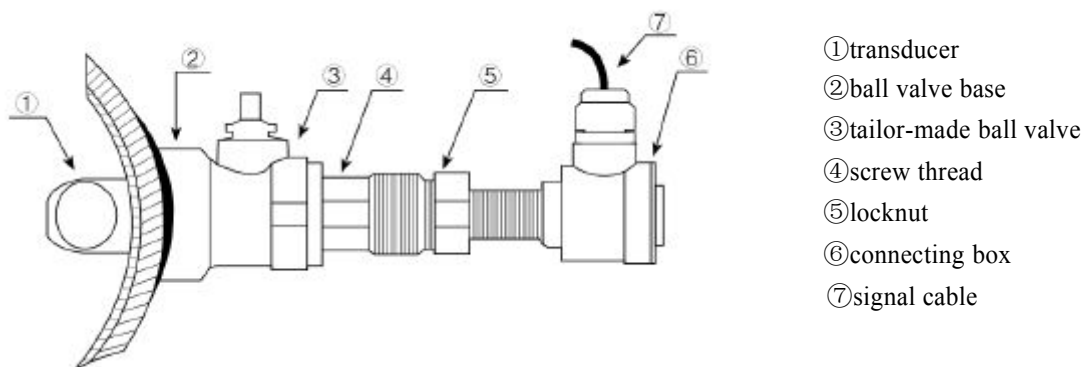

§4.6.8 Length calculation of the part of transducer into the pipe inner wall:

Insertion style transducer is made of stainless steel by casting. As the transducer's length A and the pipe wall's thickness B are known, and the length part of transducer left outside the pipe can be measured, the length of the inner part of the transducer can be calculated through the formula: $L=A-B$, $C=0$

Note: the length A of different types of transducers are: Standard insertion type B: A=170mm; Standard insertion type C: A=220mm, and Cement insertion type B: A=310mm.

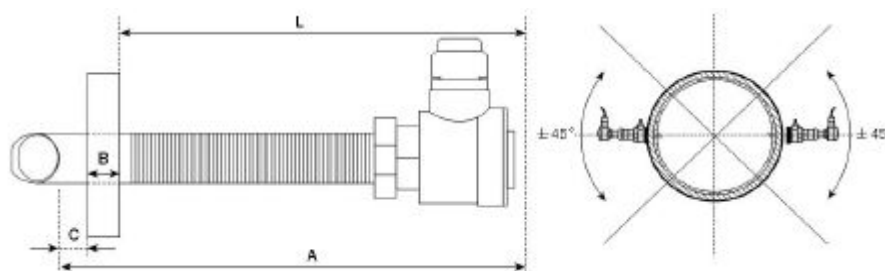

§4.6.9 wiring

After wires being connected, screw the nut on the hole for wires (do not lose packing seal), at last, screw seal cover tightly to prevent water leakage.

§4.6.10 Transducer wiring picture

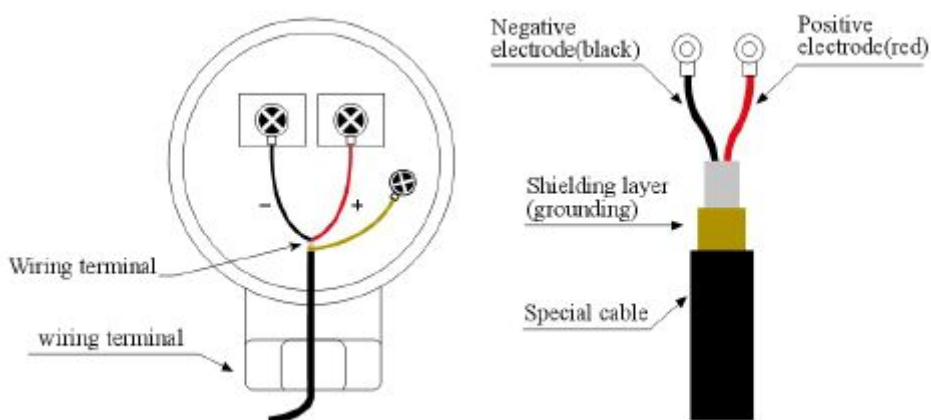

§4.6.11 Maintenance

The maintenance is easy,exchange the old transducer with the new transducer according to the reverse process.



Attention:

- 1 during the process of welding the base of the ball valves,avoid the phenomenon of slag inclusion,sand hole,water leakage.
 2. The bases of the two ball valves should be welded on the same axis plane to prevent poor receiving of ultrasonic waves;
 3. after The holes having been drilled through, the impurities such as iron filings in the ball valve should be cleaned up so that the transducer probe may not get stuck or its thread get adhered;if so,still to screw hardly,and do not stop,the transducer will be destroyed and not work well.
 4. Make that the ultrasonic emitting surfaces of the two transducers are face to face (that is, the holes for wires are in the same direction and either upward or downward);
 5. After the transducer is installed, the screw mut should be screwed tightly to avoid transducer move.
- The seal cover should be screwed tightly to prevent water after wires being connected..

§4.7 In-line type transducer installation method

In-line type transducer of new PHI-100F series is characterized by easy installation and high-accuracy measurement. When ordering, customers need to provide the actual parameters of the pipe. The parameters of the transducer have been put into the flowmeter before leaving factory and there is no need to input them when installing.

There are two types of pipe transducers for selection:

1. π-type transducer(DN15-DN40MM)
2. Standard pipe transducer(DN50-DN1000MM)



Parameters	π-type transducer	Standard pipe transducer
Material	Stainless steel	Carbon steel(stainless steel is optional)
Pipe size	DN15-DN40MM	DN50-DN6000MM

Connection:	Flange type	Flange type
Application of temperature	-40℃ ~ 160℃	
Protection class	IP68(can work in water, and water depth≤3 meter)	
Rated pressure	please refer to following table	
dimension	please refer to following table	

Nominal diameter(m m)DN	Rated pressure (Mpa)	π-type	Standard-pipe	Flange dimension(mm)					
		L1	L2	D	D1	D2	f	N-Φ	Flange thickness
15	2.5	320		95	65	45	2	14×4	14
20		360		105	75	55	2	14×4	16
25		390		115	85	65	3	14×4	16
32		450		140	100	76	3	18×4	18
40		500		150	110	84	3	18×4	20
50	1.6		200	160	125	100	3	18×4	22
65			200	180	145	120	3	18×4	24
80			225	195	160	135	3	18×8	24
100			250	215	180	155	3	18×8	26
125			250	245	210	185	3	18×8	28
150			300	280	240	210	3	23×8	28
200			350	335	295	265	3	23×12	30

250			450	405	355	320	3	25×12	32
300			500	460	410	375	4	25×12	32
350			550	520	470	435	4	25×16	34
400			600	580	525	485	4	30×16	38
400	1.0		600	565	515	482	4	25×16	30
450			700	615	565	532	4	25×20	30
500			800	670	620	585	4	25×20	32
600			1000	780	725	685	5	30×20	36
700			1100	860	810	775	5	24×25	32
800			1200	975	920	880	5	24×30	32
900			1300	1075	1020	980	5	24×30	34
1000			1400	1175	1120	1080	5	28×30	36

§4.8 check installation of transducers

After the completion of transducer installation, the user should check the following items to see whether the installation is suitable, whether the received ultrasonic signal is correct, enough strong, that could make the meter work normally and long time running. By checking the receiving signal strength S, the signal quality Q value, the delta time, , the transit time ratio R to assure whether the installation point is good or not. Normally, apply couplant on the transducers and attach them on the pipe, so can obtain measurement results, but it is better to check followings to ensure the flow meter is working properly and the results are reliable and accurate.

§4.8.1 Signal Strength

Signal strength S (display on M90) indicates strength of sending and receiving signals from upstream transducer and downstream transducer by a 3-digit number. [00.0] means there is no signal detected, and [99.9] refers to the maximum signal strength that can be detected. When installation, do best to adjust the position of transducers and check whether the couplant is sufficient, to make sure to gain the strongest signal. Although the instrument works well when the signal strength ranges from 60 to 99, when the signal strength is too low, you should check the installation position, installation space, whether the pipe is suitable to install or change to install by Z method. Stronger signal strength should be pursued, because a stronger signal means a stable measurement results, long and reliable running..

§4.8.2 Signal quality(Q value)

: Signal quality is indicated as the Q value (display on M90) that represent the receiving signal is good or not, PHI-100F series use 00-99 digits to represent signal quality. 00 represent the worst signal, 99 represent the best signal, normally the signal quality should be above 60. the reason of poor signal quality could be big interference, or worse installation of transducers, or using bad quality, not professional signal cable. normally, to adjust transducers repeatedly, check the couplant that is enough or not, until the signal is better.

§4.8.3 Total transit time,delta time

The total transit times (or traveling time) and delta time are displayed on menu window M93,they can display whether the installation is suitable or not, They are the basic two parameters for the flow meter's internal measurement and calculation,. When the data of delta time fluctuates too much,the showed flow rate and velocity will change quickly,under such condition,it means the signal quality is not good,perhaps the conditions of pipe is not good,not suitable installation of the transducers,or wrong parameters input.normaly the fluctuation of delta time is less than $\pm 20\%$.but when the pipe diameter is too small or lower flow velocity,the fluctuation of delta time **may be higher.**

§4.8.4 Transit time ratio



Transit-time ratio (visit on M91)is usually used to check whether the transducer installation space is good .If the pipe parameters are correct and the transducers are installed properly, the transit time ratio should be in the range of $100\pm 3\%$.when the ratio is over the range,you should check,

- a) If the entered pipe parameters are correct?
- b) If the actual space of the transducers is the same as or close to what shown on window M25.
- c) If the transducers are installed properly in the same axis plane of pipe?
- d) If the mounting location is good, if the pipe has changed shape, or if the pipe is too old (i.e., too much corrosion or liner inside the pipe)?
- e) If there is any interference source around the flow meter?

§4.8.5 Note the following questions when installing

- 1, input pipe parameters must be correct,conform to actual facts,otherwise the flow meter will not work.
- 2,when installing clamp on type transducers,apply enough couplant to make the transducers attach on the pipe,check the signal strength and signal quality displayed on the screen while moving the transducers around installation point to receive the best signal and signal quality.the diameter of pipe is more wider,the range of moving transducers is more larger.then ensure whether the installation space is the same with that on M25,whether transducers are installed in the same axis line of pipe.if the signal strength is 0.00,that means no receipt of ultrasonic beam,check whether the input parameters are

correct or not, choosing installation method is correct or not,whether the pipe is too old,liner is too thick,is there fluid in pipe? the space is too near valves,angle head?too many air bubbles in fluid?if not these reasons,still no signal,so have to try another point,or use insertion type transducers.

3,ensure whether the flow meter work normaly:signal streghth is bigger,signal quality is higher,the displayed flow rate is more reliable,the meter can work for long time.if there is too bigger environment electromagnetic interference or lower receiving signal,then the flow rate displayed is poor,not be able to work normaly for long time.

4,after installation,enter M26 to solidify parameters,power on again,check results are correct or not.

5. Troubleshooting

PHI-100F designed perfect self-diagnosis function.The errors are displayed on the upper right corner of the menu window via identification code in a timely order. Display orderly all the existing errors on M08

Hardware self-diagnosis is conducted every time when power is on. Some errors can even be detected during normal operation. For those errors undetectable due to incorrect settings or improper testing

conditions, the flow meter will also display useful information to help the user to quickly debug the error and solve the problems according to following listed methods.

Displayed errors of PHI-100F have two kinds:one is circuit hardware errors information,arising possible problems and solve method can refer to table 1.if finding problems when power is on,and in the state of measuring,it will display “* F”on the upper left corner of screen.power on again,check the displayed information,adopts measures according to following table.if the problems still exist,contact manufacturer. The other is error information about measurement.refer to table 2.

Table 1. Hardware self-diagnosis errors and solutions after power on

LCD display information	Causes	Solution
ROM verification Error	* ROM operation illegal / error	* Contact the manufacturer.
Logger reading error	* Stored parameters are wrong	*power on again/contact the manufacturer.
System logger error	* System stored data area has error	*power on again/contact the manufacturer.
Measuring circuit hardware error	* Sub-CPU circuit errors	*power on again/contact the manufacturer.
Cpu clock speed error	* System timer has errors	*power on again/contact the manufacturer.
Date time error	* System date and time are wrong	* reset date and time

No Display. Erratic or Abnormal Operation	* Problem with wiring	* check wiring connections.no influence of measuring normaly
No response to key pressing	* Keypad is locked * Bad plug connection	* input password to unlock keyboard,or check wiring connections,no influence of measuring normaly

Table2. Working status errors code causes and solutions

code	M08 displaying	causes	solutions
*R	system work normaly	* normal system	
*J	Circuit Hardware Error	* Hardware problem	* Contact the manufacturer
*I	No Signal	* Unable to receive signal * Loosen contact or not enough couplant between transducer and pipe surface. * Transducers installed improperly * scaling on inner pipe wall is too thick. * new changed liner	* Make sure the transducer is in tight contact with pipe surface, the couplant is enough . * Polish the pipe surface and clean the pipe surface. Clear paint,rust. * Check original installation parameter settings * Clear the scaling or change the pipe with thick scaling,normaly change to another measurement point that has little scaling,the meter can work normaly. * Wait until the liner has been solidified and then test.
*H	lower signal strength received	* lower signal * causes are the same with code "I"	* solutions are the same with code "I"。
*H	poor signal quality received	* poor signal quality * include above all caused	* include above all solutions
*E	The current of Current Loop is Over	* 4-20mA current loop output overflow 100% * Improper settings for current loop output .	* Check current loop settings on M56. or Confirm if the actual flow rate is too high.

	20mA (not influence the measurement if not using current output)		
*Q	Frequency Output is Over the set value(not influence the measurement if not using frequency output)	* 4-20mA current loop output overflow 120% * Improper settings for current loop output .	* Check frequency output settings(refer to M66-M69). or Confirm if the actual flow rate is too high.
*F	Listed in table 1	* find problems when power on and self-diagnosis * permanent hardware errors	* power on again,check the information showed on screen,handed according to table 1,if not solved ,contact manufacturer. * contact manufacturer.
*G	Adjusting Gain >S1 Adjusting Gain >S2 Adjusting Gain >S3 Adjusting Gain >S4 (displayed on M00,M01,M02,M03)	Instrument is in the progress of adjusting the gain to prepare the measurement. If stopped at S1or S2 or switched between S1 and S2,that means the too lower receiving signal or not good wave.	
*K	Empty pipe ,setup in M29	no liquid in pipe or wrong setup.	if there is liquid actually,input 0 value in M29



Attention:the codes of *Q,*E displayed do not affect measurement,only means current loop

and frequency output have problems