

PVC Valve

Threaded Connection, Schedule 80, 150 WOG

T-701

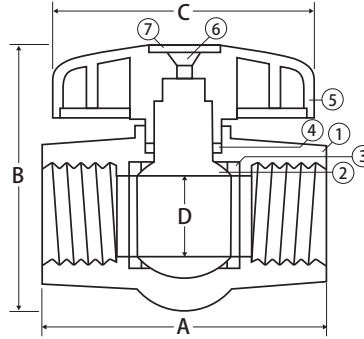

FEATURES

- NPS Connections
- 100% Tested
- Minimal Pressure Drop/Turbulence
- Large Ports for Greater Flow
- Corrosion Resistant PVC Material
- Wetted Surfaces Contain Less Than .25% Lead Content

CERTIFICATIONS/APPROVALS

- NSF 61-8 Certified
- NSF 61 - Annex G
- NSF 372
- NSF/ANSI 14 (1/2" - 2")
- ANSI B1.20.1
- ASTM F1970

PRESSURE/TEMPERATURE RATING

Max Service Temperature 140°F, 150 PSI @ 73°F Continuous
Min Temperature 41°F

MATERIALS

No.	Part	Material
1	Body	UPVC
2	Ball / Stem	UPVC
3	Seat (2)	EPDM
4	O-ring	EPDM
5	Handle	ABS Plastic
6	Bolt	Steel - Zinc Plated
7	Cap	ABS Plastic

DIMENSIONS

Part No	Size	A	B	C	D
210-203	1/2"	2.95	2.52	2.76	0.55
210-204	3/4"	3.24	3.04	2.98	0.79
210-205	1"	3.81	3.28	3.54	0.98
210-206	1-1/4"	4.33	3.70	3.54	1.18
210-207	1-1/2"	4.83	4.27	4.39	1.42
210-208	2"	5.54	5.19	5.50	1.83
210-209	2-1/2"	7.55	8.09	7.45	2.28
210-210	3"	9.17	8.95	9.05	3.03
210-211	4"	10.73	10.16	11.19	3.86