

PVC Valve



Solvent Connection, Schedule 40, 150 WOG



S-702

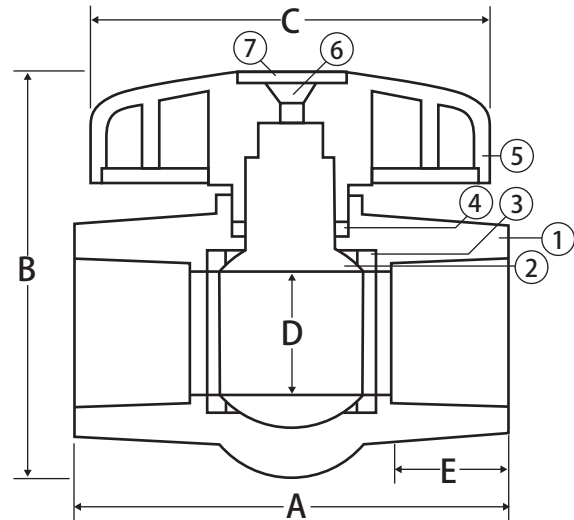

Features

- NPS Connections
- %100 Tested
- Minimal Pressure Drop/Turbulence
- Wetted Surfaces Contain Less than .25% Lead Content

Approvals

- NSF 61-8 Certified
- NSF 61 - Annex G
- NSF 372
- NSF/ANSI 14
- ASTM F1970

Pressure Rating

- Max service temperature 140°F, 150 PSI @ 73°F continuous
- Min temperature 41°F

Material Specifications

No.	Part	Materials
1	Body	UPVC
2	Ball / Stem	UPVC
3	Seat (2)	EPDM
4	O-ring	EPDM
5	Handle	ABS Plastic
6	Bolt	Steel - Zinc Plated
7	Cap	ABS Plastic

Dimensions

Part No.	Size	A	B	C	D	E
210-723	1/2"	3.10	2.52	2.76	0.55	0.87
210-724	3/4"	3.39	2.75	3.14	0.79	1.00
210-725	1"	3.92	3.23	3.62	0.98	1.12
210-726	1-1/4"	4.49	3.74	4.12	1.18	1.25
210-727	1-1/2"	5.12	4.34	4.39	1.42	1.38
210-728	2"	5.90	5.31	5.51	1.83	1.50



WARNING: This product can expose you to chemicals including lead which is known to the State of California to cause cancer, birth defects or other reproductive harm. For more information go to www.P65Warnings.ca.gov.