

RT-7288 Rental Sparge Cart



PRM Air Sparge Cart with Oil-Free Reciprocating Compressor for Pilot Testing and Remediation Applications.

Features Include:

- Mounted on Heavy Duty Industrial Hand Cart for Easy Maneuverability
- 1.6 KW 120V 1 Phase AS Compressors
- FLA: 32A Voltage: 120V
- Plug: (2) 120V 20A 3 Wire Straight Blade Plug (Same as a household outlet)
- Minimum Generator size: 10 KW
- 1-15 CFM Rotameter
- Brass Tubing Passive Heat Exchanger
- 10 scfm @ 30psig
- Flow Meter and Pressure Gauge
- HOA Control



Short or Long Term Lease Options or
Purchase Available!

(888-TREAT-IT) • www.prmfiltration.com • sales@prmfiltration.com

AIR SPARGE PILOT CART ELEVATION DETAIL

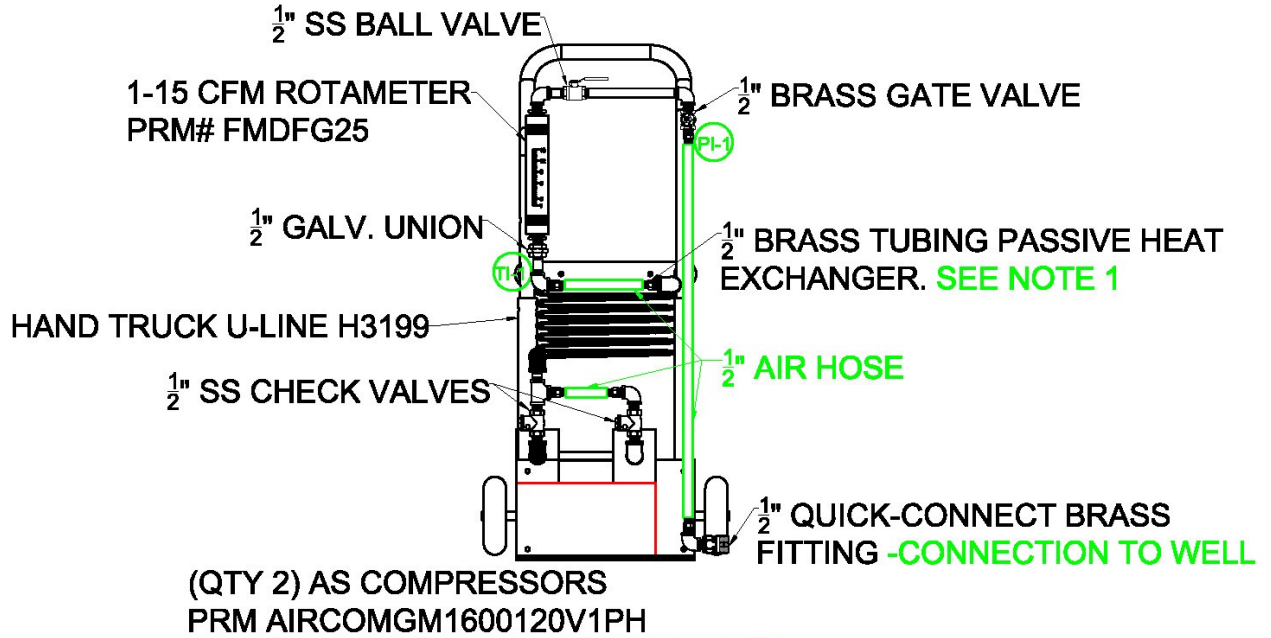

(QTY 2) AS COMPRESSORS
PRM AIRCOMGM1600120V1PH
1.6 KW 120V 1PH ODP SEE NOTES 2 & 3

GENERAL NOTES:

- BRASS TUBING WILL BE COILED TO MAXIMIZE LENGTH. 10'-30' TOTAL LENGTH. COIL CAN GO BEHIND PLUMBING. SHOWN AS-IS FOR DRAWING CLARITY
- THERE SHALL BE 2 COMPRESSORS. 2ND UNIT'S LOCATION TBD AND SHALL BE PLUMBED INTO BRASS TUBING PASSIVE HEAT EXCHANGER.
- THERE SHALL BE A SINGLE 120V, 30A PLUG W/ 25' OF CABLE WOUND ON A SIDE BRACKET. 120V FEED WILL SPLIT AND THERE WILL BE A SINGLE OVERLOAD/SWITCH FOR EACH COMPRESSOR. THE OVERLOAD/SWITCHES SHALL BE EASILY ACCESIBLE.
- COMPRESSORS SHALL HAVE GALV. RAIN GUARDS OVER MOTOR ENDS.

LOOSE EQUIPMENT:

- 10' OF 200 PSI AIR HOSE WILL BE PROVIDED W/ 1/2" MALE QUICK CONNECT FITTING ON ONE END AND 1/2" FEMALE QUICK CONNECT FITTING ON THE OTHER END

PRM PARTS LISTS

PRM PARTS	DESCRIPTION	PRM #
PI-1	0-100 PSI LF GAUGE	PGCNBTY6302515100PSI
PI-2	32-250 DEG F TEMP GAUGE	THERMOBTY760563

ELECTRICAL

1. VOLTAGE	120V
2. PHASE	1
3. AUTO RESTART	NO

Scale (ft.)

