

Environmental / Chemical Processing Blowers

EN 909 & CP 909

10.0 / 15.0 HP Sealed Regenerative w/Explosion-Proof Motor

ROTRON®

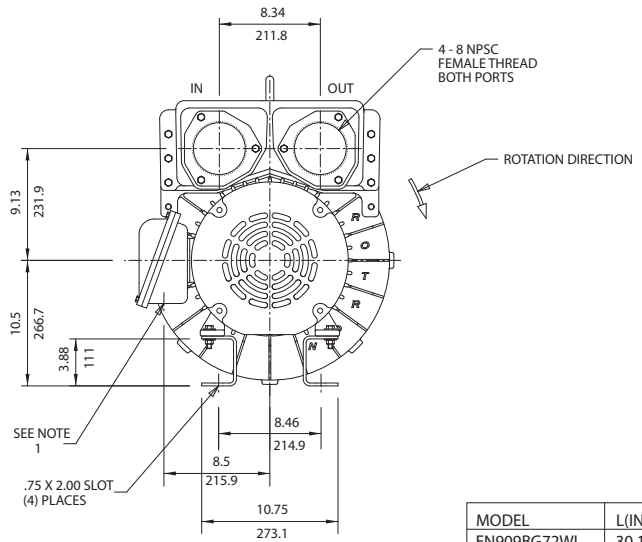
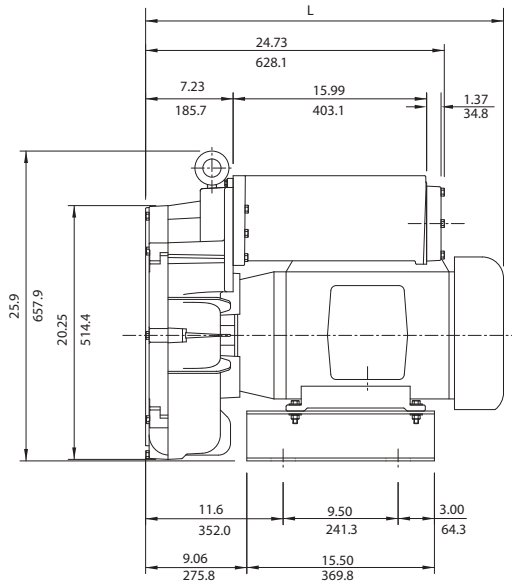

IN
MM

- NOTES
- 1 TERMINAL BOX CONNECTOR HOLE 1 1/4" NPT FEMALE THREAD.
 - 2 DRAWING NOT TO SCALE, CONTACT FACTORY FOR SCALE CAD DRAWING.
 - 3 CONTACT FACTORY FOR BLOWER MODEL LENGTHS NOT SHOWN.

MODEL	L(IN/MM)
EN909BG72WL	30.17/766.3
EN909DB72WL	23.66/601.0

Specification	Units	Part/Model Number			
		EN909BG72WL 081741	EN909BG86WL 081736	EN909BD72WL 081743	CP909GA72WLR 038982
Motor Enclosure - Shaft Mt.	-	Explosion-proof-CS	Explosion-proof-CS	Explosion-proof-CS	CHEM XP-SS
Horsepower	-	15	15	10	15
Phase - Frequency	-	Three-60 hz	Three-60 hz	Three-60 hz	Three-60 hz
Voltage	AC	230/460	575	230/460	230/460
Motor Nameplate Amps	Amps (A)	36/18	14.4	24/12	36/18
Max. Blower Amps	Amps (A)	48/24	18	32/16	48/24
Locked Rotor Amps	Amps (A)	240/120	100	234/117	240/120
Service Factor	-	2/2	2	2/1	2/2
Starter Size	-	1.0	1.0	1.0	1.0
Thermal Protection	-	Class B - Pilot Duty	Class B - Pilot Duty	Class B - Pilot Duty	Class B - Pilot Duty
XP Motor Class - Group	-	I-D, II-F&G	I-D, II-F&G	I-D, II-F&G	I-D, II-F&G
Shipping Weight	Lbs	524	524	504	524
	Kg	237.7	237.7	228.6	237.7

Voltage - ROTRON motors are designed to handle a broad range of world voltages and power supply variations. Our dual voltage 3 phase motors are factory tested and certified to operate on both: **208-230/415-460 VAC-3 ph-60 Hz** and **190-208/380-415 VAC-3 ph-50 Hz**. Our dual voltage 1 phase motors are factory tested and certified to operate on both: **104-115/208-230 VAC-1 ph-60 Hz** and **100-110/200-220 VAC-1 ph-50 Hz**. All voltages above can handle a ±10% voltage fluctuation. Special wound motors can be ordered for voltages outside our certified range.

Operating Temperatures - Maximum operating temperature: Motor winding temperature (winding rise plus ambient) should not exceed 140°C for Class F rated motors or 120°C for Class B rated motors. Blower outlet air temperature should not exceed 140°C (air temperature rise plus inlet temperature). Performance curve maximum pressure and suction points are based on a 40°C inlet and ambient temperature. Consult factory for inlet or ambient temperatures above 40°C.

Maximum Blower Amps - Corresponds to the performance point at which the motor or blower temperature rise with a 40°C inlet and/or ambient temperature reaches the maximum operating temperature.

XP Motor Class - Group - See Explosive Atmosphere Classification Chart in Section I

Shop.PRMFiltration.Com
855-341-7649

This document is for informational purposes only and should not be considered as a binding description of the products or their performance in all applications. The performance data on this page depicts typical performance under controlled laboratory conditions. AMETEK is not responsible for blowers driven beyond factory specified speed, temperature, pressure, flow or without proper alignment. Actual performance will vary depending on the operating environment and application. AMETEK products are not designed for and should not be used in medical life support applications. AMETEK reserves the right to revise its products without notification. The above characteristics represent standard products. For product designed to meet specific applications, contact AMETEK Technical & Industrial Products Sales department.

AMETEK DYNAMIC FLUID SOLUTIONS
75 North Street, Saugerties, NY 12477
USA: +1 215-256-6601 - Europe: +49 7703 930909 - Asia: +86 21 5763 1258
Customer Service Fax: +1 215.256.1338
www.ametekdfs.com

D 33

AMETEK®
PRECISION MOTION CONTROL
DYNAMIC FLUID SOLUTIONS