

5.0 HP Sealed Regenerative w/Explosion-Proof Motor

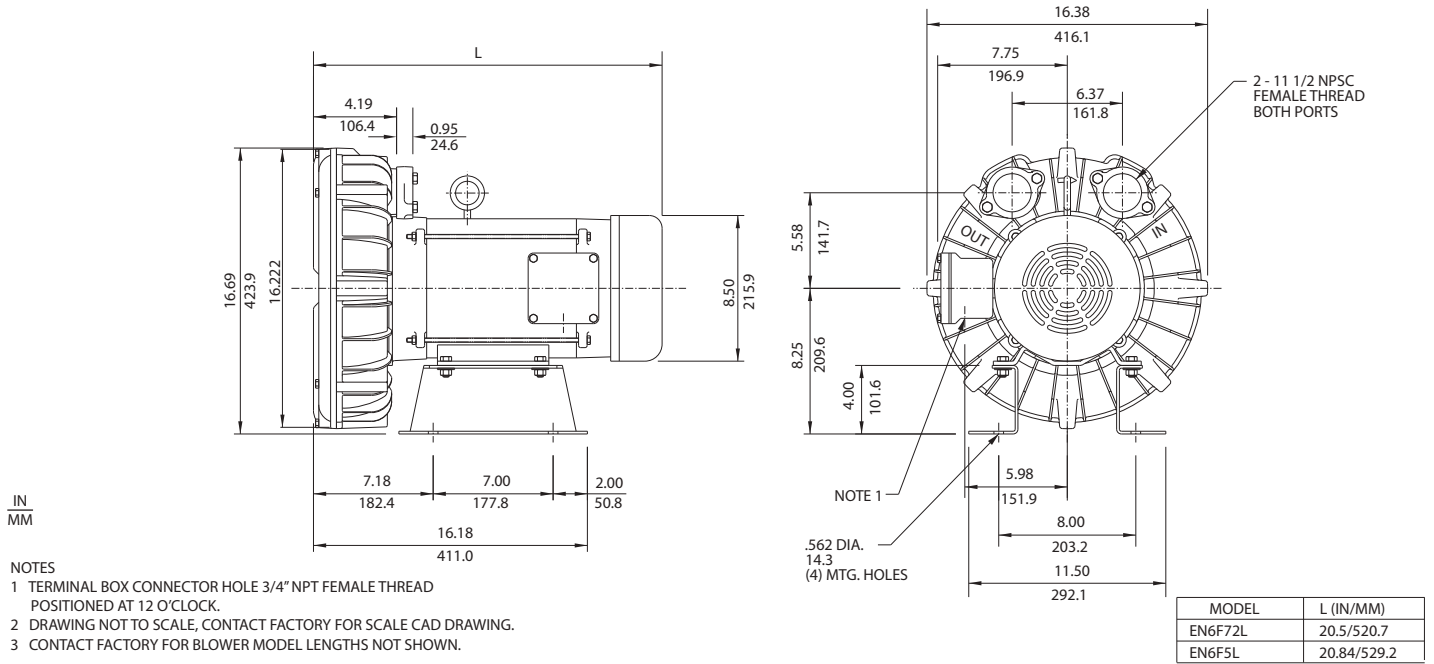

IN  
MM

- NOTES  
 1 TERMINAL BOX CONNECTOR HOLE 3/4" NPT FEMALE THREAD POSITIONED AT 12 O'CLOCK.  
 2 DRAWING NOT TO SCALE, CONTACT FACTORY FOR SCALE CAD DRAWING.  
 3 CONTACT FACTORY FOR BLOWER MODEL LENGTHS NOT SHOWN.

MODEL	L (IN/MM)
EN6F72L	20.5/520.7
EN6F5L	20.84/529.2

Specification	Units	Part/Model Number				
		EN6F5L 038361	EN6F72L 038180	EN6F86L 038438	CP6FW5LR TBD	CP6FW72LR 038978
Motor Enclosure - Shaft Mt.	-	Explosion-proof-CS	Explosion-proof-CS	Explosion-proof-CS	CHEM XP-SS	CHEM XP-SS
Horsepower	-	5.0	5.0	5.0	5.0	5.0
Phase - Frequency Voltage	-	Single-60 hz	Three-60 hz	Three-60 hz	Single-60 hz	Three-60 hz
Motor Nameplate Amps	AC	230	230/460	575	230	230/460
Max. Blower Amps	Amps (A)	19.5	14/7	5.7	19.5	14/7
Locked Rotor Amps	Amps (A)	23	14/7	6.3	23	14/7
Service Factor	Amps (A)	175	152/76	38	175	152/76
Starter Size	-	2	1/0	0	2	1/0
Thermal Protection	-	1.0	1.0	1.0	1.0	1.0
XP Motor Class - Group	-	Class B - Pilot Duty	Class B - Pilot Duty	Class B - Pilot Duty	Class B - Pilot Duty	Class B - Pilot Duty
	-	I-D, II-F&G	I-D, II-F&G	I-D, II-F&G	I-D, II-F&G	I-D, II-F&G
Shipping Weight	Lbs	190	167	167	190	167
	Kg	86.2	75.7	75.7	86.2	75.7

**Voltage** - ROTRON motors are designed to handle a broad range of world voltages and power supply variations. Our dual voltage 3 phase motors are factory tested and certified to operate on both: **208-230/415-460 VAC-3 ph-60 Hz** and **190-208/380-415 VAC-3 ph-50 Hz**. Our dual voltage 1 phase motors are factory tested and certified to operate on both: **104-115/208-230 VAC-1 ph-60 Hz** and **100-110/200-220 VAC-1 ph-50 Hz**. All voltages above can handle a ±10% voltage fluctuation. Special wound motors can be ordered for voltages outside our certified range.

**Operating Temperatures** - Maximum operating temperature: Motor winding temperature (winding rise plus ambient) should not exceed 140°C for Class F rated motors or 120°C for Class B rated motors. Blower outlet air temperature should not exceed 140°C (air temperature rise plus inlet temperature). Performance curve maximum pressure and suction points are based on a 40°C inlet and ambient temperature. Consult factory for inlet or ambient temperatures above 40°C.

**Maximum Blower Amps** - Corresponds to the performance point at which the motor or blower temperature rise with a 40°C inlet and/or ambient temperature reaches the maximum operating temperature.

**XP Motor Class - Group** - See Explosive Atmosphere Classification Chart in Section I

**Shop.PRMFiltration.Com**  
**855-341-7649**

This document is for informational purposes only and should not be considered as a binding description of the products or their performance in all applications. The performance data on this page depicts typical performance under controlled laboratory conditions. AMETEK is not responsible for blowers driven beyond factory specified speed, temperature, pressure, flow or without proper alignment. Actual performance will vary depending on the operating environment and application. AMETEK products are not designed for and should not be used in medical life support applications. AMETEK reserves the right to revise its products without notification. The above characteristics represent standard products. For product designed to meet specific applications, contact AMETEK Technical & Industrial Products Sales department.