

Industrial / Chemical Processing Blowers

# ROTRON®

## DR 505 & CP 505

2.0 / 3.0 HP Regenerative Blower

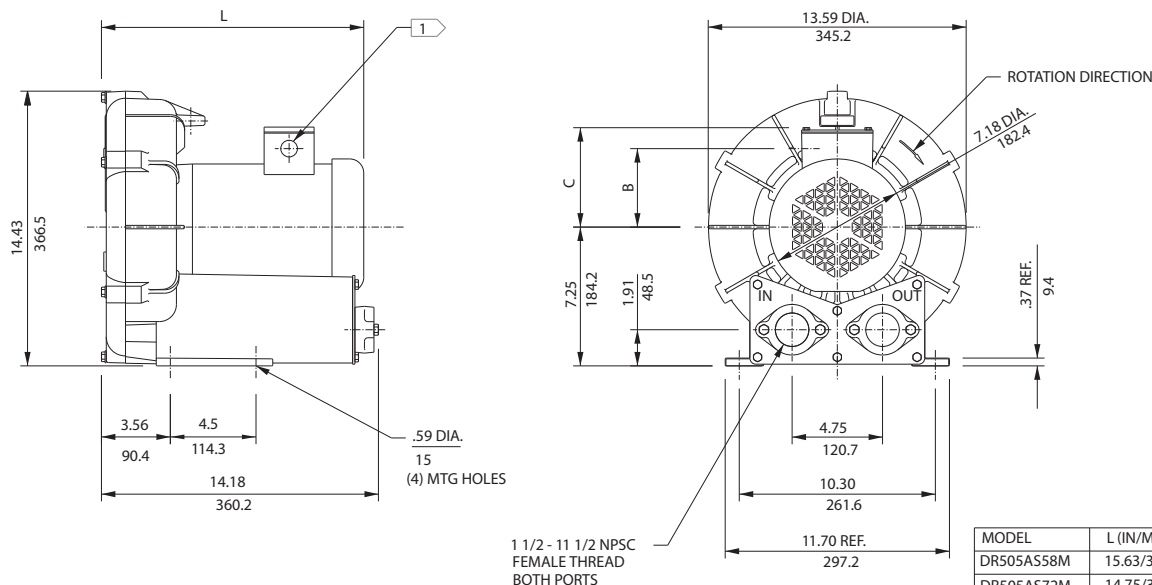

IN  
MM

- NOTES  
 1) TERMINAL BOX CONNECTOR HOLE .88 (22) DIA.  
 2) DRAWING NOT TO SCALE, CONTACT FACTORY FOR SCALE CAD DRAWING.  
 3) CONTACT FACTORY FOR BLOWER MODEL LENGTHS NOT SHOWN.

MODEL	L (IN/MM)	B (IN/MM)	C (IN/MM)
DR505AS58M	15.63/397	4.63/117	5.64/143
DR505AS72M	14.75/374	4.25/108	5.25/133
DR505AS86M	14.38/365	4.37/111	5.18/131
DR505K58M	17.0/431	4.63/117	5.64/143
DR505K72M	15.63/397	4.37/111	5.18/131

Specification	Units	Part/ Model Number							
		DR505AS58M 037542	DR505AS72M 037543	DR505AS86M 037544	DR505K58M 081882	DR505K72M 037551	CP505FE72MLR 038239	CP505CT72MLR 038237	
Motor Enclosure - Shaft Mt.	-	TEFC - CS	TEFC - CS	TEFC - CS	TEFC - CS	TEFC - CS	CHEM TEFC - SS	CHEM TEFC - SS	
Horsepower	-	2.0	2.0	2.0	3.0	3.0	3.0	2.0	
Voltage	AC	115/230	230/460	575	115/230	230/460	230/460	230/460	
Phase - Frequency	-	Single - 60 Hz	Three - 60 Hz	Three - 60 Hz	Single - 60 Hz	Three - 60 Hz	Three - 60 Hz	Three - 60 Hz	
Insulation Class	-	F	F	F	F	F	F	F	
NEMA Rated Motor Amps	Amps (A)	18.2/9.1	5.4/2.7	2.3	25.6/12.8	7.6/3.8	7.6/3.8	5.4/2.7	
Service Factor	-	1.15	1.15	1.15	1.15	1.15	1.15	1.15	
Max. Blower Amps	Amps (A)	24/11.5	7/3.5	3.0	28/14	8.8/4.4	8.8/4.4	6.8/3.4	
Locked Rotor Amps	Amps (A)	138/69	38/19	21	194/97	88/44	88/44	38/19	
NEMA Starter Size	-	1/0	00/00	00	1.5/0	0/0	0/0	00/00	
Shipping Weight	Lbs	97	82	84	91	86	86	82	
	Kg	44	37.2	38.1	41.3	39	39	37.2	

**Voltage** - ROTRON motors are designed to handle a broad range of world voltages and power supply variations. Our dual voltage 3 phase motors are factory tested and certified to operate on both: **208-230/415-460 VAC-3 ph-60 Hz** and **190-208/380-415 VAC-3 ph-50 Hz**. Our dual voltage 1 phase motors are factory tested and certified to operate on both: **104-115/208-230 VAC-1 ph-60 Hz** and **100-110/200-220 VAC-1 ph-50 Hz**. All voltages above can handle a ±10% voltage fluctuation. Special wound motors can be ordered for voltages outside our certified range.

**Operating Temperatures** - Maximum operating temperature: Motor winding temperature (winding rise plus ambient) should not exceed 140°C for Class F rated motors or 120°C for Class B rated motors. Blower outlet air temperature should not exceed 140°C (air temperature rise plus inlet temperature). Performance curve maximum pressure and suction points are based on a 40°C inlet and ambient temperature. Consult factory for inlet or ambient temperatures above 40°C.

**Maximum Blower Amps** - Corresponds to the performance point at which the motor or blower temperature rise with a 40°C inlet and/or ambient temperature reaches the maximum operating temperature.

**Shop.PRMFiltration.Com**  
**855-341-7649**

*This document is for informational purposes only and should not be considered as a binding description of the products or their performance in all applications. The performance data on this page depicts typical performance under controlled laboratory conditions. AMETEK is not responsible for blowers driven beyond factory specified speed, temperature, pressure, flow or without proper alignment. Actual performance will vary depending on the operating environment and application. AMETEK products are not designed for and should not be used in medical life support applications. AMETEK reserves the right to revise its products without notification. The above characteristics represent standard products. For product designed to meet specific applications, contact AMETEK Technical & Industrial Products Sales department.*