

### PVC HEADER DUAL BFH SKID PLAN DETAIL

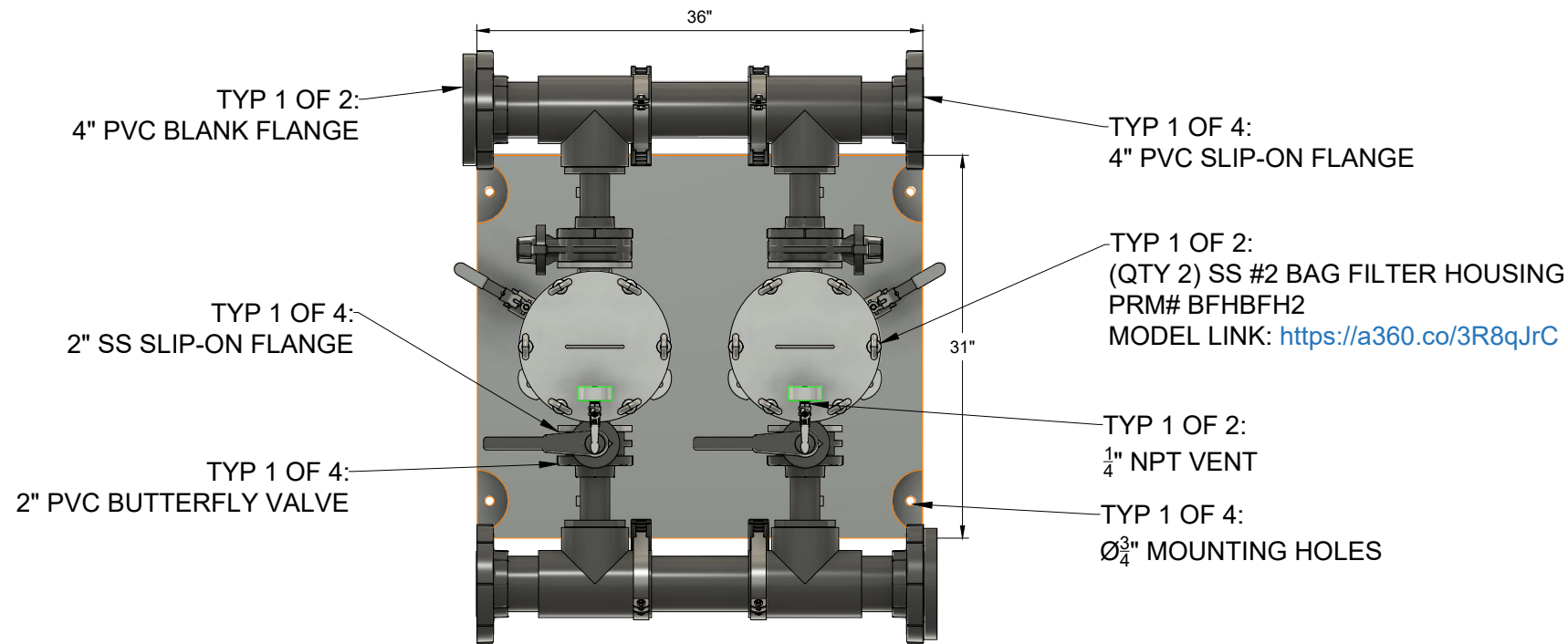

### PVC HEADER DUAL BFH SKID ISOMETRIC DETAIL

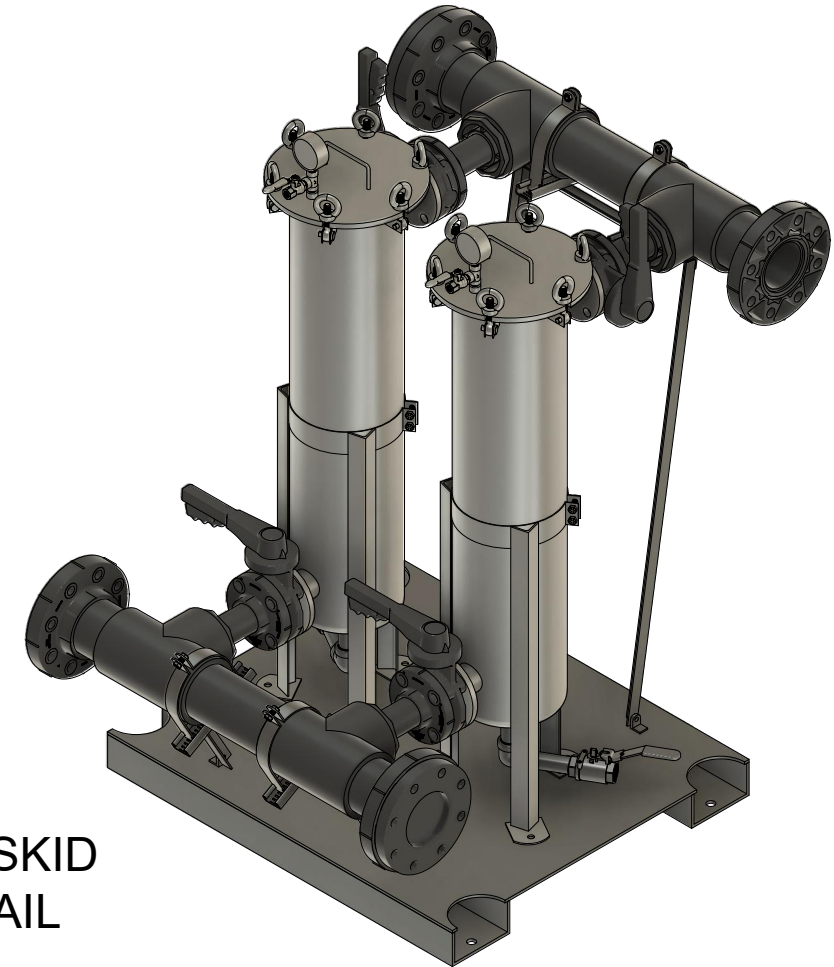

### PVC HEADER DUAL BFH SKID FRONT ELEVATION DETAIL

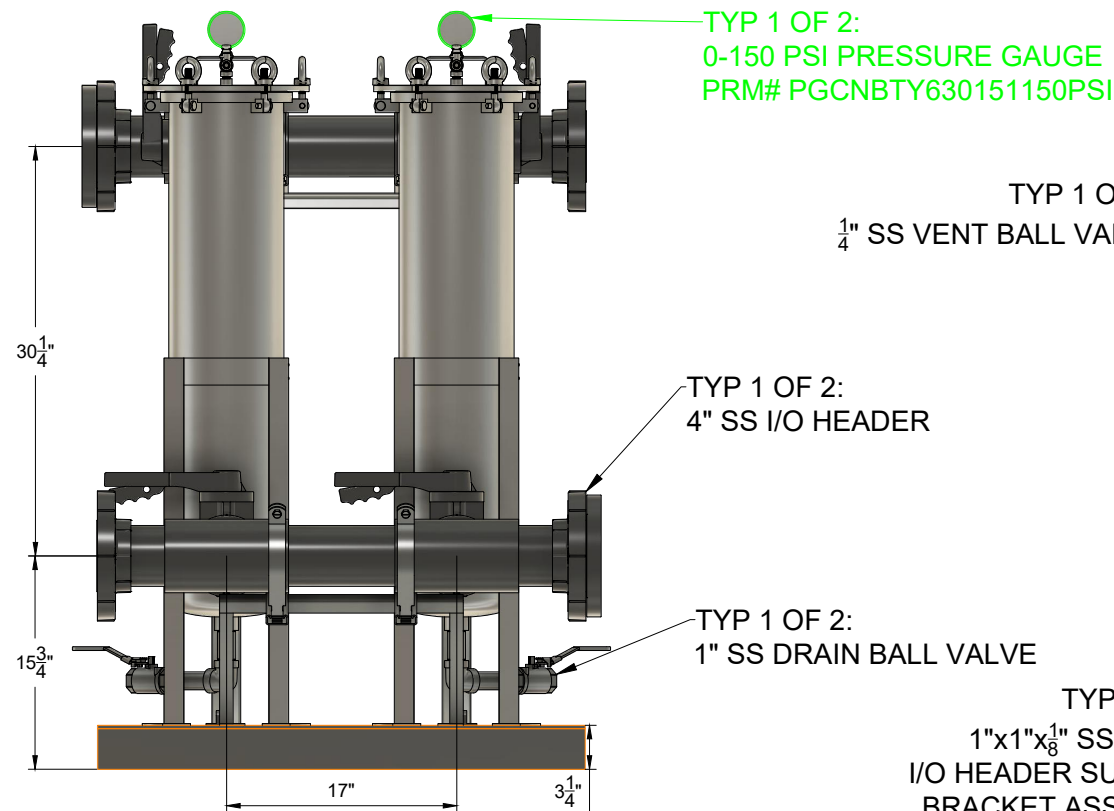

### PVC HEADER DUAL BFH SKID RIGHT ELEVATION DETAIL

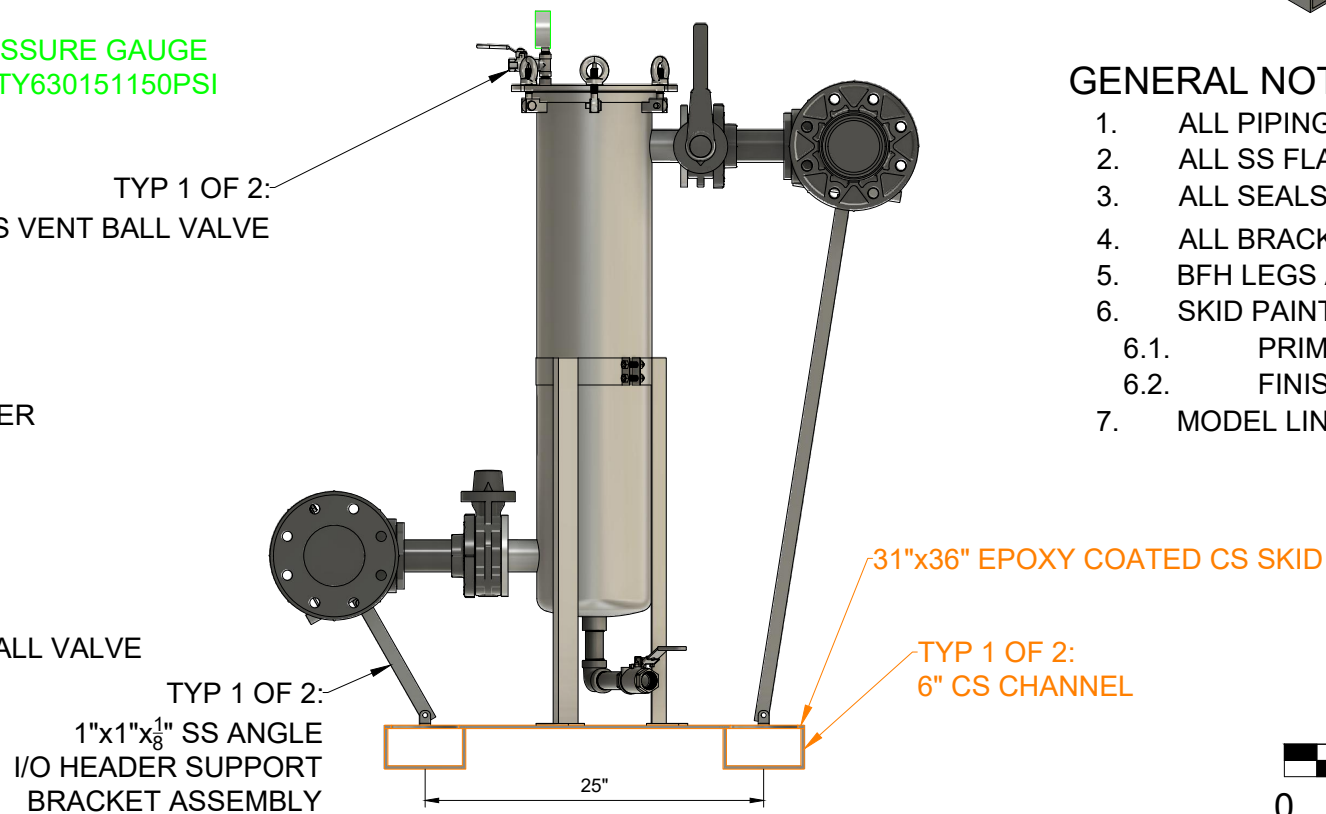

#### GENERAL NOTES:

1. ALL PIPING IS SCH-80 PVC
2. ALL SS FLANGES ARE SLIP-ON
3. ALL SEALS AND GASKETS ARE VITON
4. ALL BRACKETS BOLTED IN PLACE WITH 3/8" BOLTS
5. BFH LEGS ARE BOLTED TO SKID PLATE
6. SKID PAINT DETAILS:
  - 6.1. PRIMER: EPOXY PRIMER (HBE-400)
  - 6.2. FINISH: GRAY URETHANE FINISH (AUE-100)
7. MODEL LINK: <https://a360.co/3VprWO3>

Scale (ft.)

