

NO.	ITEM	QTY	MATERIAL	NOTES
1	LEG	3	316 SS	ADJUSTABLE HEIGHT
2	DRAIN	1	316 SS	1" TRI CLAMP
3	EXHAUST VENT	1	316 SS	1" TRI CLAMP
4	OUTLET	1	316 SS	1" TRI CLAMP
5	SHELL	1	316 SS	
6	SHELL CLAMP	1	316 SS	
7	LID	1	316 SS	
8	SWING BOLTS	3	304 SS	M12
9	O-RING	1	VITON	
10	BRACKETS	3	316 SS	
11	INLET	1	316 SS	1" TRI CLAMP

NOTES:

1. PRM FILTRATION IS ONLY A SUPPLIER OF THIS EQUIPMENT.
2. PRM IS NOT RESPONSIBLE FOR SPECIFYING THIS PRODUCT FOR THE APPLICATION.
3. BUYERS AND/OR USER SHOULD REQUIRE AN ENGINEER FOR ENSURING THAT THE PROPER EQUIPMENT IS INSTALLED FOR THE APPLICATION INCLUDING ALL PROPER SAFETY PRACTICES.
4. PRM IS NOT RESPONSIBLE FOR ANY DAMAGES TO PROPERTY AND/OR INJURY/DEATH RELATED TO IMPROPER INSTALLATION. FILTRATION EQUIPMENT INSTALLATIONS SHOULD ALWAYS INCLUDE ANCILLARY SAFETY DEVICES AND/OR OPERATIONAL PRACTICES.
5. IT IS AGREED THAT PRM NOR ITS OWNERS HAVE LIABILITY WITH THE INSTALLATION AND OPERATION OF THESE OR OTHER PRODUCTS PURCHASED FROM PRM.
6. ALLOW UP TO $\frac{1}{4}$ " TOLERANCE ON ALL MEASUREMENTS.
7. MODEL LINK: <https://a360.co/3ootP2F>

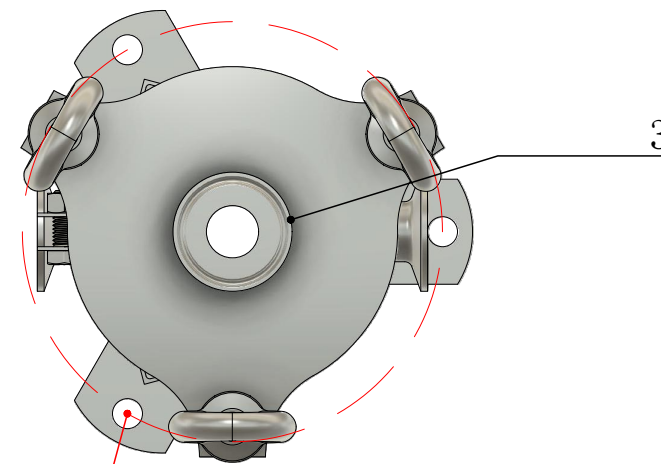

FOOT ANCHOR
HOLES Ø7"

