



36" Hybrid Composite Railing Installation Guide

v20200618



NewTechWood

CONTENTS

| | |
|---|----------------|
| Important notes | 1 - 3 |
| Straight Railing and Post Parts | 4 |
| Straight Railing Installation | 5 - 6 |
| i: Installing the Post Mount on a Concrete Surface | 7 - 8 |
| ii: Installing the Post Mount on a Deck | 9 - 11 |
| Straight Railing Installation Continued | 12 - 15 |
| Stair Railing and Post Parts | 16 |
| Stair Railing Installation | 17 - 18 |
| i: Installing the Post Mount on a Concrete Surface | 19 - 20 |
| ii: Installing the Post Mount on a Deck | 21 - 23 |
| Stair Railing Installation Continued | 24 - 28 |

**For the most up to date information, please visit our website:
www.newtechwood.com**

Please consult local zoning laws in regards to the load requirements and bottom space requirements for rails. All supporting structures must be in accordance with applicable building codes. Neighborhood associations and/or historic districts may regular size, type, placement and ability of railing. Apply for permits if required by local authorities and codes. Ensure compliance prior to installation. Local building code requirements will always supersede any and all suggested procedures and measurements in the following installation. The following installation instructions are intended as a general guideline based on common building practices used in railing installations.

IMPORTANT:

Read All Sections Before You Start

For the most up to date information, please visit our website @ www.newtechwood.com

Prior to installing any composite product, it is recommended that you check with local building codes for any special requirements or restrictions. The diagrams and instructions outlined in this guide are for illustration purposes only and are not meant or implied to replace a licensed professional. Any construction or use of NewTechWood must be in accordance with all local zoning and/or building codes. The consumer assumes all risks and liability associated with the construction and use of this product.

Safety

When dealing with any type of construction project, it is necessary to wear appropriate safety equipment to avoid any injuries. NewTechWood recommends but is not limited to the following safety equipment when handling, cutting, and installing NewTechWood: gloves, a respiratory protection, long sleeves, pants, and safety glasses.

Tools

Standard woodworking tools may be used. It is recommended that all blades have a carbide tip. Standard stainless steel or acceptable coated deck screws and nails are recommended.

Environment

A clean, smooth flat, and strong surface is needed to install NewTechWood's products correctly. Please always check with local building codes before installing any type of railing. If installation does not occur immediately NewTechWood's products need to be put on a flat surface at all times. It should never be put on an uneven surface.

Planning

Plan a layout for your railing before starting it to ensure the best possible looking railing for your project. Building codes and zoning ordinances generally apply to permanent structures, meaning anything that is anchored to the ground or attached to the house. So nearly every kind of railing requires permits and inspections from a local building department. We recommend drawing out a site plan of your proposed project that you intend to do to minimize errors and make your perfect railing.

Construction

NewTechWood UltraShield is NOT intended for use as columns, support posts, beams, joist stringers, support against a force, or other primary load bearing members. NewTechWood must be supported by a code-compliant substructure.

Static

Static can also be more prevalent in areas that are of higher altitude because the humidity is lower. For these areas, be careful of using conducive objects such as metal railing and chairs as static shocks might occur more often. A potential way to lower the amount of static shocks occurring is to apply Staticide (www.aclstaticide.com) on your deck or use anti-static mats before doorways.

Storage

NewTechWood's products always need to be stored on flat solid surfaces. Surfaces such as dirt and grass are not sufficient as they can move over time.

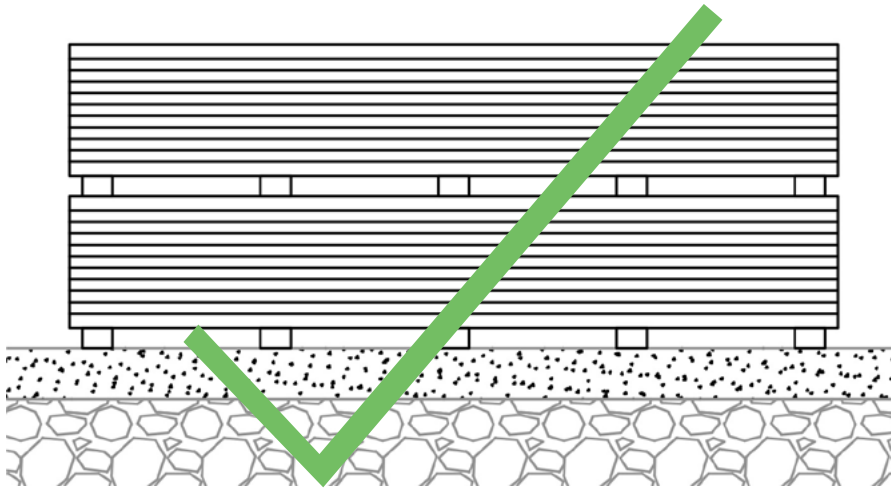

NewTechWood products shown above put on a flat surface on joists, this is the correct way for storage.

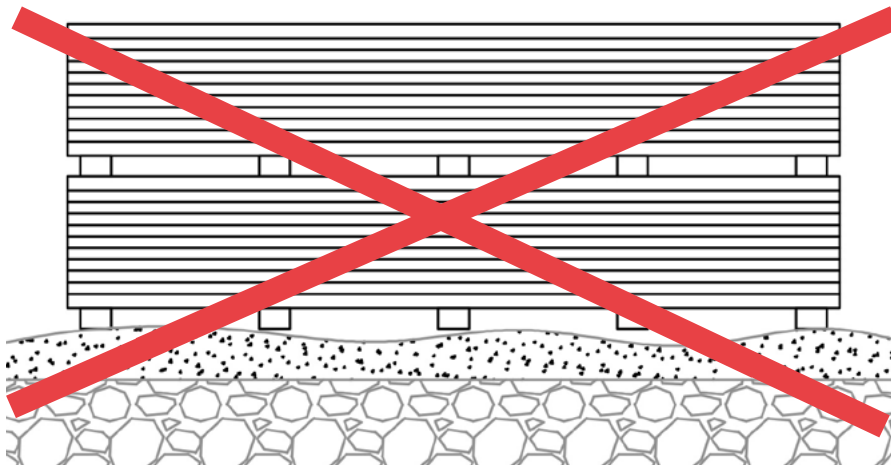









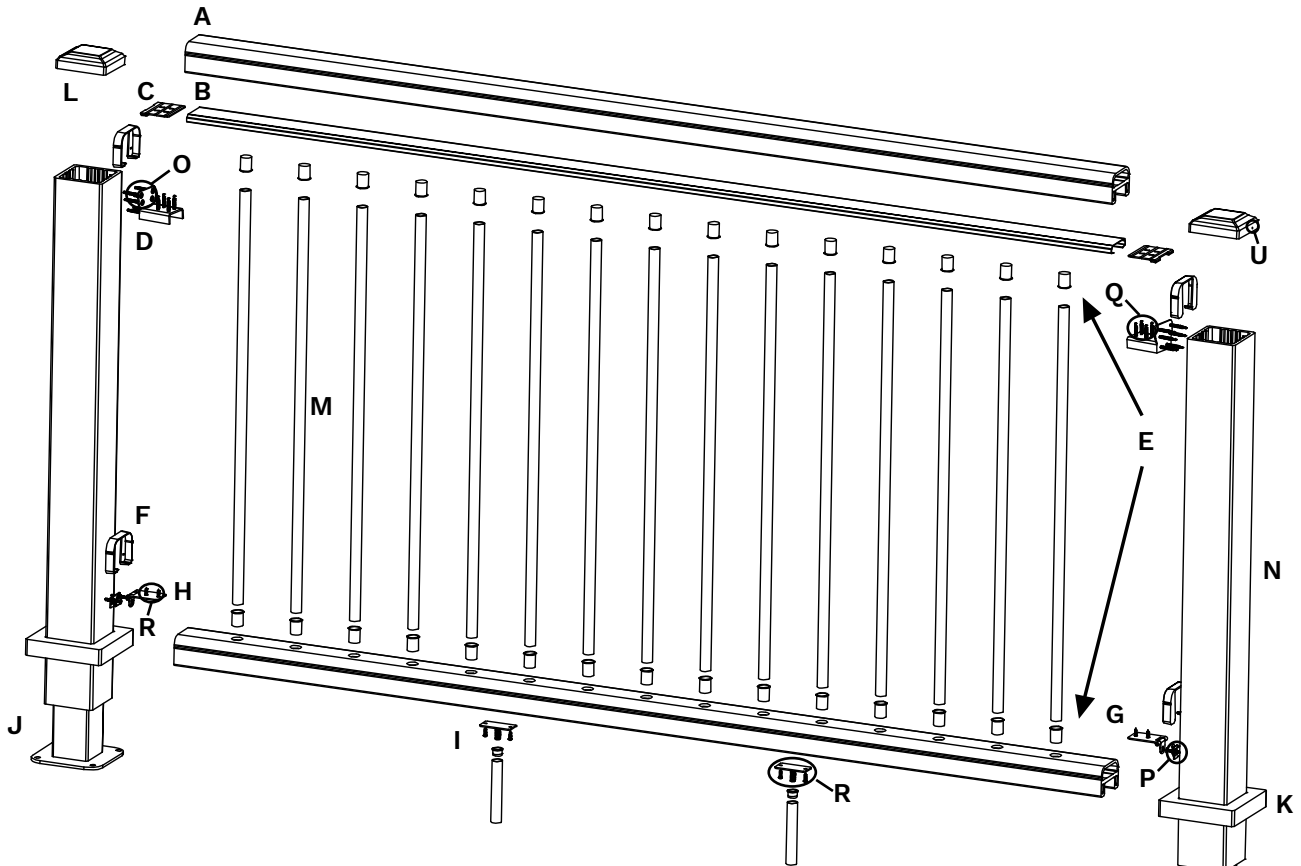



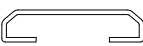

NewTechWood products shown above on an uneven surface which will make the products prone to warping and distortion.

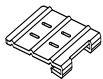
Straight Railing And Post Parts:

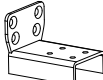
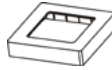
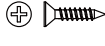
IMPORTANT POINTS:

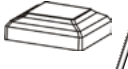
- Parts D, E, and F will be different from those displayed in the stair railing and post parts.
- All other parts are the same for straight and stair railings and posts.

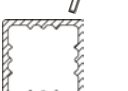

| | | | | | | |
|------------------------|---|-----------------------|---|---|---|--|
| A - UR02 (X2) |  | H - R0204 (X2) |  | O - WJ0130 # 10 x 1 37/64" (M5 x 40 mm) |  | |
| B - R0224-1 (X1) |  | I - R0222 (X2) |  | P - WJ0131 # 8 x 1 37/64" (M4 x 40 mm) |  | S - WJ0094 # 5/16 x 3 5/32" (M8 x 80 mm) |
| C - R0224-2 (X2) |  | J - R0221-36 (X2) |  | Q - WJ0143 # 8 x 1 3/16" (M4 x 30 mm) |  | T - WJ0161 # 5/16 x 5" (M8 x 130 mm) |
| D - R0223 (X2) |  | K - LV-0119 (X2) |  | R - WJ0149 # 8 x 25/32" (M4 x 20 mm) |  | U - WJ0153 # 5 x 15/32" (M3 x 12 mm) |
| E - LV-0218-B (X30) |  | L - LV-0120 (X2) |  | | | |
| F - R0102 (X4) |  | M - R0218-36 (X15) |  | | | |
| G - R0205 (X2) |  | N - UH35 (X2) |  | | | |

Straight Railing Installation:

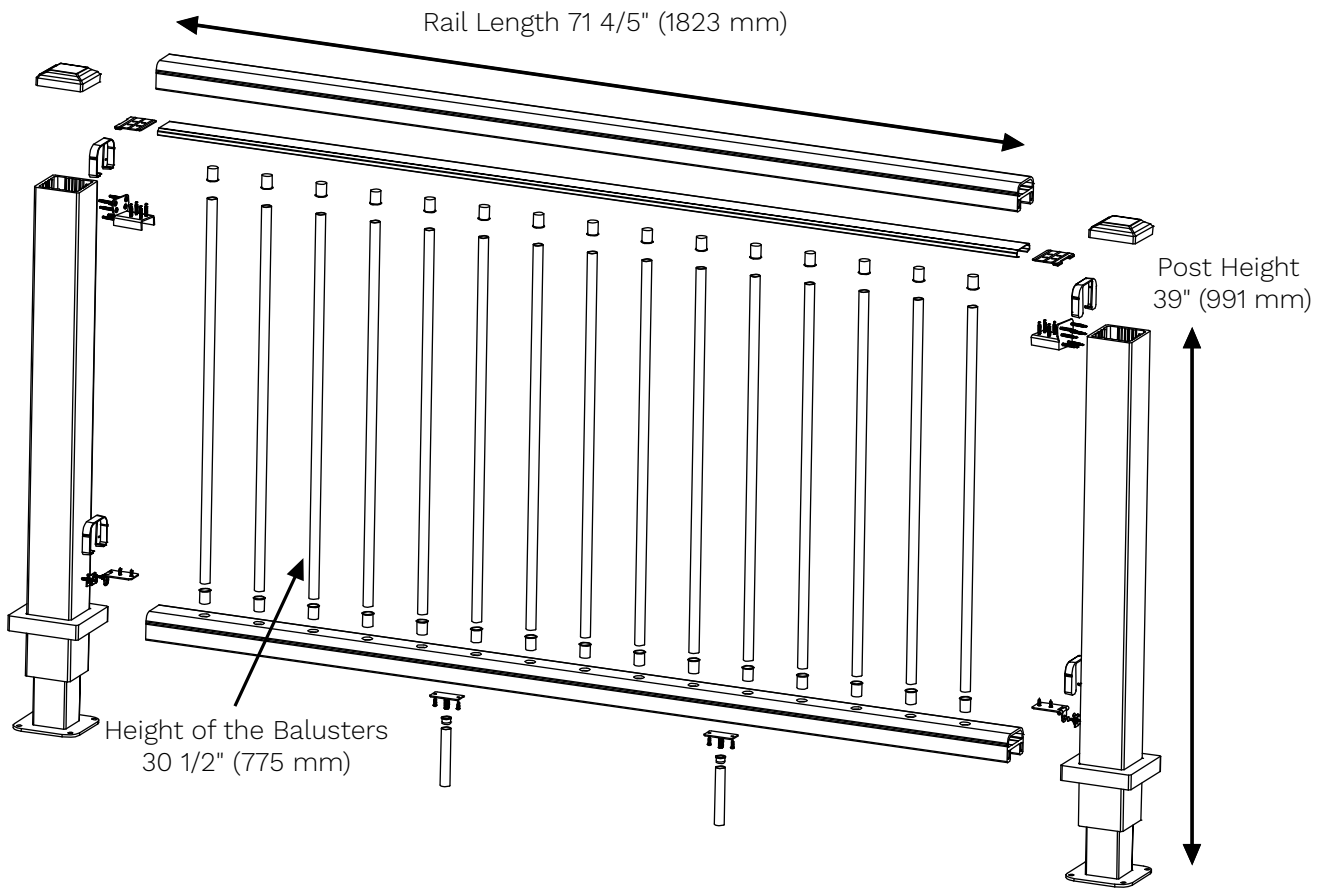

IMPORTANT POINTS:

- This railing is designed for a maximum of 71 4/5" (1823 mm) internal rail length.
- Aluminum balusters (M-R0218-36) DO NOT need to be cut for the straight railing 30 1/2" (775 mm).
- Cut the handrail, the bottom rail and the galvanized insert on each side to comply with the Canadian Building Code, which requires a maximum width of 4" (102 mm) between the balusters.
- Posts need to be cut to the proper design height of 39" (991 mm) for the composite sleeve and 36 4/5" (937 mm) for the steel post.
- Foot blocks should be evenly spaced out depending on the length of the final rail.
- Foot blocks cannot be installed underneath a pre-drilled baluster hole.

- 1 Mark where the post mount (J-R0221-36) will be installed. The maximum distance of the post mount is $75 \frac{3}{5}$ " (1923 mm) from center to center as shown in diagram 1.

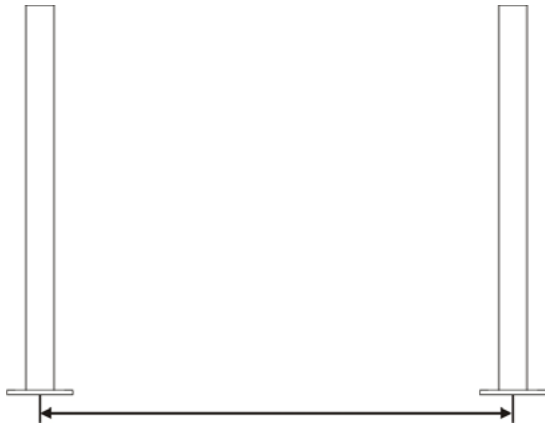

DIAGRAM 1

- 2 Cut post mount (J-R0221-36) to the length of $36 \frac{4}{5}$ " (937 mm) as shown in diagram 2.

Cut post sleeve (N-UH35) to the length of 39" (991 mm) as shown in diagram 3.

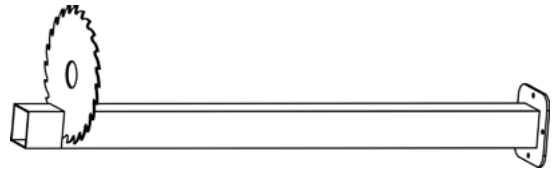

DIAGRAM 2

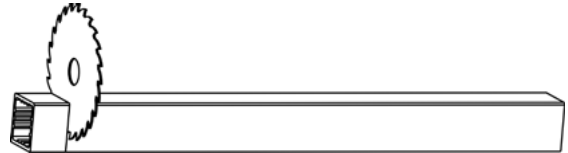

DIAGRAM 3

- 3 Install the post mount (J-R0221-36) as shown in diagram 4-20.

Note: Screw WJ0094 is used when installed on concrete. Screw WJ0161 is used when installed on deck.

Installing the Post Mount on a Concrete Surface

a. First position the post with the metal base in the position of installation. Then use a marker or pencil to mark the drilling hole positions as shown in Diagram 4.

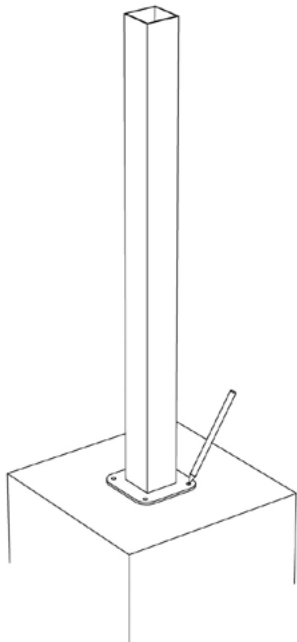

DIAGRAM 4

b. Now take a drill and drill in the spots marked previously as shown in Diagram 5.

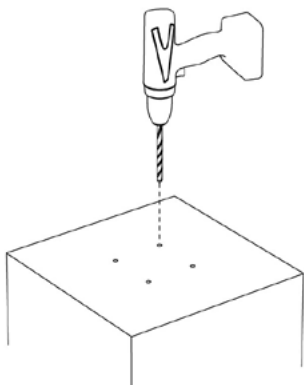

DIAGRAM 5

c. Insert the plastic anchors into the drilled holes as shown in Diagram 6.



Φ12 X 75

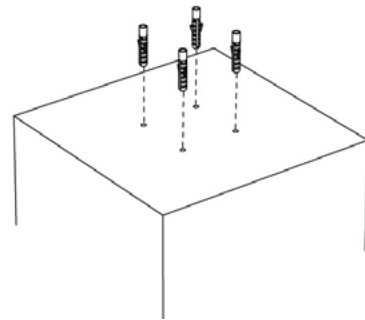

DIAGRAM 6

d. Position the post with the metal base over the predrilled holes and then insert the screws (S-WJ0094) into the designated holes as shown in Diagram 7.



S-WJ0094

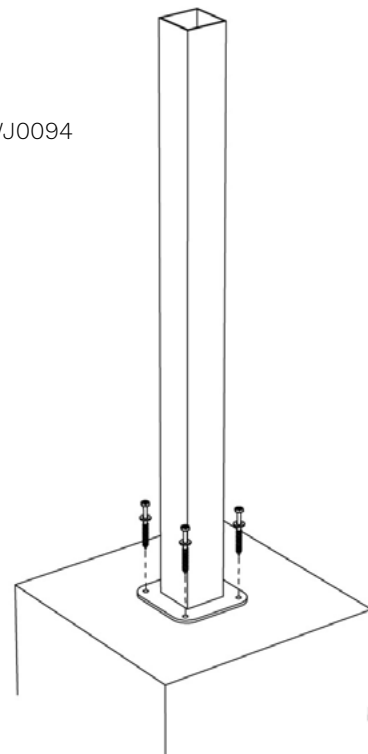

DIAGRAM 7

e. Now fix and tighten each screw, once complete it should look like Diagram 8.

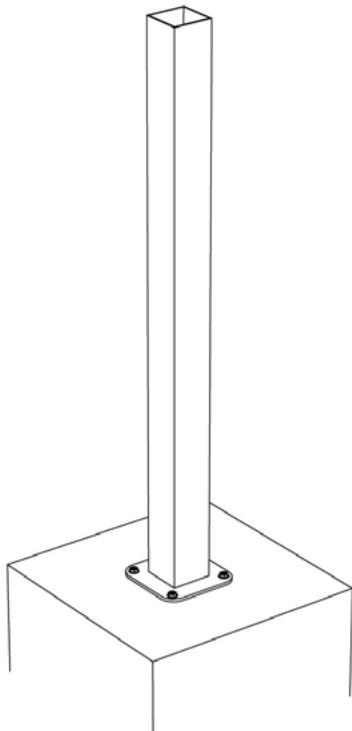

DIAGRAM 8

g. Put the post skirt over the post sleeve as shown in Diagram 10.

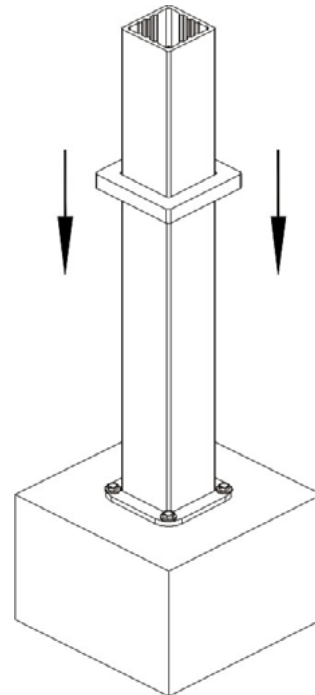

DIAGRAM 10

f. Install the post sleeve (N-UH35) as shown in Diagram 9.

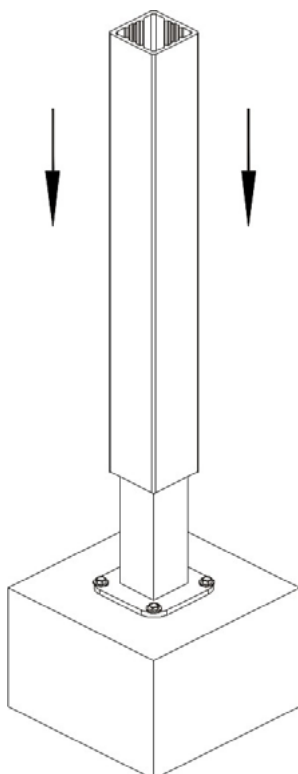

DIAGRAM 9

h. Then put the post cap on top of the post sleeve as shown in Diagram 11.

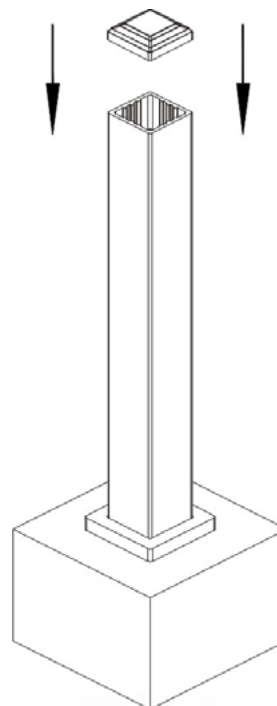

DIAGRAM 11

Installing the Post Mount on a Deck

a. Following Diagram 12, 13 position the post with the metal base.

Note: Installing directly on the board requires a substrate underneath in order for the screws to fully secure the board, ensure careful attention is paid to Diagram 12, 13.

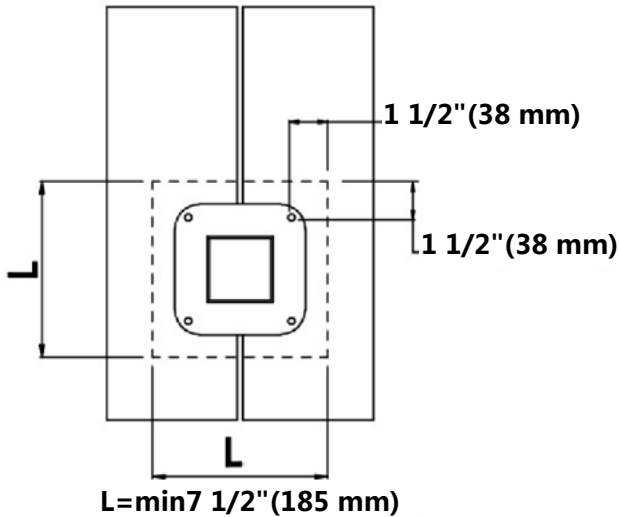
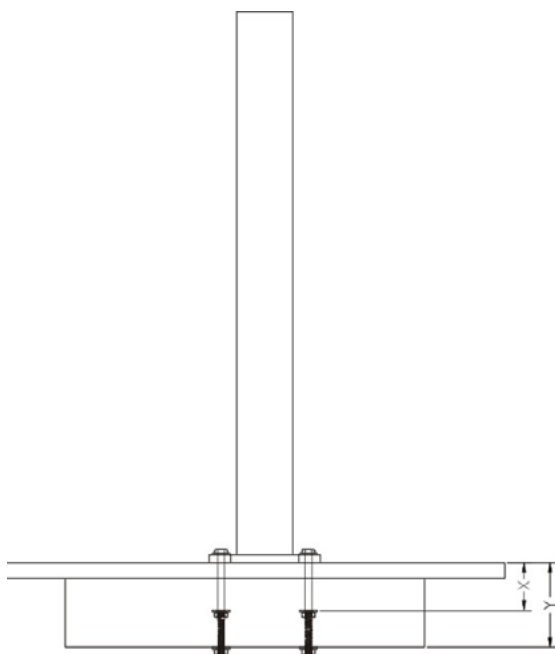

DIAGRAM 12



$X \geq 2 \frac{11}{20}''$ (65 mm)

$Y \leq 4 \frac{1}{2}''$ (115 mm)

DIAGRAM 13

Note: The substrate underneath has to fit in between the range shown in Diagram 13.

b. Once the post is in the correct position mark the holes with a marker or pencil as shown in Diagram 14.

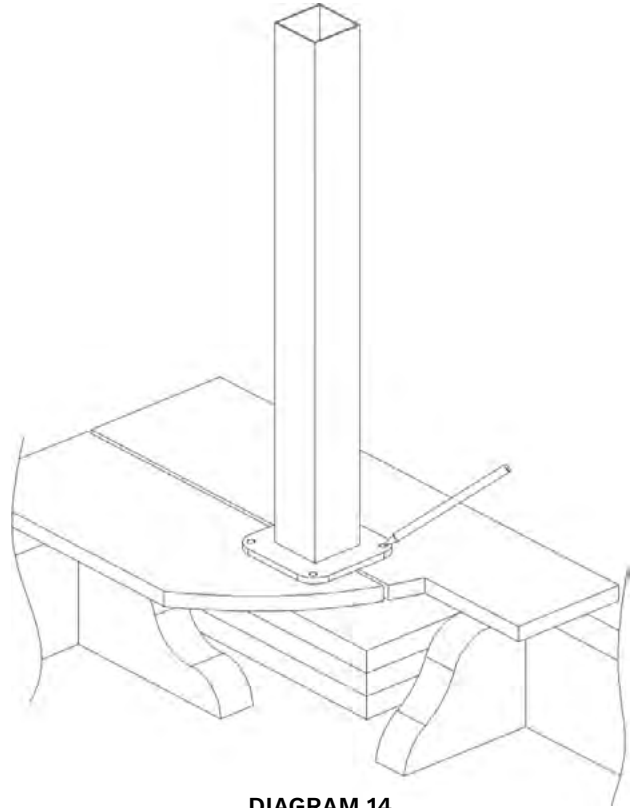

DIAGRAM 14

c. Now take a drill and drill the holes previously marked as shown in Diagram 15.

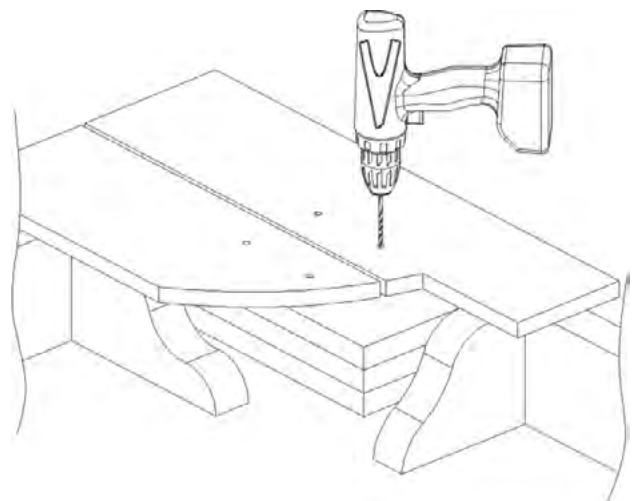

DIAGRAM 15

d. Put the post back over the predrilled holes and insert the screws (T-WJ0161) lag bolts into place as shown in Diagram 16.

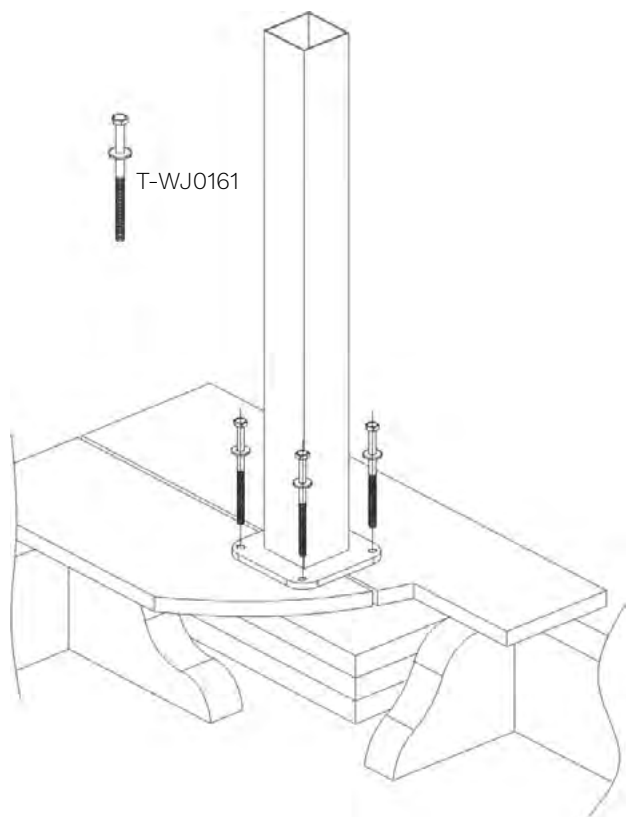

DIAGRAM 16

e. Tighten the lag bolts with washers underneath the substrate as shown in Diagram 17.

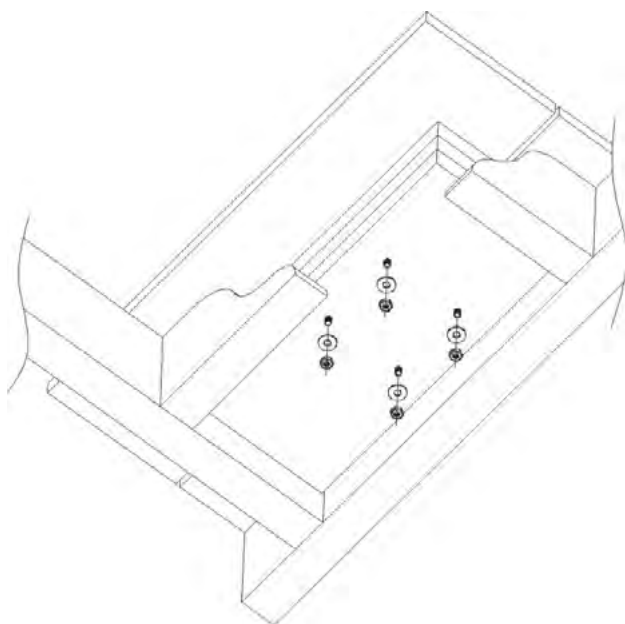

DIAGRAM 17

f. The composite post can now be put over the metal insert as shown in Diagram 18.

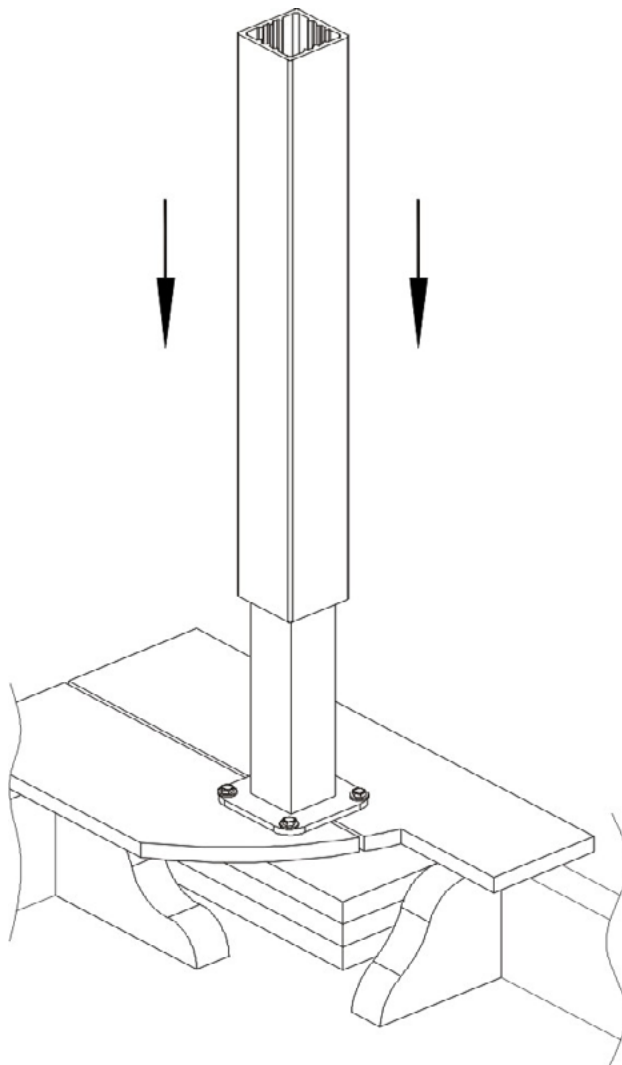

DIAGRAM 18

g. Finally take the post skirt and put it over the composite post to cover the bottom of the metal insert as shown in Diagram 19. Then take the post cap and cover the top of the composite post as shown in Diagram 20.

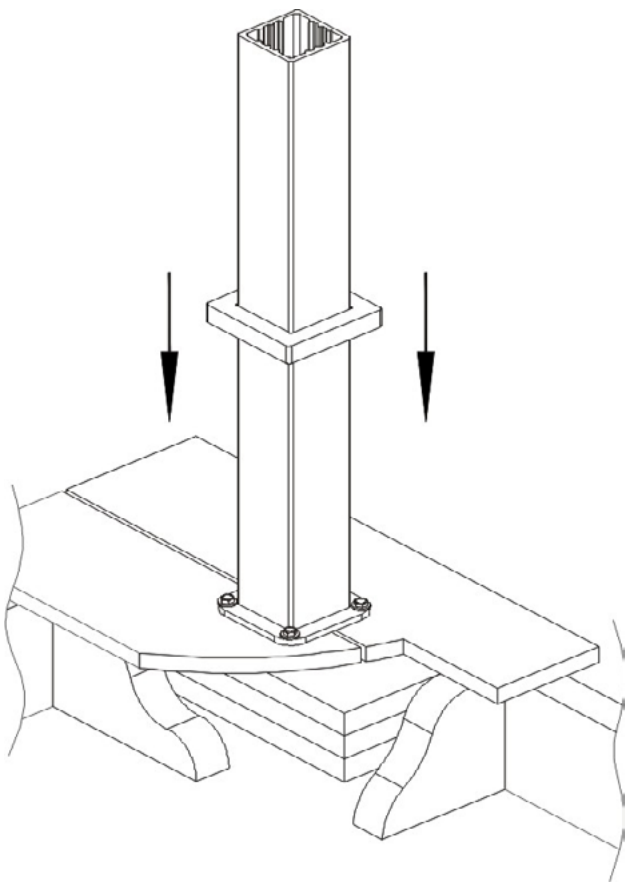

DIAGRAM 19

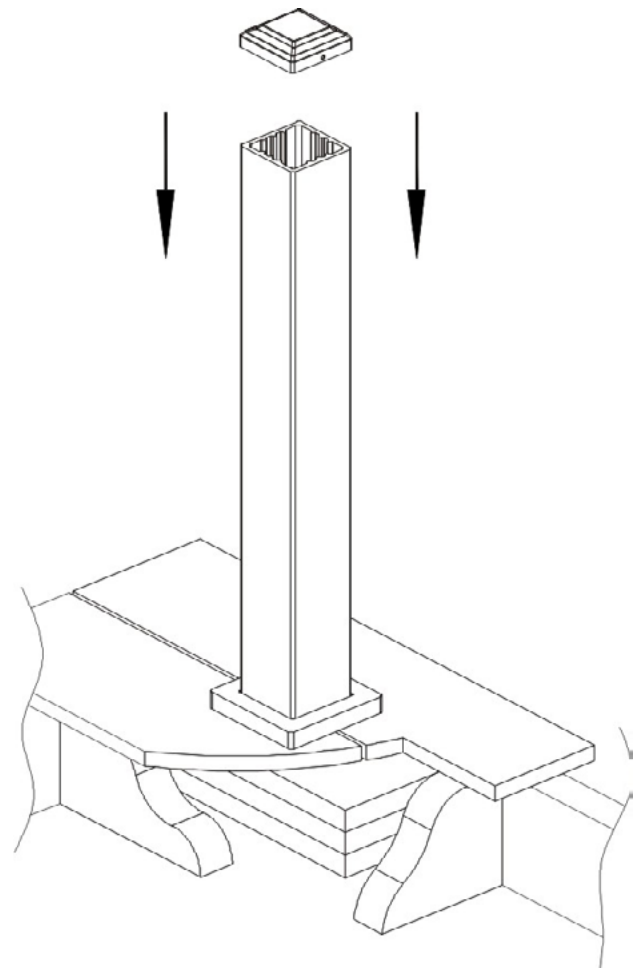

DIAGRAM 20

Straight Railing Installation Continued

- 4** Mark where the post brackets will be installed with the "Straight Railing" cardboard template as shown in diagram 21. Use the top 6 holes for top post brackets and use the bottom 2 holes for the bottom post brackets as shown in diagram 22.

Note: The cardboard template location should be measured from the bottom.

Pre-drill post bracket holes with a 7/64 inch (3 mm) bit.

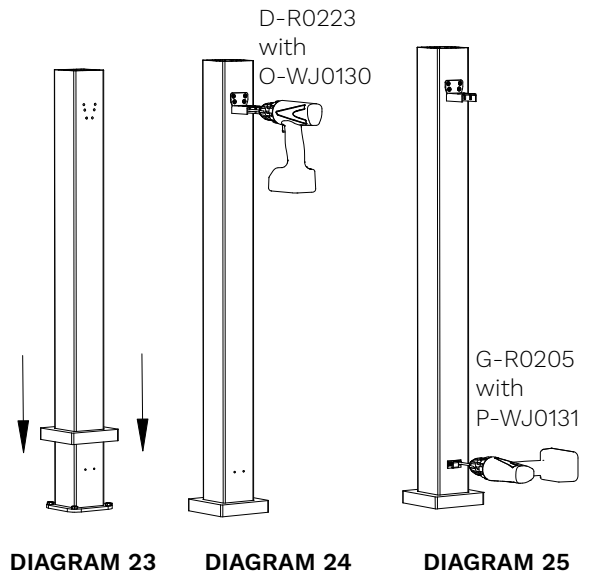
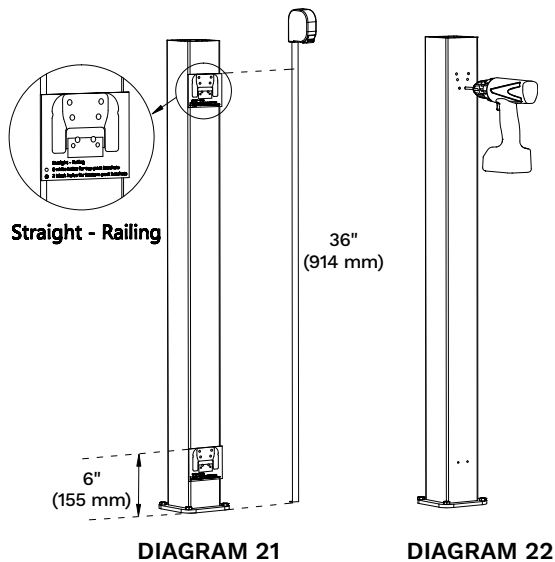

- 6** Cut rail (A-UR02) to the length between the post sleeve (N-UH35) minus 7/64" (3 mm) on each side for inserting the gaskets (F-R0102) as shown in diagram 26.

Remember to take out galvanized insert (B-R0224-1) before cutting rail (A-UR02). The galvanized insert (B-R0224-1) should be cut 6/25" (6 mm) shorter than the rail (A-UR02).

Note: Need to leave at least 3" (75 mm) between the ends of the rail and the first hole of each end as shown in diagram 27.



DIAGRAM 26

- 5** Lower the post skirt (K-LV-0119) over the post sleeve (N-UH35) as shown in diagram 23.

Drill in the top post brackets (D-R0223) with screw (O-WJ0130) as shown in diagram 24.

Drill in the bottom post brackets (G-R0205) with screw (P-WJ0131) as shown in diagram 25.

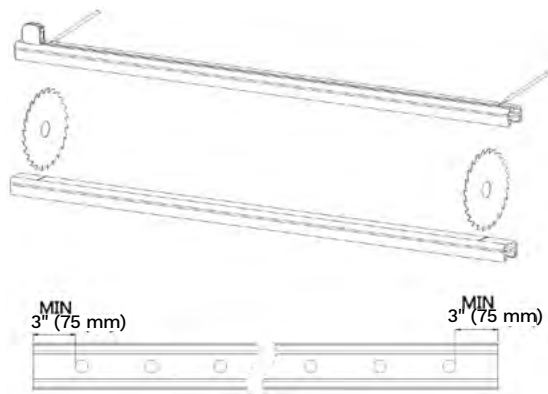

DIAGRAM 27

- 7** The bottom bracket (H-R0204) should be installed with screw (R-WJ0149) at 1 1/2" (29.5 mm) and 1" (24 mm) from the ends of the rail as shown in diagram 28. Alternatively, a flat board can be used to press the bracket up against the end of rail to line up the correct distance.

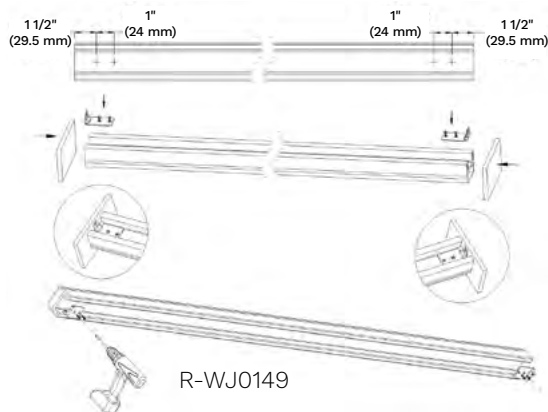

DIAGRAM 28

- 8** Pre-drill and install the foot blocks (I-R0222) with screw (R-WJ0149) on the bottom rail as shown in diagram 29. Foot blocks should be evenly spaced out depending on the length of the final rail and cannot be installed underneath a pre-drilled baluster hole.

Note: Top rail is A in diagram 30. The holes should be facing downwards. Bottom rail is B in diagram 30. The holes should be facing upwards.

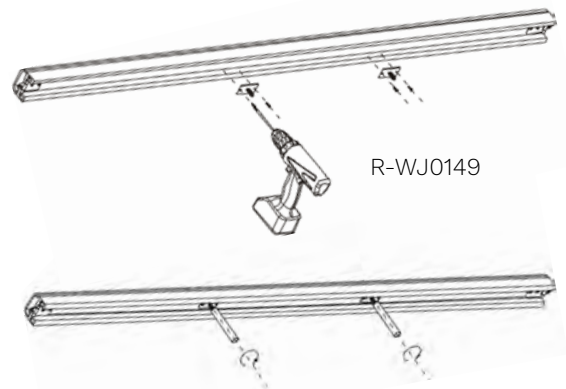

DIAGRAM 29

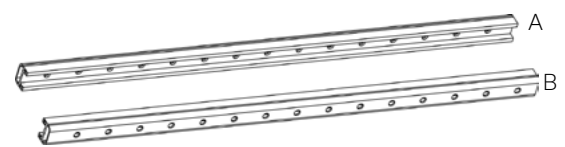

DIAGRAM 30

- 9** Attach the bottom rail (A-UR02) onto the bottom post brackets (G-R0205) as shown in diagram 31.

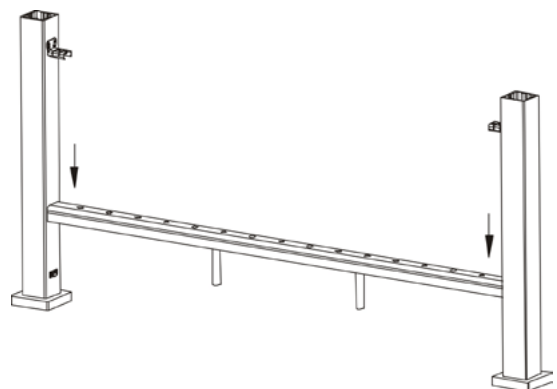

DIAGRAM 31

- 10** Install the baluster plugs (E-LV-0218-B) and aluminum balusters (M-R0218-36) as shown in diagram 32.

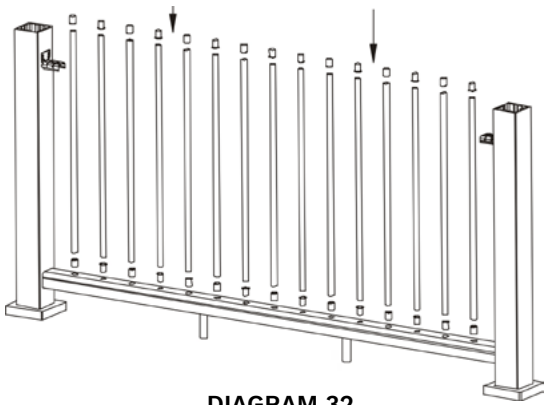

DIAGRAM 32

- 11 Attach the galvanized adaptors (C-R0224-2) on both ends of the galvanized insert (B-R0224-1) as shown in diagram 33.

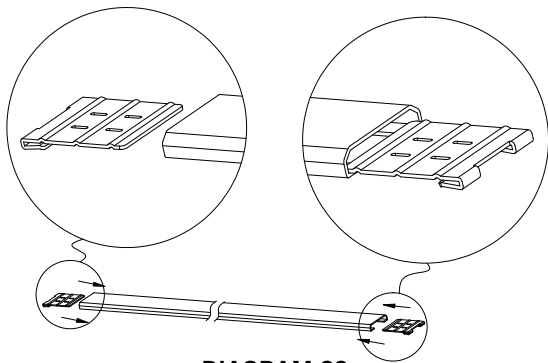

DIAGRAM 33

- 12 Slide the galvanized insert (B-R0224-1) into the top rail (A-UR02) as shown in diagram 34.



DIAGRAM 34

- 13 Attach the top rail (A-UR02) onto the top of the post brackets (D-R0223) as shown in diagram 35.

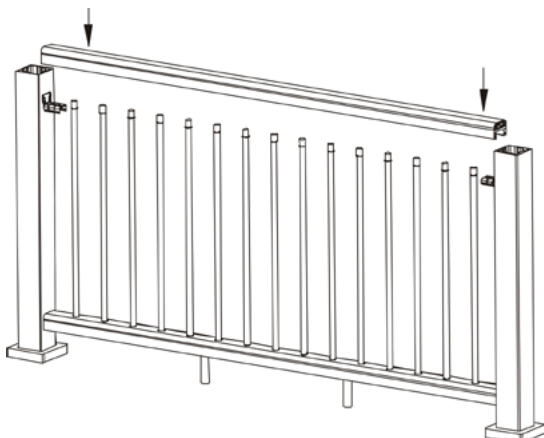

DIAGRAM 35

- 14 Pre-drill and install with screw (Q-WJ0143) as shown in diagram 36.

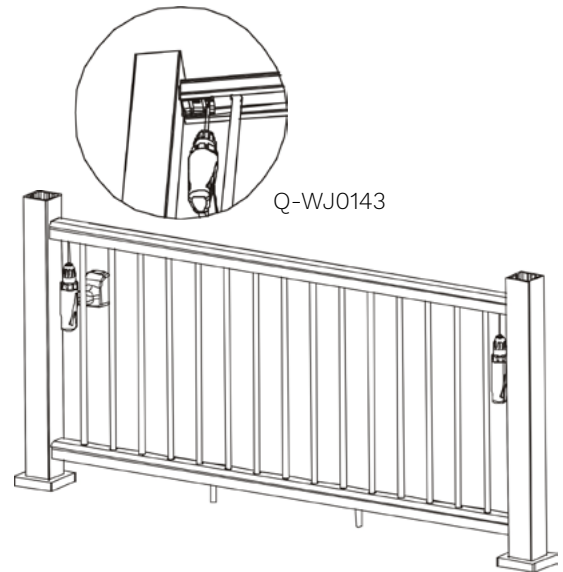

DIAGRAM 36

- 17 Attach post caps (L-LV-0120) and gaskets (F-R0102) as shown in diagram 37.

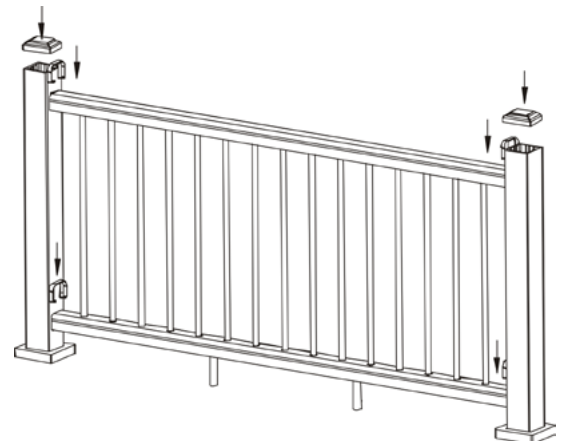

DIAGRAM 37

- 18 If needed adjust the foot blocks (I-R0222) to the correct height as shown in diagram 38.

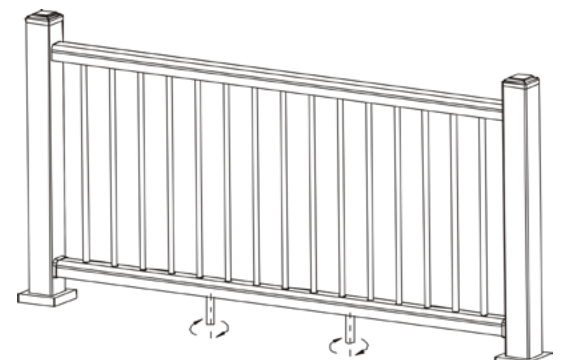

DIAGRAM 38

- 19 Install the post cap (L-LV-0120) with screw (U-WJ0153) as shown in diagram 39.

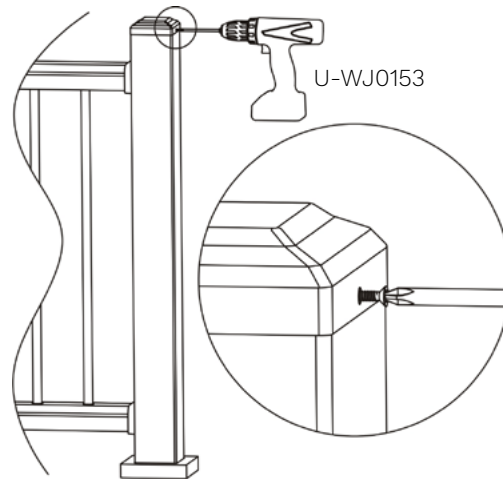
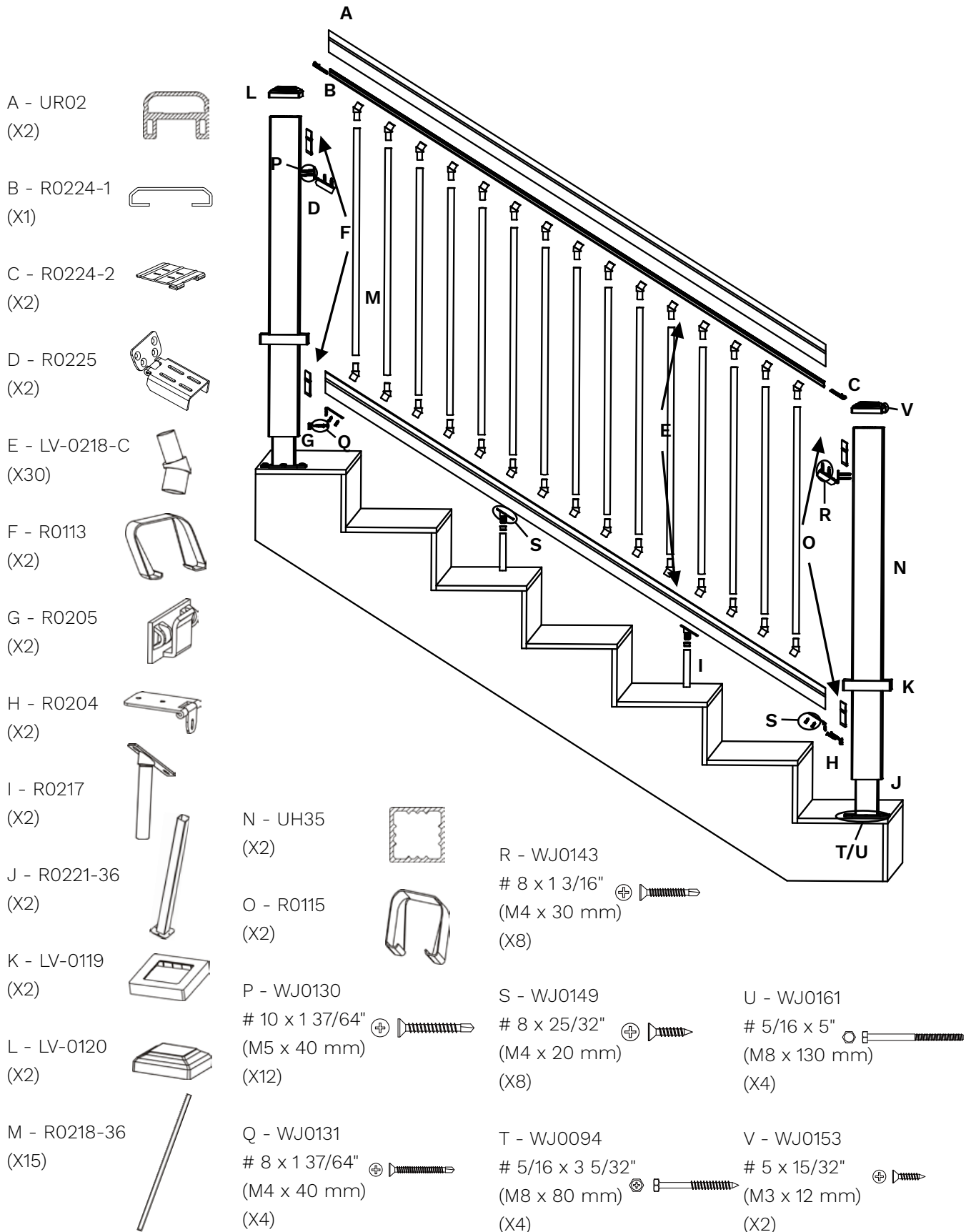

DIAGRAM 39

Stair Railing And Post Parts:

- Parts D, E, F, and O will be different from those displayed in the stair railing and post parts.
- All other parts are the same for straight and stair railings and posts.



Stair Railing Installation:

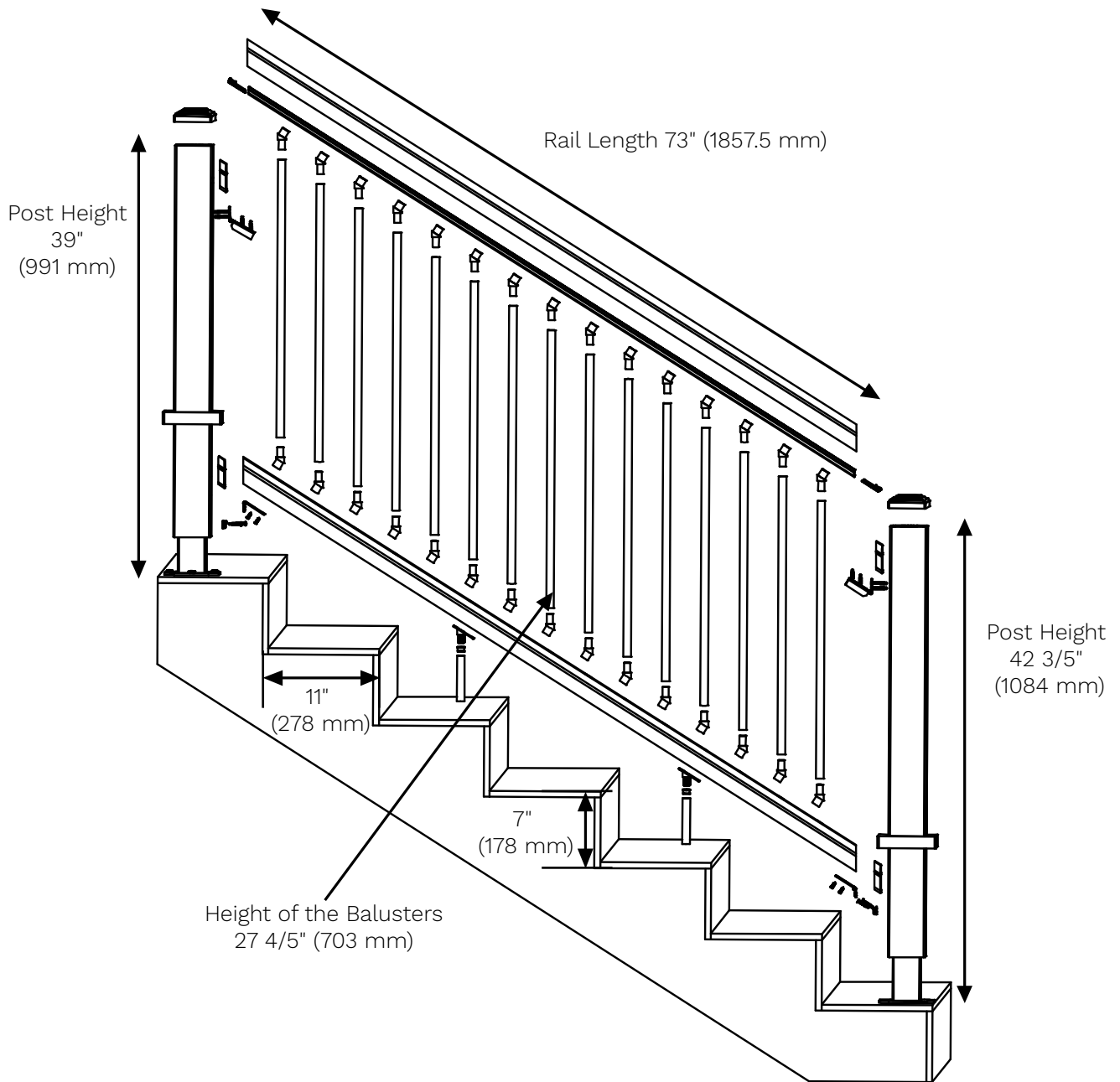

IMPORTANT POINTS:

- The stair railing is designed for a 32 degree angle with stair treads at 11" (278 mm) and stair risers 7" (178 mm).
- The stair railing is designed for a 73" (1857.5 mm) rail length.
- Aluminum balusters for the stair rail need to be cut to the height of 27 4/5" (703 mm).

- 1 Mark where the post mount (J-R0221-36) will be installed. The maximum distance of the post mount is $64 \frac{4}{5}$ " (1645 mm) as shown in diagram 1.

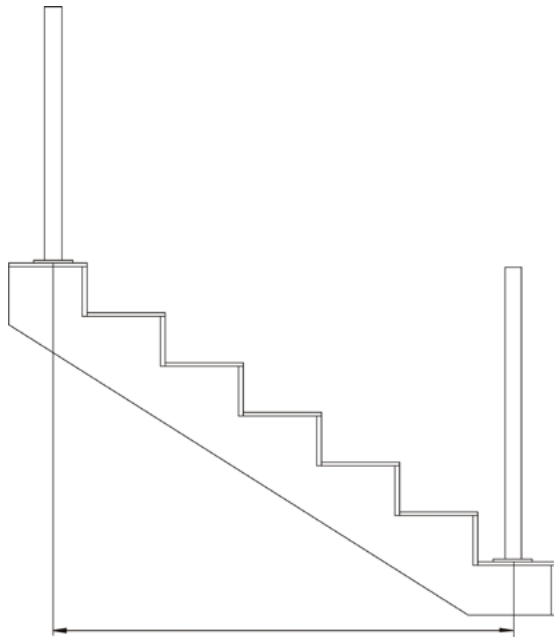

DIAGRAM 1

- 2 Cut post mount (J-R0221-36), which will be placed on the top, to the length of $36 \frac{4}{5}$ " (937 mm) as shown in diagram 2. The post mount on the lower side DO NOT need to be cut.

Cut the post sleeve (N-UH35), which will be placed on the top, to the length of 39" (991mm) as shown in diagram 3. The post sleeve on the lower side DO NOT need to be cut.

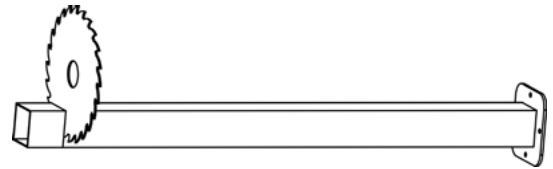

DIAGRAM 2

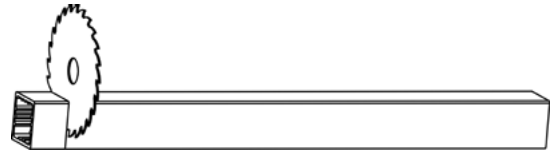

DIAGRAM 3

- 3 Install the post mount (J-R0221-36) as shown in diagram 4-20.

Note: Screw WJ0094 is used when installed on concrete. Screw WJ0161 is used when installed on deck.

Installing the Post Mount on a Concrete Surface

a. First position the post with the metal base in the position of installation. Then use a marker or pencil to mark the drilling hole positions as shown in Diagram 4.

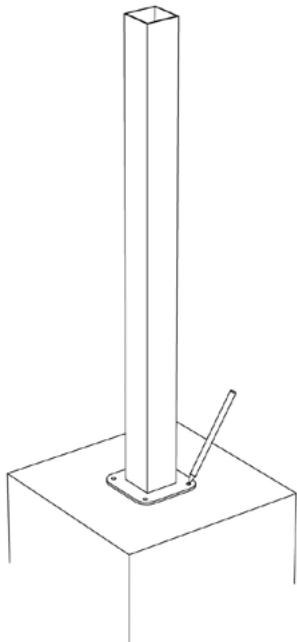

DIAGRAM 4

b. Now take a drill and drill in the spots marked previously as shown in Diagram 5.

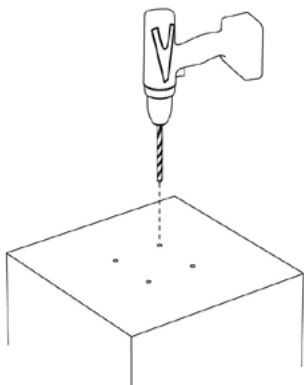

DIAGRAM 5

c. Insert the plastic anchors into the drilled holes as shown in Diagram 6.



Φ12 X 75

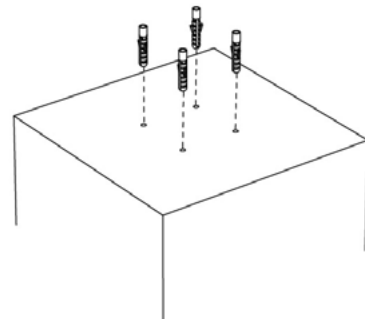

DIAGRAM 6

d. Position the post with the metal base over the predrilled holes and then insert the screws (T-WJ0094) into the designated holes as shown in Diagram 7.



T-WJ0094

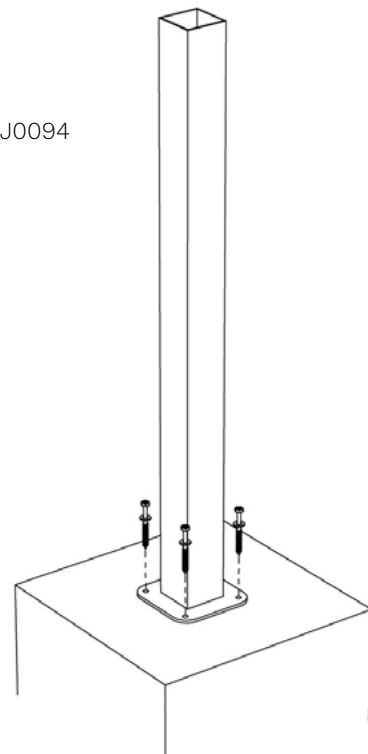

DIAGRAM 7

e. Now fix and tighten each screw, once complete it should look like Diagram 8.

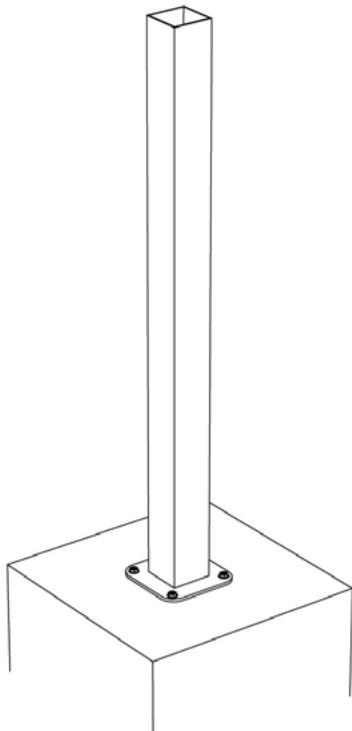

DIAGRAM 8

f. Install the post sleeve (N-UH35) as shown in Diagram 9.

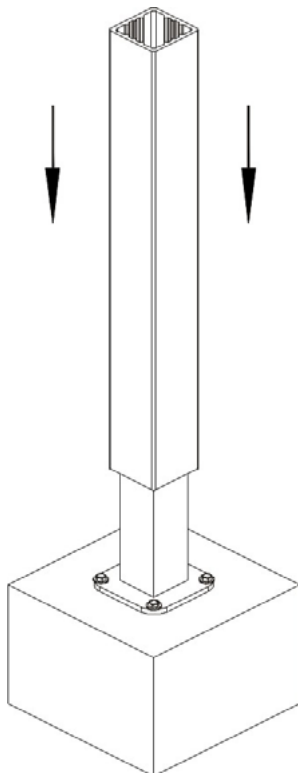

DIAGRAM 9

g. Put the post skirt over the post sleeve as shown in Diagram 10.

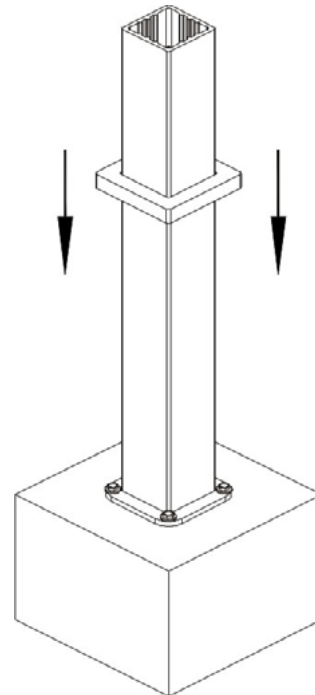

DIAGRAM 10

h. Then put the post cap on top of the post sleeve as shown in Diagram 11.

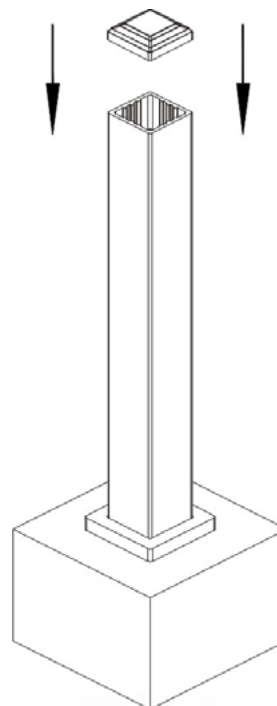

DIAGRAM 11

Installing the Post Mount on a Deck

a. Following Diagram 12, 13 position the post with the metal base.

Note: Installing directly on the board requires a substrate underneath in order for the screws to fully secure the board, ensure careful attention is paid to Diagram 12, 13.

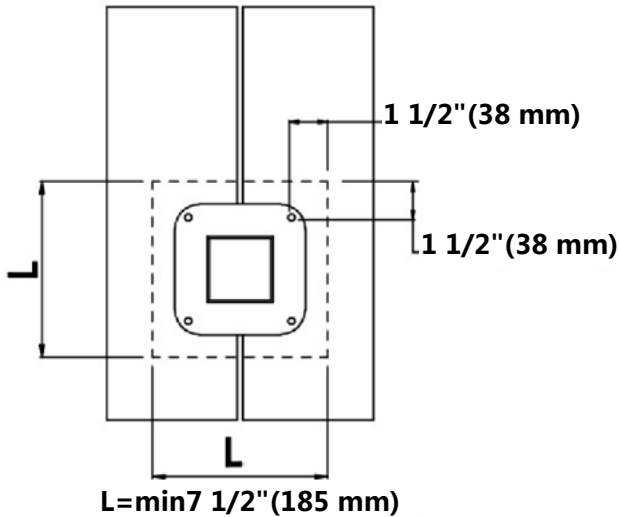
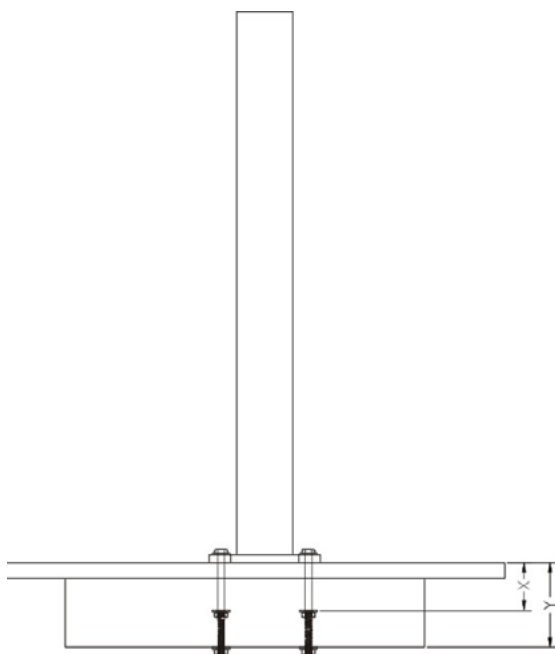

DIAGRAM 12



$X \geq 2 \frac{11}{20}''$ (65 mm)

$Y \leq 4 \frac{1}{2}''$ (115 mm)

DIAGRAM 13

Note: The substrate underneath has to fit in between the range shown in Diagram 13.

b. Once the post is in the correct position mark the holes with a marker or pencil as shown in Diagram 14.

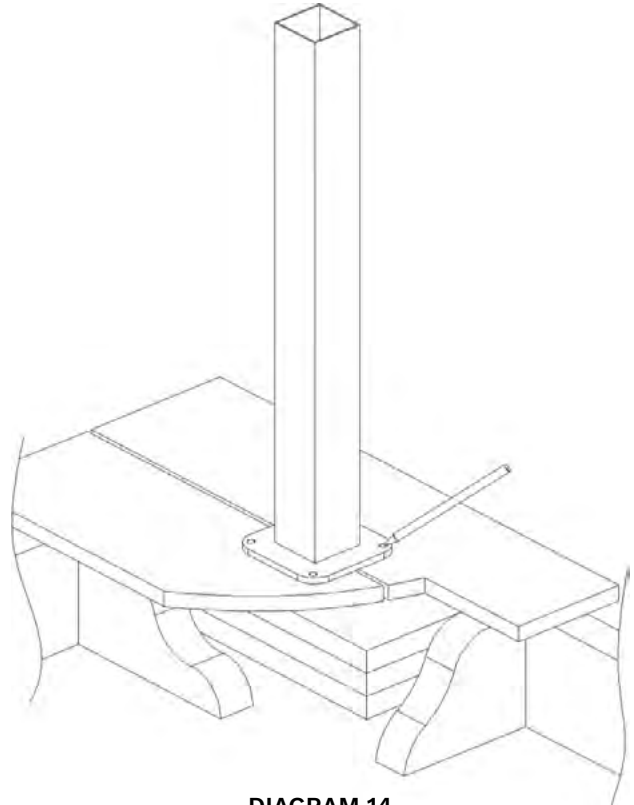

DIAGRAM 14

c. Now take a drill and drill the holes previously marked as shown in Diagram 15.

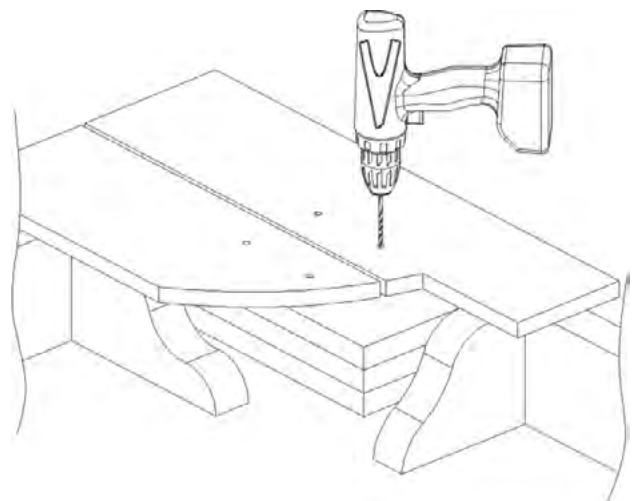

DIAGRAM 15

d. Put the post back over the predrilled holes and insert the screws (U-WJ0161) lag bolts into place as shown in Diagram 16.

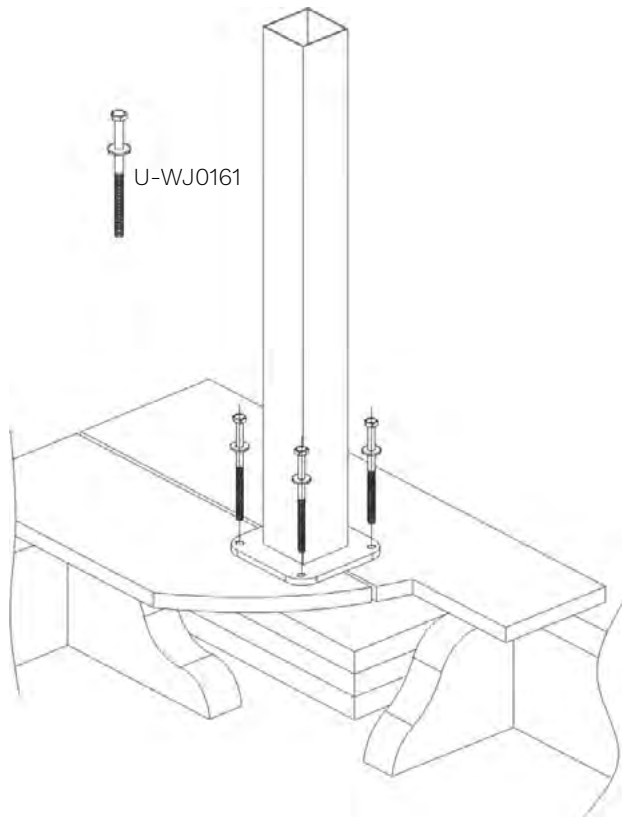

DIAGRAM 16

e. Tighten the lag bolts with washers underneath the substrate as shown in Diagram 17.

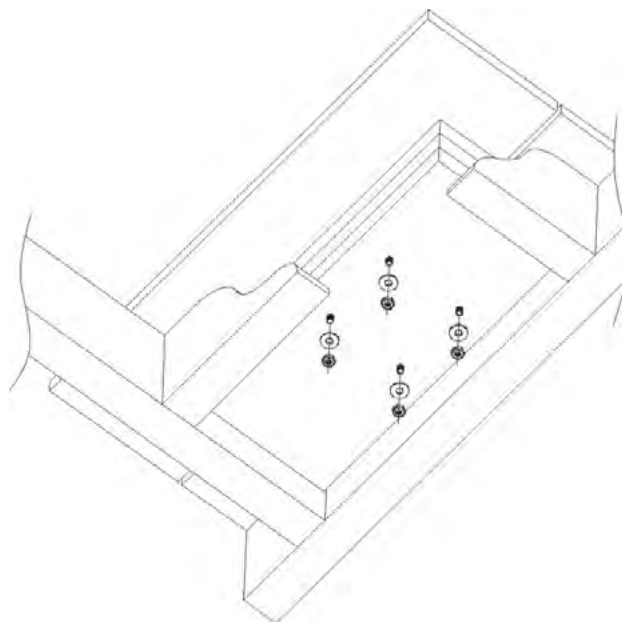

DIAGRAM 17

f. The composite post can now be put over the metal insert as show in Diagram 18.

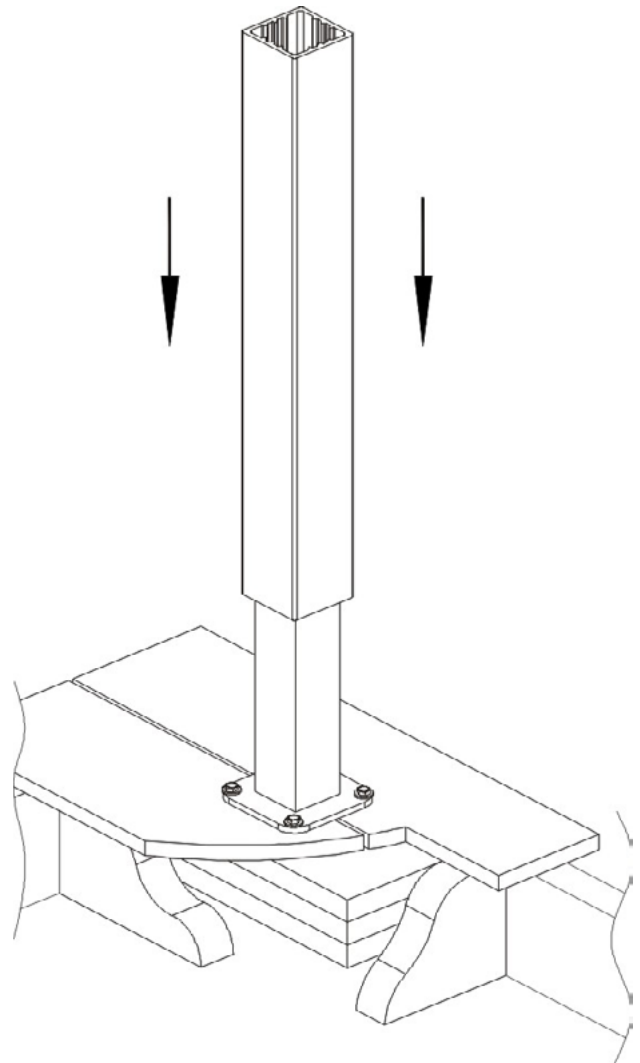

DIAGRAM 18

g. Finally take the post skirt and put it over the composite post to cover the bottom of the metal insert as shown in Diagram 19. Then take the post cap and cover the top of the composite post as shown in Diagram 20.

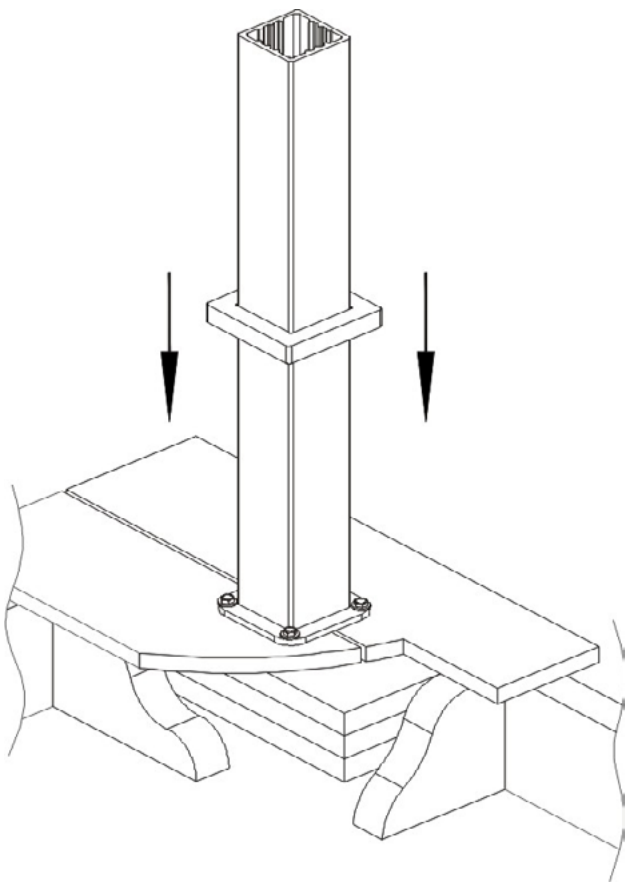

DIAGRAM 19

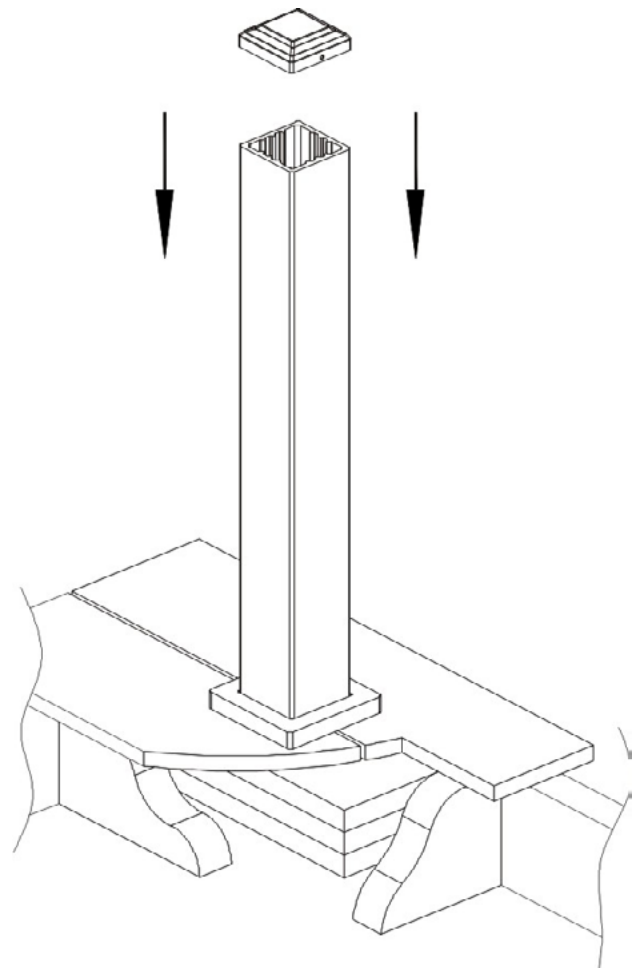

DIAGRAM 20

Stair Railing Installation Continued

- 4** First, mark on the post which will be on the stair top using the "Stairs - Top Post" cardboard template. Use the top 4 holes for top post brackets and use the bottom 2 holes for the bottom post brackets.

Then, pull a string down at a 32 degree angle for locating the "Stairs - Bottom Post" cardboard template on the stair bottom post as shown in diagram 21.

Note: The cardboard template location should be measured from the bottom.

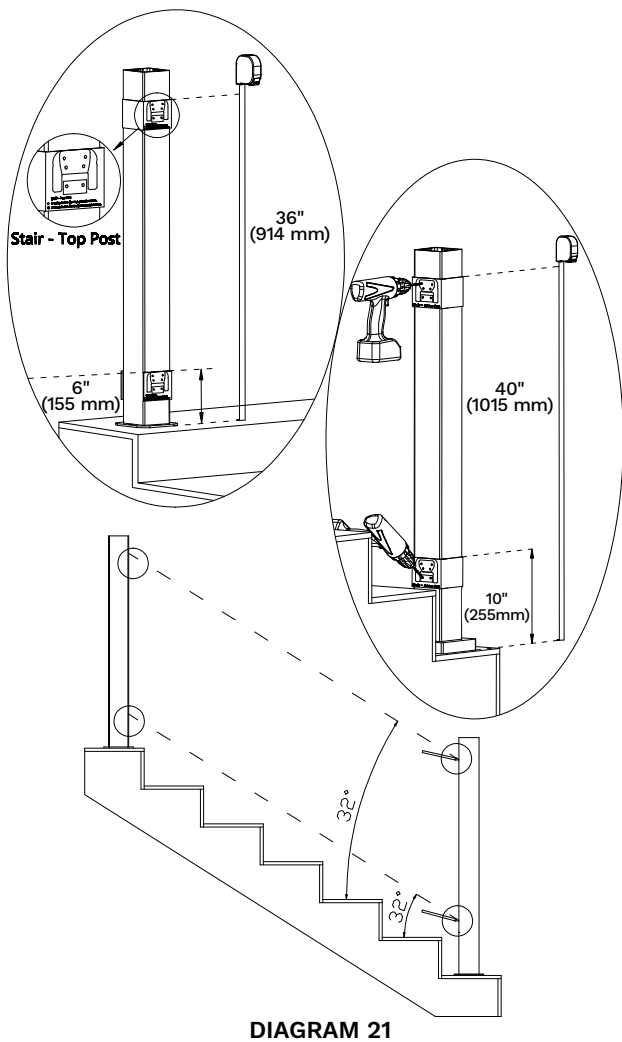

- 5** Pre-drill post bracket holes with a 7/64 inch (3mm) bit as shown in diagram 22.

Lower the post skirt (K-LV-0119) over the post sleeve (N-UH35) as shown in diagram 23.

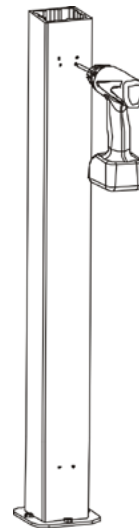

DIAGRAM 22

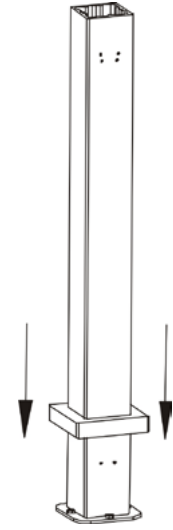

DIAGRAM 23

- 6** Drill in the top post brackets (D-R0225) with screw (P-WJ0130) as shown in diagram 24.

Drill in the bottom post brackets (G-R0205) with screw (Q-WJ0131) as shown in diagram 25.

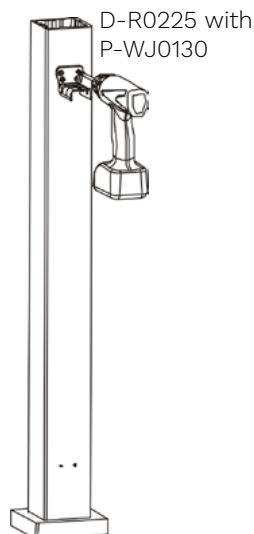

DIAGRAM 24

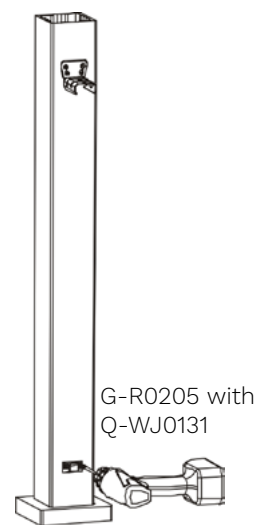

DIAGRAM 25

- 7 Cut rails (A-UR02) to the length (L1 in diagram 26) between the post sleeve (N-UH35) minus 7/64" (3 mm) on each side for inserting gaskets at a 32 degree angle. L1 can be measured like L minus 7/64" (3 mm) on each side.

Remember to take out galvanized insert (B-R0224-1) before cutting rail (A-UR02). The galvanized insert (B-R0224-1) should be cut 6/25" (6 mm) shorter than the rail (A-UR02).

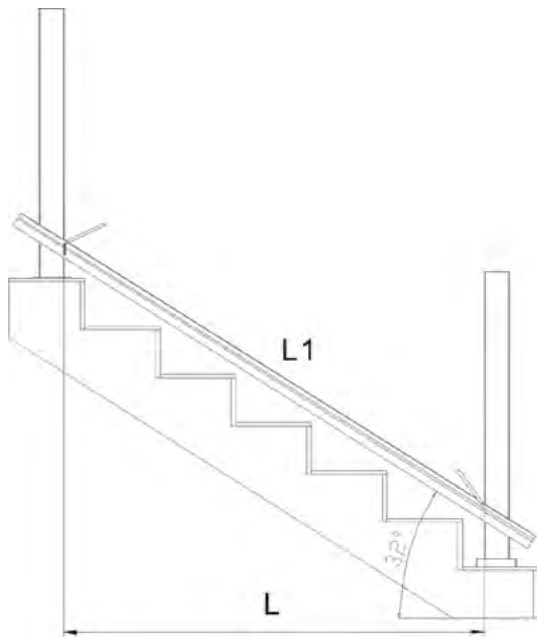

DIAGRAM 26

Note: Need to leave at least 3 1/5" (83 mm) between the ends of the rail and the first hole of each end as shown in diagram 27.

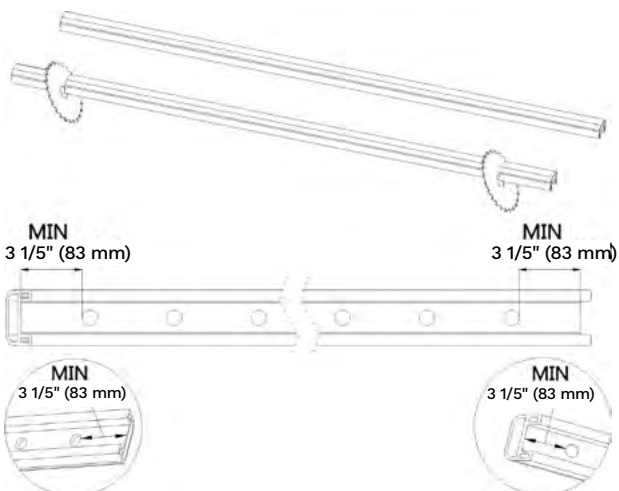

DIAGRAM 27

The galvanized insert (B-R0224-1) is designed for a maximum of 72" (1825.7 mm) as shown in diagram 28.

The railing is designed for a maximum of 73" (1857.5 mm) as in diagram 29.

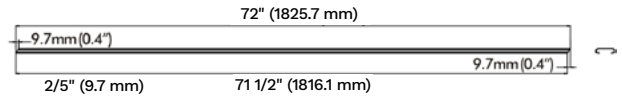

DIAGRAM 28

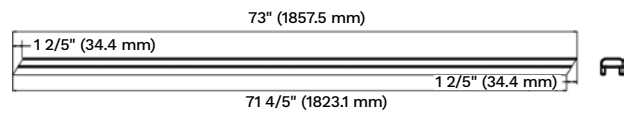

DIAGRAM 29

- 8 The bottom bracket (H-R0204) should be installed with screw (S-WJ0149) at 1 3/10" (32.5 mm) and 1" (24 mm) from the end of the rail which will be placed on the higher side of the stairs as shown in diagram 30. The bottom bracket (H-R0204) should be installed with screw WJ0149 at 1 1/10" (28 mm) and 1" (24 mm) from the end of the rail which will be placed on the lower side of the stairs. Alternatively, a flat board can be used to press the bracket up against the end of rail to line up the correct distance.

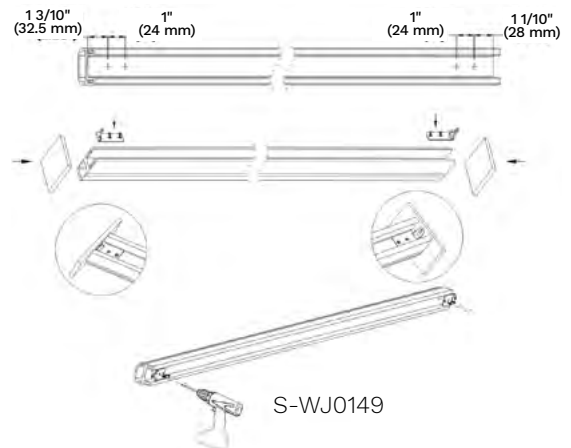

DIAGRAM 30

- 9 Pre-drill and install the foot blocks (I-R0217) with screw (S-WJ0149) on the bottom rail as shown in diagram 31. Foot blocks should be evenly spaced out depending on the length of the final rail and cannot be installed underneath a pre-drilled baluster hole.

Note: Top rail is A in diagram 32. The holes should be facing downwards. Bottom rail is B in diagram 32. The holes should be facing upwards.

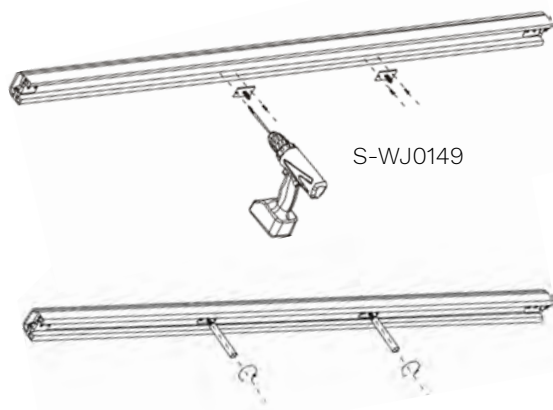

DIAGRAM 31

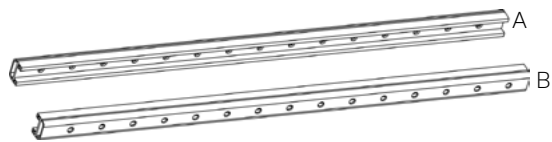

DIAGRAM 32

- 10 Attach the galvanized adaptors (C-R0224-2) on both ends of the galvanized insert (B-R0224-1) as shown in diagram 33.

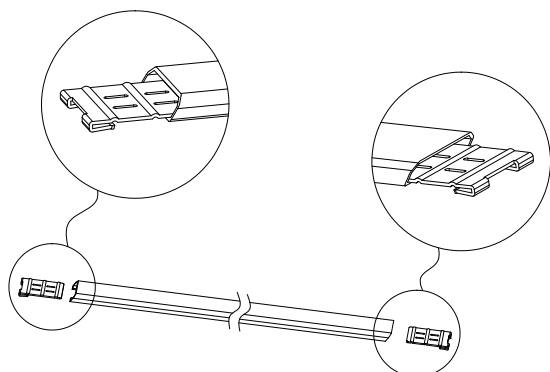

DIAGRAM 33

- 11 Slide the galvanized insert (B-R0224-1) into the top rail (A-UR02) as shown in diagram 34.



DIAGRAM 34

- 12 Cut aluminum balusters (M-R0218-36) to the length of 28" (703 mm) as shown in diagram 35.



DIAGRAM 35

- 13 Attach the bottom rail (A-UR02) onto the bottom post brackets (G-R0205) as shown in diagram 36.

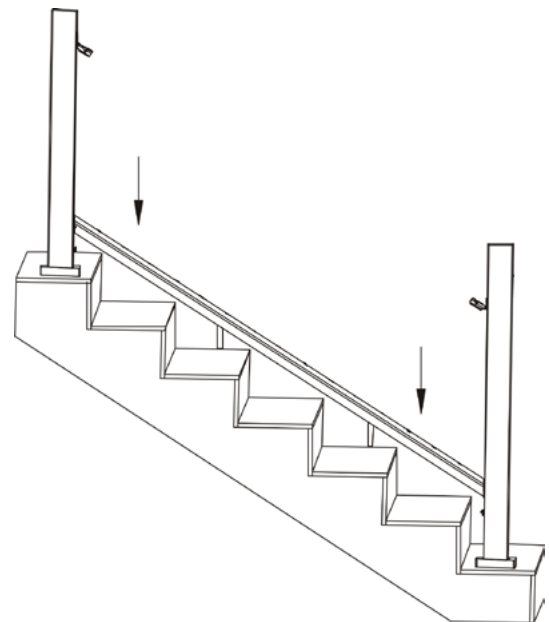

DIAGRAM 36

- 14 Install the baluster plugs (E-LV-0218-C) and aluminum balusters (M-R0218-36) as shown in diagram 37.

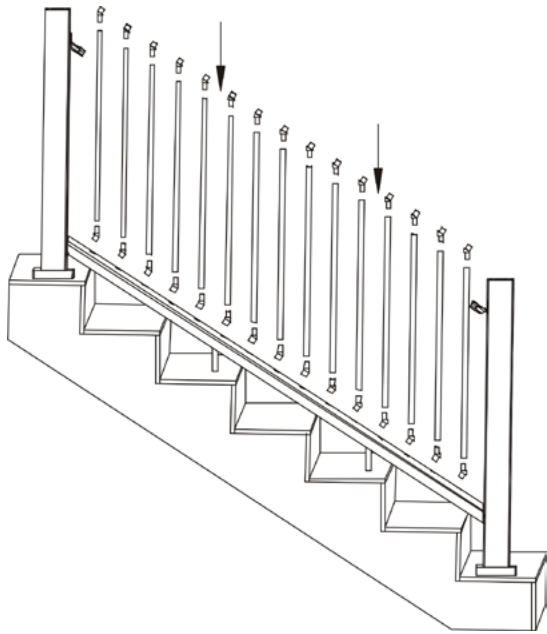

DIAGRAM 37

- 15 Attach the top rail (A-UR02) to the top brackets (D-R0225) as shown in diagram 38.

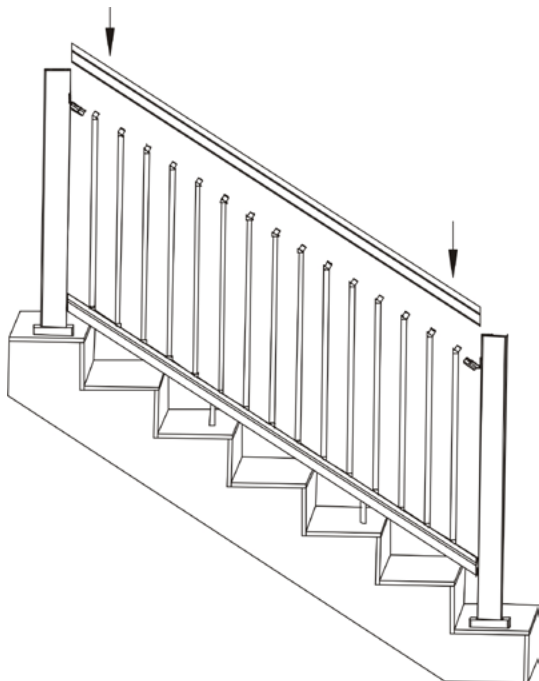

DIAGRAM 38

- 16 Pre-drill and install with screw (R-WJ0143) as shown in diagram 39.

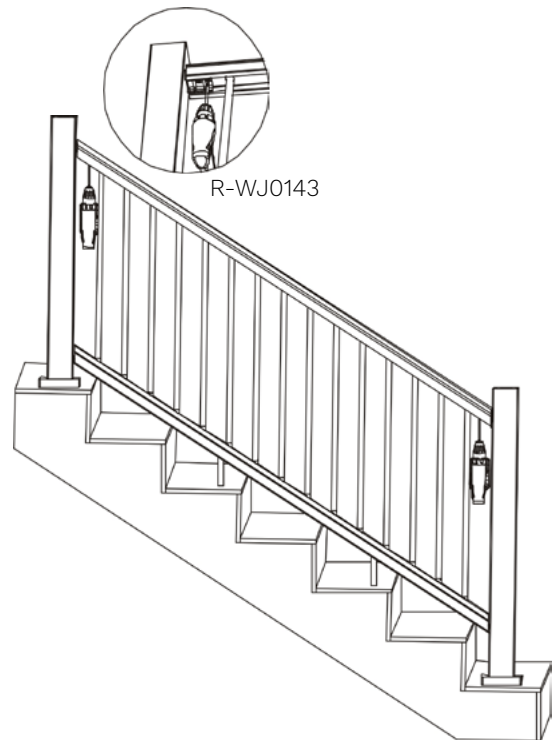

DIAGRAM 39

- 17 Install the post cap (L-LV-0120) and gaskets (F-R0113, O-R0115) as shown in diagram 40.

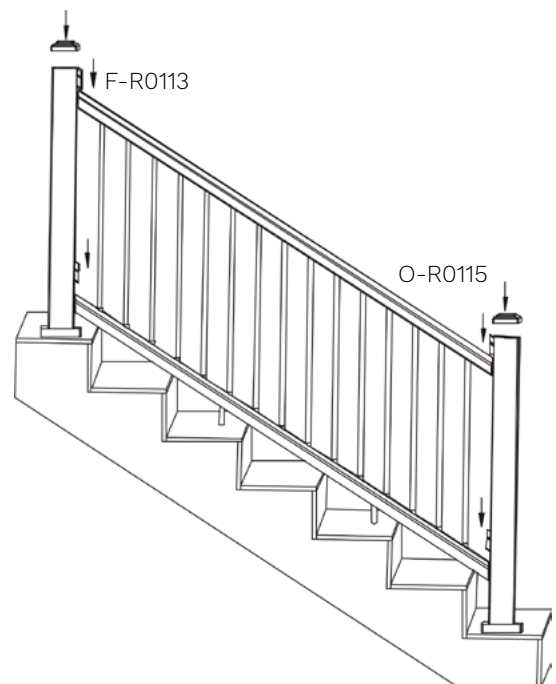

DIAGRAM 40

- 18** If needed adjust the foot blocks (I-R0217) to the correct height as shown in diagram 41.

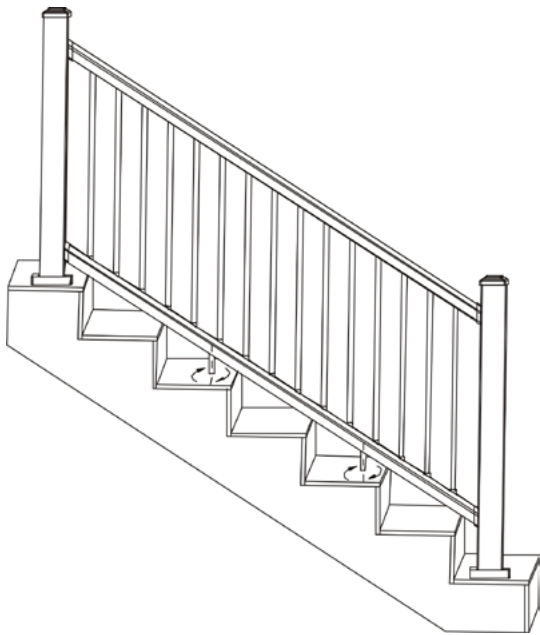

DIAGRAM 41

- 19** Install the post cap (L-LV-0120) with screw (V-WJ0153) as shown in diagram 42.

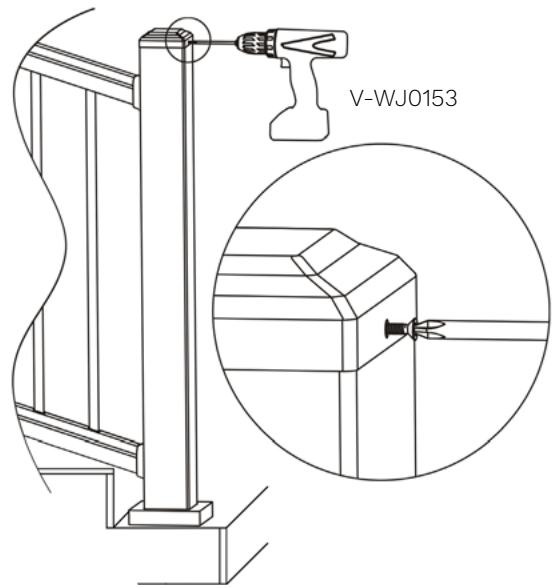

DIAGRAM 42



36" Hybrid Composite Railing Installation Guide

v20200618

©2020 Huidong Meixin Plastic Lumber Products Manufacturing Co., Ltd.
NewTechWood® is a registered trademark of Huidong Meixin Plastic Lumber Products Manufacturing Co., Ltd. To obtain a copy of the most current version of this installation guide, visit us online at www.newtechwood.com.

