



Professional speaker system

PAGAZ 441

The PAGAZ series is a highly weather-resistant, 4" ,2-way full range loudspeaker, fitted with one HF driver, the body is made of aluminum alloy, conforms to IP56 international standard.

FEATURES

- Highly weather-resistant IP56 rating
- Light weight aluminum alloy enclosure
- Two kinds of mounting brackets
- Good used for meeting rooms, shops, water parks,outdoor background music, swimming pools, and a wide variety of other outdoor or indoor background music



Overall dimensions

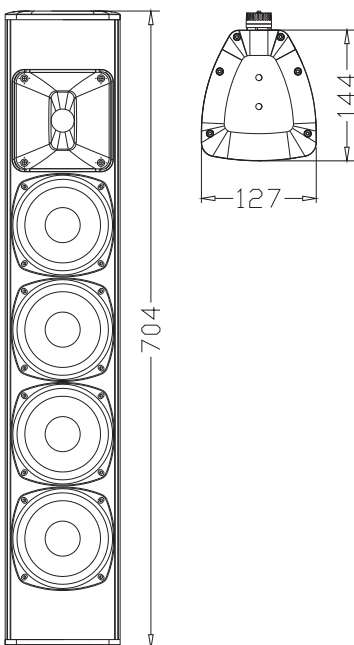

Technical specifications

FREQUENCY RESPONSE(-10dB)	90Hz-18kHz
DRIVERS	4×4"(100mm)/1"voice coil LF 1×1"(25mm)/ 1.4"voice coil HF
RATED POWER	130W RMS,520W peak
SENSITIVITY	94dB 1watt/1 metre
MAXIMUM SPL	115dB continuous,121dB peak
IMPEDANCE	8 ohms nominal
DISPERSION(-6 dB)	100 ° ×50 °
CROSSOVER FREQUENCIES	1.9KHz passive
INPUT CONNECTORS	M22-2P
DIMENSIONS	(W)127mm×(H)704mm×(D)144mm
WEIGHT	8.5kg/pc