

Top View

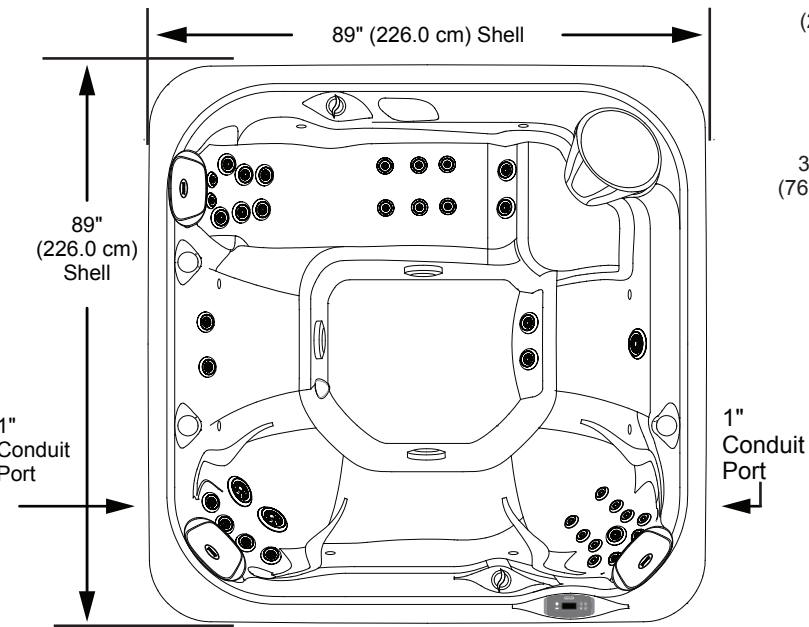

FRONT VIEW

Tolerance: $\pm 0.5"$ (1.27 cm)

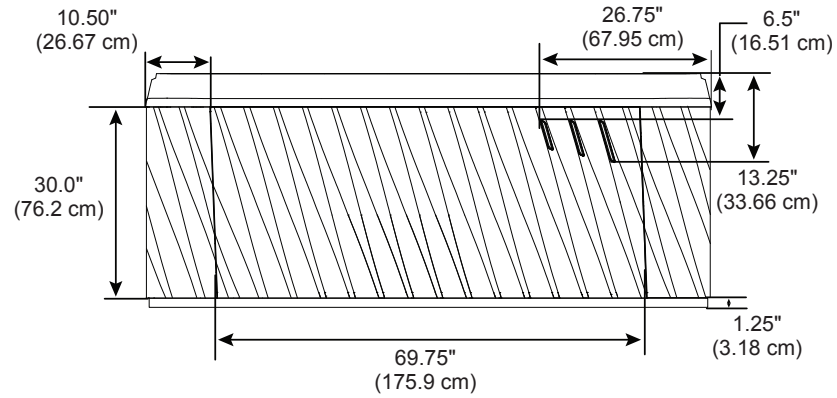

RIGHT SIDE VIEW

Tolerance: $\pm 0.5"$ (1.27 cm)

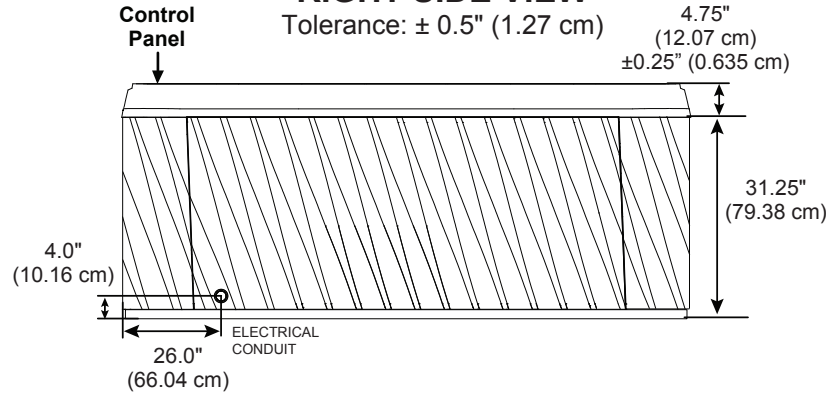

IMPORTANT! Always measure each hot tub for exact dimensions BEFORE designing its foundational support and/or decking.



Cabinet Radius:
 $\approx 10.0"$ (20.32 cm)

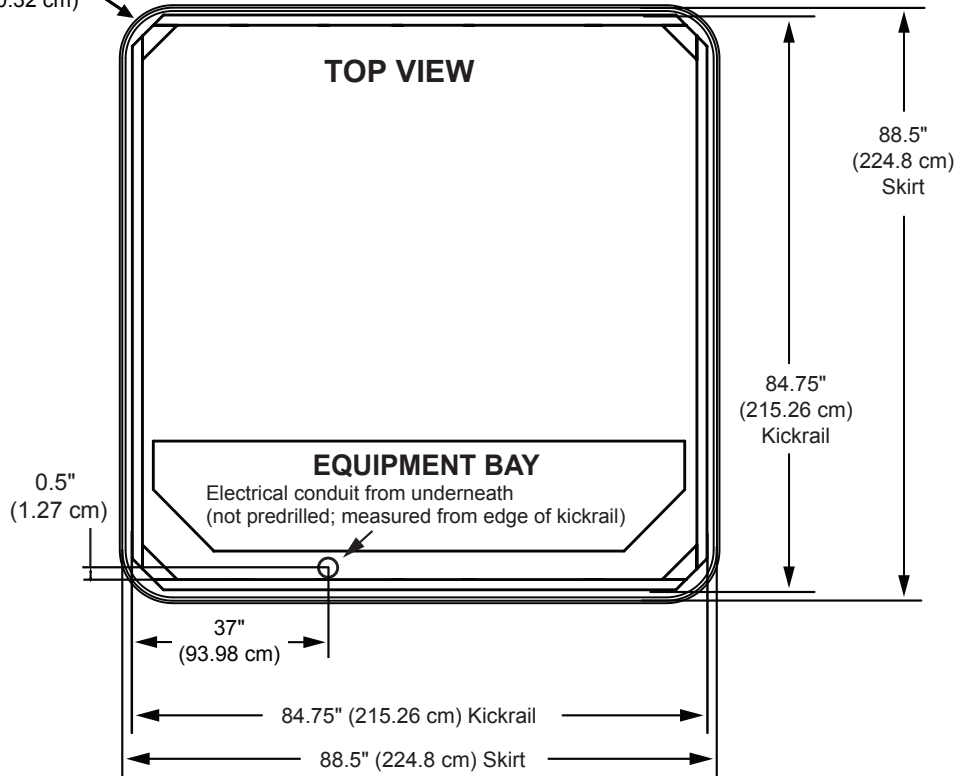

Dimensions/specifications subject to change without notice. Tolerance: $\pm 0.5"$ (1.27 cm)