

95-715-1

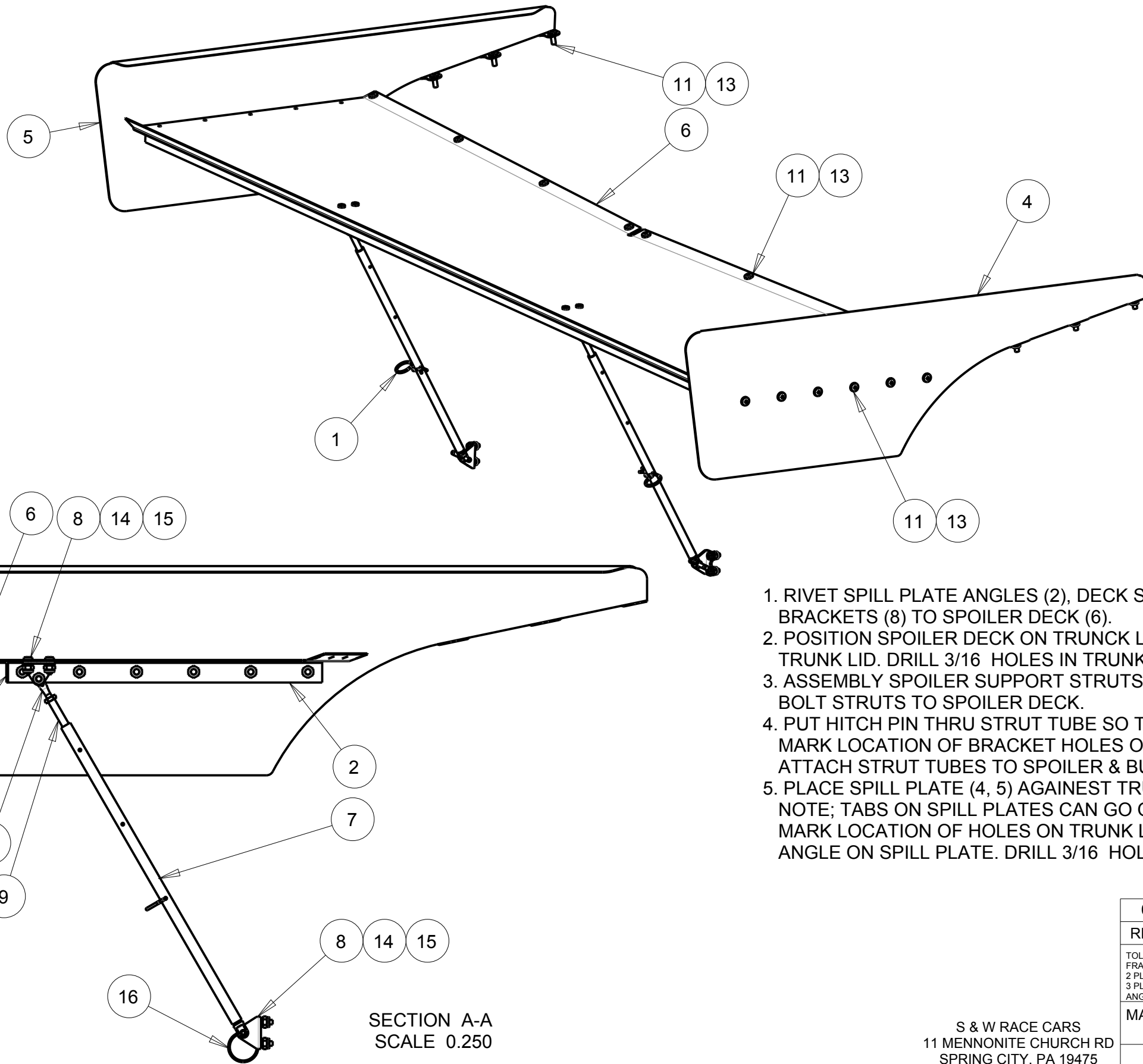

BILL OF MATERIALS

ITEM	QTY	PART No.	DESCRIPTION
1	2	HPC102	3/32 HITCH PIN
2	2	95-715-04	SPILL PLATE ANGLE
3	1	95-715-03	STIFFENER - DECK
4	1	95-715-02_R	SPILL PLATE
5	1	95-715-02_L	SPILL PLATE
6	1	95-715-01	SPOILER DECK
7	2	95-702-03	OUTER TUBE
8	4	95-702-02	WING STRUT MNTG BRKKT
9	2	95-702-01	SLIDER TUBE
10	2	65-512	10-32 X 5/8 SCREW
11	26	65-511	10-32 X 1/2"
12	2	65-508	10-32 HEX NUT
13	25	65-507	10-32 NYLOCK NUT
14	8	65-505	8-32 X 1/2"
15	8	65-503	8-32 NYLOCK NUT
16	2	63-069	3/16 DETENT PIN
17	2	63-067	10-32 THREADED CLEVIS

1. RIVET SPILL PLATE ANGLES (2), DECK STIFFENER (3) & STRUT MNTG BRACKETS (8) TO SPOILER DECK (6).
2. POSITION SPOILER DECK ON TRUNK LID. MARK LOCATION OF HOLE ON TRUNK LID. DRILL 3/16 HOLES IN TRUNK LID.
3. ASSEMBLY SPOILER SUPPORT STRUTS (7, 9, 17, 12), AND MNTG BRACKETS (8, 16). BOLT STRUTS TO SPOILER DECK.
4. PUT HITCH PIN THRU STRUT TUBE SO THAT BRACKET IS AGAINST FACE OF BUMPER. MARK LOCATION OF BRACKET HOLES ON BUMPER. DRILL 3/16 HOLES IN BUMPER. ATTACH STRUT TUBES TO SPOILER & BUMPER BRACKETS.
5. PLACE SPILL PLATE (4, 5) AGAINST TRUNK LID AND SPOILER DECK ANGLES. NOTE; TABS ON SPILL PLATES CAN GO ON TOP OR BOTTOM OF TRUCK LID. MARK LOCATION OF HOLES ON TRUNK LID. MARK LOCATION OF HOLES IN SPILL PLATE ANGLE ON SPILL PLATE. DRILL 3/16 HOLES IN TRUNK LID & SPILL PLATE.

SECTION A-A
SCALE 0.250

S & W RACE CARS
11 MENNONITE CHURCH RD
SPRING CITY, PA 19475

REV	DATE	JEB DRN	DESCRIPTION
0	24JUL15	JEB	INITIAL RELEASE
TOLERANCES: FRACTIONS ±1/32 2 PLC DEC ±0.01 3 PLC DEC ±0.005 ANGLES ±0.5°			GM A-BODY SPOILER GENERAL ARRANGEMENT
MAT'L:			
PART No: 95-715			DRW No: 95-715 - 1

95-715-2

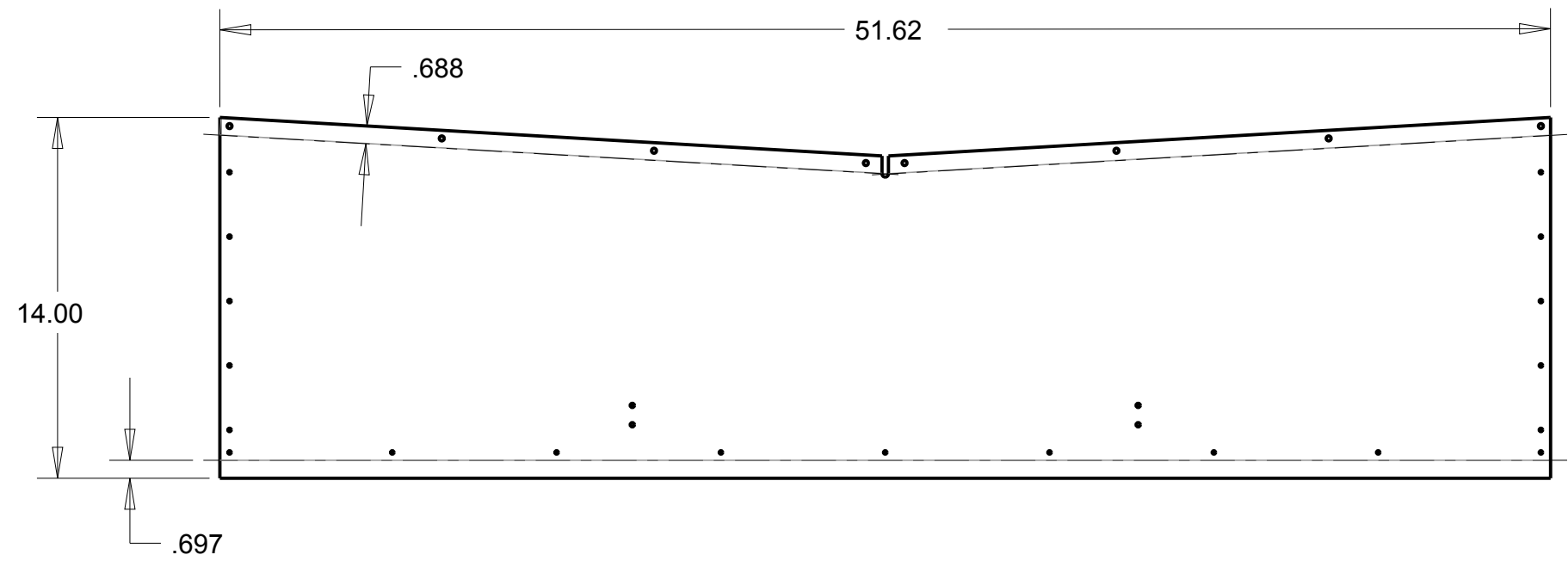

FLAT PATTERN
SCALE 0.156

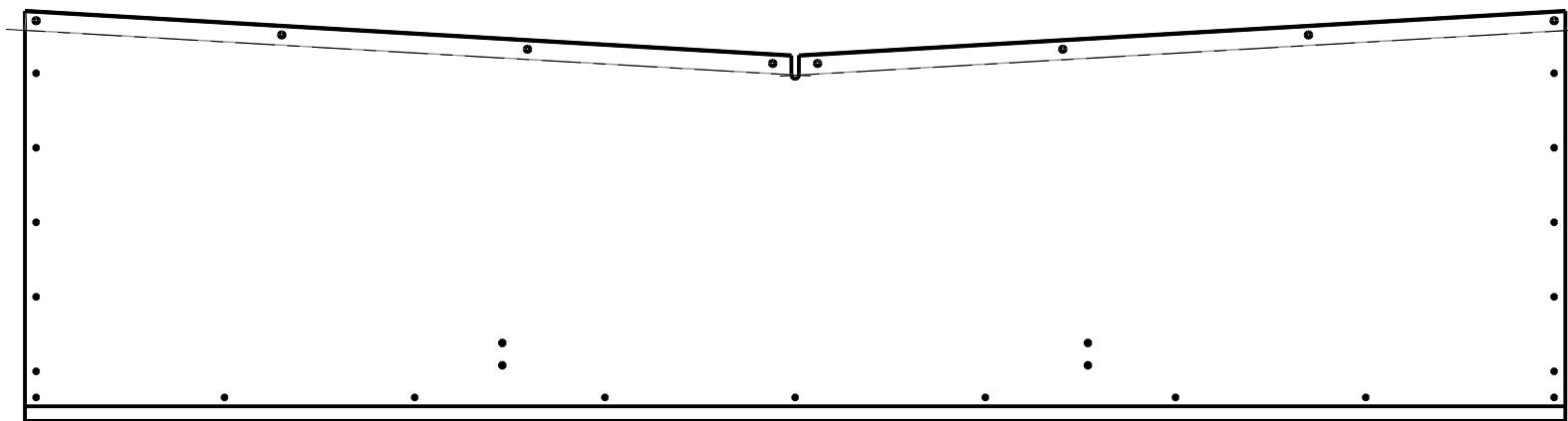

SCALE 0.156

S & W RACE CARS
11 MENNONITE CHURCH RD
SPRING CITY, PA 19475

REV	DATE	DRN	DESCRIPTION
0	15JUL15	JEB	SPOILER DECK
TOLERANCES: FRACTIONS ±1/32 2 PLC DEC ±0.01 3 PLC DEC ±0.005 ANGLES ±0.5°			DETAILS
MAT'L:			
PART No: 95-715-01			DRW No: 95-715 - 2

95-715-3

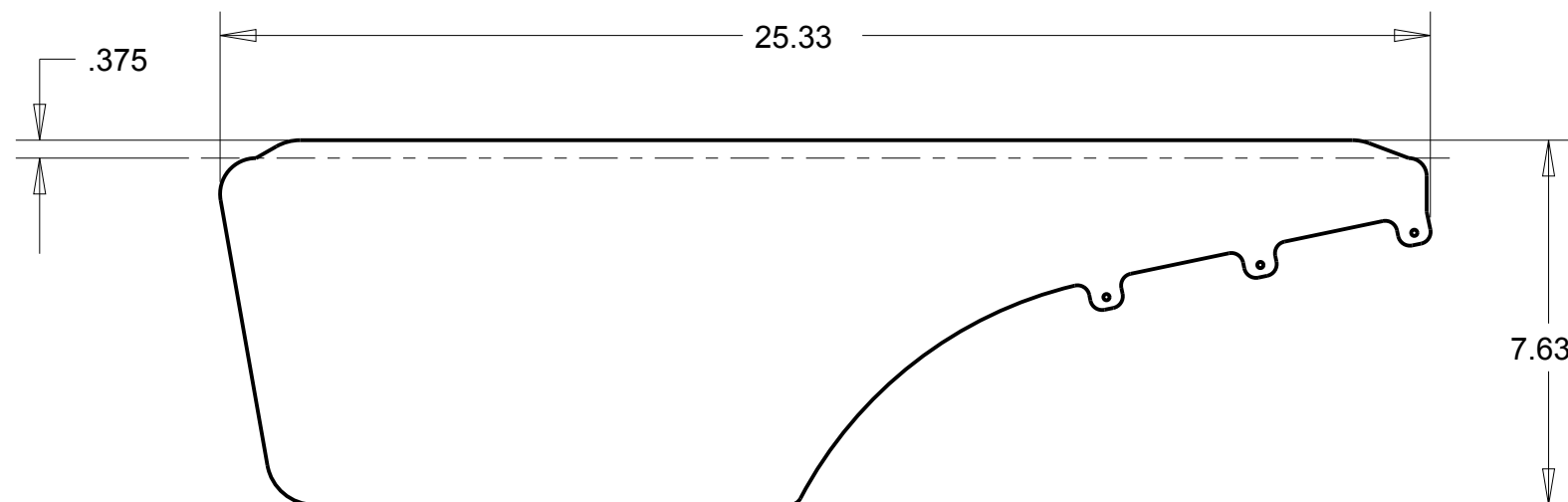

SCALE 0.250

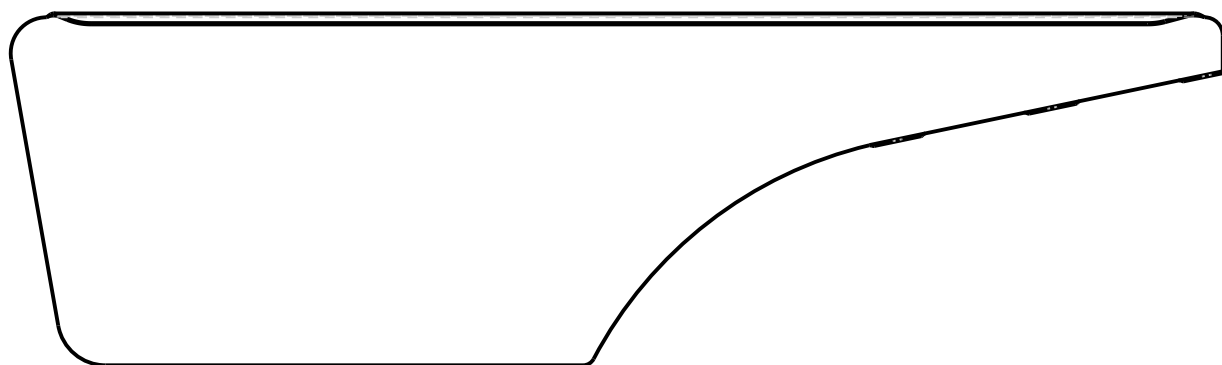

SCALE 0.250

AAA

S & W RACE CARS
 11 MENNONITE CHURCH RD
 SPRING CITY, PA 19475

REV	DATE	DRN	DESCRIPTION
0	ddmmyy	JEB	
TOLERANCES: FRACTIONS $\pm 1/32$ 2 PLC DEC ± 0.01 3 PLC DEC ± 0.005 ANGLES $\pm 0.5^\circ$			SPILL PLATE DETAIL
MAT'L:			
		PART No: 95-715-02_L	DRW No: 95-715 - 3

95-715-4

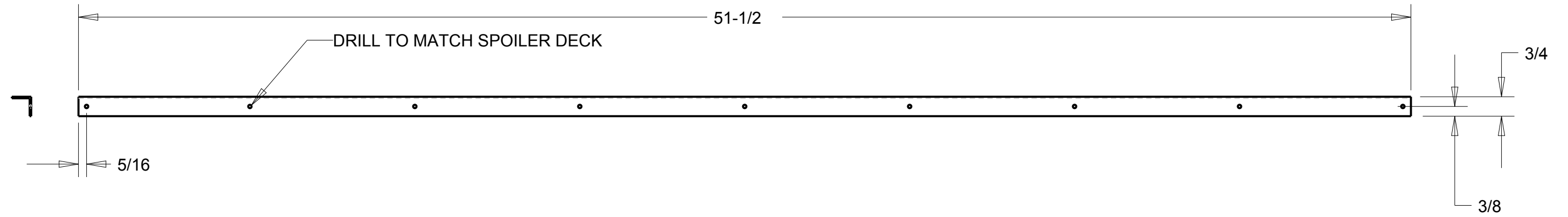

95-715-03
STIFFENER - DECK
SCALE 0.250

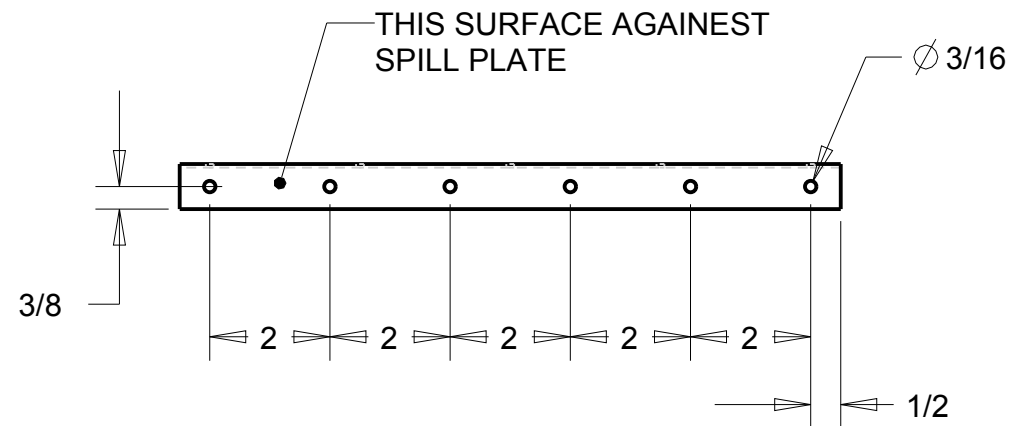
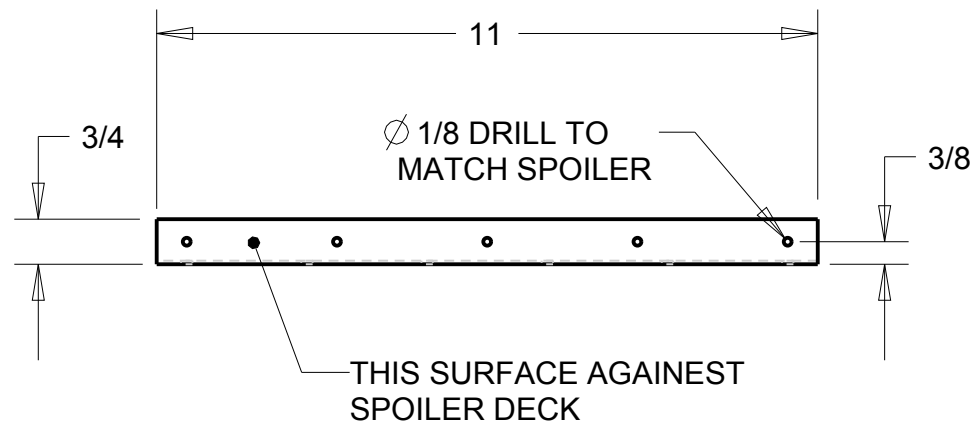

95-715-04
SCALE 0.313

S & W RACE CARS
11 MENNONITE CHURCH RD
SPRING CITY, PA 19475

0	15JUL15	JEB	
REV	DATE	DRN	DESCRIPTION
TOLERANCES: FRACTIONS ±1/32 2 PLC DEC ±0.01 3 PLC DEC ±0.005 ANGLES ±0.5°			DETAILS
MAT'L: ALUM			
PART No:			DRW No: 95-715 - 4