

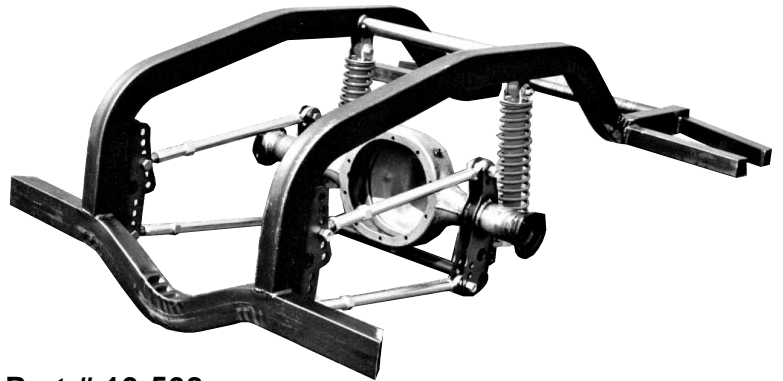

11 Mennonite Church Rd. • Spring City, PA 19475

Tech & Info 610-948-7303 • Orders Only 1-800-523-3353
24 Hour Fax 610-948-7342 • E-Z Info FAX 610-792-1234



**INSTALLATION INSTRUCTIONS FOR Part # 10-508
78-83 MALIBU, 78-88 MONTE CARLO & BUICK GRAND NATIONAL
WELDED 4-LINK REAR FRAME**

Read all instructions carefully before beginning installation

CAUTION!!! - The most important requirement for a successful installation of this, or any, S&W chassis component is that you take your time and use good common sense. Check & recheck all measurements before cutting or welding. If at any time, before or during the installation, you have any questions - STOP - and call our tech line at 610-948-7303 and we will gladly explain in more detail any step in the installation.

Installing a welded frame unit into a clean stock car is a relatively easy job, although there are certain precautions that should be taken for your safety, and to insure that the finished product is properly aligned. It is recommended that you wear eye protection during the removal of the stock floor, suspension and other components, and during welding and fabrication. Proper supports and jack stands must be used, not only for construction purposes (such as keeping the chassis level), but also for safety reasons. This work should be performed in a dry, well lit shop with a level or near-level floor.

While installing your welded frame unit, remember that the quality of your workmanship will directly affect the ultimate strength of the entire race car structure. It is important that all areas to be welded are clean, free of oil, slag, paint, undercoating, and of course rust.

Quality work requires the proper tools. Here is a list of some of the tools you will need.

- A. Common hand tools - for removing the stock suspension components and car interior.
- B. Jack stands - Minimum 6 - for supporting the car and new frame unit.
- C. Floor jack - for raising the car, removing the rear housing and raising the new welded frame unit into place.
- D. Measuring tools - 12' tape measure, level, inclinometer, plumb bob, string, large framing square, felt tip pen or soap stone.
- E. Cleaning tools - gasket scrapers and wire brush to remove undercoating.
- F. Cutting tools - Oxy-acetylene torches, hand-held reciprocating saw or rotary grinder with a cutting disc.
- G. Welding equipment - a MIG welder is recommended. TIG welding is acceptable, but is unnecessary for this type of work.

**Warning: As of Jan. 1, 1995 stick welding is prohibited by NHRA.
S&W Race Cars strongly suggests that these components not be stick welded!**

- 1) With all stock components still in the car, measure and record the wheelbase and mark the rear axle centerline on the car body, directly above the wheel opening.
- 2) Raise the car to a comfortable working height, and level front to back and side to side. This can be done front to back by placing the inclinometer or level on the rocker panel. Level the car side to side by placing the level on the front crossmember and on a horizontal floor panel at the rear of the car. **(See tech notes #1 & #2)**
- 3) In order to insure that you locate the welded rear frame unit properly in the car you must determine the chassis centerline (C/L). This reference is critical when it comes time to center the frame and rear suspension under the car. The chassis C/L is the midpoint line that runs the length of the car. To find the C/L, drop a plumb line from the same two points on opposite sides of the car to the shop floor. Do this at the front and rear of the car. We suggest using the front control arm mounting points and the seam between the rear of the rocker panel and quarter panel. Now measure half the distance between each set of plumb line marks on the floor. Each of these half distances can be connected and a straight line can be drawn on the floor running from front to back, which represents the centerline of the car. It is a good idea to drop a plumb line to the centerline on the ground and transfer it into the car by punching marks on a few crossmembers. Now, if you have to move the car or when you do future work, the centerline can be quickly reestablished. The centerline can also be used for suspension alignment work.

- 4) Remove all stock components such as front and rear seats, carpeting and insulation, interior trim panels, rear wheels and tires, rear axle assembly, rear springs and shocks, brake lines, fuel tank and lines (remove electric fuel pump if rear mounted) and any rear mounted electrical components or wires. Remove upper control arm crossmember. **Note: Do not remove the rest of the original frame at this time.**

- 5) Cut out the stock floor and inner wheel wells. **(See Photos #1&2)** This initial construction step is one of the most critical if neat workmanship is going to be accomplished. Throughout the cutting process, keep an eye on the door and body alignment. Any change in the gap or angle of the door to sill clearance will alert you to bending, twisting or drooping of the car. Make a straight cut, 27" forward of the rear axle centerline, across the floor pan, from the inner side of the original frame. **(See photo # 2)** For your own safety, make sure you support the floor during this step. Grind off all welds and slag from the body panels after removing the stock sheet metal. **(See tech notes #2 & 3)**
- 6) It is now time to install the 4-link frame unit. If this step is not done correctly and misalignment occurs, you will have a car which will not launch or drive straight. In future chassis tuning work, you may have to compromise the suspension components to overcome your unsquare race car.

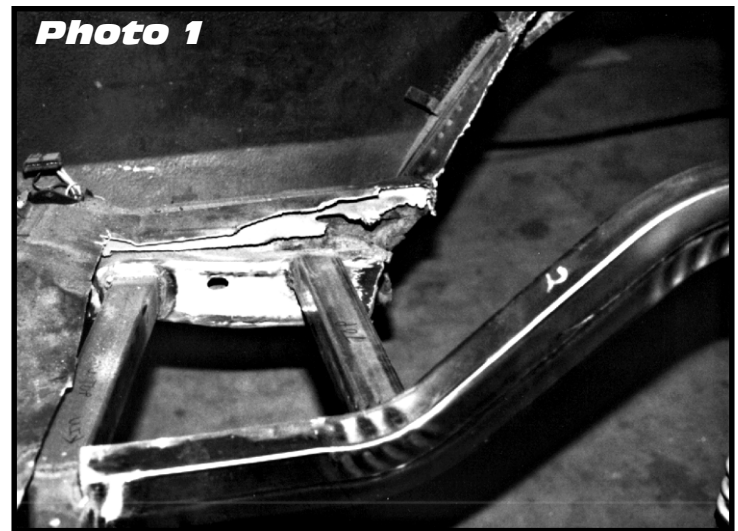

- a) Trial fit the S&W welded 4-link frame unit into the car. **(See photo # 1&3)** Level the frame unit front to back & side to side. Check side to side location using your chassis C/L. Make sure the center of the welded chassis is in line with the chassis C/L. **(See photo #4)**
 - b) If you are satisfied with the installation, tack weld the new S&W frame unit in place. **Tack weld only!!!**
 - c) Recheck the squareness and location of the welded frame unit with the chassis C/L.. With the axle housing, tires and wheels, and 4-link installed at ride height check all clearances. This includes the distance from frame rail to tire and from tire to fender. Refer to instructions included with 4-link, panhard bar or track locator, and shock & spring kit for proper installation of these components.
- 7.) With the welded frame unit tacked in place, the next step is to install the front frame support tubes. These tubes will go from the pads welded on the front crossmember out to the inside surface of the stock frame. Use the tube to determine the location of the frame reinforcement plate. Tack weld plates in at this time. Cut a small access hole in the floor pan, above the plate for ease of welding. Tack weld front frame support tubes at this time. Installation of these components will join the new welded frame unit with the original frame. **(See photo #5)**
 8. To complete the installation of your welded frame, you must install at minimum an 8 point roll bar, or a 10 point roll cage. The installation of a cage or roll bar is not only for your safety, but also to make the complete chassis much stronger.
 9. Remove all suspension components installed in step 6 and finish weld the frame unit as well as the roll bar or roll cage assembly. Finish welding the front frame support tubes to the frame unit and frame reinforcement plates.
 10. Trim the factory frame as needed for the wheel tubs and install the frame cap off plates. **(See photos #6 & 7)**
 11. Reinstall suspension components. Refer to instructions included with 4-link, panhard bar or track locator, and shock & spring kit for proper installation of these components.

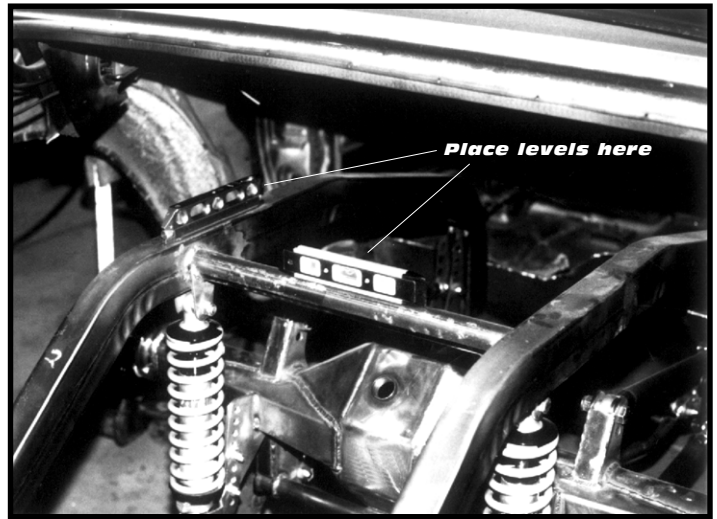

Photo 4



Photo 5

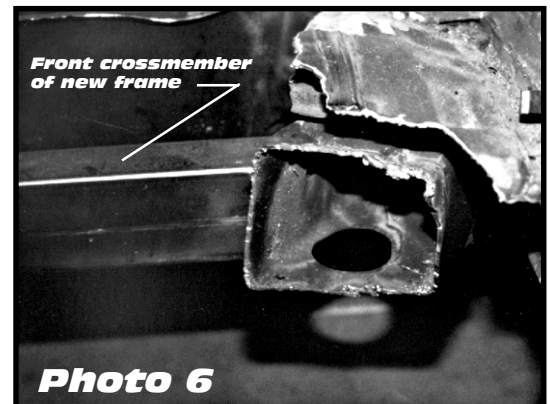

Photo 6



Photo 7

TECH NOTES

- 1) When leveling and supporting the car, be sure to keep it from drooping. If the car is bent while the welded frame unit is being installed, you will have door alignment problems and the potential for pre-load and handling problems.
- 2) Keep the car doors closed during the construction process and position the jack stands to give you the widest base of support possible. With the car raised and level support it at six (6) locations, one of these being the rear bumper area.
- 3) Sparks from cutting, welding and grinding can damage windows. Be sure to sufficiently cover or remove windows to avoid damage.
- 4) From the first step to the last **ALWAYS BE AWARE, AND MAINTAIN THE CAR'S LEVEL CONDITION!!**
The installation of this welded frame unit does not result in a completed chassis! We recommend the installation of at minimum an eight point roll bar before operating the vehicle.

The following parts are available from S&W Race Cars for the 78-83 Malibu, 78-88 Monte Carlo and Buick Grand National and are designed specifically to work in conjunction with your newly purchased rear frame package.

- 11-1016 - 8 point roll bar • 11-1516 - 10 point roll cage • 10-801 Aluminum floor kit • 10-805 Steel floor kit
 - 95-390 38" Alum. wheel tubs • 95-392 40" Alum. wheel tubs • 95-393 38" Steel wheel tubs • 95-394 38" Steel wheel tubs
- Also available - Axles, Studs, Bearings, Assembled Center Sections and Brakes



**Part # 45-1457B
Rear Housing**

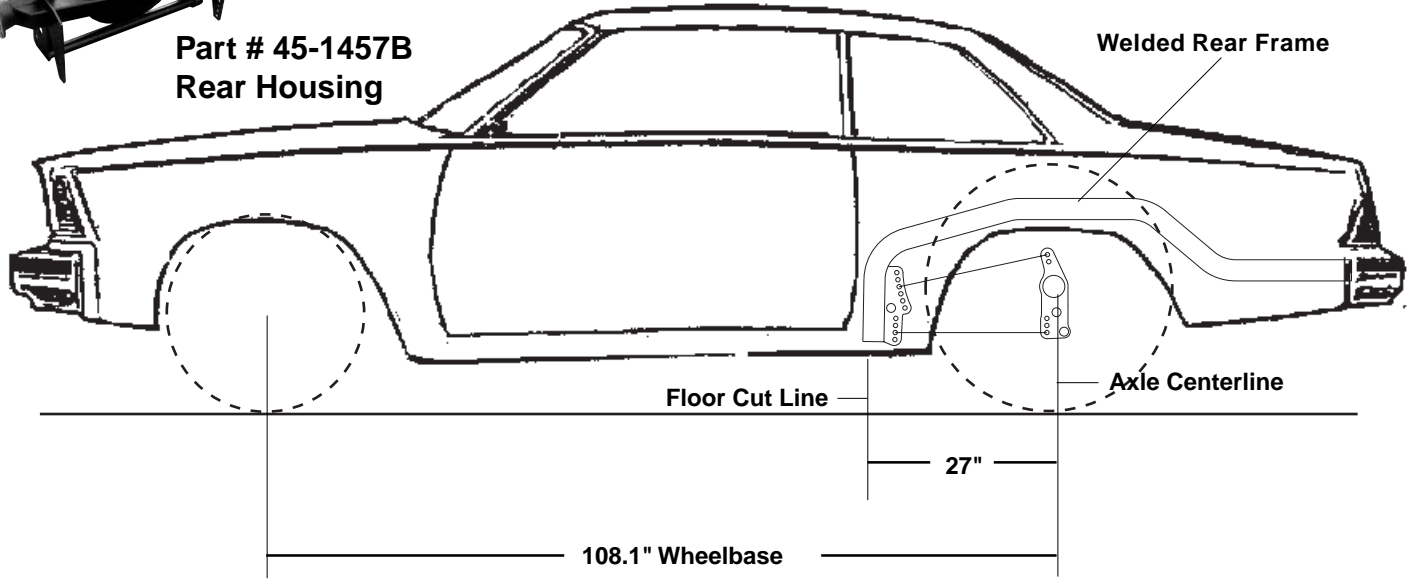

This S&W Race Cars frame package is designed to use wheels and tires with the following dimensions

Wheels - 14" wide with a 4" rear spacing

Tires - 21.5 x 33 Mickey Thompson
- 15 x 33 Goodyear

The rear housing *with axles* should measure 38-1/2" axle flange to axle flange when assembled

Mount all brackets as shown at right.

Optional rear anti roll bar available
Part # 40-000 - \$259.95
Please call for more information

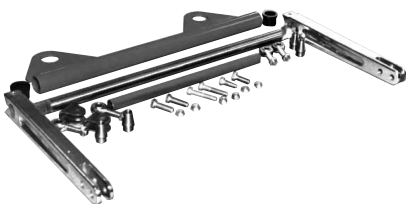

NOTE:
1. CENTERED PINION.
2. HOUSING TO BE JIG WELDED.

