



**64-72 CHEVELLE (2 DOOR) WELDED FRAME UNIT
Part # 10-501**



*These instructions are for the 64-72 2 door chassis!
To use of this frame in 4 door, station wagon,
El Camino or 70-72 Monte Carlo
please see the note on the next page.*



S&W Race Cars & Components, Inc.

11 Mennonite Church Road • Spring City, PA 19475

**TECH & INFORMATION
610-948-7303**

**ORDERS: 1-800-523-3353
FAX: 610-948-7342**

Thank you for purchasing our 64-72 Chevelle Frame Rail Unit. We feel that this is the finest unit available for doing the rear half of your car without major floor modifications.

Note: This frame has been designed for a 64-72 Chevelle, GTO, Cutlass, or Skylark 2 door model only!! Installing this frame in a 4 door, station wagon, El Camino, or 70-72 Monte Carlo requires that the installer use the axle centerline as the frame placement reference point. If you have any questions please call before beginning installation!

Do not cut the stock chassis yet, this will come later

Note: S&W unit installation may be performed with the body mounted on the frame, or with the body removed from the frame. (Whichever best suits your needs.)

S&W Race Cars strongly recommends that at least an 8 Point Roll Bar be Installed with this frame unit. This will intensify the strength and stability of your frame unit, and will keep the body panels from flexing or bowing.

STEP 1

With the car sitting on a level surface, measure & record the wheelbase on both sides of the car and the rear ride height, by measuring from the center of the housing to a reference point on the quarter panel.

STEP 2

Jack up the car, making sure to support the chassis in front of the wheel wells and at the rear bumper.

STEP 3

Cut out the floor in the trunk (Photo 1), you may cut the wheel wells now or later (Photo 2). Now the floor needs to be cut for the front crossmember. Measure from the rear axle center line, front 36", this is where the front edge of the ladder bar crossmember will be and your first cut. Measure in 3-1/2" from the door jam, from this point make a 17" cut towards the center of the car. Measure back 2" to make the second cut through the floor (Photo 3). Finish removing the floor by making cuts to connect the two 17" cuts.

STEP 4

Now you must cut out the stock spring and shock crossmember and the upper and lower control arm mounts. Next clean the dirt and rust off of the stock frame where the ladder bar crossmember, support brace and secondary outrigger will attach (Photo 4 & 5).

NOTE: You may want to carefully remove the emergency brake cable tabs for later installation.

STEP 5

Measure the frame width at the rear crossmember and divide this number by two, to locate the centerline of the stock frame. Measure out 14" on each side of the centerline and mark the crossmember. Now install the mounting plates on the crossmember. These plates should hang 1/2" below the stock crossmember.

STEP 6

The rear of the S&W frame rail unit has to be trimmed to fit against the mounting plates. **Note: If you do not have a 2 door model sedan or hardtop DO NOT cut your frame as described in this step. You must use your axle centerline reference point to locate the frame!!!**

64 -67

Measure 15/16" from the bottom back edge of the frame rail. Draw a line from this point to the top back corner of the frame rail. This forms a 73 degree angle with the top edge. Cut the S&W frame rail along this line.

68- 72

Measure 3-1/2" from the back edge of the frame rail. Draw a line at this point that is square with the top edge of the frame rail. Cut the S&W frame rail along this line.

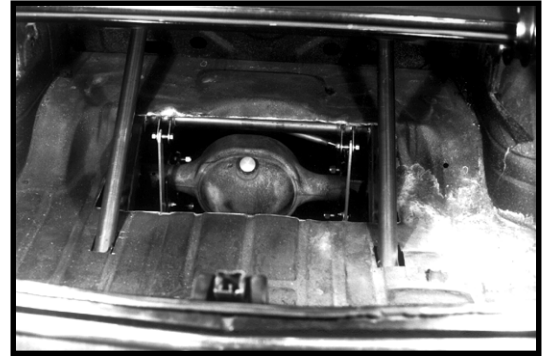

Photo 1

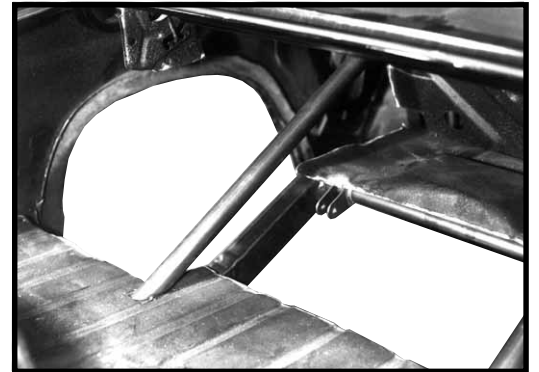

Photo 2

Photo 3



STEP 7

Now you are ready to put the S&W frame unit into your car. The bottom rear of the S&W frame should be flush with the bottom of the mounting plates on the rear crossmember (Photo 6). The ladder bar crossmember on the S&W frame fits between the stock frame, and should be flush with the top of the stock frame. Check all measurements, make sure both sides of the frame are even, and that all contact points are properly aligned. Now TACK weld all attachment points.

NOTE: S&W recommends using a MIG welder to do any welding. You should have a minimum of 32 tacks with the rails in place.

Put the frame support braces in the center of the pads on the front of the ladder bar crossmember and the other end against the stock frame. Push the brace up against the stock floor and tack weld in place.

STEP 8

When the frame is tacked in place, trial fit all suspension components - ladder bars, shocks, shock mounts & rear housing. *Now recheck your wheelbase and make sure the axle housing is centered in the wheel well opening.* If your wheelbase is correct, remove suspension & finish welding the frame in place.

STEP 9

You may now **CUT** away the the stock portion of the frame rails, they are no longer needed. From the center of the rear axle tube measure forward 20". Mark the stock frame at this point so it is square with the S&W frame.

Next place the rear frame brace between the S&W frame and the stock frame. The back of the brace should be 4" ahead of the frame mounting pad. The stock frame can be cut off any place ahead of the rear frame brace. Cut the front of the frame off. Use the caps that are provided to close off the end of the stock rails (Photo 7).

Step 10

At this time install your roll bar or cage as well as reinstall all suspension components. Please follow the instructions that come with each of these components during this phase of the assembly. To aid in the roll bar or cage installation, S&W has pre-welded mounting plates for the rear runners on your welded frame. (Photo 8)

Photo 8

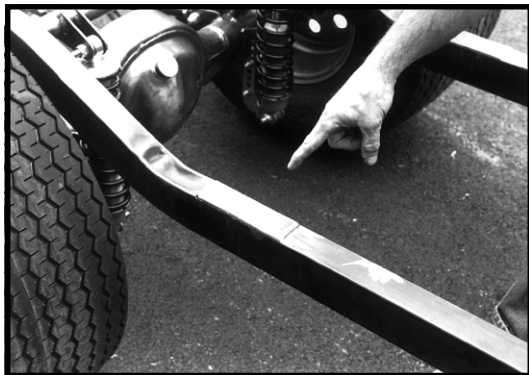

CAUTION!!!

The most important requirement for a successful installation of this, or any, frame package is that you take your time and use good common sense!!!

Check & recheck all measurements before cutting or welding. If at any time before or during the installation you have any questions - STOP - and call our tech line at 610-948-7303 and we will gladly explain in more detail any step in the installation.

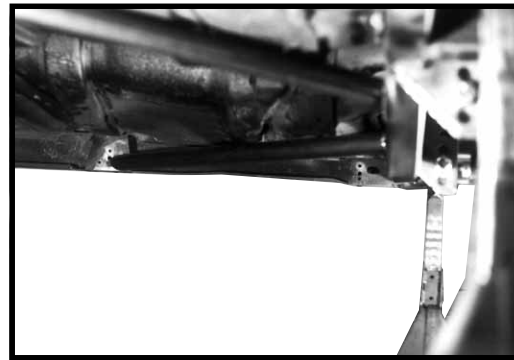

Photo 4

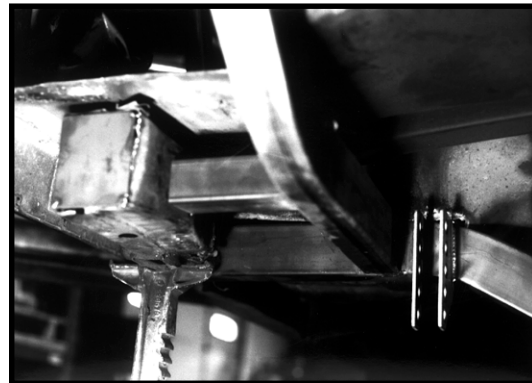

Photo 5



Photo 6

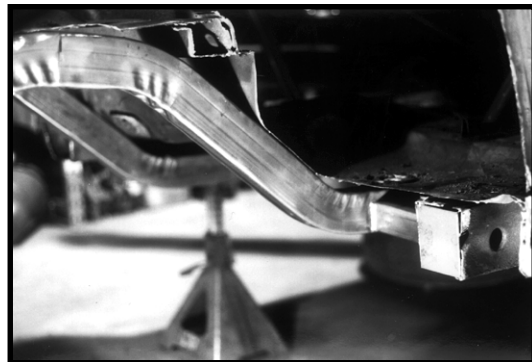

Photo 7

The S&W 64-72 Chevelle welded frame package is designed to use wheels and tires with the following dimensions:

Wheels: 14" or 15" wide with 4-" backspacing.

Tires - (Pro Street): 19.5" or 21.5" Mickey Thompson Tire.

Tires - (Drag Race): 14" x 32" or 15" x 33" Drag tire

The rear housing with axles should measure 44" axle flange to axle flange.

To mount the housing brackets refer to figure 1.

NOTE:

All measurements are based on using part # 45-1137 new style big Ford 3.150" bearing housing ends and a 9" Ford housing!! If it is your desire to use another style housing or housing end, please contact your S&W Race Cars salesperson for the correct housing width for your application

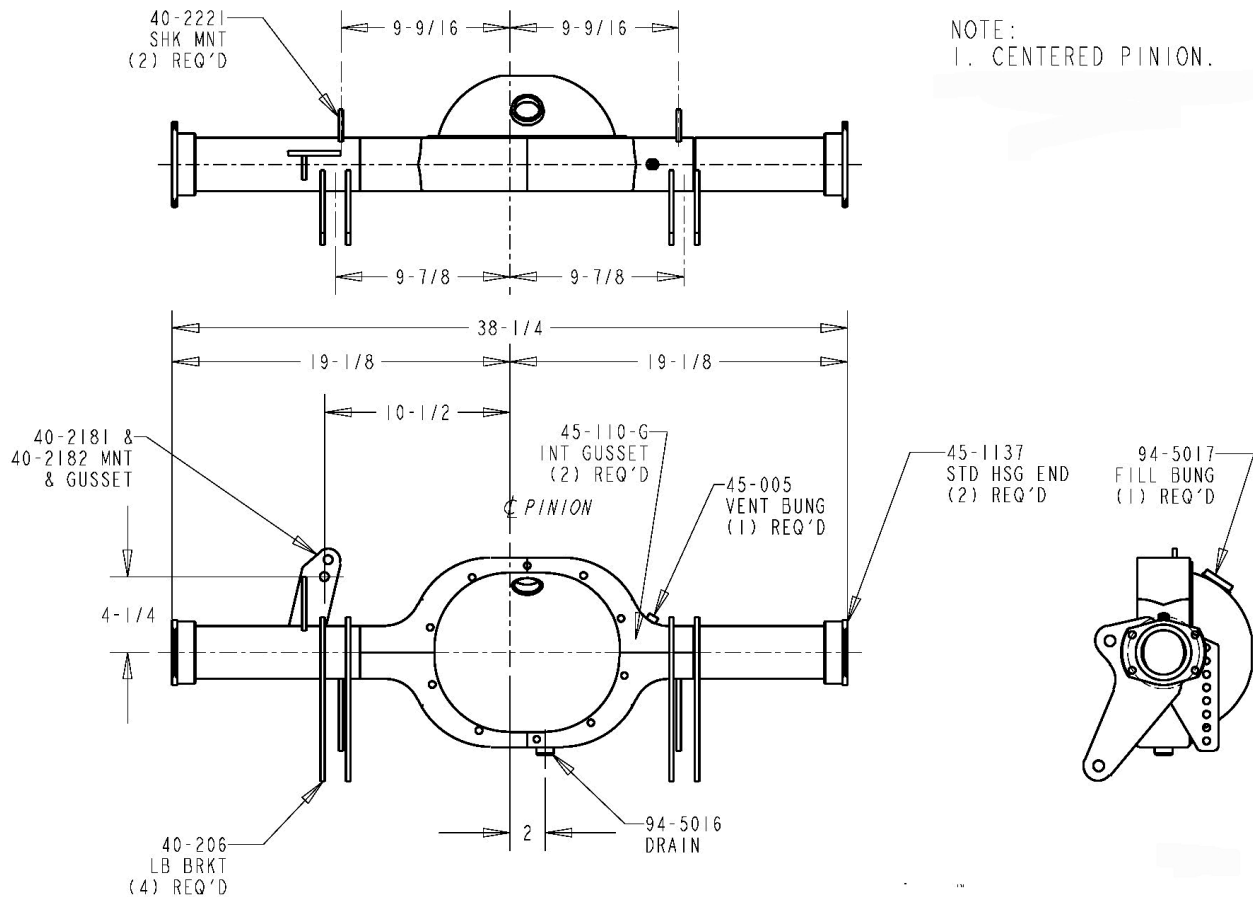

S&W Products Available to Complete Frame Installation

40-100	32" Ladder bars w/ Standard rod ends	40-222	Adjustable lower shock mounts
40-100T	32" Ladder bars w/ Teflon lined rod ends	50-051	Strange aluminum coil over shocks <i>springs sold separately</i>
40-101	32" Ladder bars w/ Chrome moly rod ends	50-019A	QA-1 steel coil over shocks <i>springs sold separately</i>
40-104	32" Double adjustable ladder bars with standard rod ends	95-390	38" Aluminum wheel tubs
40-104T	32" Double adjustable ladder bars with Teflon lined rod ends	95-392	40" Aluminum wheel tubs
40-105	32" Double adjustable ladder bars with Chrome moly rod ends	95-393	38" Steel wheel tubs
40-219	64-72 Chevelle welded panhard bar	95-394	40" Steel wheel tubs
40-403	Track locator bar (not for street use)	11-002	64-67 Chevelle 8 point roll bar
40-223-***	Pro/Series 2000 Shock & spring kit	11-003	68-72 Chevelle 8 point roll bar
	with adjustable lower mounts • Springs determined by application	11-502	64-67 Chevelle 10 point roll cage
		11-503	68-72 Chevelle 10 point roll cage
		13-350	Front subframe supports - converts 10 point cage to 12 point