

TOLIX STEEL DESIGN S.A.S.

PATIO LOUNGE SLATTED ARMCHAIR
[ed. 2024]

PARC D'ACTIVITÉS SAINT-ANDOCHE 18, BOULEVARD BERNARD GIBERSTEIN
71400 AUTUN FRANCE SALES@TOLIX.COM +33 (0)3 85 86 96 67
WWW.TOLIX.COM @TOLIXSTEELDESIGN

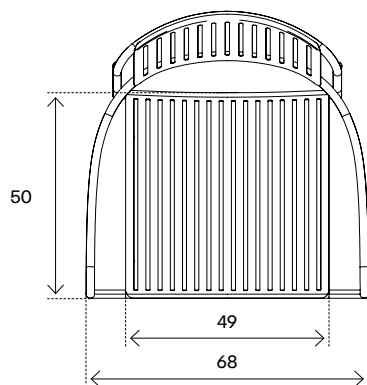

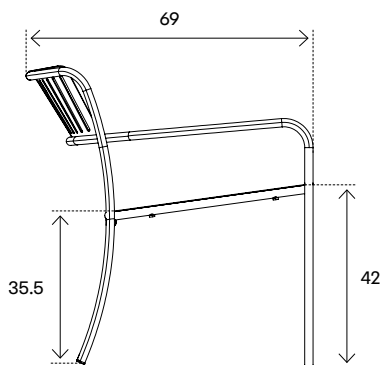
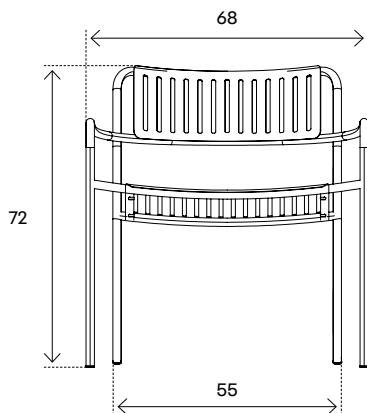

PATIO LOUNGE SLATTED ARMCHAIR

designer:	Pauline Deltour	creation:	2020
guarantee:	two years	fabrication:	handmade in Autun, France
dimensions:	W.68 ^[CM] D.69 ^[CM] H.72 ^[CM]	material:	stainless steel steel
seat:	W.49 ^[CM] D.50 ^[CM] H.42 ^[CM]	finition:	color galva
weight*:	6.5 ^[KG]	use:	outdoor
highlights:	stackable up to 4 units	assembly:	assembled

Pure White ^[RAL_9010]

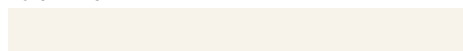

Grey Beige ^[RAL_1019]



Moss Green ^[RAL_6005]



Oyster White ^[RAL_1013]



Reed Green ^[RAL_6013]



Galva



*galva weight 7,8^[KG]