

# Installation Manual

Motorised Mirror Drop  
DT-MMDv2



## Table of Contents

PLEASE READ PRIOR TO INSTALLATION .....	3
Important Notes.....	3
SAFETY INFORMATION.....	4
Unpacking .....	5
Installation .....	6
Fitting the Frame.....	6
Option 1 - Timber Installation.....	6
Option 2 – Threaded Rod Installation.....	8
Fitting the Mirror Module.....	9
Fitting the Trim Ring.....	10
Electrical Operation – Testing` .....	11
Projector Installation .....	12
Mirror Setup.....	16
Primary mirror setup.....	16
Secondary mirror setup .....	16
Bottom Cover Installation.....	19
Volt Free Trigger Operation. ....	<b>Error! Bookmark not defined.</b>



## PLEASE READ PRIOR TO INSTALLATION

Before installation of this projection screen you should fully read these instructions to ensure you are aware of the full installation procedure. In addition to the screen and accessories and in order to carry out the installation you will need:

- Suitable screw fixing screws/fixings for fixing of the frame
- Spirit level
- Measuring tape

In the Installation accessories you will find:

- IEC Power cord of the relevant type for your location
- 5mm Allen key

It is recommended that at least 2 people install this mount. Due to the weight relevant Lifting equipment must always be used to support the mount and the weight of the projector during installation. **Fully read the manual prior to commencing installation.**

### Important Notes

The symbols below show important notes that must be read and understood at each stage of installation



= Warnings (Safety or Installation Quality)



= Information (Installation requirements or tips)

**From time to time we will release updated versions of manuals. To ensure that you always have the latest version always check against the relevant product on our website –**

**[www.displaytechnologies.co.uk](http://www.displaytechnologies.co.uk)**

Any support questions can be sent to our support team – [support@displaytechnologies.co.uk](mailto:support@displaytechnologies.co.uk)



## SAFETY INFORMATION

**WARNING:** Risk of Electrical shock. Only authorised installers should open electrical control boxes contained within or for the control of this product.

**WARNING:** Do not exceed the weight capacity stated for each product or component. Failure to do so can result in serious personal injury or damage to the equipment.

**WARNING:** It is the installer responsibility to ensure that any structure that product of component supplied is to be fixed to is of adequate structural strength prior to installation. Failure to do so can result in serious personal injury or damage to the equipment. It is recommended that the structure being fixed to is able to support a weight 5x the weight of the component plus and final equipment being mounted to the component.

### **WARNINGS:**

1. Read all technical instructions fully before installation and use. It is the installer's responsibility to ensure that all documentation is passed on the end user and read fully before operation.
2. Keep all documentation.
3. Heed all warnings.
4. Follow all technical specifications and instructions during installation.
5. Do not use near water unless the product has been specifically designed to do so.
6. Clean only with a dry cloth. Where the unit contains a mirror read and adhere to the Mirror Cleaning Guide
7. Do not defeat the purpose of the polarized or grounding type plug. A polarized plug has two blades, one wider than the other. A grounding type plug has two blades and a grounding prong. The wide blade or third prong are provided for your safety. If the provided plug does not fit your outlet, consult an electrician or contact the manufacturer.
8. Protect the power cord from being walked on or pinched, particularly at plugs, convenience receptacles, and the point where the exit from the apparatus.
9. Unplug the apparatus during lightning storms or when unused for long periods of time.
10. Only use attachments/accessories specified by the manufacturer.
11. Refer all servicing to qualified personnel. Servicing is required regularly on an annual basis, when the apparatus is damaged in any way, liquid has been spilled or objects have fallen into the apparatus, the apparatus has been exposed to rain or moisture, does not operate normally, or has been dropped.
12. To completely disconnect the apparatus from the AC mains, disconnect the power cord plug from the AC receptacle on the power control box.
13. To prevent overheating, do not cover the apparatus. Install in accordance with the instructions.
15. No naked flames such as lit candles should be placed on the unit.
16. Observe and follow the local regulations when disposing of batteries.
17. Do not expose the unit to dripping or splashing fluids.
18. Do not place objects filled with liquid, such as vases, on the unit.
19. Do not expose the batteries to excessive heat such as sunshine, fire or the like.
20. For all mounted apparatus, the apparatus should be installed on solid wood, bricks, concrete or solid wood columns and battens.
21. Always turn off power at source before putting on or taking off parts and cleaning.

22. Do not use outdoors unless marked for outdoor use.
23. Exceeding the weight capacity can result in serious personal injury or damage to equipment.

## Unpacking

Each mount is carefully packaged in a wooden crate in our factory to ensure that it reaches you in perfect condition. Where appropriate each section is wrapped in protective packaging or in a PVC sleeve to ensure it is protected and stays clean.

 Do not unpack each piece from its protective packaging until you are ready to install it. This will ensure that you do not damage any pieces accidentally during installation.

1. Remove the trim ring from the frame, slacken the 4 thumb screws and lift the trim ring straight up.
2. Remove the 4 M8 black bolts from the silver joining bar. DO NOT remove the two silver M6 bolts in the slot.
3. Slide the joining plate back towards the rear of the mount
4. Repeat for the joining bar on the other side of the projector

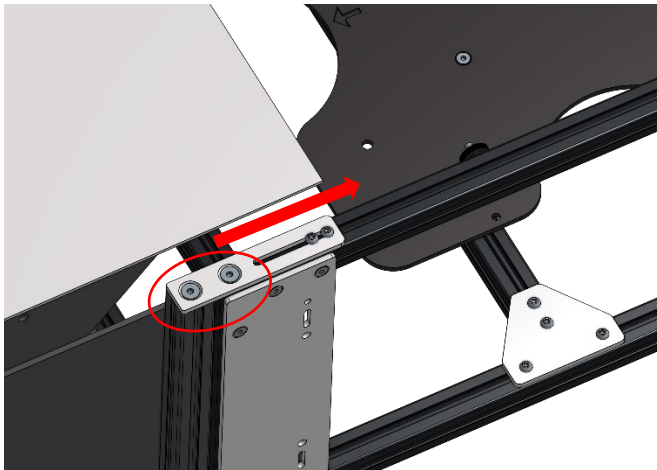

Figure 1 – Joining bar release

5. Lift the Mirror Module straight up to release it from the main frame.



Figure 2 – Mirror Module Removal

## Installation

### Fitting the Frame

There are two fixing methods for the frame, either into timber framework down either side of the MMD frame or suspended via threaded rods.

#### Option 1 - Timber Installation

1. Lift the frame into position in the space created between the timber frame work. (Details of cut-out sizes can be found on the online CAD drawings for the MMDv2)
2. **The base of the frame should sit 36mm [1.4"] above the finish ceiling level.** Measure this height and then fix the frame into the wood frame using the fixing holes in the 4 side corner plates.



Fixing size and number should be used to hold the relevant combined weight of the mount, projector and lens. The installer is responsible for ensuring adequate number and sized fixings are used.

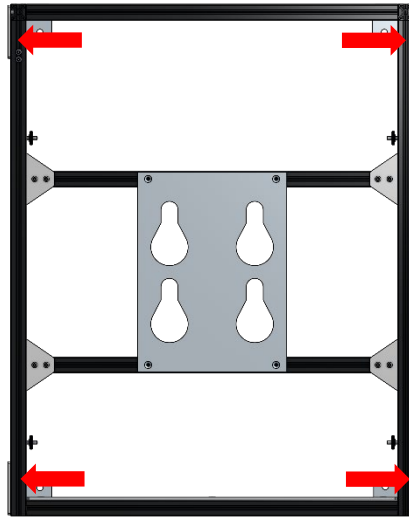

*Figure 3 - Projector Frame Fixing Locations*

3. Use spirit level to check the frame is level and double check the distance from the frame base to the finished ceiling it 36mm [1.4"]. If required adjust as necessary.

## Option 2 – Threaded Rod Installation

1. Lift the frame into position in the space created in the ceiling. (Details of cut-out sizes can be found on the online CAD drawings for the MMDv2). Locate the frame onto the threaded rods installed to fix the frame to.
2. The base of the frame should sit 36mm [1.4"] above the finish ceiling level. Measure this height and then fix the frame onto the metal rods.

 Fixing size and number should be used to hold the relevant combined weight of the mount, projector and lens. The installer is responsible for ensuring adequate number and sized fixings are used.

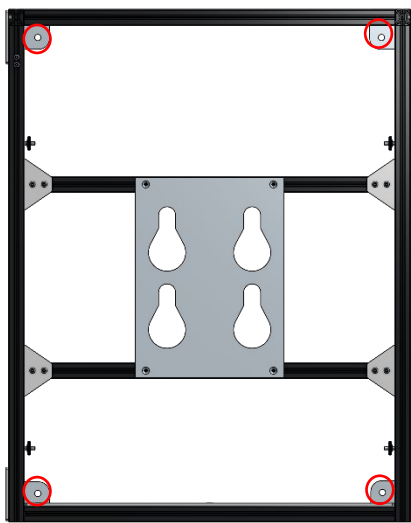

Figure 4 – Threaded Rod Hanging Points

3. Use spirit level to check the frame is level and double check the distance from the frame base to the finished ceiling it 36mm [1.4"]. If required adjust as necessary.



## Fitting the Mirror Module

The Mirror Module is fitted the reverse of the method to remove it from the frame on unpacking.

1. Lift the mirror module up into position
2. While doing this feed the power cable and any required control cable down through the access hole in the top of the Mirror Module.
3. Align the top white plastic sliders on the frame to the groove in the aluminium profile on the upright of the mirror module.
4. Slide the mirror module right up ensuring that the second white plastic slider engages into the groove as you raise the module up.

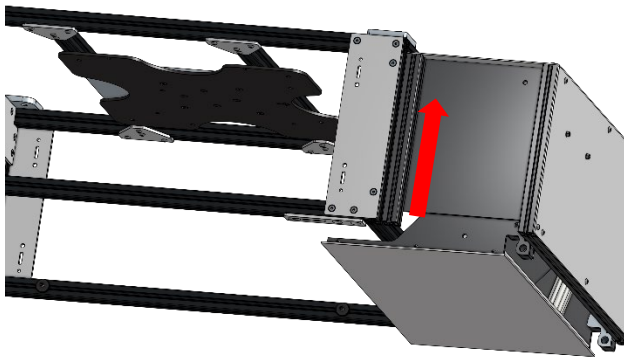

Figure 5 – Mirror Module Location

5. Slide the joining plate back towards the front of the mount
6. Bolt into position using two of the M8 black bolts through the joining bar; one into the frame of the mount and one into the frame of the mirror module
7. Repeat for the joining bar on the other side of the projector

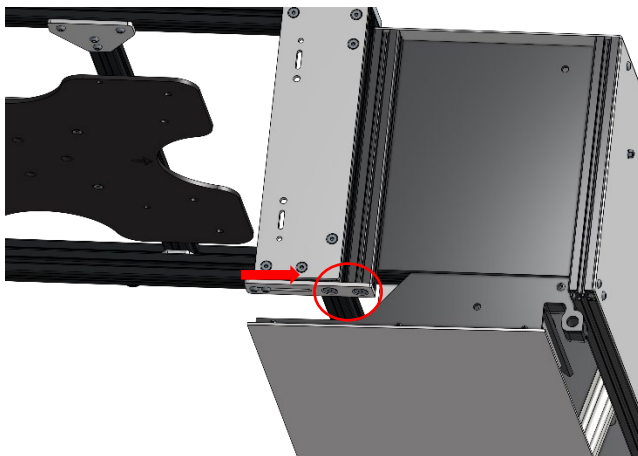

Figure 6 – Mirror Module Locking Plates

## Fitting the Trim Ring

1. Slacken the 4 thumb nuts so that they are almost at the end of the thread on the stud.
2. Lift the trim ring up into position locating the slots on the trim ring onto the 4 studs.
3. Ensure that the underside of the trim ring is sat flush with the ceiling finish all around.
4. Tighten the 4 thumb nuts to lock the trim ring into place.

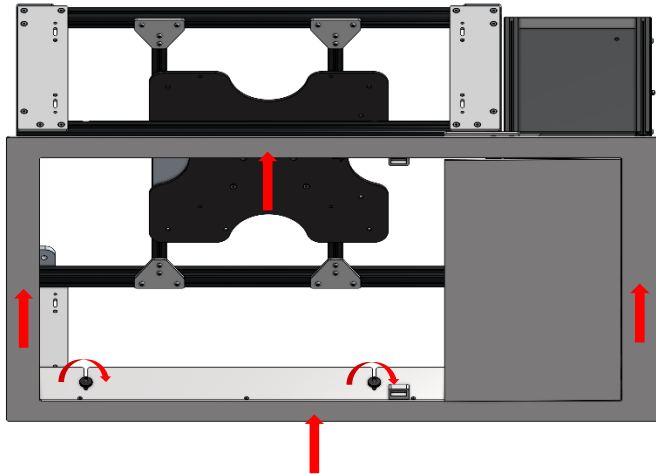

Figure 7 – Trim Ring Installation

## Electrical Operation – Testing`



It is important to now test the operation of the mirror.

1. Plug in the power cord previously fed through the access hole in the top of the mirror module to the power supply.
2. Wait 30 seconds.
3. Press the ▼ button on the keypad. The mirror flap will move down while this is held. Release the button to stop.
4. Press the ▲ button on the keypad. The mirror flap will move up while this is held. Release the button to stop.



if the unit does not operate it may require 'Homeing' following shipping and installation. To do this simply hold down the,



button **for >5 seconds**. Dependant on the location of the mirror you may see the mirror moving towards the fully closed position before stopping. Following this you will then be able to operate the mirror mechanism as above.

## Projector Installation



It is normally easiest to install the projector with the mirror in the 'down' position as this gives easier access into the frame.



Installation of the projector will require a minimum of two people and a lifting aid is recommended.

1. Remove the thumb locking bolt securing the projector locking plate to the side of the frame.
2. Slide the projector locking plate 75mm (3") across to the middle of the frame.
3. The projector plate is now free to slide back and off the keyhole mounts
4. Bolt the Projector Plate to the projector using the correct mounting holes along with the correct bolts provided for the specific projector.
5. Lift the Projector up into the frame locating the lugs on the projector plate into the keyholes on the frame.
6. Slide the projector fully forward on the keyholes ensuring it is fully located.
7. Slide the projector locking place back across until it hits the side of the frame.
8. Replace the thumb locking bolt into the projector locking plate, fixing it to the side of the frame.



The projector locking plate must be fully closed and locked back into position.

9. Dependant on the model of the projector you may need to slide the projector forward or backward so that the lens is approximately 50mm [2"] from the primary mirror. To do this slacken (don't remove) the 8 bolts holding the projector mount onto the MMD frame. Slide the projector to the desired location, then retighten the bolts.

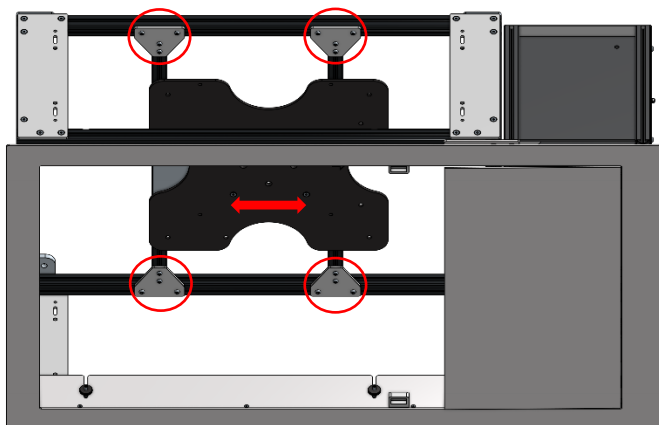

Figure 8 – Projector location adjustment

## DT-Actuator-Commander Software



This software is required for the manual control and setting of the MMDv2. Please install this software and follow this process for initial operation and setting the stop positions of the Secondary mirror.

### Installation

Install the software following the on-screen prompts.

### Connection

Connection to the Actuator Commander Control box should be done via USB.

1. Run the Actuator Commander software
2. Connect to the commander by selecting the comm port you have the commander connected on from the drop-down list. Then press the connect button.

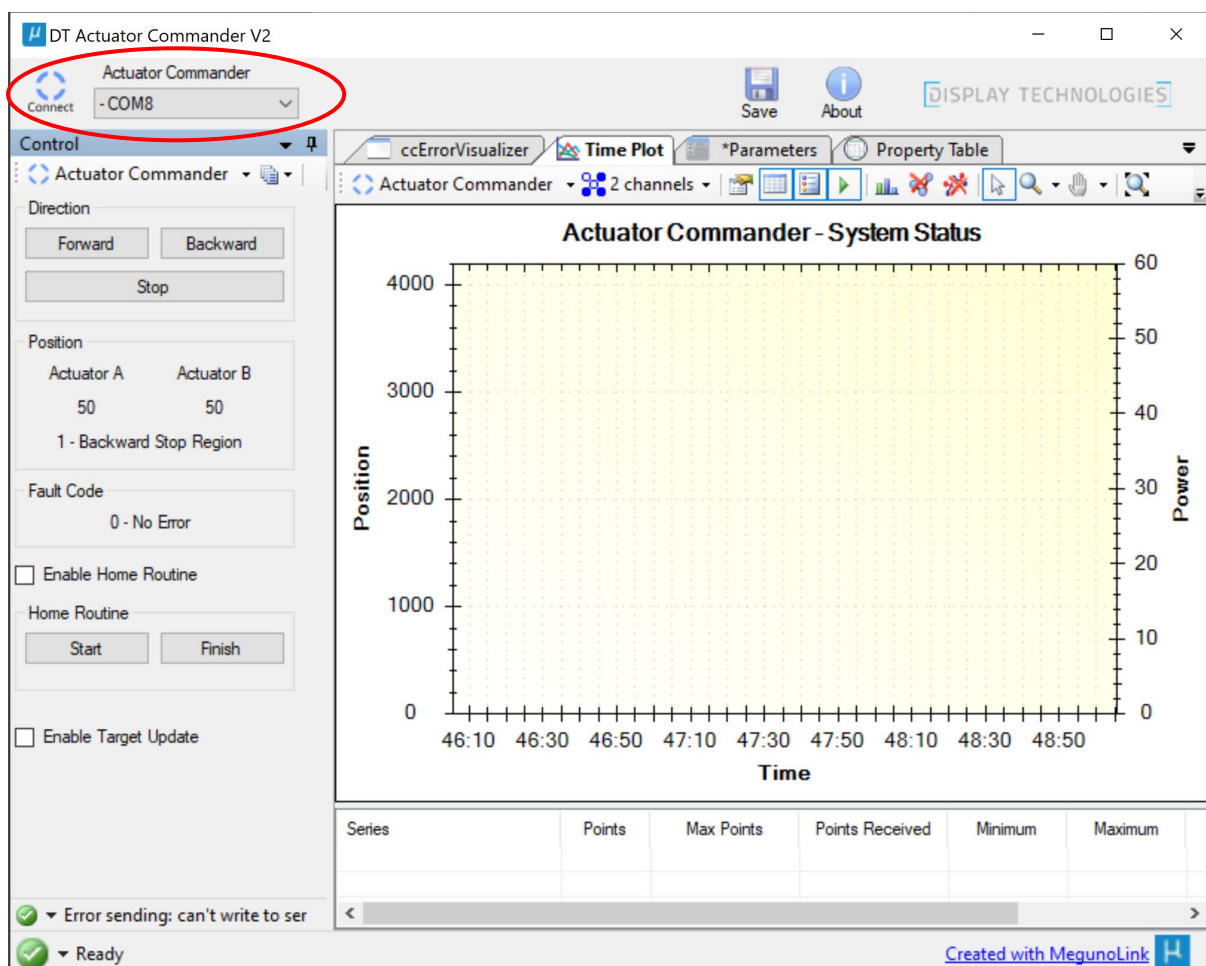

3. Control of the Actuators can now be done via the control button. (Note care should be taken during this as the stop positions of the actuators are not set for your product yet so only move a short distance to check operation.)

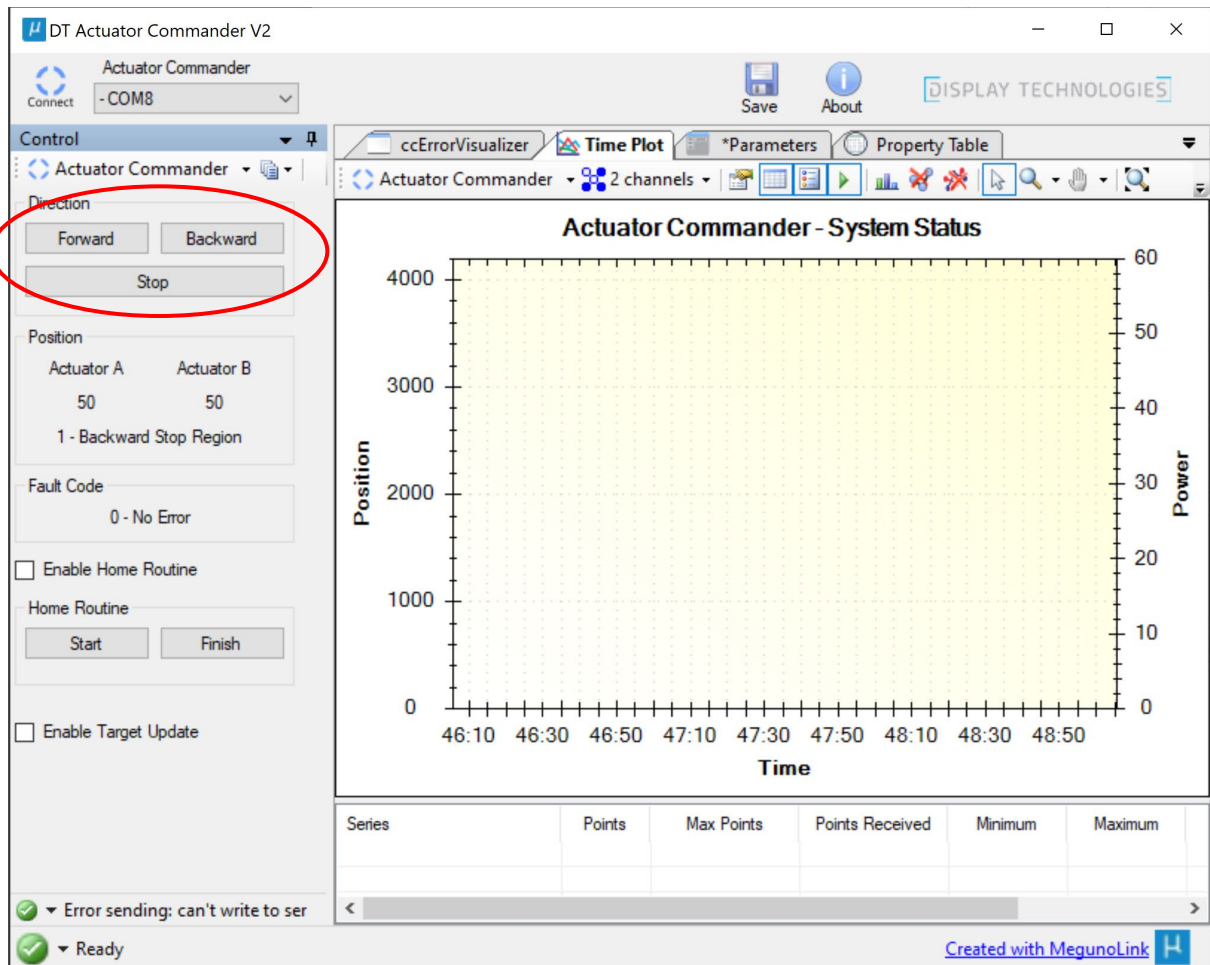

4. If the actuator does not respond to the commands, you will need to initiate a home routine. Check the 'Enable Home Routine' box, next press the 'Start'. **Note the actuators will now close to their full extent. Ensure that you do not obstruct any part of the device during this operation.**
5. Wait for 5-10 seconds after homing has finished before testing operation again.

## Setting Stops

Stops are set using the Actuator Commander Software.

1. Ensure that the software is open connected via USB and the device is connected in the software.
2. Select the 'Parameters' Tab

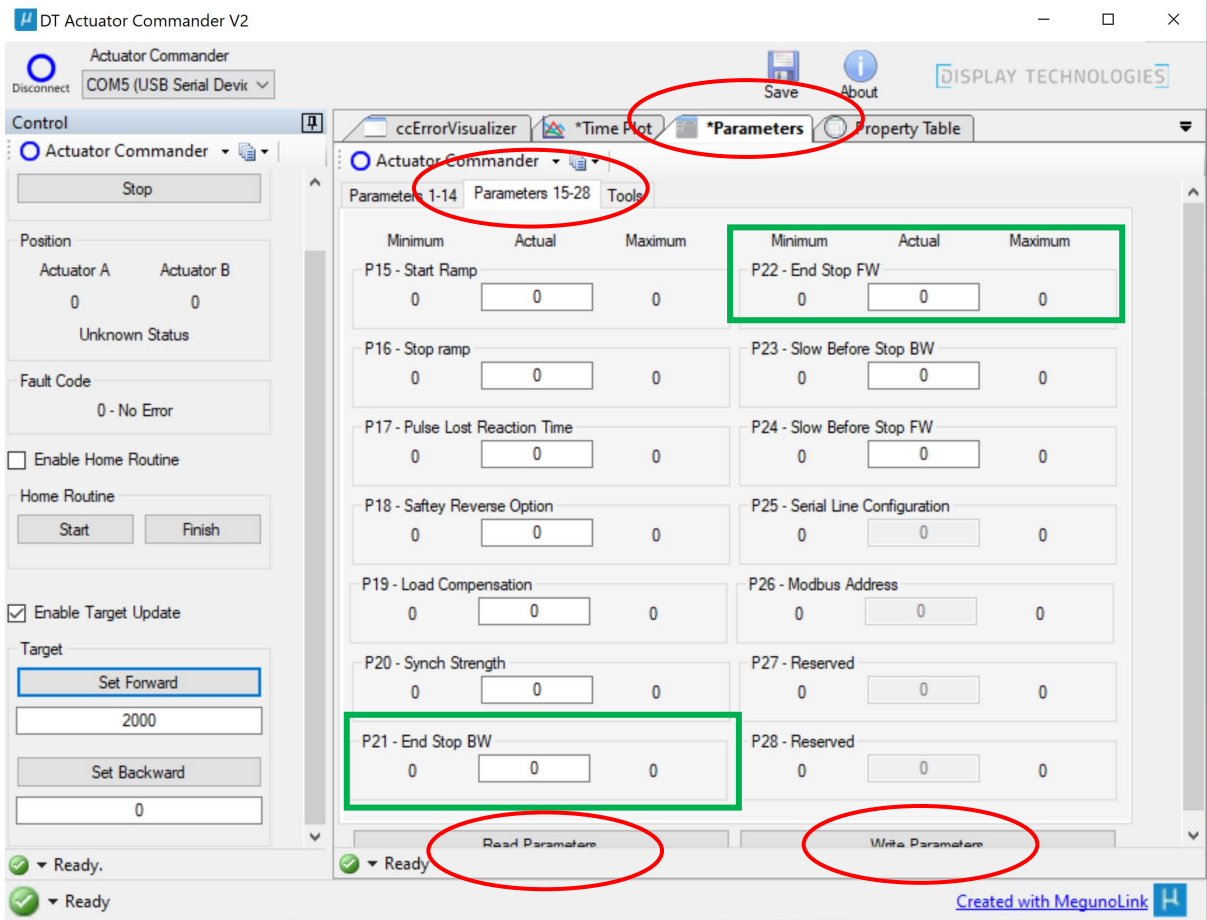

3. Scroll down and press the Read Parameters
4. You will now see numbers in the P21-End Stop BW and P22-End Stop FW.
5. To change the position of the close (actuator in) increase or decrease the P21-End Stop BW figure. Then press the Write Parameters button to commit the changes.
6. To change the position of the Open (actuator Out) increase or decrease the P22-End Stop FW figure. Then press the Write Parameters button to commit the changes.
7. Test operation and adjust as necessary
8. Do not change any other parameters unless specifically told to do so by Display Technologies Ltd Technical Support

## Mirror Setup

Both the primary and secondary mirrors will both need to be set up to get the correct light path to make the image from the projector fall correctly on the screen. We recommend starting the setup with the primary mirror



It is normally easiest to do the setup with the lens 'centred'. Dependant on the projector this may be a manual function or called 'Lens Calibration' or 'Lens Centre'. Next you will need to use the projector offset to shift the image down as far as possible (This will have the effect of shifting the image up the primary mirror).

### Primary mirror setup

To gain access to the primary mirror you will need to open the drop-down flap on the bottom of the MMD.

1. Power up the control box by plugging in the control box to the power supply and applying power.
2. Connect the MMD control box via USB to a computer with the DT-Actuator Commander software installed (see above section)
3. Press the 'Forward' button on the Actuator Commander Software. The mirror flap will move down while this is held. Release the button to stop.
4. Manually adjust the primary mirror so that the image from the projector sits centrally on the mirror with the mirror roughly at a 45 degree angle.
5. Lock the mirror into place.
6. Tilt the primary mirror so that the light path hitting the secondary mirror hits the secondary mirror towards to the top of the secondary mirror – (nearest the hinge point)

### Secondary mirror setup

The secondary mirror setup will require the screen to be installed and set to its correct position. The only adjustment on the secondary mirror is the angle.

#### *Forward Limit Position (Open Position)*



**By default, the MMD will be set to its fully open position. It's likely to ensure the mirror flap will need to be more closed in operation. Only decrease this figure from that set in the factory default. Increasing it can cause damage to the MMD.**

1. Follow the 'Setting steps' section of the Actuator Commander instructions above to set the required 'Forward Limit' Open Position of the mirror.
2. Use the Forward and Backward buttons in the software to test the newly saved limit position
3. The light path on the screen should sit in the middle of the screen top to bottom when the correct limit position is reached.



You will have to repeat this process several times to get the exact desired position.

### *Backward Limit Position (close Position)*



**By default, the MMD will be set to its fully closed position. It's likely to ensure the mirror flap sits flush with the ceiling you will need to increase the close parameter.**

1. Follow the 'Setting stops' section of the Actuator Commander instructions above to set the required 'Reverse Limit' Open Position of the mirror.
2. Use the Forward and Backward buttons in the software to test the newly saved limit position
3. The light path on the screen should sit in the middle of the screen top to bottom when the correct limit position is reached.



**Note that it normally takes several adjustments of both the primary and secondary mirror and the projector in tandem to get the complete light path set up. After the first round of setting you will likely notice keystone on the image which is usually adjusted by returning to the primary mirror and correcting its angle slightly. Once the image is square you may also need to adjust the vertical lens shift on the projector to align the image on the screen without moving the mirrors further.**

## Bottom Cover Installation

The bottom cover is simply magnetic.

1. Lift the back of the cover up into the frame so that the lugs engage up and over the frame.
2. Raise the front edge of the cover up to meet the magnets.
3. The cover can be slid around slightly to ensure an even and constant gap around it and the trim



**Ensure that there is a gap between the cover and the secondary mirror flap and that it does not catch in operation.**

## Communication Settings

Cable - Straight through DB9 - **Connection on pins 2,3,5 Only**

Baud Rate - **19200**

Data Bits - **8**

Parity - **N**

Stop Bits – **1**

## Control Protocol – RS232

Command	Action
!help	Returns all available commands
!forward	Moves the actuators in
!backward	Moves the actuators out

**All commands must be terminated with a Carriage Return**

Please note that all settings and troubleshooting should be performed using the DT Actuator Commander Windows Application connected via USB.