

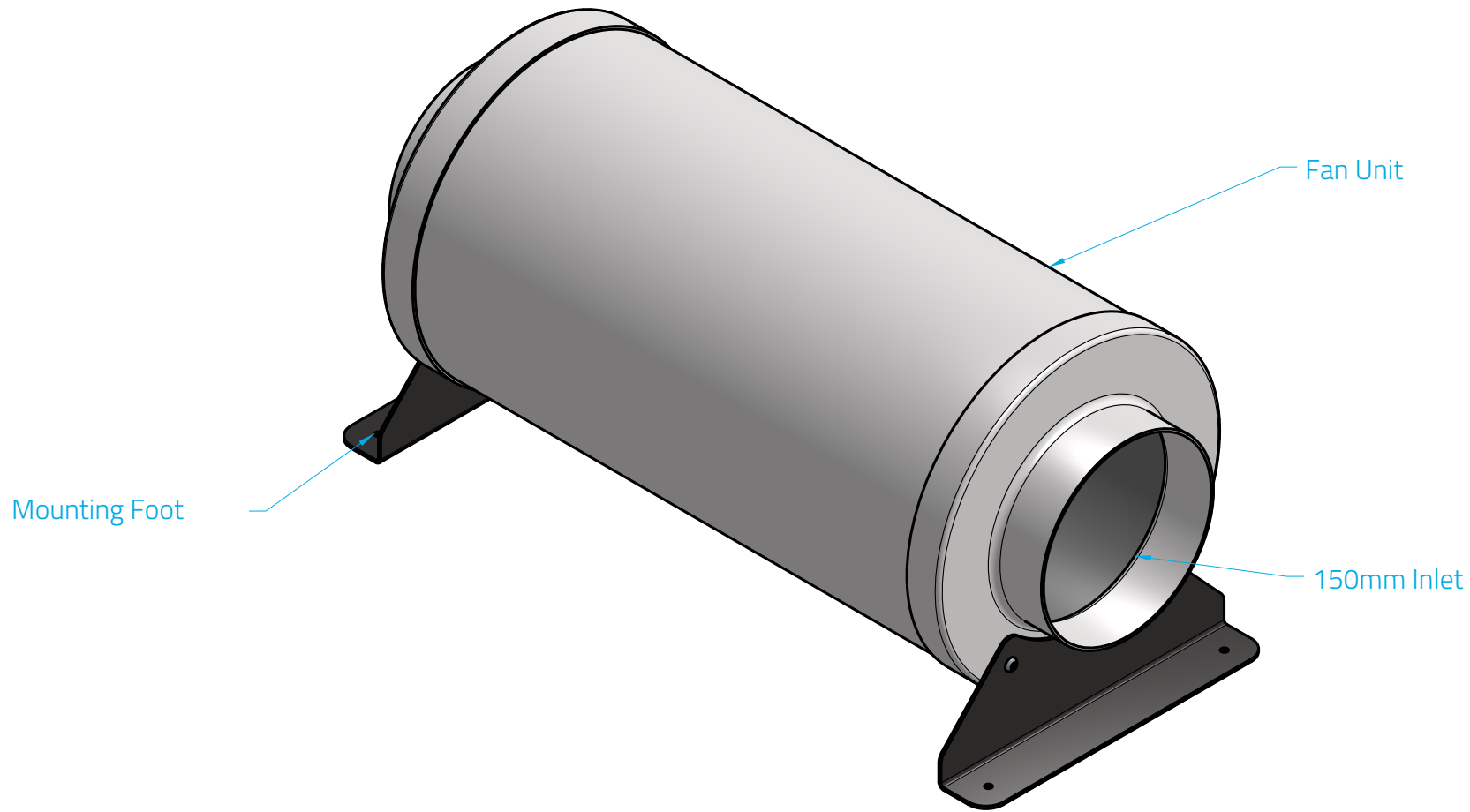

# MISTRAL-INLINE-150



	NAME	SIGNATURE	DATE	TITLE		
DRAWN	SIMON RIDLEY	SR	2020-01-12	DT-MISTRAL-INLINE-150 AIR HANDLING UNIT 150MM [6"]		
APPROVED						
UNLESS OTHERWISE SPECIFIED, DIMENSIONS ARE IN MILLIMETERS				SIZE	DWG NO.	REV.
				A4	MISTRAL-INLINE-150	/1 1.0
				SCALE	WEIGHT	SHEET
				1:4	5.2kg	1 of 3

SIDE

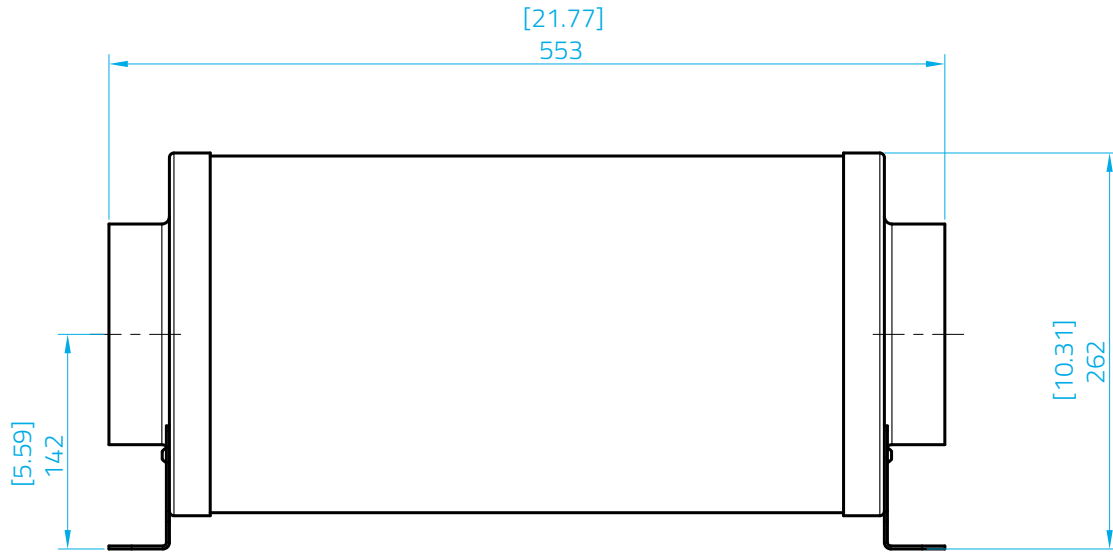

END

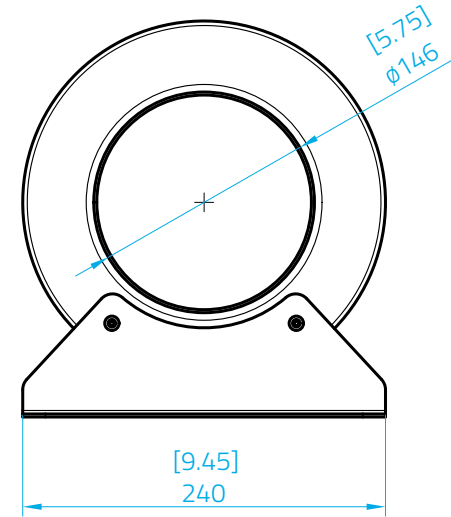

TOP

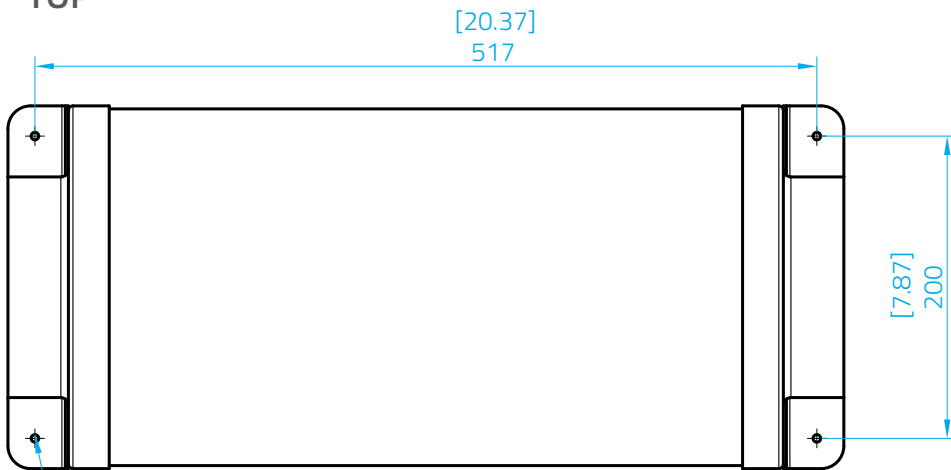

Mounting Hole

## SPECIFICATION

Airflow	594 M <sup>3</sup> /h [350 CFM]
Inlet Size	150mm [6"]
Outlet Size	150mm [6"]
Power	230v AC / 120V AC (model specific)
Power Consumption	40W
	IEC Cable supplied. Mains power outlet required.
Noise Level	50 dBA
Nett Weight	5.2kg [11.46lbs]
Control	Fan speed Control via DT-Commander. (Proprietary link cable supplied)

## NOTES

Supplied with:

- 2 x 3m 150mm acoustic flexible duct
- 2 x 150mm Hose Clips
- IEC Power Cable
- 2 x 3m 150mm acoustic flexible duct