



NOTES:

- ALL DIMENSIONS ARE IN 'MM' UNLESS SPECIFIED IN "[x]".
- ANY HAZARD SYMBOLS ARE TO BE READ IN CONJUNCTION WITH ANY RISK ASSESSMENT IF NUMBERED.
- THIS DRAWING IS PROPERTY OF DISPLAY TECHNOLOGIES LTD & IS STRICTLY CONFIDENTIAL. THE DRAWING SPECIFICATION & ITS CONTENTS MUST NOT BE DISCLOSED TO ANY THIRD PARTY WITHOUT PRIOR CONSENT.
- DRAWING SCALE IS ANNOTATED ON EVERY VIEW. IF IN DOUBT - ASK THE DESIGNER.
- DISPLAY TECHNOLOGIES RESERVE THE RIGHT TO MAKE DESIGN ALTERNATIONS THROUGHOUT CONTINUOUS PRODUCT DEVELOPMENT - IS IT THE CLIENTS RESPONSIBILITY TO ENSURE THEY REQUEST THE LATEST DESIGN REVISION.

SYMBOLS:

- PROVIDES A REFERENCE NUMBER FOR ADDITIONAL NOTATION.
- HIGHLIGHTS SPECIFIC MANUFACTURING INFORMATION.
- HIGHLIGHTS A HAZARD & OR A RESIDUAL RISK ASSOCIATED WITH THE DESIGN RISK ASSESSMENT.

REV	DESCRIPTION	DATE	INITIALS
0	ORIGINAL ISSUE.	12.12.23	SR

DESIGNED	CHECKED	APPROVED
S. Ridley	S. Ridley	S. Ridley
12.12.23	12.12.23	12.12.23

DRAWING STATUS

CLIENT ISSUE

TITLE

GENERAL OVERVIEW

PART NUMBER

[DT-MMD-ST]

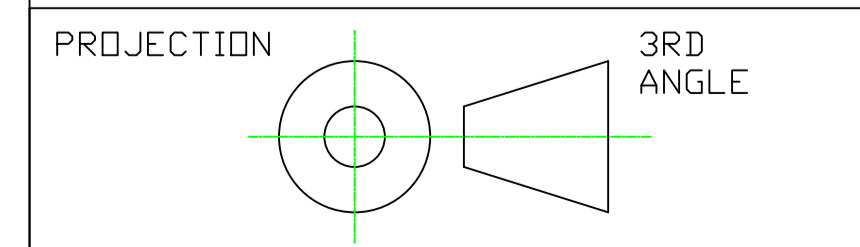

DRAWING No. DR-01	REV No. 0
----------------------	--------------

KNOB ON END OF BEAM TO PROVIDE ROTATIONAL ADJUSTMENT IF NECESSARY.

2No. STEEL RODS THAT RUN WIDTH OF FRAME TO SUPPORT HANGAR SYSTEM AS INDICATED.

CROSS PLATE (1 OF 2) PROVIDES SURFACE FOR PROJECTOR FEET TO FIX TO. BOTH PLATES HAVE LATERAL ADJUSTABILITY.

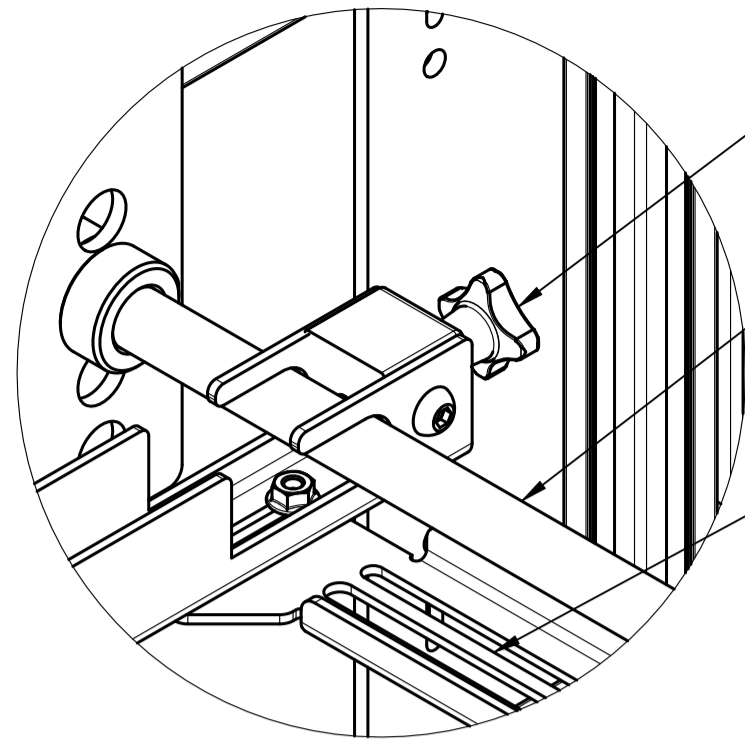

DETAIL (A)
DO NOT SCALE.

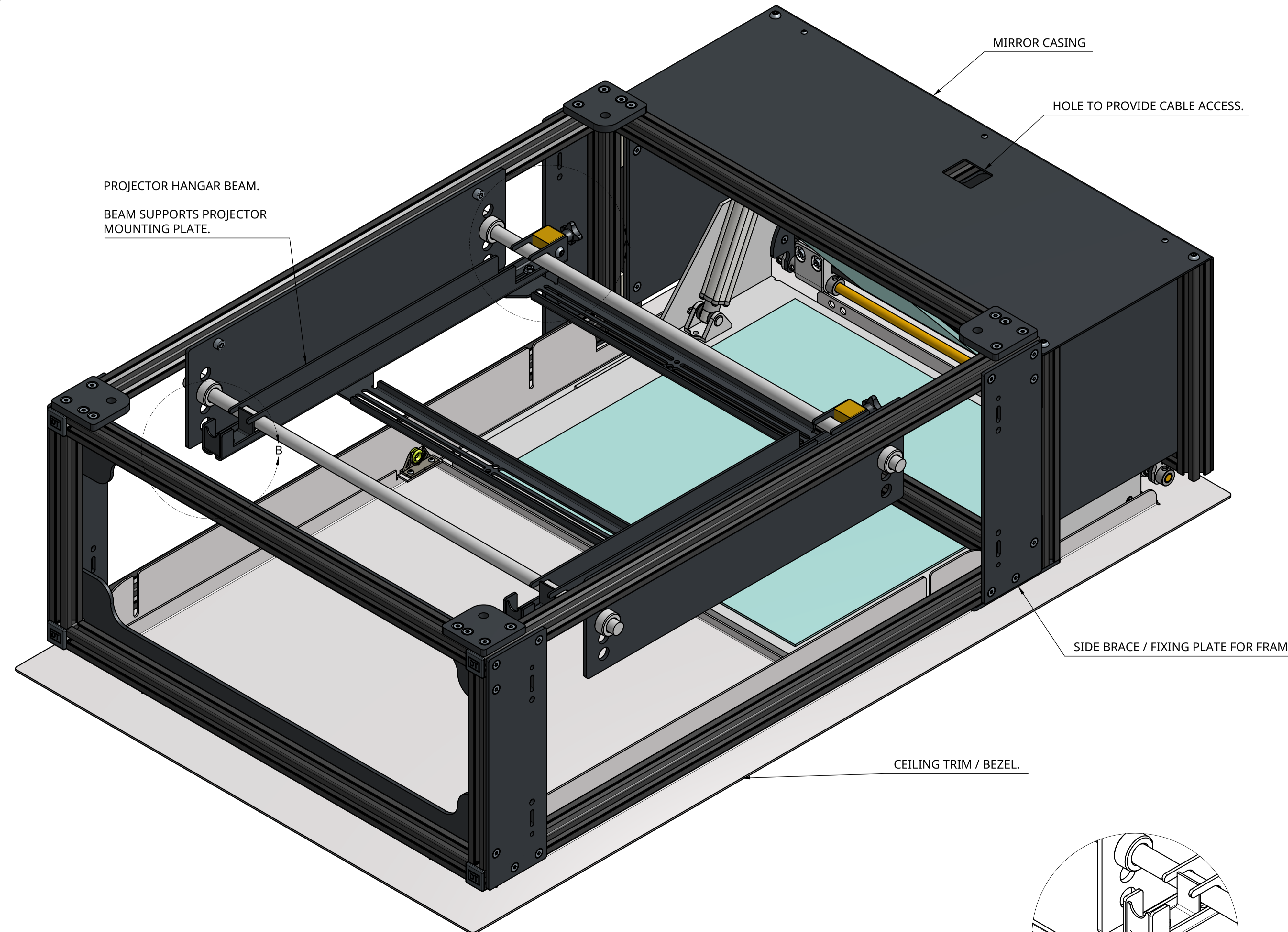

PROJECTOR HANGAR BEAM.
BEAM SUPPORTS PROJECTOR MOUNTING PLATE.

MIRROR CASING

HOLE TO PROVIDE CABLE ACCESS.

SIDE BRACE / FIXING PLATE FOR FRAME.

CEILING TRIM / BEZEL.

ISOMETRIC VIEW
DO NOT SCALE.

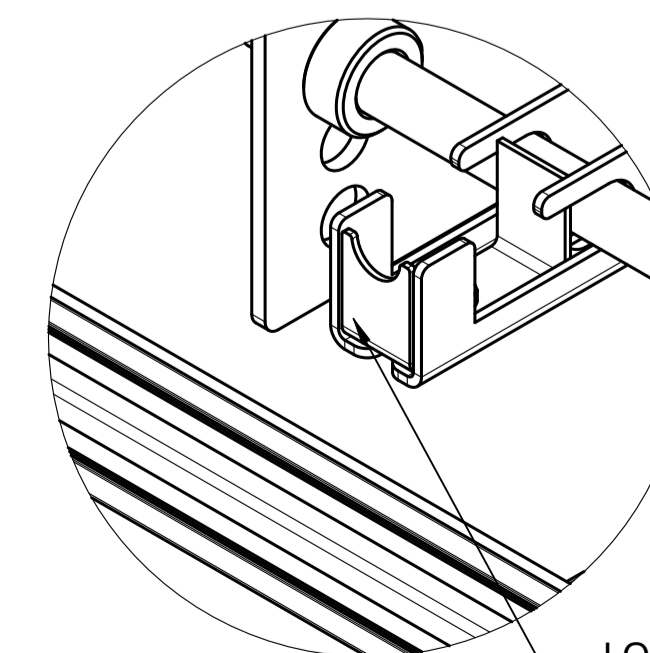

DETAIL (B)
DO NOT SCALE.

LOCKING PLATES ARE PROVIDED TO PREVENT BEAMS SLIDING OFF OF SUPPORTING STEEL RODS.



NOTES:

- SEE DETAILS (C) & (D) FOR INSTALLATION / FIXING INFORMATION.
- CEILING TRIM COMES WITH VERTICAL ADJUSTABILITY OF ±7mm ON EACH END OF UNIT FOR CHANGES IN EXISTING STRUCTURE.



IT IS THE CLIENTS RESPONSIBILITY TO ENSURE **SUITABLE** FIXINGS ARE USED, & THAT FIXINGS ARE FIXED WHERE MOST APPROPRIATE.

CLIENT TO ENSURE FIXINGS ARE ABLE TO WITHSTAND COMBINED LOAD OF MMD UNIT + PROJECTOR, PROJECTOR LENS & ALL ANCILLIARIES.



THE CLIENT HAS THE ABILITY TO MOUNT THIS PRODUCT USING ALL MOUNTING POINTS DETAILED IN DETAILS (C) & (D).



NOTES:

- ALL DIMENSIONS ARE IN 'MM' UNLESS SPECIFIED IN "[x]".
- ANY HAZARD SYMBOLS ARE TO BE READ IN CONJUNCTION WITH ANY RISK ASSESSMENT IF NUMBERED.
- THIS DRAWING IS PROPERTY OF DISPLAY TECHNOLOGIES LTD & IS STRICTLY CONFIDENTIAL. THE DRAWING SPECIFICATION & ITS CONTENTS MUST NOT BE DISCLOSED TO ANY THIRD PARTY WITHOUT PRIOR CONSENT.
- DRAWING SCALE IS ANNOTATED ON EVERY VIEW. IF IN DOUBT - ASK THE DESIGNER.
- DISPLAY TECHNOLOGIES RESERVE THE RIGHT TO MAKE DESIGN ALTERNATIONS THROUGHOUT CONTINUOUS PRODUCT DEVELOPMENT - IS IT THE CLIENTS RESPONSIBILITY TO ENSURE THEY REQUEST THE LATEST DESIGN REVISION.

SYMBOLS:

- PROVIDES A REFERENCE NUMBER FOR ADDITIONAL NOTATION.
- HIGHLIGHTS SPECIFIC MANUFACTURING INFORMATION.
- HIGHLIGHTS A HAZARD & OR A RESIDUAL RISK ASSOCIATED WITH THE DESIGN RISK ASSESSMENT.

REV	DESCRIPTION	DATE	INITIALS
0	ORIGINAL ISSUE.	12.12.23	SR

DESIGNED	CHECKED	APPROVED
S. Ridley	S. Ridley	S. Ridley
12.12.23	12.12.23	12.12.23

DRAWING STATUS

CLIENT ISSUE

TITLE

GENERAL OVERVIEW

PART NUMBER

[DT-MMD-ST]

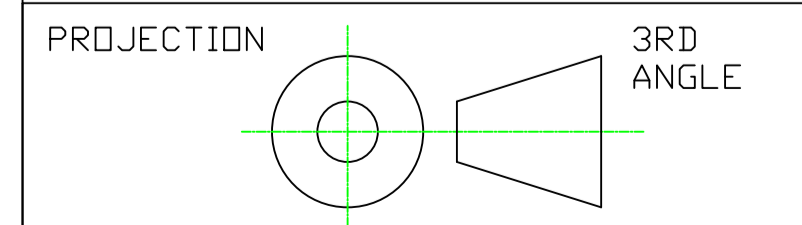

DRAWING No. DR-02	REV No. 0
----------------------	--------------

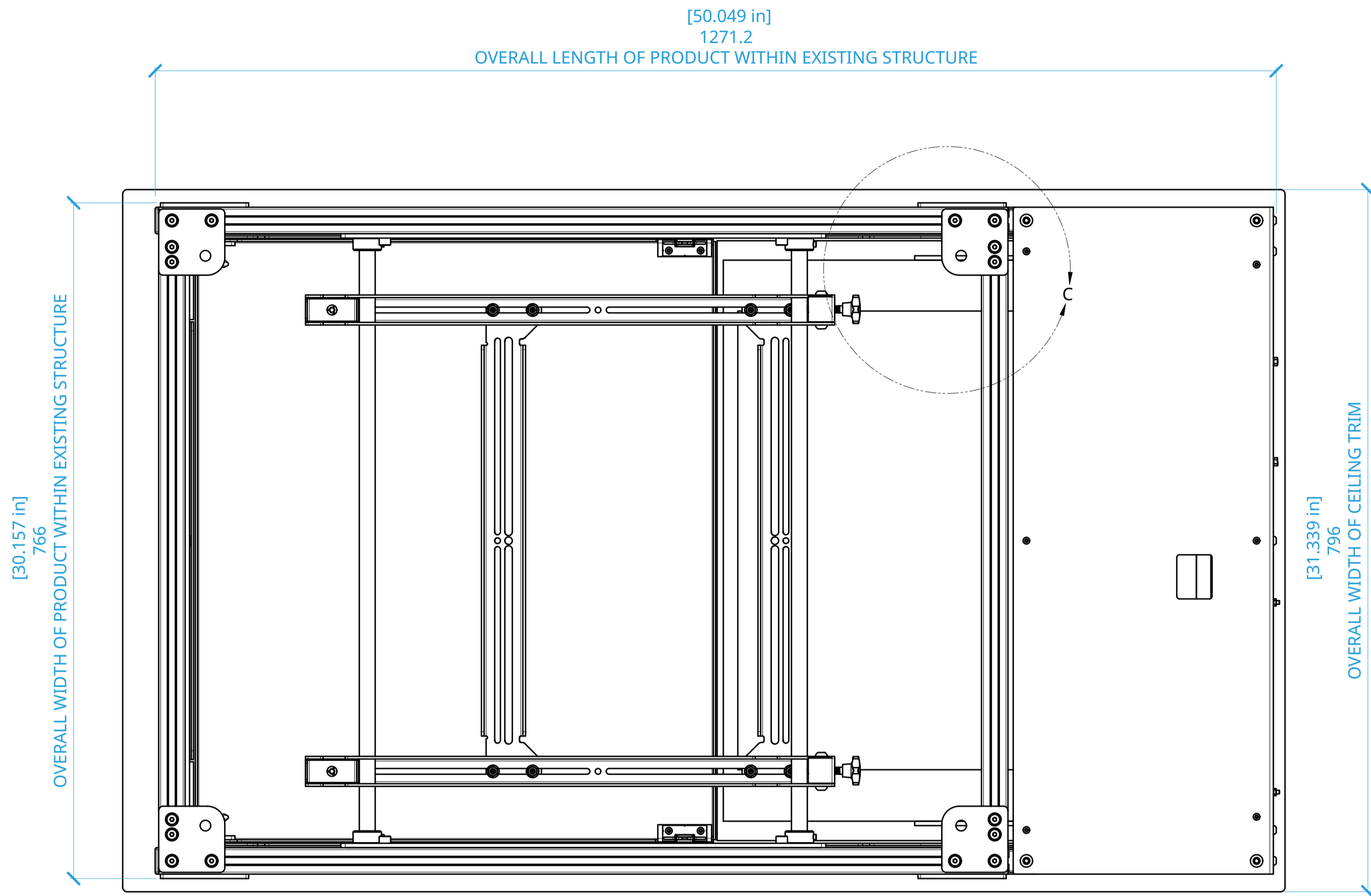

PLAN VIEW
SCALE 1:4 @ A1

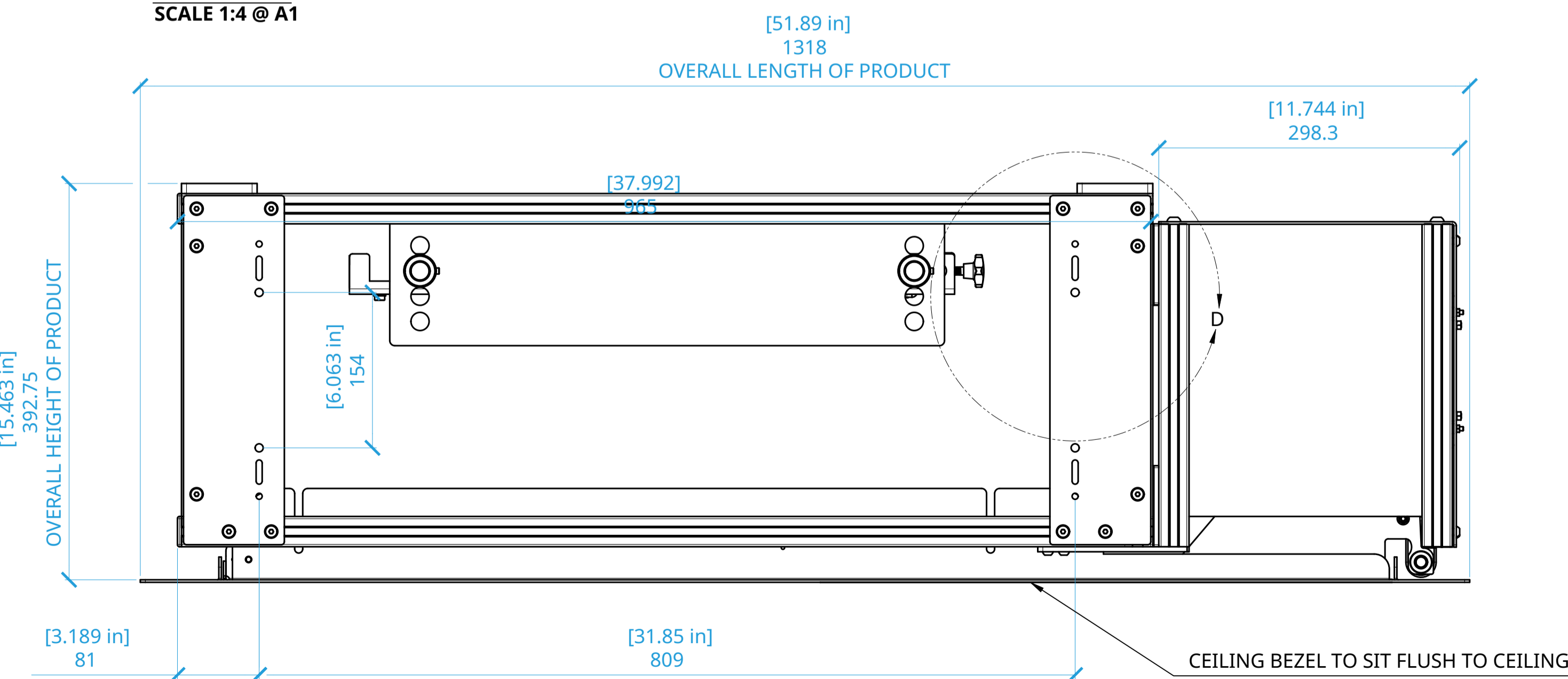

SIDE ELEVATION
SCALE 1:4 @ A1

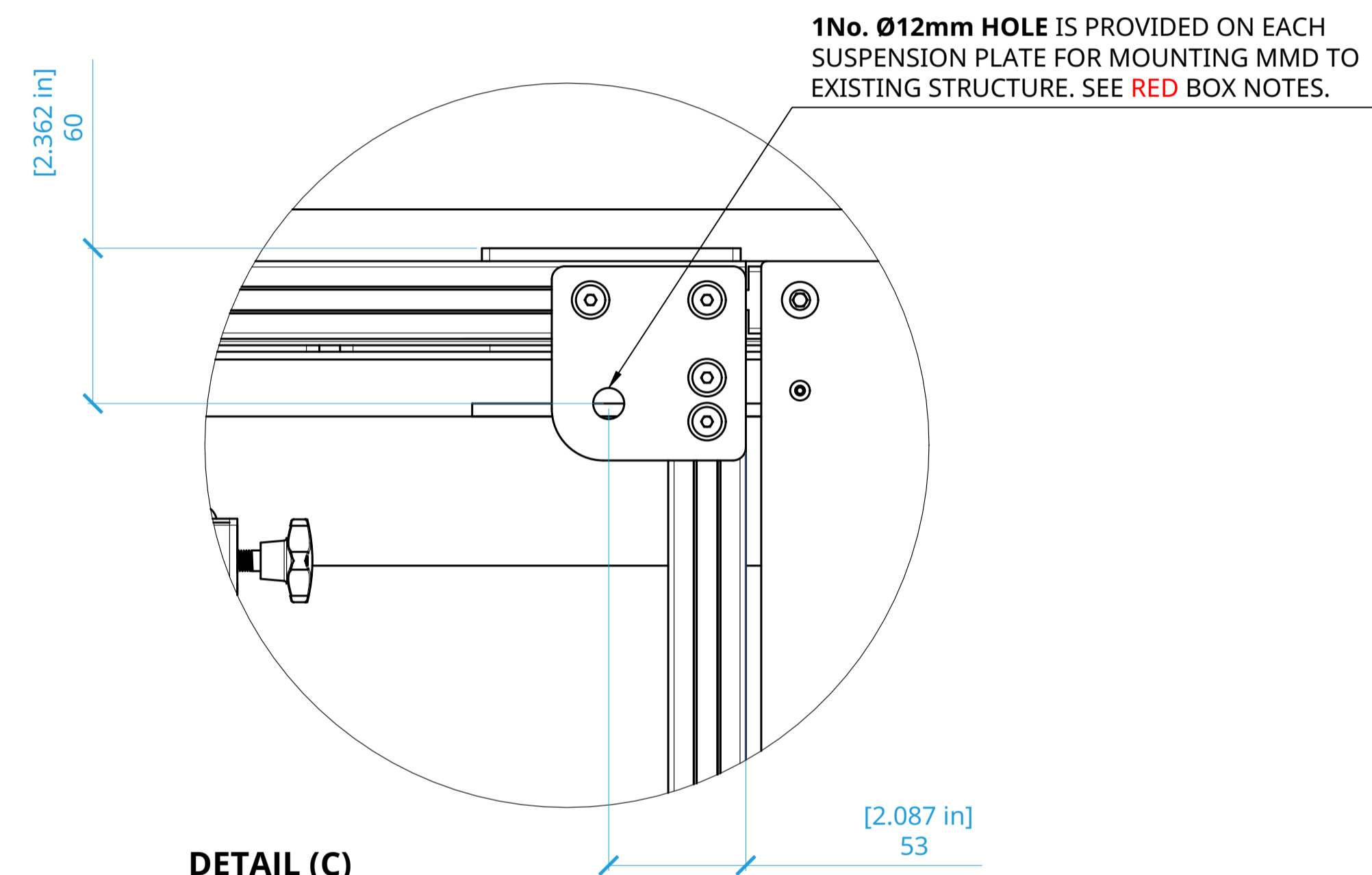

DETAIL (C)
SCALE 1:2 @ A1

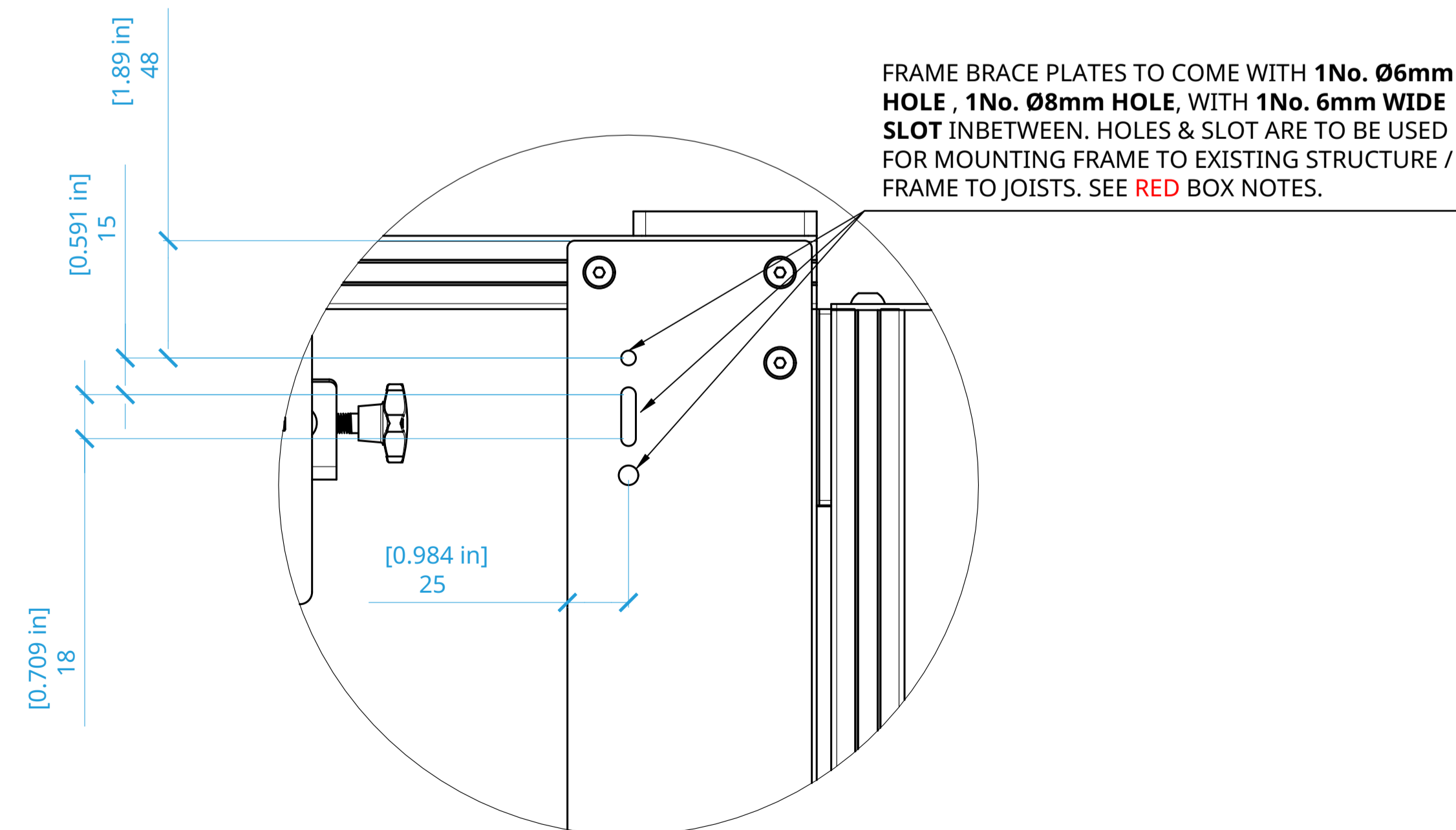

DETAIL (D)
SCALE 1:2 @ A1



NOTES:

- SUPPORTED THROW** FOR THIS PRODUCT IS **[1.3]** - THIS IS CALCULATED FROM FRONT OF MIRROR (RHS DIM LINE) TO SCREEN SURFACE. SEE **RED** BOX NOTE FOR FURTHER CLARITY.
- WHEN CALCULATING LENSES - IT IS IMPORTANT TO REMEMBER THAT THIS PRODUCT **ADDS ~440mm** TO THE LIGHT PATH, COMPARED TO A STANDARD ARRANGEMENT.



THE **MINIMUM PROJECTION DISTANCE** IS CALCULATED AS BELOW

SCREEN WIDTH x SUPPORTED THROW
(SW x 1.3).



NOTES:

- ALL DIMENSIONS ARE IN 'MM' UNLESS SPECIFIED IN "[x]".
- ANY HAZARD SYMBOLS ARE TO BE READ IN CONJUNCTION WITH ANY RISK ASSESSMENT IF NUMBERED.
- THIS DRAWING IS PROPERTY OF DISPLAY TECHNOLOGIES LTD & IS STRICTLY CONFIDENTIAL. THE DRAWING SPECIFICATION & ITS CONTENTS MUST NOT BE DISCLOSED TO ANY THIRD PARTY WITHOUT PRIOR CONSENT.
- DRAWING SCALE IS ANNOTATED ON EVERY VIEW. IF IN DOUBT - ASK THE DESIGNER.
- DISPLAY TECHNOLOGIES RESERVE THE RIGHT TO MAKE DESIGN ALTERNATIONS THROUGHOUT CONTINUOUS PRODUCT DEVELOPMENT - IS IT THE CLIENTS RESPONSIBILITY TO ENSURE THEY REQUEST THE LATEST DESIGN REVISION.

SYMBOLS:



PROVIDES A REFERENCE NUMBER FOR ADDITIONAL NOTATION.



HIGHLIGHTS SPECIFIC MANUFACTURING INFORMATION.



HIGHLIGHTS A HAZARD & OR A RESIDUAL RISK ASSOCIATED WITH THE DESIGN RISK ASSESSMENT.

0 x

REV	DESCRIPTION	DATE	INITIALS
0	ORIGINAL ISSUE.	12.12.23	SR

DESIGNED | CHECKED | APPROVED

S. Ridley | S. Ridley | S. Ridley

12.12.23 | 12.12.23 | 12.12.23

DRAWING STATUS

CLIENT ISSUE

TITLE

GENERAL OVERVIEW

PART NUMBER

[DT-MMD-ST]

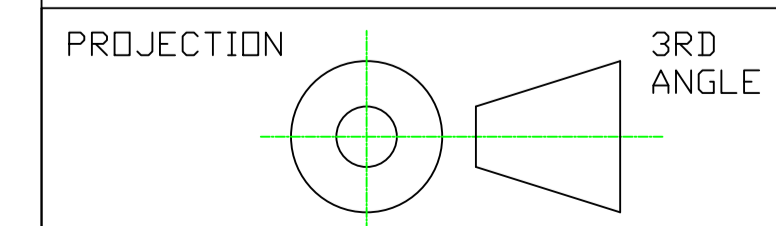

DRAWING No. DR-03 | REV No. 0

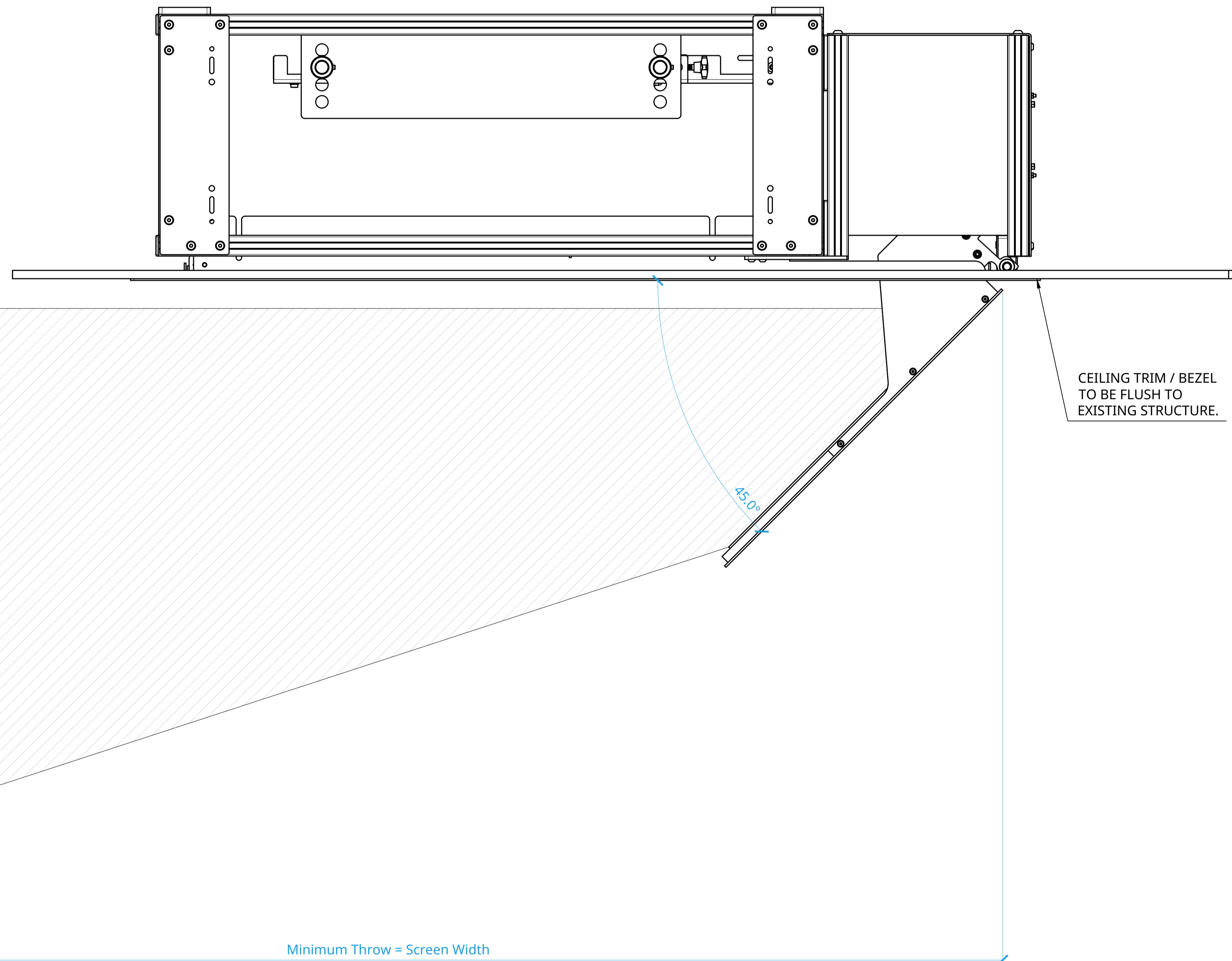

SCREEN

SIDE ELEVATION
DO NOT SCALE.

Minimum Throw = Screen Width

CEILING TRIM / BEZEL
TO BE FLUSH TO
EXISTING STRUCTURE.

45.0°



NOTES:

- SUPPORTED THROW** FOR THIS PRODUCT IS **[1.3]** - THIS IS CALCULATED FROM FRONT OF MIRROR (RHS DIM LINE) TO SCREEN SURFACE. SEE **RED** BOX NOTE FOR FURTHER CLARITY.
- WHEN CALCULATING LENSES - IT IS IMPORTANT TO REMEMBER THAT THIS PRODUCT **ADDS ~440mm** TO THE LIGHT PATH, COMPARED TO A STANDARD ARRANGEMENT.



THE MINIMUM PROJECTION DISTANCE IS CALCULATED AS BELOW

SCREEN WIDTH x SUPPORTED THROW
(SW x 1.3).



NOTES:

- ALL DIMENSIONS ARE IN 'MM' UNLESS SPECIFIED IN "[x]".
- ANY HAZARD SYMBOLS ARE TO BE READ IN CONJUNCTION WITH ANY RISK ASSESSMENT IF NUMBERED.
- THIS DRAWING IS PROPERTY OF DISPLAY TECHNOLOGIES LTD & IS STRICTLY CONFIDENTIAL. THE DRAWING SPECIFICATION & ITS CONTENTS MUST NOT BE DISCLOSED TO ANY THIRD PARTY WITHOUT PRIOR CONSENT.
- DRAWING SCALE IS ANNOTATED ON EVERY VIEW. IF IN DOUBT - ASK THE DESIGNER.
- DISPLAY TECHNOLOGIES RESERVE THE RIGHT TO MAKE DESIGN ALTERNATIONS THROUGHOUT CONTINUOUS PRODUCT DEVELOPMENT - IS IT THE CLIENTS RESPONSIBILITY TO ENSURE THEY REQUEST THE LATEST DESIGN REVISION.

SYMBOLS:

- PROVIDES A REFERENCE NUMBER FOR ADDITIONAL NOTATION.
- HIGHLIGHTS SPECIFIC MANUFACTURING INFORMATION.
- HIGHLIGHTS A HAZARD & OR A RESIDUAL RISK ASSOCIATED WITH THE DESIGN RISK ASSESSMENT.

REV	DESCRIPTION	DATE	INITIALS
0	ORIGINAL ISSUE.	12.12.23	SR

DESIGNED	CHECKED	APPROVED
S. Ridley	S. Ridley	S. Ridley
12.12.23	12.12.23	12.12.23

DRAWING STATUS

CLIENT ISSUE

TITLE

GENERAL OVERVIEW

PART NUMBER

[DT-MMD-ST]

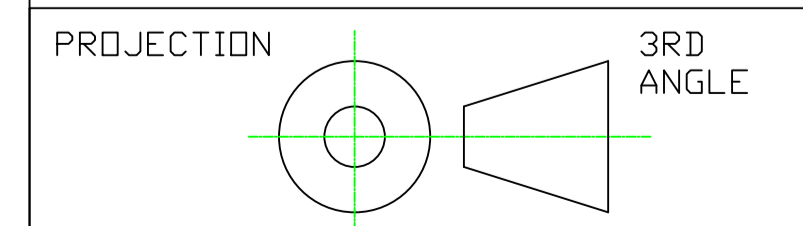

DRAWING No. DR-04	REV No. 0
----------------------	--------------

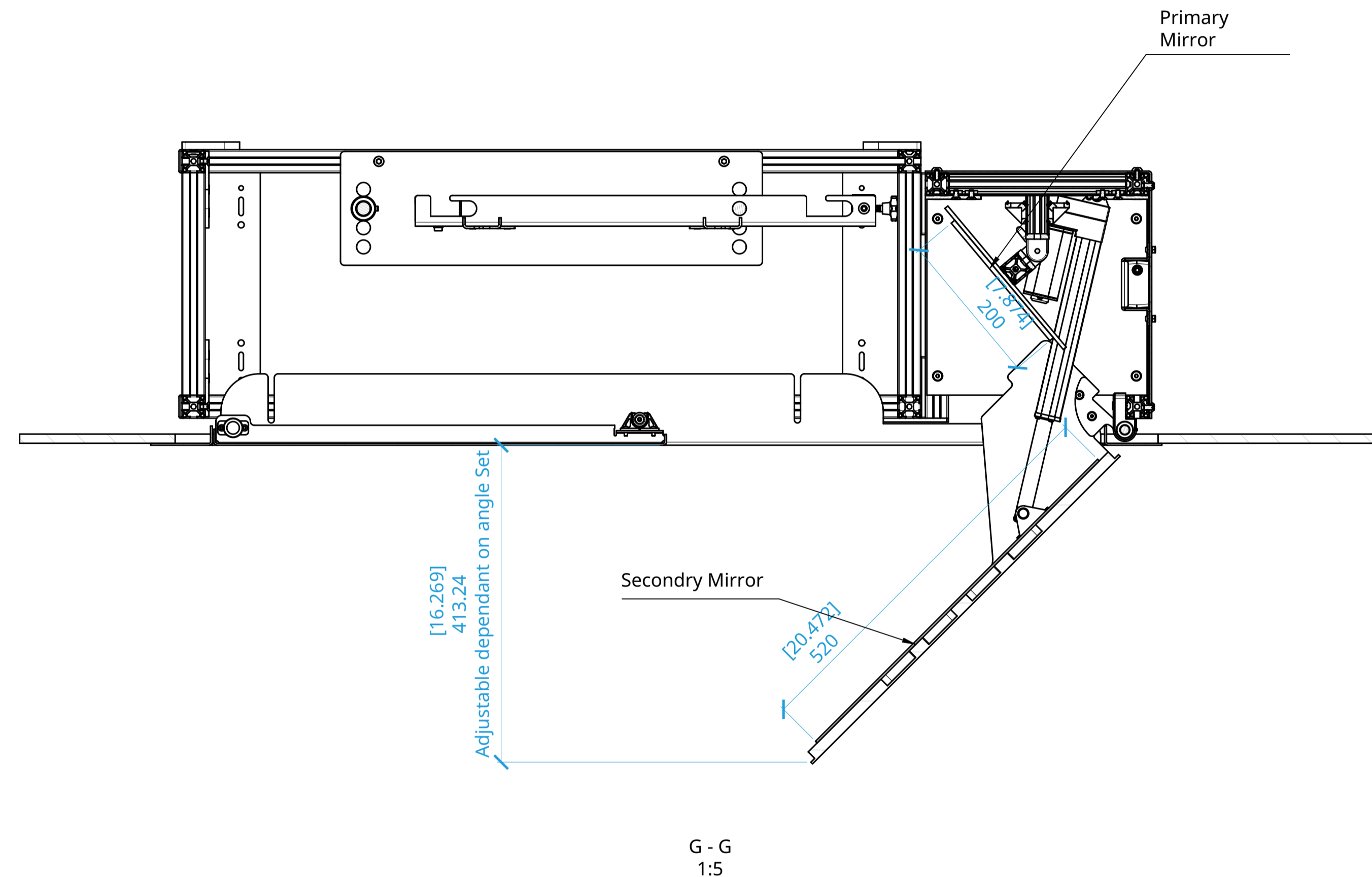
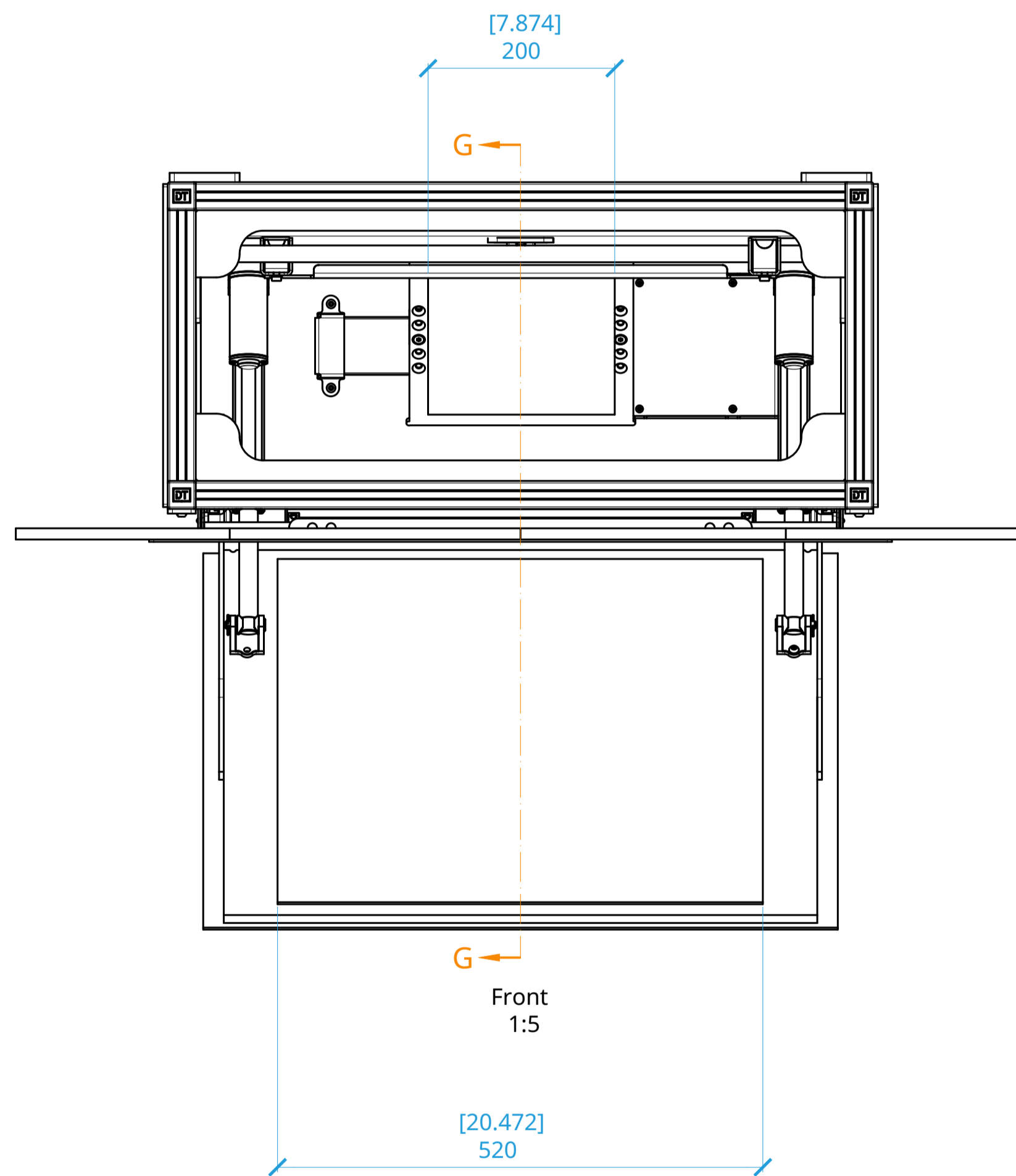



NOTES:

1. THIS PRODUCT IS POWERED USING STANDARD MAINS **IEC 110v-240v AC (50/60Hz)** & IS CONTROLLED USING **IP RS232** OR, **CONTACT CLOSURE**.
2. ALL WIRING IS FED THROUGH TOP ACCESS HOLE IN MIRROR CASING - SEE **DETAIL (F)** FOR FURTHER CLARITY.
3. OPENING DIMENSIONS FOR EXISTING STRUCTURE CAN BE OPENED OUT **+5mm** (EACH SIDE) IF NECESSARY. IN ORDER FOR BEZEL TO CONSEAL OPENING - WIDTH & LENGTH MUST NOT EXCEED **+10mm** BASED ON DIMENSIONS BELOW.



NOTES:

- ALL DIMENSIONS ARE IN "MM" UNLESS SPECIFIED IN "[x]".
- ANY HAZARD SYMBOLS ARE TO BE READ IN CONJUNCTION WITH ANY RISK ASSESSMENT IF NUMBERED.
- THIS DRAWING IS PROPERTY OF DISPLAY TECHNOLOGIES LTD & IS STRICTLY CONFIDENTIAL. THE DRAWING SPECIFICATION & ITS CONTENTS MUST NOT BE DISCLOSED TO ANY THIRD PARTY WITHOUT PRIOR CONSENT.
- DRAWING SCALE IS ANNOTATED ON EVERY VIEW. IF IN DOUBT - ASK THE DESIGNER.
- DISPLAY TECHNOLOGIES RESERVE THE RIGHT TO MAKE DESIGN ALTERNATIONS THROUGHOUT CONTINUOUS PRODUCT DEVELOPMENT - IS IT THE CLIENTS RESPONSIBILITY TO ENSURE THEY REQUEST THE LATEST DESIGN REVISION.

SYMBOLS:

- PROVIDES A REFERENCE NUMBER FOR ADDITIONAL NOTATION.
- HIGHLIGHTS SPECIFIC MANUFACTURING INFORMATION.
- HIGHLIGHTS A HAZARD & OR A RESIDUAL RISK ASSOCIATED WITH THE DESIGN RISK ASSESSMENT.

REV	DESCRIPTION	DATE	INITIALS
0	ORIGINAL ISSUE.	12.12.23	SR

DESIGNED	CHECKED	APPROVED
S. Ridley	S. Ridley	S. Ridley
12.12.23	12.12.23	12.12.23

DRAWING STATUS

CLIENT ISSUE

TITLE

GENERAL OVERVIEW

PART NUMBER

[DT-MMD-ST]

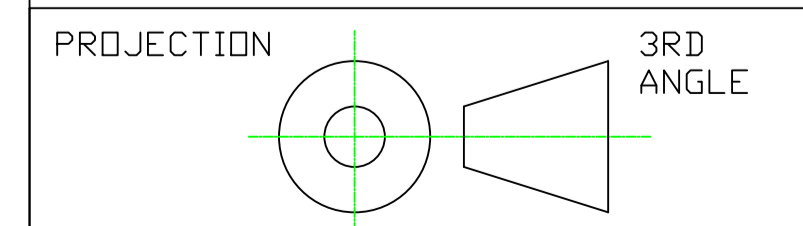

DRAWING No. DR-05	REV No. 0
-----------------------------	---------------------

