

le feu



EVERY HOME DESERVES A WARM HEART

CONGRATULATIONS

with your new Turtle Pizza Oven from Le Feu Fires

Thank you for choosing Le Feu Fires. We hope your new Pizza Oven will contribute to many pleasant moments.

Before you get started, it is highly important that you read and understand this entire user manual.

Le Feu Fires continuously work to ensure the highest product quality. We want to make sure that you always have a safe and secure product experience.

If you have any questions regarding the product after reading this user manual, please contact your local dealer, distributor or Le Feu technical support. Information can be found at www.lefeufires.com

Make sure to handle your Pizza Oven and fuels as described in this user manual, to avoid any accidents.

READ THIS MANUAL BEFORE USE!

We hope you will enjoy your new Le Feu product

Best Regards

A handwritten signature in blue ink that reads "Soren Lauritzen". The signature is written in a cursive, flowing style.

INDEX

DATASHEET - TECHNICAL INFORMATION	4
PACKAGING CONTENT - ASSEMBLY INSTRUCTIONS	6-7
SAFETY INSTRUCTIONS	8-10
USER INSTRUCTIONS	11
MAINTENANCE	12
TROUBLESHOOTING	13
WARRANTY	14-15

LE FEU TURTLE - DATA SHEET

Manufacture	Le Feu By Lauritsen Aps		 2531	
Address	Algade 31, 4 sal - 9000 Aalborg - Denmark			
Application name	Le Feu Turtle			
Model No.	830001			
Heat output	3,2 kW			
Gas category	I3+(28-30/37)	I3B/P(30)	I3B/P(37)	I3B/P(50)
Types of gas	G30/G31	G30/G31	G30/G31	G30/G31
Gas pressure	Butane: 28-30 mbar propane: 37 mbar	28-30 mbar	37 mbar	50 mbar
Contry of destination	BE, CH, CY, CZ, ES, FR, GB, GR, IE, IT, LT, LU, LV , PT, SI, SK	AL, BG, CY, DK, EE, FI, FR, HU, HR, IS, IT, LT, LU, MT, MK, NL, NO, RO, SK, SI, SE, TR	PL	AT, CH, DE, SK
Burner injector	0,77 mm	0,77 mm	0,72 mm	0,67 mm
Gas consumption (g/h)	320 g/h			
This manual is for:	830001			

PIN NO. 2531DN-0009

This application must be installed in accordance with the rules in force, and used only in a sufficiently ventilated space. Consult instructions before installation and use of this application.

WARNING: THIS APPLIANCE HAS AN OPEN FLAME, A SUITABLE GUARD SHOULD BE USED FOR THE PROTECTION OF YOUNG CHILDREN, THE ELDERLY AND THE INFIRM.

- Close the valve of the gas cylinder or the regulator after use.
- Read the instructions before using this appliance. For outdoor use only in well ventilated areas.
- The use of this appliance in enclosed areas can be dangerous and is PROHIBITED.
- The appliance must be installed in accordance with the instructions and local regulations.
- A well ventilated area must have a minimum of 25% of the surface area open. The surface area is the sum of the walls surface.
- This appliance must use an EN16129 approved gas regulator and EN16436-1

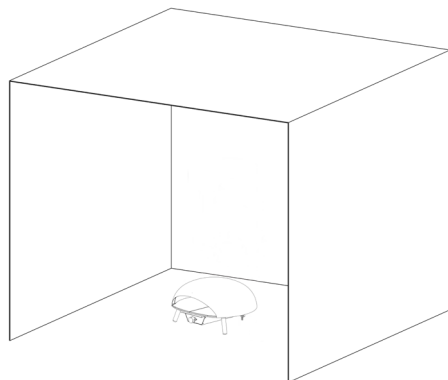



PACKAGE CONTENT

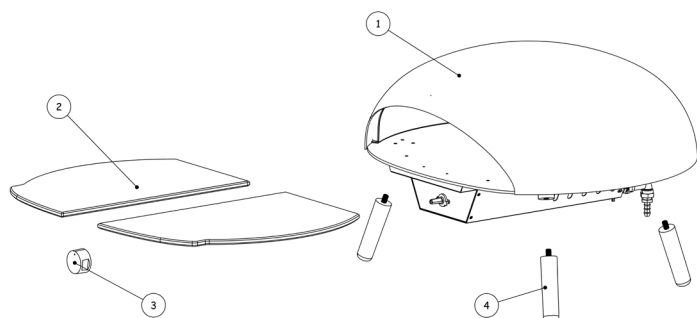

1. Body - 1 pc



2. Stone - 2 pc



3. Knob - 1 pc



4. Leg - 3 pc

ASSEMBLY INSTRUCTIONS

STEP 1:

Place the leg (part 4) over the bottom plate as shown and fasten it. Put the AA battery (battery is NOT included) into the battery box as shown in the figure below.

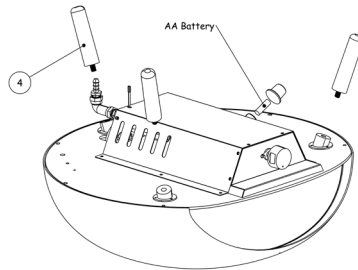

STEP 2:

Put the stone (part 2) and the knob (part 3) into the body as shown in the figure below.

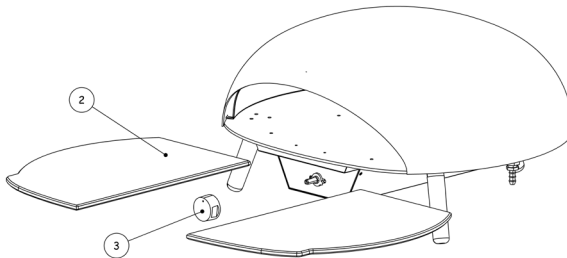

IMPORTANT SAFETY INSTRUCTIONS



Before using this product, it is important that you follow the step-by-step instructions on the following pages.

IMPORTANT: FOR OUTDOOR USE ONLY

1. Incorrect installation, adjustment, service or maintains can cause property damage, injury, or death.
2. Read the installation, operating and maintenance instructions thoroughly before installing or servicing the Pizza Oven.
3. **WARNING:** The Pizza Oven will become very hot. Do not move during operation.
4. **WARNING:** The Pizza Oven has an open flame, a suitable guard should be used for the protection of young children, the elderly and the infirm.
5. Never leave the Pizza Oven unattended.
6. Only use the Pizza Oven on a level surface.
7. Turn off the gas supply after use.
8. Any modification of the Pizza Oven may be dangerous and will void the warranty.
9. Do not replace the grill with an extra hotplate. The warranty will be voided, and it is in violation of the gas approval. The grill provides the ventilation needed for the Pizza Oven to operate safely. It is not designed to be a solid hotplate device.
10. Please ensure all packaging and transit protection materials are removed prior to using the Pizza Oven.
11. Do not use the Pizza Oven in a confined or enclosed space such as a garage, carport, tent, marquee, to avoid risk of fire and the accumulation of smoke and fumes.



FOR YOUR SAFETY

If you smell gas:

1. **Shut off gas to the appliance.**
2. **Extinguish any open flame.**
3. **Open lid.**
4. **If odour continues, immediately call your gas supplier.**
5. **Do not store or use gasoline or other flammable vapours or liquids in the vicinity of this or any other appliance.**
6. **A gas cylinder not connected for use shall not be stored in the vicinity of this or any other appliance.**

12. Strong winds and low temperatures can affect the heating and performance of your Pizza Oven
13. Do not obstruct the flow of ventilation air around the Pizza Oven housing. This Pizza Oven is not intended to be installed in or on recreational vehicles and/or boats.
14. This Pizza Oven must be installed in accordance with the installation instructions provided by the manufacturer, local gas fitting regulations and other relevant statutory regulations.
15. Please check for gas leakage the first time you are connecting the Pizza Oven to the gas cylinder, and each time you are replacing the gas cylinder or disconnecting/reconnecting any fittings. Inspect the hose before each use.



This Pizza Oven should not be located under overhead combustible construction and proper clearances must be always maintained from combustible construction and/or materials, with MINIMUM clearances as follow:

From Sides:	450 mm
From Back:	450 mm
Above:	1000 mm

LEAK TESTING:

1. Add soap and water to a spray bottle or soapy water with a brush.

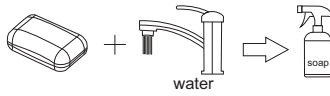

2. Turn off the gas valve in the front of the Pizza Oven.

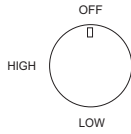

3. Turn on the gas cylinder. Add soap and water to a spray bottle or soapy water with a brush.



4. Spray or apply soapy water on the gas connections. If a leak is present bubbles will appear.



USER INSTRUCTIONS

1. Lightning the Pizza Oven. Make sure all gas connections are securely tightened.
2. Check that the gas cylinder/regulator is turned on.
3. This Pizza Oven is equipped with automatic ignition, push the knob in and turn anticlockwise to high position. You should hear a clicking sound from the igniter, hold the knob in until the burner ignites. If the burner does not light on first attempt, return the knob to off position, and try a couple of more times.
4. The knob has three basic positions. You can achieve any flame height between low and high by rotating the knob between these positions.

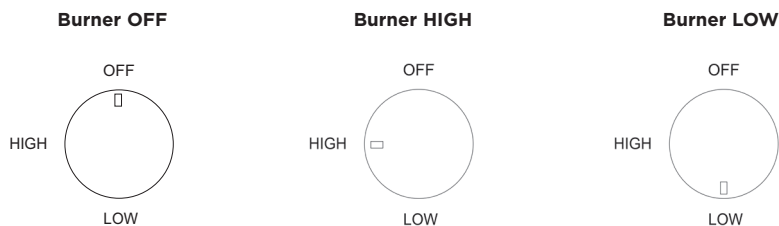

5. When finishing cooking, leave the Pizza Oven on high position up to 5 minutes so that remaining grease from the food will be removed.
6. When turning off the Pizza Oven, close the main supply from the gas cylinder first; this will allow the remaining gas in the hose to evaporate. The burners can then be turned off.
7. Always ensure that the Pizza Oven has cooled down before cleaning. Hot surfaces may cause serious burns or injuries. If the Pizza Oven is still hot use gloves for protection.

NOTE: Blowback is a situation where the flame burns inside the burner, towards the front. This can be recognized by a sharp roaring sound coming from the burner. It is not dangerous. If this occurs, simply turn off the burner, wait a few seconds and then relight.

MANUAL IGNITION

If the battery is low on power, it is possible to manually light the Pizza Oven.

1. Place a lighted match or gas lighter on top of the burner. (not provided)
2. Keep your hand below the bottom of the burner while doing this.
3. Turn the power to HIGH position
4. You should see the burner alight

MAINTAINANCE

1. Your Pizza Oven should be kept clean to prevent deterioration and it will look better and last longer if you keep the Pizza Oven clean.
2. The Pizza Oven should be regularly cleaned and be protected by a fitted cover (accessories) when not in use. Clean the Pizza Oven thoroughly on a regular basis.
3. On regular basis it's recommended to brush the burner to keep the holes clean and prevent blocking.
4. In freezing periods it's recommended to store the baking stone inside under dry and warm conditions.
5. When not used store your Pizza Oven in dry condition.



Please note: Always allow Pizza Oven to cool completely before covering with an outdoor weather cover. Likewise prior to service and maintenance.



TROUBLESHOOTING

PROBLEM	POSSIBLE CAUSE	CORRECTIVE ACTION
The Pizza Oven will not ignite	Battery is missing in the batterybox	Put a AA-battery in the batterybox
	Gas cylinder is turned off, or not correct mounted.	Check that the regulator is correctly mounted and turn the gas cylinder ON.
	Control knob is not in "HIGH" position	Turn the control knob to "HIGH" position (see page 11)
The burner flame is too low	The gas pressure is low	Turn the cylinder valve off and replace the cylinder
	The outdoor temperature is less than 40°F/4.5°C .	Use a full gas cylinder
		Check the burner ports for blockage

WARRANTY

- Our Pizza Oven are guaranteed for one year of part replacement. The warranty is valid from the date of purchase.
- Warranty will be applied on presentation of a dated cash receipt or invoice and is strictly limited to factory service repair of the piece(s) that are found to be defective.
- The manufacturer will not be held responsible for any incidental or consequential defects on goods or individuals.
- The warranty will not be applied if the product have been subjected to abnormal use or if used under other conditions of use than the ones they were intended for.
- The warranty will not apply in case of deterioration or accident due to negligence, damages caused by failing to maintain and service the device or resulting from an alteration of material.
- The manufacturer guarantees the product, with the exception of the following parts, which are subjected to normal wear and tear, for 1 year from the date of purchase, as stated in: Proof of document (invoice and/or receipt) stating the seller's name and the date of sale. The Le Feu Pizza Stones are not covered by any warranty.
- The warranty is valid provided that the instructions and warnings in the operating and maintenancemanual accompanying the Pizza Oven are observed to be used in the most correct way.
- The warranty covers free replacement or repair of parts found defective due to manufacturing defects.
- Complaints are made through the dealer from whom the Pizza Oven is purchased.
- The manufacturer disclaims any responsibility for any direct or indirect damage to persons, animals or objects caused by non-compliance with the instructions contained in the instructions for use, in particular the instructions regarding installation, use and maintenance of the Pizza Oven.
- Burner, steel bowl, all mechanical parts and fittings to control panel and burner assembly, and all parts that are not cast aluminum are warranted against defects in materiale and/or workmanship for a period of one (1) year from original date of purchase. Rust is not covered.
- The surface of the Pizza Oven is warranted against peeling, cracking or blistering for a period of one 1 year provided the product has not been scratched or abraded. Scratches and chips resulting from normal wear and tear are not covered. Please use the original Le Feu Turtle Cover to protect the product.
- Fading from exposure to elements, e.g. sunlight, is not covered. Stains as a result of chemical spills and food items are not covered.
- Pizza Oven sold as clearance items, display models or items purchased in an "as is" condition,

freight damage, firepit damaged by acts of nature, vandalism, fire, abuse, lack of proper care and maintenance or improper assembly. Straps and normal fading or discoloration from exposure to elements, oils, spills, fluids or chemicals. Also excluded is loss of use of time and/or inconvenience, money, travel, packaging or any other consequential or incidental damages.

- Le Feu Fires can't be held responsible to exceed the value of the replacement product. Warranty is to the original purchaser when items are purchased from one of our authorized retailers and is not transferable.





WWW.LEFEUFIRES.COM