



VLF

Ventless Hood for use with Full Size Electric Convection Ovens

HOODINI
by **BLODGETT**



Shown on Mark V-200 double with optional casters



Project _____
Item No. _____
Quantity _____

FEATURES & BENEFITS

- The Hoodini convection hood collects and filters exhaust from the oven cavity(ies). The “scrubbed” air is then returned to the kitchen.
- Works in conjunction with a catalyst ring which reacts with grease laden vapor before it escapes the hood.
- The system is connected to the ovens using duct work to pull the oven exhaust up and into the hood.
- Allows you to think outside of the designated hood space in the kitchen.
- Maximize your kitchen space with this 0” required top clearance
- Power is provided from the oven, no additional electrical supply is needed.
- No water or drain required.
- Ships with one hood filter. Replacement filters available.

AVAILABLE FOR

- Mark V-100 standard depth convection oven
- Mark V-200 bakery depth convection oven
- Zephaire-100-E standard depth convection oven
- Zephaire-200-E bakery depth convection oven

VENTILATION

- UL (KNLZ) listed for ventless operation
- Using EPA test method 202, emissions of grease laden vapors were measured at .67 mg/m³ for bone-in, skin-on, quartered roasting chickens. Results are less than the established 5 mg/m³ standard.
- Heat gain
 - Standard Depth Convection: 2,178 Watts
 - Bakery Depth Convection: 2,319 Watts

WARRANTY

- See oven warranty

HOOD SHIPPING INFORMATION

Approx. Weight 160 lbs. (73 kg)
Crate Size 38.5” (978mm) x 40” (1016mm) x 20” (508mm)

NOTE: The company reserves the right to make substitutions of components without prior notice

VLF - FULL SIZE CONVECTION VENTLESS HOOD

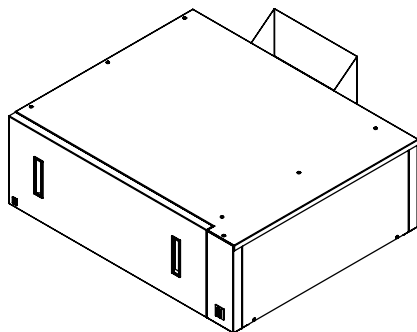

DIMENSIONS ARE IN INCHES (MM)

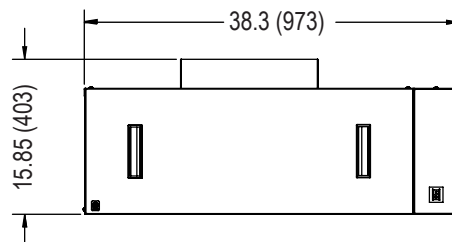

FRONT VIEW

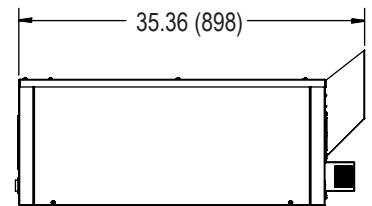

SIDE VIEW



VLF - FULL SIZE CONVECTION VENTLESS HOOD

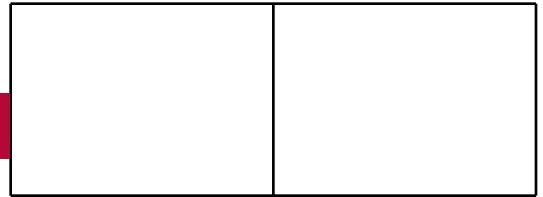

APPROVAL/STAMP

HOODINI CONVECTION HOOD ON MARK V-100 OR ZEPHAIRE-100-E STANDARD DEPTH OVENS

DIMENSIONS ARE IN INCHES (MM)
See oven spec sheets for complete oven information.

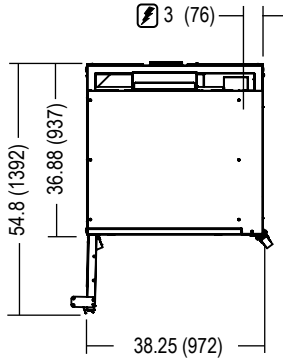

TOP VIEW

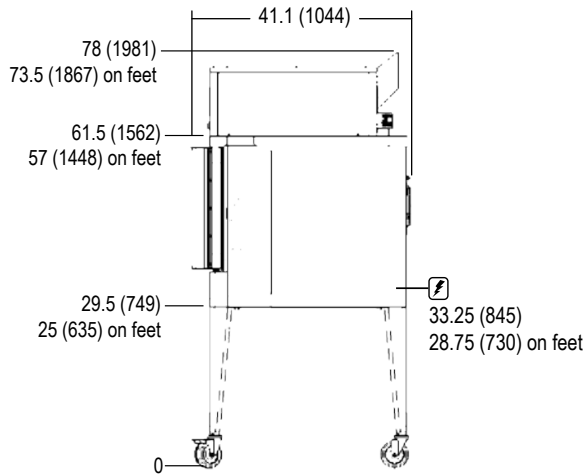

SINGLE
(Shown on optional casters)

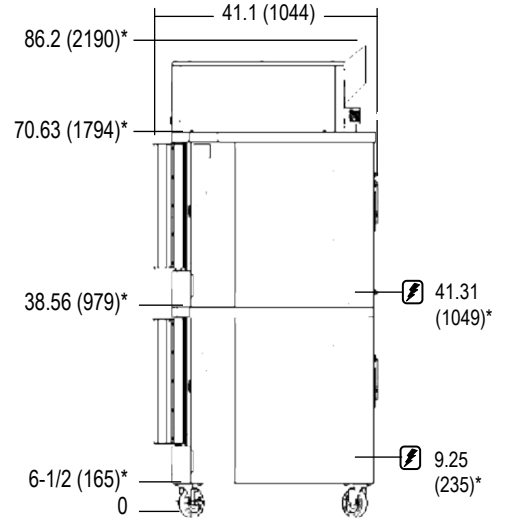

DOUBLE
(Shown on optional casters)

* For double stack models, height dimensions for legs or casters are the same. For low profile casters, subtract 2.5" (64mm) from all height dimensions.

HOODINI CONVECTION HOOD ON MARK V-200 OR ZEPHAIRE-200-E BAKERY DEPTH OVENS

DIMENSIONS ARE IN INCHES (MM)
See oven spec sheets for complete oven information.

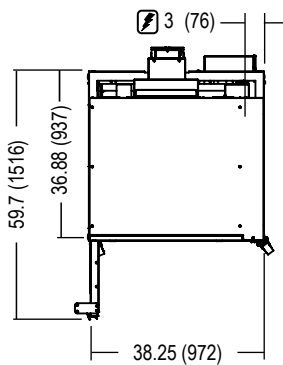

TOP VIEW

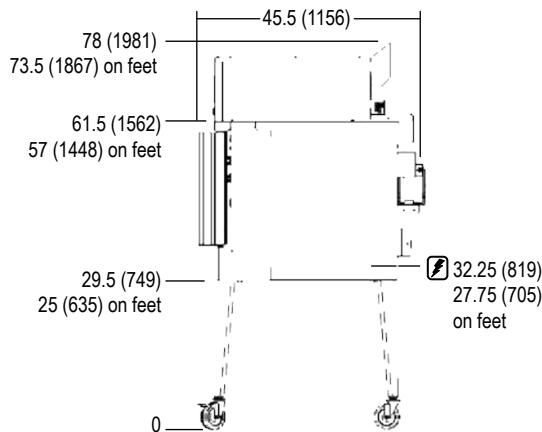

SINGLE
(Shown on optional casters)

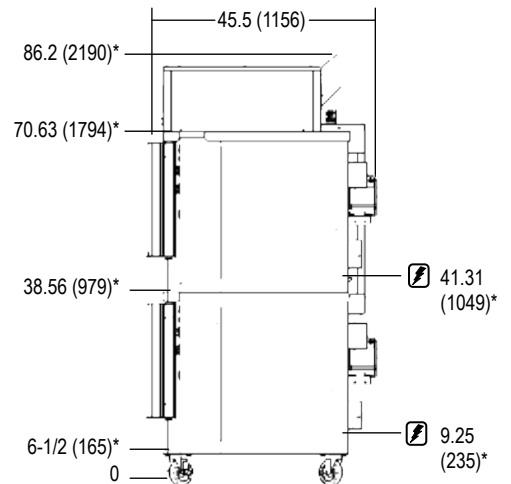

DOUBLE
(Shown on optional casters)

* For double stack models, height dimensions for legs or casters are the same. For low profile casters, subtract 2.5" (64mm) from all height dimensions.