

L-EM-DADO

Kugelgelenke mit Schraubenmutter

Für ZUGLAST (DRUCKLAST)-Wägezelle



GEWINDE	WERKSTOFF	KN LASTKAPAZITÄT STATISCH	NETTOGEWICHT (kg)	ARTIKELNUMMER
M12	Edelstahl	24.5	0.08	L-EM-INOX
M16		45	0.19	
M20		60	0.30	
M24		83	0.60	
M6	Verzinkter C45-Stahl	8.1	0.02	L-EM
M8		12.9	0.04	
M10		17.6	0.06	
M12		24.5	0.08	
M16		45	0.19	
M20		60	0.30	
M24		83	0.60	
M36		146	1.45	

ABMESSUNGEN

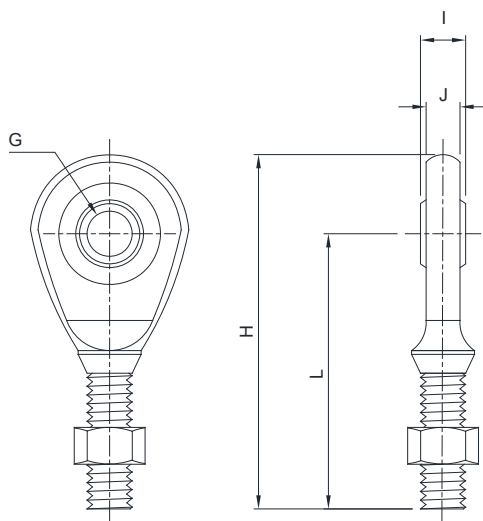

Edelstahl

THREAD	G	H	I	J	L
M12x1.75	Ø12	72	10	8.5	55
M16x2	Ø17	88.5	14	11.5	65.5
M20x1.5	Ø20	104	16	13.5	77
M24x2	Ø25	124	20	18	92

Verzinkter C45-Stahl

M6x1	Ø6	47	6	4.5	36.5
M8x1.25	Ø8	54	8	6.5	42.5
M10x1.5	Ø10	62.5	9	7.5	48.5
M12x1.75	Ø12	71	10	8.5	54.5
M16x2	Ø17	92	14	11.5	69.5
M20x1.5	Ø20	104.5	16	13.5	77.5
M24x2	Ø25	126	20	17.5	94.5
M30x2	Ø30	146.5	22	19.5	110
M36x3	Ø35	181	25	21.5	140

Technische Änderungen vorbehalten. Alle Angaben beschreiben unsere Produkte in allgemeiner Form und sind ohne Gewähr.

