

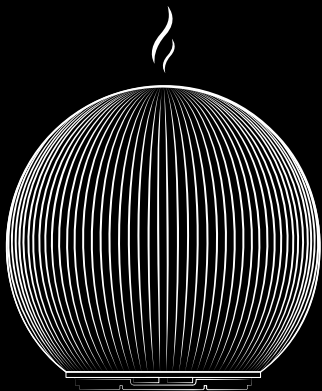

MADE BY ZEN®



CHI

Ceramic aroma diffuser with a soft ambient light  
and multiple breathing modes to aid mindfulness

Find peace, energy and vitality to awaken your Chi ...

# **TABLE OF CONTENTS:**

**A. ABOUT THE CHI**

**B. TECHNICAL SPECIFICATION**

**C. OPERATING INSTRUCTIONS**

**D. FEATURES**

**E. MAINTENANCE**

**F. TROUBLESHOOTING**

**G. WARRANTY**

**Congratulations on purchasing your MADE BY ZEN® Chi Aroma Diffuser. Please refer to this manual to help you get the most out of your Chi and for maintenance.**

# A - ABOUT THE CHI

Create balancing and calming rituals with mindfulness and breathwork practices. Crafted from natural ceramic, the Chi radiates delicate veins of light through the translucent cover, creating a therapeutic and relaxing aura.

With three unique breathing settings, follow as the soothing light dims and brightens to guide you through mindful breathing techniques. The Chi's soothing aromatherapy mist fills the air with scent, perfect with fragrance or essential oils for nourishing aromatherapy. Find peace, energy and vitality to awaken your 'Chi'.



Warm, ambient LED lighting which can help you to relax.

- Soft glow, fixed ambient light
- Sleep mode (no light) option



Constant Mist & Intermittent Mist setting, ideal for diffusing stronger scents or getting a strong burst of fragrance or humidity into the air.



Breathing light with multiple settings to aid breathwork practices for mindfulness and relaxation.

- Balance breath
- Release breath
- Clarity breath



Remote Control



Suitable for use with any essential or fragrance oils (MADE BY ZEN® oils recommended)

# B - TECHNICAL SPECIFICATION

**Model Name:** Chi Aroma Diffuser

**Model No:** EW055-1

**Product Size:** Ø165 x 156mm

**Voltage:** DC 24V

**Power:** 12W

**Water Capacity:** 120ml

**Run Time:** 6+ hours

01. Ceramic Cover

02. Mist Outlet

03. Inner Cover

04. Water Tank

05. Light Button

06. Mist Button

07. Max. Water Level Line

08. Air Vent

09. Ceramic Disc

10. Drainage Direction

11. DC Jack

12. Adaptor

13. Remote

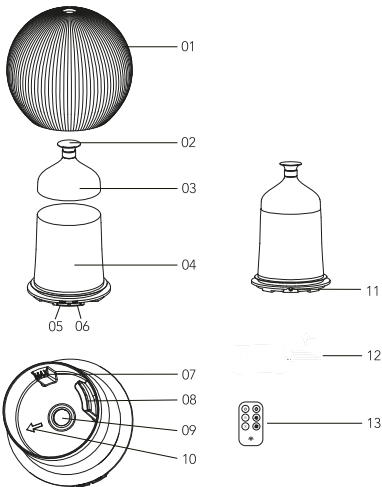

# IMPORTANT NOTES BEFORE

The Aroma Diffuser **MUST** be cleaned before and after each use. When stored the unit should **always** be kept clean and dry. **NEVER** leave stagnant oil and water in the water tank for any prolonged period.

Whilst using your diffuser, you **MUST** clean the water tank every 3 days:



**Micro-organisms that may be present in the water or in the environment where the appliance is used or stored, can develop in the water reservoir, and expelled into the air when next used causing very serious health risks. To prevent this the water tank **MUST** be cleaned properly every 3 days.**

Der Aromadiffuser **MUSS** vor und nach jeder Verwendung gereinigt werden. Das Gerät sollte immer in einem sauberen und trockenen Zustand gelagert werden. Lassen Sie **NIE** über einen längeren Zeitraum Öl und Wasser im Wassertank stehen.

Während der Verwendung Ihres Diffusers **MÜSSEN** Sie den Wassertank **alle** drei Tagen reinigen:



**Eventuell im Wasser oder der Umgebung, in der das Gerät verwendet bzw. gelagert wird, vorhandene Mikroorganismen können sich im Wassertank weiterentwickeln, bei der nächsten Verwendung in die Luft austreten und somit äußerst ernsthafte Gesundheitsrisiken hervorrufen. Zur Vermeidung dessen **MUSS** der Wassertank alle drei Tage ordentlich gereinigt werden.**

يجب تنظيف الفواحة العطرية قبل وبعد كل استعمال. في حال حفظ وتخزين الجهاز، يجب دومًا المحافظة عليه نظيفًا وجافًا. لا تترك بقايا الزيت والماء الراكد أبدًا في خزان الماء لمدة طويلة جدًا.

أثناء استعمال الفواحة العطرية، يجب عليك تنظيف خزان الماء كل ٣ أيام.



يمكن للكائنات الدقيقة التي قد تكون موجودة في الماء أو في البيئة في حال استخدام الجهاز أو تخزينه أن تنمو في خزان الماء، وتنتشر في الهواء، وسوف يتسبب الاستعمال التالي للجهاز بأخطار صحية كبيرة جدًا. لحماية خزان الماء، يجب لتظيفه على نحو ملائيم كل ٣ أيام (٧٢ ساعة).

1. Place the Aroma Diffuser on a flat surface, at least 60cm away from the floor and at least 10cm away from the wall. DO NOT place the Aroma Diffuser on wooden or polished furniture that may be damaged by water moisture.
2. Always unplug the Aroma Diffuser from the mains electrical supply when cleaning or filling with water. Always use the power adaptor supplied. Ensure the cable is secure to avoid tripping or knocking over the Aroma Diffuser. If the power adaptor is damaged, it must be replaced with a suitable adaptor provided by the manufacturer or its agent. Alternatively, a new adaptor can be purchased from your retailer.
3. Use a suitable measuring cup to fill the water into the water tank. Never attempt to fill water under a running tap or whilst plugged in. Do not fill the water beyond the max water level line. If overfilled, carefully remove the excess water from the tank in the 'drainage direction' as shown by the arrow and away from the vent hole.
4. The Aroma Diffuser must be kept out of reach from children and pets to avoid risk of injury. Children should be supervised at all times to ensure they do not play with the appliance.
5. The Aroma Diffuser is not intended for use by persons (including children) with reduced physical, sensory or mental capabilities or lack of experience and knowledge, unless they have been given supervision or instruction concerning use of the appliance by a person responsible for their safety.
6. Keep the Aroma Diffuser in a clear space to allow the mist to freely spread and away from appliances especially those sensitive to water to avoid unnecessary accidents.
7. The Aroma Diffuser must be cleaned after each use and should always be kept clean and dry when not in use. Never leave stagnant oil and water in the water tank for prolonged periods.
8. Never attempt to disassemble your Aroma Diffuser or repair the product, as this will void your warranty and create a shock hazard. Contact your retailer if an internal inspection is required.

9. In case of abnormal observations such as smoke, peculiar smells or noise, stop using the Aroma Diffuser immediately and contact the retailer from where you purchased it. Never wrap the aroma diffuser or adaptor with cloth or paper as blocking ventilation could increase the risk of fire.

10. Always handle the Aroma Diffuser with care – accidental damage is not covered under the warranty.

11. Always use water at room temperature and use only fresh, clean water from a reliable source. Do not fill the water tank with other chemicals or liquids other than water and a few drops of fragrance or essential oils.

12. Never touch the water within the water tank when the diffuser is in operation as the water may become warm. It is perfectly normal for the water temperature to increase over time. Especially if it has been running for a few hours. This is caused by the energy created from the vibrating disc. The water should not exceed 40°C but for some models it can increase to 50°C (+/- 5°C). However, as the mist dissipates from the mist outlet, the water temperature cools rapidly due to the large surface area of each droplet, hence the mist is referred to as a 'cool mist'.

13. Always plug the adaptor into the DC jack before plugging into the mains.

14. Do not remove the cover during operation.

15. NEVER touch the ultrasonic ceramic disc while the diffuser is plugged in as this could cause serious injury.

16. Do not immerse the unit in water or other liquids and do not attempt to clean in a dishwasher.

17. Remove the plastic insert to activate the battery before using the remote control (as shown on the right) The remote comes with the battery already fitted.





# C - OPERATING INSTRUCTIONS

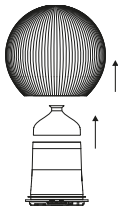

1. Place the diffuser upright on a firm and flat surface. Carefully remove the ceramic cover and inner cover upward as shown.

DO NOT EXCEED  
THE MAX WATER  
LEVEL LINE

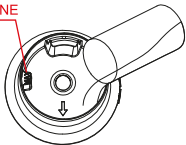

2. Add water to the water tank with a suitable measuring cup until the water reaches the max. water level line as shown.



3. Add 3-5 drops of your favourite fragrance or essential oil into the water.

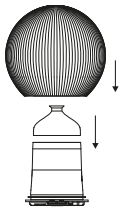

4. Replace the inner cover followed by the ceramic cover.

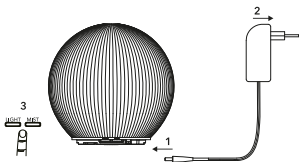

5. Plug the cable into the DC Jack before connecting the adaptor to the power source.

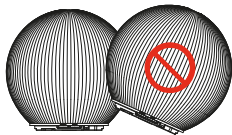

**Note: Do not lean or move or attempt to empty or refill the diffuser during operation.**

## BUTTON FUNCTIONS

The buttons on the base of the Chi can be used when your remote is not available.

### LIGHT CONTROL

The Chi's ambient light will brighten and dim to guide you through multiple breathing exercises, simply follow the light sequences to mimic and control your breath.

#### BALANCE BREATH

A harmonising rhythm of equal 5 second cycles with a slow and steady inhale...and exhale. The Chi will slowly brighten and dim to guide you through this simple sequence. Also known as "Equal Breathing", Balance Breath helps to quieten the mind and find a moment of mindfulness.



## RELEASE BREATH

A powerful breathing technique of short inhales, followed by a lengthy and releasing exhale. Also known as '2:1 Breathing', this sequence comes deep from within to control your exhale to breathe out tension, stress and find inner peace. The Chi will gradually cycle from bright to dim to inhale for 3 seconds, exhale for 6 seconds.



## CLARITY BREATH

Also known as 'Box Breath', Clarity Breath slows down your breathing cycle, calming the nervous system for those stressful moments. The Chi will brighten and dim in 3 second cycles to inhale and hold...exhale and hold. For this practice you should inhale or exhale whilst the light is on and hold when the light turns off.

- > **Press once** to switch on the fixed ambient light.
- > **Press twice** to activate the balance breath light mode.
- > **Press three times** to activate the release breath light mode.
- > **Press four times** to activate the clarity breath light mode.
- > **Press five times** to switch off the light function.

**NOTE: At any point press and hold the light button for 3 seconds to switch off the light.**

## MIST CONTROL

> **Press once** to activate the high mist function. The aroma diffuser will operate until the water level runs low, at this point the Chi will switch off automatically.

> **Press twice** to activate the intermittent mist function. The aroma diffuser will mist intermittently; 20 seconds on/40 seconds off. The aroma diffuser will operate until the water level runs low, at this point the Chi will switch off automatically.

> **Press three times** to turn off the mist function.

## REMOTE CONTROL

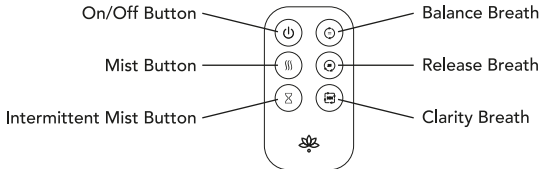

 On/Off Button

Switch on the Chi, using the On/Off button on the remote control panel

> **Press once** to switch on the unit, the fixed ambient light will switch on.

> **Press twice** to switch off the unit.

## BALANCE BREATH

(This button will activate only after switching on the unit using the On/Off Button)

- > **Press once** to activate the balance breath light mode.
- > **Press twice** to fix the light on your preferred intensity.
- > **Press three times** to switch the light off.

## RELEASE BREATH

(This button will activate only after switching on the unit using the On/Off Button)

- > **Press once** to activate the release breath light mode.
- > **Press twice** to fix the light on your preferred intensity.
- > **Press three times** to switch the light off.

## CLARITY BREATH

(This button will activate only after switching on the unit using the On/Off Button)

- > **Press once** to activate the clarity breath light mode.
- > **Press twice** to fix the light on your preferred intensity.
- > **Press three times** to switch the light off.

## ))) CONSTANT MIST BUTTON

(This button will activate only after switching on the unit using the On/Off Button)

> **Press once** to activate high mist function. The aroma diffuser will operate until the water level runs low, at this point the Chi will switch off automatically.

> **Press twice** to activate low mist function. The aroma diffuser will operate until the water level runs low, at this point the Chi will switch off automatically.

> **Press three times** to switch off the mist function.

## ⌄ INTERMITTENT MIST BUTTON

(This button will activate only after switching on the unit using the On/Off Button)

> **Press once** to operate the intermittent mist function. The aroma diffuser will mist intermittently; 20 seconds on/40 seconds off.

> **Press twice** to turn off the intermittent mist function.

## D - FEATURES

The Chi ultrasonic Aroma Diffuser provides a revolutionary way to fragrance your surroundings. It works by creating high frequency vibrations that breaks down the water and oil into minute particles which are then effectively diffused into the immediate surroundings.

- Natural tactile ceramic cover
- Guided breathing exercises, simply follow the light sequences to mimic and control your breath.
- Aroma Diffuser: can be used with ambient lighting or without, ideal for night time use
- Low energy LED ambient lights
- Remote control
- Mini humidifier
- Quiet operation
- Auto-shut off when water runs out for an additional safety
- Easy to clean and use

# E - MAINTENANCE

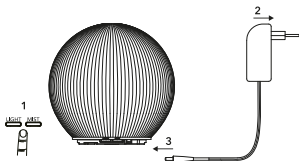

1. Make sure the unit has been switched off and unplug the power from the mains.

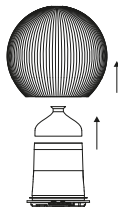

2. Remove the ceramic cover and inner cover upward carefully as shown.

**DO NOT EMPTY WATER FROM THE SIDE OF THE VENT HOLE**

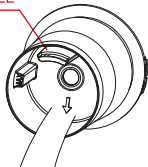

3. Empty water via the water drainage side as shown by the arrow at the base of the water tank.

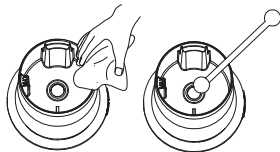

4. Use a clean swab or cloth to clean the unit.



**Caution:** Always switch off the appliance and disconnect the power source from electrical outlet before cleaning.

Always keep your Aroma Diffuser clean and dry when not in use. Never leave stagnant oil and water inside the tank for prolonged periods. If the aroma diffuser stops generating mist (or generates little mist), clean the ceramic disc as indicated above. For stubborn oil build up, use sanitary alcohol on a cotton bud if required.

When cleaning, always take extra care to ensure water does not enter DC Jack power port. Allow the unit to dry thoroughly as advised below if water accidentally enters the electrical port.

**Accidental Leakage:** In the event of the aroma diffuser being knocked over during use, please follow the steps below to avoid malfunction.

- Unplug the diffuser from the mains and remove the cover carefully.
- Pour out any remaining water from the tank.
- Shake the diffuser gently to drain any water from inside, then leave for 24 hours for the diffuser to dry thoroughly in a well-ventilated area.

# F - TROUBLESHOOTING

Problem	Possible Cause	Solution
No Mist or mist volume significantly reduced	Power supply is not connected	Plug in the power adaptor and press the MIST button on the base.
	Water is lower than the water level sensor	Refill the tank with ordinary tap water. Take care not to fill past the max water level line
	Water is exceeding the max water level line	Carefully pour out excess water in the drainage direction shown by the arrow
	There may be a build-up of oil on the ceramic disc	Clean the ceramic disc with water and a clean cloth
	Mist outlet is blocked	Clean the mist outlet by thoroughly cleaning the inside of the cover with clean water
Unit will not switch on	There is an insufficient amount of water in the tank	Fill the water tank with water up to the max water level line. Do not over fill
	The power cable may not be connected properly	Disconnect the cable and try connecting properly
Water is leaking from the product	The cover is not positioned correctly	Remove the covers and replace correctly allowing mist to release correctly
	The unit has been tipped or knocked over	Follow the accidental leakage instructions
	The temperature is low or there is high humidity	Under these conditions the mist can sometimes condense into water droplets
	Water moisture has built up inside the cover	Remove the inner cover and dry off excess water from the inside of the cover
Remote control is not working	The battery may have stopped working	Please unscrew the battery section on the back of the remote and change the battery (screw driver not included)

The intensity and amount of mist may vary, but this is not unusual and should not be considered as a fault. Factors that may affect this include water type, humidity, temperature, air currents etc.

## G - WARRANTY

This product carries a 12-month warranty for proper use in accordance with this manual against any manufacturing defects. Accidental damage is not covered under the warranty.

The warranty period is 12 months from the date of purchase. In case of any problems arising during the warranty period, please contact your retailer for maintenance or claims. Proof of purchase will be required, so it is vital that you keep your receipt of purchase with this manual safely.

Corrosive oils such as Citronella may cause damage to the unit if left in the water tank. This type of damage is not covered under the warranty. This Aroma Diffuser must be cleaned after each use.



**IMPORTANT!**

MADE BY ZEN® Ultrasonic Aroma Diffusers comply with the WEEE Directive (Waste from Electrical and Electronic Equipment Directive) 2012/19/EU.

Electrical equipment is a large source of waste and if not properly recycled could have damaging effects on the environment, whereas if it is recycled, the resources could be used again.

Electronic waste needs to be separated from other waste to be recycled properly. When the Chi Aroma Diffuser reaches the end of its working life, please deposit at an appropriate collection point for recycling of electrical products. You can also recycle used electronics at Household Waste Recycling Centres.

Caring for our planet is important to us, so please help us by disposing of the Chi correctly. Thank you.



MADE BY ZEN®

MADEBYZEN.COM