

SunTouch
Floor Warming Systems

Do It Yourself FLOOR WARMING

Series D12

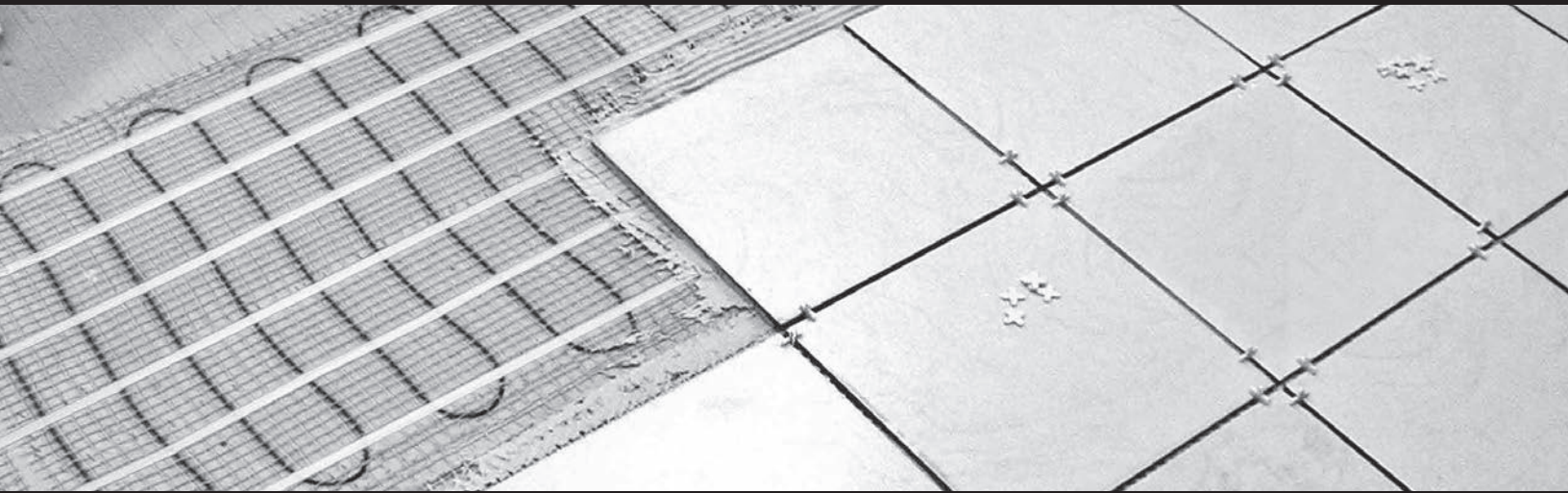

INSTALLATION MANUAL

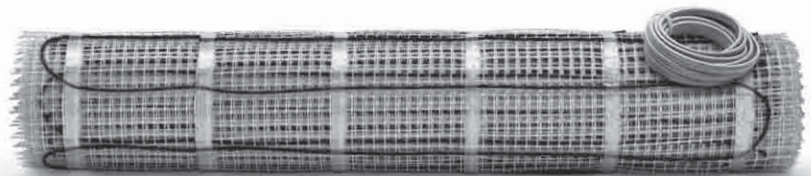

866-558-3369
www.WarmYourFloor.com



Please be aware local codes may require this product and/or the thermostatic control to be installed or connected by an electrician. Please leave this manual with the end user.

You are required to thoroughly read all installation instructions and product safety information before beginning the installation of this product. FAILURE TO COMPLY WITH PROPER INSTALLATION AND MAINTENANCE INSTRUCTIONS COULD RESULT IN PROPERTY DAMAGE, PERSONAL INJURY AND/OR DEATH. Watts Radiant is not responsible for damages resulting from improper installation and/or maintenance.

Welcome to SunTouch®!

SunTouch floor heating mats are a simple way to heat an indoor space. This instruction manual is provided as a guide to installing SunTouch Mats, including design considerations, installation steps, limitations, precautions, and floor covering guidelines.

Specifications for SunTouch Mat:

SunTouch Mat is a complete heating mat consisting of a series heating wire and a power lead for connection to the electric power supply. **The heating wire length cannot be cut to fit.**

Controls: SunTouch Mats must be controlled by a SunStat® floor sensing thermostat.

Voltage: 120 VAC, 240 VAC, 1-phase (see Table 2)

Watts: 12 W/sqft (41 Btu/h/sqft)

Maximum circuit load: 15 A

Maximum circuit overload protection: 20 A breaker

GFCl: (Ground Fault Circuit Interrupter) required for each circuit (included in the SunStat control)

Listing: UL Listed for U.S. and Canada under UL 1693 and CAN/CSA C22.2 No. 130-03, File No. E185866

Application: Type (X) (See UL Name Plate Label on product)

For indoor floor heating application only. Only embedded in polymer modified cement based mortar. UL Listed to U.S. Standards only for installation into a shower area. (See 4.10 for details).

Minimum bend radius: 1 inch

Maximum exposure temperature: (Continuous and storage) 194°F (90°C)

Minimum installation temperature: 50°F (10°C)

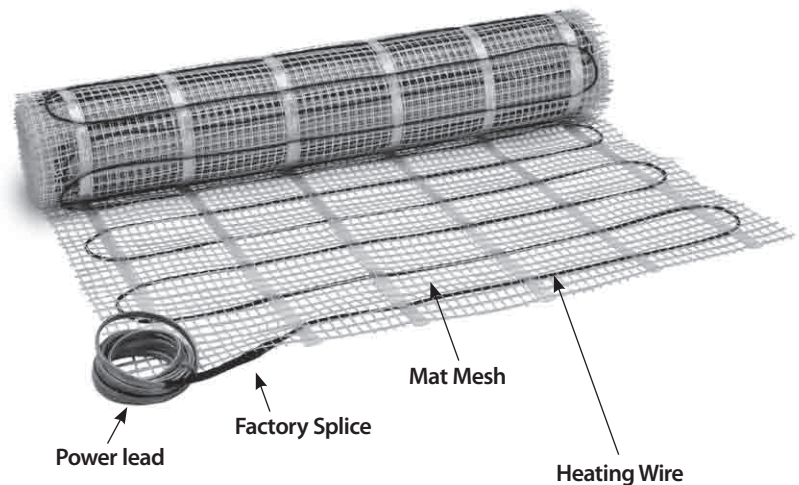

Skill Level

Installation must be performed by qualified persons, in accordance with local codes, ANSI/NFPA 70 (NEC Article 424) and CEC Part 1 Section 62 where applicable.

Prior to installation please consult the local codes in order to understand what is acceptable. To the extent this information is not consistent with local codes, the local codes should be followed. However, electrical wiring is required from a circuit breaker or other electrical circuit to the control. It is recommended that an electrician perform these installation steps. Please be aware local codes may require this product and/or the control to be installed by an electrician.

Expected floor temperature

Heating performance is never guaranteed. SunTouch Mat is designed to deliver 12 W/sq.ft. The floor temperature attainable is dependent on how well the floor is insulated, the temperature of the floor before start up, and the overall thermal drain of the floor mass. Insulation is required for best performance. Refer to Phase 5 for important design considerations.

Table of Contents

Phase 1 - Designing the System	pg 4
Phase 2 - Preparations	pg 5
Phase 3 - Electrical Rough-in	pg 8
Phase 4 - Mat Installation.....	pg 9
Phase 5 - Floor Coverings	pg 13
Phase 6 - Control Installation	pg 15
Appendices	pg 16
Control Wiring	pg 19
Connections	pg 20
Troubleshooting	pg 21
Warranty	pg 22

Table 1

CAUTIONS!

READ BEFORE INSTALLING SUNTOUCH MAT

You are required to thoroughly read all installation instructions and product safety information before beginning the installation of this product. **FAILURE TO COMPLY WITH PROPER INSTALLATION INSTRUCTIONS COULD RESULT IN PROPERTY DAMAGE, PERSONAL INJURY and/or DEATH.** Local building or plumbing codes may require modifications to the information provided. You are required to consult the local building and plumbing codes prior to installation. If this information is not consistent with local building or plumbing codes, the local codes should be followed.

Watts Radiant is not responsible for damages resulting from improper installation and/or maintenance.

NOTE: Electrical wiring is required. Watts Radiant recommends consulting with a licensed electrician prior to installation. Specifically, it is recommended that an electrician perform all electrical wiring from the circuit breaker or other electrical circuit to the control. Please be aware that local codes may require that this product is installed by a licensed professional.

NEVER install SunTouch Mat under carpet, wood, vinyl, or other non-masonry flooring without embedding it in thin-set, thick-set, or self-leveling mortar.

NEVER install SunTouch Mat in adhesives or glues intended for vinyl tile or other laminate flooring, or in pre-mix mortars. It must be embedded in polymer-modified, cement based mortar.

NEVER cut the heating wire. Doing so will cause dangerous overheating and will void the warranty. The power lead may be cut shorter if necessary, but never remove completely from the heating wire.

NEVER bang a trowel or other tool on the heating wire. Be careful not to nick, cut, or pinch the wire causing it to be damaged.

NEVER use nails, staples, or similar to fasten the heating wire to the floor.

NEVER attempt to repair a damaged heating wire, splice, or power lead using unauthorized parts. Use only factory authorized repair parts and methods.

NEVER splice one mat heating wire to another mat heating wire to make a longer mat. Multiple mat power leads must be connected in parallel in a junction box or to the thermostat.

NEVER install one mat on top of another or overlap the heating wire on itself. This will cause dangerous overheating.

NEVER forget to install the floor sensor included with the thermostat.

NEVER install SunTouch Mat in any walls, or over walls or partitions that extend to the ceiling.

NEVER install mats under cabinets or other built-ins having no floor clearance, or in small closets. Excessive heat will build up in these confined spaces, and the mat can be damaged by fasteners (nails, screws, etc.) used to install built-ins.

NEVER remove the nameplate label from the power leads. Make sure it is viewable for inspection later.

NEVER extend the heating wire beyond the room or area in which it originates.

NEVER allow a power lead or sensor wire to cross over or under a heating cable. Damage could result.

ALWAYS completely embed the heating wire and factory splices in the floor mortar.

ALWAYS maintain a minimum of 2" spacing between heating wires.

ALWAYS pay close attention to voltage and amperage requirements of the breaker, the thermostat, and the Mat. For instance, do not supply 240 VAC power to 120 VAC Mat as damage will result.

ALWAYS make sure all electrical work is done by qualified persons in accordance with local building and electrical codes, Section 62 of the Canadian Electrical Code (CEC) Part I, and the National Electrical Code (NEC), especially Article 424.

ALWAYS use copper only as supply conductors to the thermostat. Do not use aluminum.

ALWAYS seek help if a problem arises. If ever in doubt about the correct installation procedure to follow, or if the product appears to be damaged, the factory must be called before proceeding with the installation.

Phase 1: Designing the System

SunTouch Mat should be installed in all interior floor areas intending to be warmed. It cannot be used for exterior applications, snow melting, in or on walls, or in ceilings. In many applications it can be used to heat the room but an accurate heat-loss calculation must be made to determine if enough heat will be provided to match the heat loss.

STEP 1.1

Make a sketch of the room and measure the overall room size. Measurement should be made from wall-to-wall and include size and location of cabinets, tub, toilets, etc. Determine the total square footage of floor area to be warmed by subtracting out the area associated with the built-ins. Keep in mind the following:

- Heat will not radiate beyond about 1-1/2" on either side of the heating wire, therefore consistent coverage is important.
- **Do** install heating wire within about 1-1/2" to 2" from a counter or vanity in the kick-space to ensure warmth in this area.
- **Do not** install the heating wire underneath cabinets or fixtures having no floor clearance or inside a wall. Excessive heat will build up and cause damage.
- **Do not** run the heating wire into small closets or other confined areas where excessive heat will build up.
- **Do not** install the heating wires closer than 6" from toilet rings to avoid possible melting of wax rings.
- **Do not** directly cross expansion joints.
- **Do not** place the heating wire any closer than 4" from other items such as forced air ducting or potable piping to avoid overheating them.
- SunTouch Mat must be laid in a manner to prevent surface obstructions being placed directly over the mat location. Failure to do so will result in capturing heat and may allow potential damage from mounting brackets, bolts, or similar penetrations associated with pedestals, support columns, walls, or similar.
- Install the heating wires 4" to 6" away from the perimeter walls of the room. It may be placed closer, but is unnecessary since most people do not stand this close to the wall. Make sure the heating wire will not be located underneath finish trim.

Gross Room Area: 8 x 5 = 40 sf

Built-in Areas

Sink and Toilet: 2 x 5 = 10 sf

Bath Tub: 2.5 x 5 = 12.5 sf

Total Heated Area: 40 - (10 + 12.5) = 17.5 sf

Mat Coverage: 17.5 x 0.90 = 15.75 sf

Chosen Mat Size: 15 sf.

- The heating wire and factory splices must be completely embedded in the thin-set. Only the power lead may exit the thin-set and enter the wall. Pull power leads through UL Listed conduit to a UL Listed junction box or the control box.

STEP 1.2

Multiply the heated area square footage calculated in Step 1.1 by 0.90 to allow 4" to 6" spacing around the edges of the floor area. Use this resulting square footage to select the appropriate mats from Table 2 on page 5.

Remember:

- **Do not** exceed 15 amps at 120 VAC (1800 watts) or 15 amps (3600 watts) at 240 VAC through a single SunStat.
- Select either 120 VAC or 240 VAC depending on the power available. **DO NOT** mix voltages on the same SunStat if more than one mat is to be installed to cover an area.
- Load no more than 12 amps on a 15-amp circuit breaker, or 15 amps on a 20-amp circuit breaker.
- See the Wiring Diagrams in Appendix for further information.

If the exact size of product calculated is not found in the selection Table 2 on page 5, it may be necessary to adjust the warming area(s) or select the next smaller size. **Remember, the heating wire must never be cut shorter to fit, and must be completely embedded in thin-set, thick-set, or self-leveling concrete. Failure to do so may result in damage to the product. Do not select a product larger than necessary.**

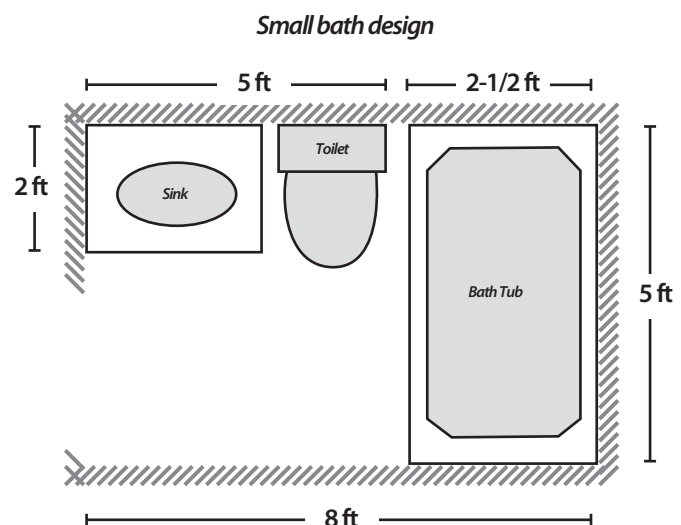

STEP 1.3

Make sure proper subfloor materials are selected in accordance with the construction and floor covering requirements. Use of a moisture barrier, an anti-fracture membrane, backerboard, or other materials are recommended when installing tile or other stone floor covering.

STEP 1.4

Pay careful attention to the total amps when selecting multiple mats to make sure the controls, circuit breaker panel, and all wiring have the proper capacity. Design circuit protection and wiring to handle 125% of total amp load.

Phase 2: Preparations

Before installing SunTouch Mat, make sure to fully inspect the products and carefully plan the site.

Items Needed

Materials:

- SunStat thermostat control with floor sensor. The SunStat is listed separately from the Mat.
- 20-amp circuit breaker
- UL Listed electrical box (extra deep) for the control; single-gang (not a gangable type) for one or two mats or 4"-square deep box with a single-gang "mud ring" cover
- 4" junction box with a cover (if needed)
- Flexible or rigid UL Listed conduit (for new construction)
- 12-gauge or 14-gauge electrical wiring cable (consult local code)
- Wire nuts if using an additional junction box
- Nail plate

Tools:

- Digital multi-meter for ohms testing; must read up to 20,000 ohms to measure sensor
- Drill with 1/2" & 3/4" bits
- Hammer and chisel
- Wire strippers
- Phillips screwdriver
- Fish tape
- Hole saw
- Floor covering installation tools

Table 2 (Mat sizes)**120 VAC**

Mat Square Footage	Mat Size (W x L)	Model Number	Amp Draw	Ohms
10	30" x 4'	12000430	1.0	114-141
15	30" x 6'	12000630	1.5	74-92
20	30" x 8'	12000830	2.0	57-71
25	30" x 10'	12001030	2.5	44-54
30	30" x 12'	12001230	3.0	34-43
35	30" x 14'	12001430	3.5	29-37
40	30" x 16'	12001630	4.0	25-32
45	30" x 18'	12001830	4.5	22-28
50	30" x 20'	12002030	5.0	20-26
60	30" x 24'	12002430	6.0	17-22
70	30" x 28'	12002830	7.0	14-18
80	30" x 32'	12003230	8.0	12-16

240 VAC

Mat Square Footage	Mat Size (W x L)	Model Number	Amp Draw	Ohms
20	30" x 8'	24000830	1.0	219-269
30	30" x 12'	24001230	1.5	155-190
40	30" x 16'	24001630	2.0	115-141
50	30" x 20'	24002030	2.5	88-108
60	30" x 24'	24002430	3.0	68-85
70	30" x 28'	24002830	3.5	58-72
80	30" x 32'	24003230	4.0	51-64
90	30" x 36'	24003630	4.5	45-56
100	30" x 40'	24004030	5.0	41-51
120	30" x 48'	24004830	6.0	34-42
140	30" x 56'	24005630	7.0	29-36
160	30" x 64'	24006430	8.0	25-32

It is important to select the proper sized mat for the given area. Mat cannot be cut shorter in order to fit a given area. Doing so will damage the heating wire and will prevent the system from working.

INSPECT MAT, CONTROL, and SENSOR



WARNING: To prevent the risk of personal injury and/or death, make sure power is not applied to the product until it is fully installed and ready for final testing. All work must be done with power turned off to the circuit being worked on.

STEP 2.1

Remove the Mat, SunStat control, and SunStat sensor from their packages. Inspect them for any visible damage and verify everything is the correct size and type according to the plan and the order. Do not attempt to install a damaged product.

STEP 2.2

Record the product information in **Table 4**. Give this information to the homeowner to keep in a safe place.

The mat model number, serial number, voltage, and resistance range are shown on a nameplate label attached to the power leads, as well as the marking "(x)-FOR INDOOR FLOOR HEATING APPLICATIONS".

Do not remove this nameplate label. The electrical inspector will need to see this.

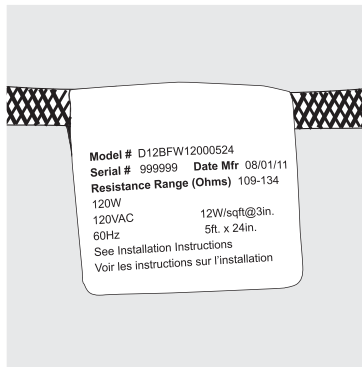

Record the information from the nameplate label into the Mat and Sensor Resistance Log. Leave the nameplate label attached to the power leads for later inspection.

STEP 2.3

Use a digital multi-meter set to the 200Ω or 2000Ω (2kΩ) range to measure the resistance between the conductors of the mat power leads. Record these resistances in **Table 4** under "Out of the box before installation".

The resistance should measure within the resistance range on the nameplate label. If it is a little low, it may be due to low air temperatures or meter calibration. Consult the factory if in doubt.

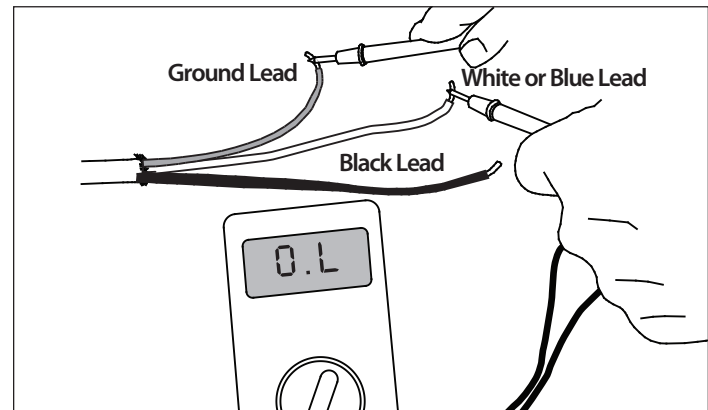
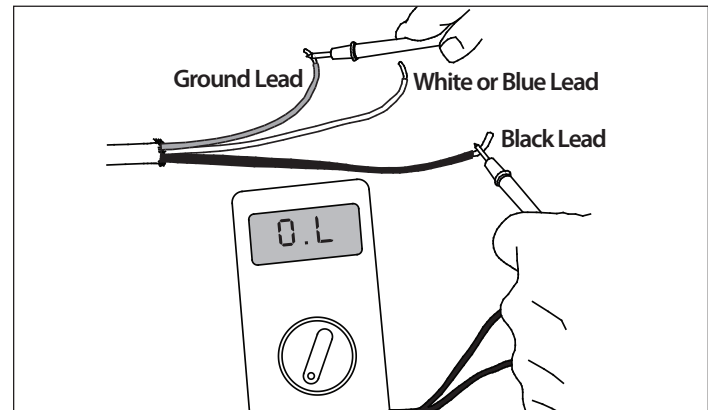
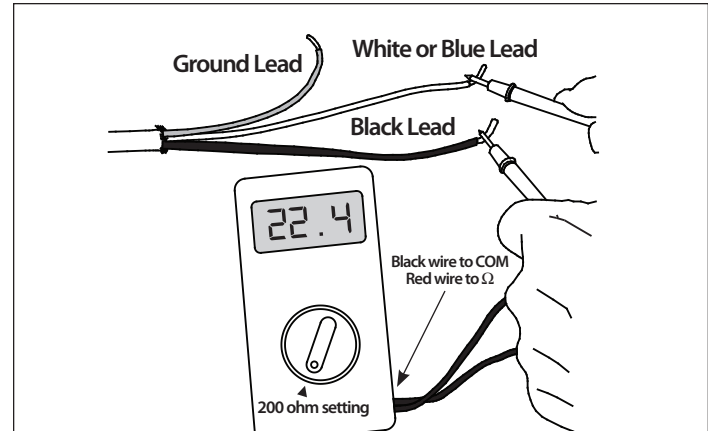

Press the test lead tips to the Black and White (or Blue for 240 VAC) power lead wires. This reading should correspond to the factory resistance range on the nameplate label attached to the Power lead.

Readings between the Black and Ground and the White (or Blue for 240 VAC) and Ground power lead wires should measure "open", or "0.L", or the same as displayed when the test leads are not touching anything.

Measure the resistance between either of the white or black leads and ground lead. This measurement should be “open”, usually indicated by an “OL” or a “1”. This is the same as displayed when the test leads are not touching anything.

If there is any change in the reading, record this information and contact the factory before continuing. This could indicate damage, test lead problems, or a number of other issues. Try “pinning” the test leads to the cable lead wires against a hard non-metal surface if the readings continue to fluctuate.

Change the meter to the 20,000 ohms (20 k Ω) range. Measure between the lead wires of the SunStat sensor. This resistance varies according to the temperature sensed. **Table 3** provides approximate resistance-to-temperature values for reference.

Table 3 (floor sensor resistance values)

Temperature	Typical Values
55°F (13°C)	17,000 ohms
65°F (18°C)	13,000 ohms
75°F (24°C)	10,000 ohms
85°F (29°C)	8,000 ohms

Table 4 - Mat & Sensor Resistance Log

	Mat 1	Mat 2	Mat 3
Mat serial number			
Mat model number			
Mat voltage			
Mat resistance range			
Sensor			
OUT OF THE BOX BEFORE INSTALLATION			
Mat white to black			
Mat white to ground			
Mat black to ground			
Sensor			
AFTER MAT IS SECURED IN PLACE			
Mat white to black			
Mat white to ground			
Mat black to ground			
Sensor			
AFTER FLOOR COVERINGS ARE INSTALLED			
Mat white to black			
Mat white to ground			
Mat black to ground			
Sensor			
Retain this log to retain the warranty! Do not discard!			

Phase 3: Electrical Rough-in

STEP 3.1: Circuit Breaker (Overcurrent Protection)

SunTouch Mat(s) must be protected against overload by a circuit breaker. GFCI type (ground fault circuit interrupter) or AFCI type (arc-fault circuit interrupter) breakers may be used if desired, but are not necessary.

The rating of the breaker (see Table 5) is determined by the amp draw of the heating mats (see Table 2 or the Nameplate Label). If multiple mats are to be controlled by one SunStat, total their amp draws. If this total exceeds 15 amps, an additional breaker and control will be required. The total amps on each breaker cannot exceed 15 amps. Do not use breakers rated over 20 amps.

Table 5

Circuit Breakers and Supply Wire					
Mat(s)		Supply Wire	Breaker		
VAC	total amps	(AWG)*	qty	type**	rating
120	up to 12 amps	14	1	SP	15 or 20 A
120	up to 15 amps	12	1	SP	20 A
240	up to 12 amps	14	1	DP	15 or 20 A
240	up to 15 amps	12	1	DP	20 A

* Recommended only. Follow local codes for wire gauge size.

** SP= single-pole, DP=double-pole

It may be possible to tap into an existing circuit as long as there is adequate capacity for the mat(s) and any additional appliance, such as a hair dryer or vacuum cleaner. Avoid circuits which have lighting, motors, exhaust fans, or hot tub pumps due to possible interference.

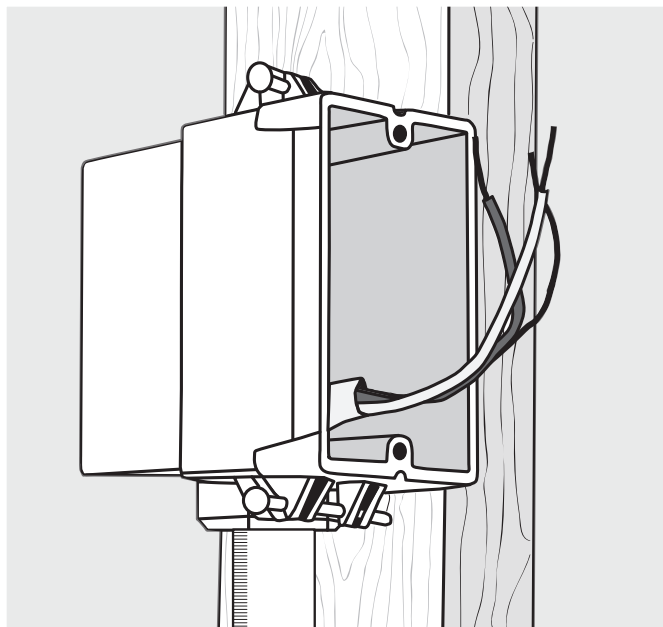

Install an extra-deep single-gang box if connecting one or two cables to the control. Use a 4"-square deep box with a single-gang mud ring cover if connecting three cables, because the extra room is needed for the wire, wire nuts, and control.

STEP 3.2: Install Electrical Boxes

SunStat Thermostat:

Install an extra-deep electrical box for the SunStat thermostat. Follow the instructions included with the SunStat for complete information on location and wiring.

Junction Boxes:

If a mat is to be located so its Power lead is not long enough to reach the SunStat directly, a junction box must be installed. Do not attempt to make a connection to other wiring without a junction box. Use a standard junction box with a cover, mounting it below the subfloor, in the attic, in the wall, or in another location easily accessible after all coverings are complete. If the SunStat sensor wire is not long enough to reach the SunStat directly, it may be extended. A junction box may be required by local code to make this connection. Follow the installation instructions included with the SunStat for details.

For construction with an existing wall or where the wall is covered, cut the necessary openings to mount the electrical boxes listed above. Wait to install the boxes until all wiring is fed into these locations to make it easier to pull the wire.



WARNING: To prevent the risk of personal injury and/or death, do not perform any electrical work unless qualified to do so. Work should be done with great care and with power turned off to the circuit being worked on. Follow all local building and electrical codes.

STEP 3.3: Bottom Plate Work

Drill or chisel holes at the bottom plate as indicated. One hole is for routing the power lead conduit and the other is for the thermostat sensor. These holes should be directly below the electrical box(es).

STEP 3.4: Install Power Lead Conduit and Thermostat Sensor

Power Lead Conduit:

The shielded power lead can be installed with or without electrical conduit (recommended for added protection against nails or screws) depending on code requirements. Remove one of the knock-outs in the electrical box to route the power lead. If electrical conduit is not required by code, install a wire collar to secure the power leads where they enter the box. If conduit is required by code, install 1/2" (minimum) conduit from the bottom plate up to the electrical box. For multiple power leads (multiple mats) install 3/4" conduit.

Thermostat Sensor:

The SunStat sensor can be installed with or without electrical conduit depending on code requirements. Conduit is recommended for added protection against nails or screws. Do not place the sensor in the same conduit as the power leads to avoid possible interference. Open a separate knock-out in the bottom of the thermostat box. Feed the sensor (and conduit, if used) through the knock-out, down through the cut-out in the bottom plate, and out into the floor where the heating mat will be installed. If the sensor wire needs to be secured to the wall stud, wait until after the mat and sensor are completely installed on the floor.

STEP 3.5: Rough-in Wiring

Install appropriate 12 or 14 AWG electrical wire from the circuit breaker or branch circuit source to the SunStat electrical box following all codes, see Table 5.

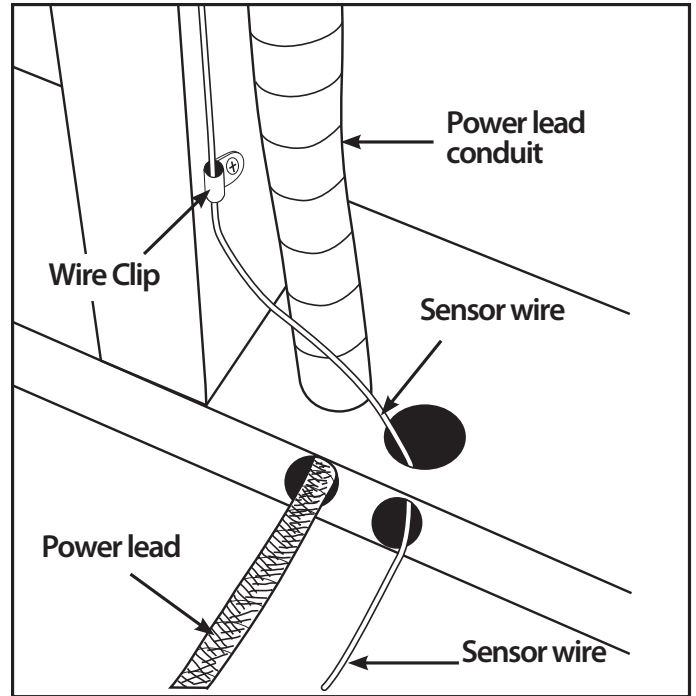

Conduit enclosing power lead.

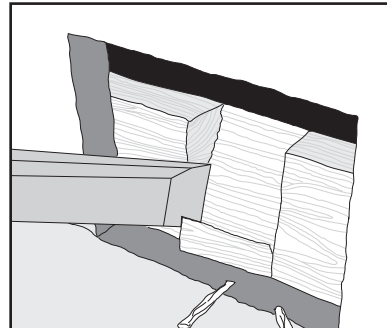

If going in to an existing wall, cut out dry wall and chisel out bottom plate to route wires to control.

Phase 4: Mat Installation

STEP 4.1: Floor Cleaning

The floor must be completely swept of all debris including all nails, dirt, wood, and other construction debris. Make absolutely sure there are no objects on the floor which might damage the mat wire.

Wet mop the floor at least twice to ensure there is no dirt or dust. This will allow proper bonding of the mortar and proper stick of the double-sided tape.

STEP 4.2: Material

Make sure all of the correct materials have been purchased. A general list of materials is found at the beginning of this manual.

Verify the amount of mat supplied is the proper size for the area to be heated before beginning the installation. Verify thermostat location.

**STEP 4.3:
Position the Power Leads**

Carefully cut the tie binding the power lead coil. Do not nick the braid covering the power lead.

Place the mat on the floor to ensure the power lead will reach the SunStat electrical box or junction box location.

If the power lead will need to cross a long distance to reach the control location, it may be possible to cut the mat mesh and pull loose the length of heating wire needed.

Make sure the power lead factory splice is to be completely flat and in the floor mortar, not in the wall.

**STEP 4.4:
Test Fit the Mat**

Roll out the mat, flipping it as needed to cover the intended area. This is very important to ensure proper fit before proceeding. If there is too much mat for the area it cannot be cut shorter and heating wire cannot be routed into a wall, under baseboards, or other similar areas. All heating wire must be embedded in the floor mortar.

CAUTION: Do not cut the heating wire to make it fit the area. Doing so will cause dangerous overheating and will void the warranty.

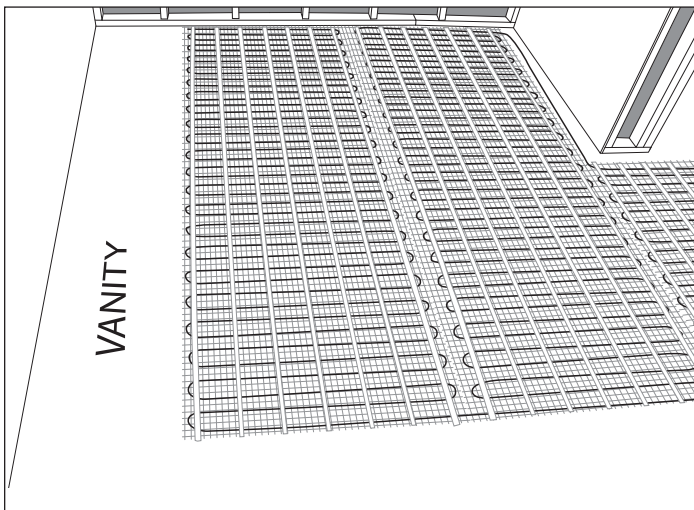

Install the mat approximately 4"-6" away from walls, showers, tubs, toilets, drains, etc. Install in-line with vanity and counter areas. Install roughly 18"-20" from back wall in toilet area.

DO NOT leave gaps between the mats. The heat will conduct only about 1-1/2" from the heating wire. Mat should be installed continuously across the floor. Never install mats in a fashion causing the heating wires to be any closer than 2" from each other or to overlap.

To warm the maximum amount of floor area, it may be necessary to make the mat(s) fit odd-shaped spaces, fit into corners, and work around angles and built-ins. See Table 6 for technique examples and the Appendix for full layouts, additional techniques, and cautions.

**TABLE 6:
MAT TURNS AND "FILL-IN" TECHNIQUES**

This table contains some of the common turns and techniques used to layout around corners, angles, and built-ins.

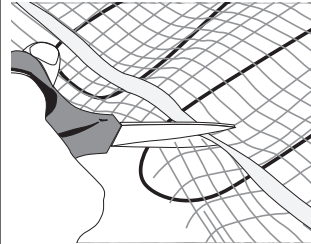

Carefully cut the orange mesh to make turns. Never cut, nick, or otherwise damage the heating wire.

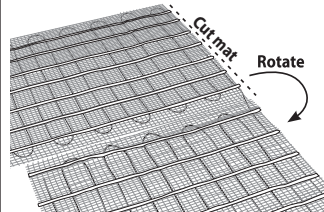
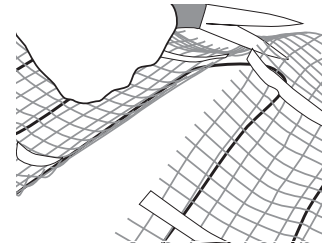

180° or Back-to-Back Turn.

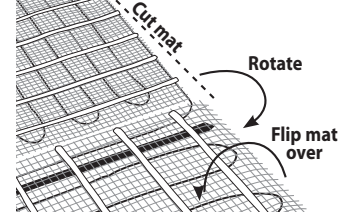

90° or Flip Turn.

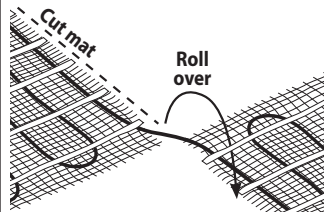

Roll-over Turn.

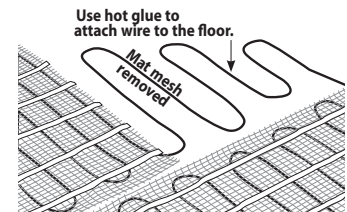

Fill-in Technique.

Installing in front of cabinets and toilets:

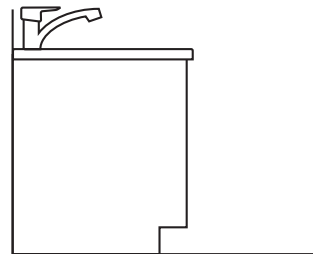

Install mat right up to the face of the cabinet as shown above.



Mat can be installed under tile to within 4"-6" from the wax ring, and can slightly underlay the foot of the toilet if need be (approximately 20" from wall).

STEP 4.5: Secure the Mat to the Floor

After test-fitting the mat and deciding what technique will be used to help fill any odd spaces, carefully cut the mesh where needed.

Lay the mat down flat. Ensure it fits well and has no folds or large ripples.

IMPORTANT: Securing the mat as flat as possible will help make a smooth surface for spreading mortar.

Begin removing the liner from the double-sided tape along one mat edge and press the tape down, ensuring the mat lays flat.

Remove the liner from the double-sided tape along the other mat edge and press the tape down. Pull on the mat as needed to ensure it is flat as possible but be careful not to pull the tape loose.

If an area of mesh does not lay flat enough, use a length of the double-sided tape supplied in the Installation Kit, hot-glue, or pneumatically applied staples to help. This may be necessary at the ends of the mat. If staples are used, 3/8" x 1/4" chisel type are recommended. Do not staple closer than 1/4" (7 mm) from the heating wire. Be very careful not to damage the heating wire.

DO NOT staple or apply tape over the heating wire. Damage can result.

DO NOT use nails, duct tape, other types of tape, or other unapproved fasteners to hold the heating wire or mesh in place. Damage can result.

STEP 4.6

Use a digital multi-meter to measure the resistance between the conductors of the power leads again. Record these resistances in **Table 4** under "After mat is secured in place".

STEP 4.7

Feed the power leads through the conduit to the control electrical box, leaving at least 6"-8" of free power lead. Chisel a slot in the floor to recess the factory splice level with the heating wire. Secure the factory splice with hot glue so it cannot be pulled into the conduit.

It may be necessary to use a metal nail plate to protect the power lead and sensor wire as they transition into the wall. This will help prevent nail penetrations from drywall and baseboards trim.

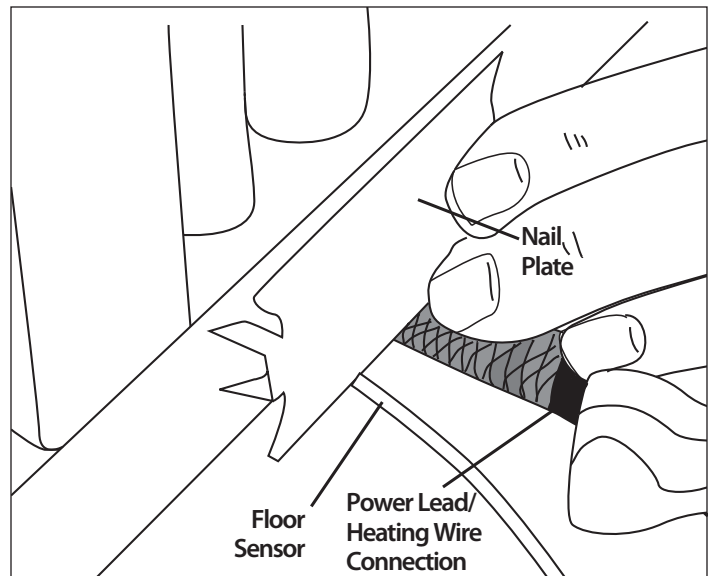
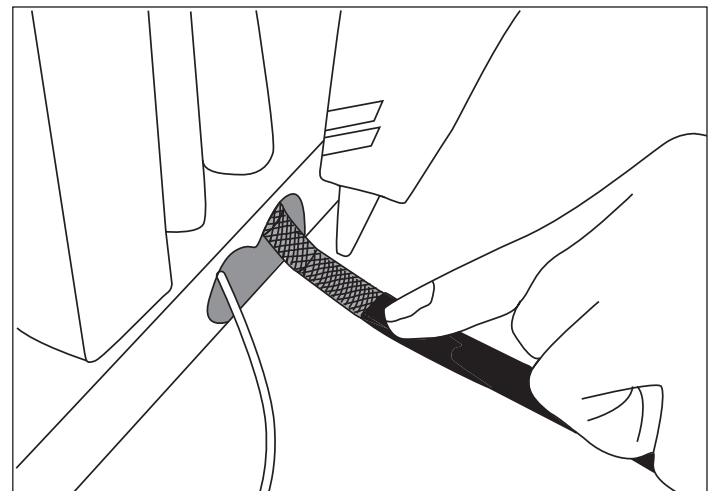
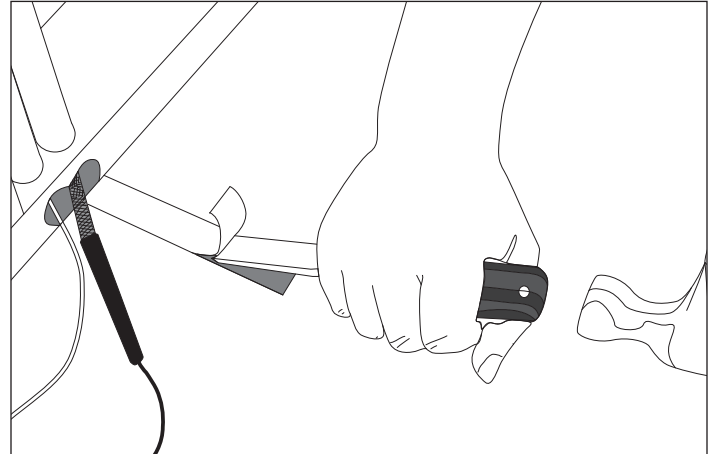

Chisel a path for the power lead and factory splice. Use hot glue to secure to the floor. Place a metal nail plate over the transition point to protect the power lead and sensor wire.

STEP 4.8

Feed the sensor wire through the sensor conduit, leaving at least 6"-8" of free lead length at the control electrical box. Weave the sensor at least 1' into the mat area, halfway between the heating wires, and secure it using hot glue. Do not cross the heating wires. It may be necessary to chisel a small section of the subfloor to accommodate the sensor, depending on the thin-set thickness being used.

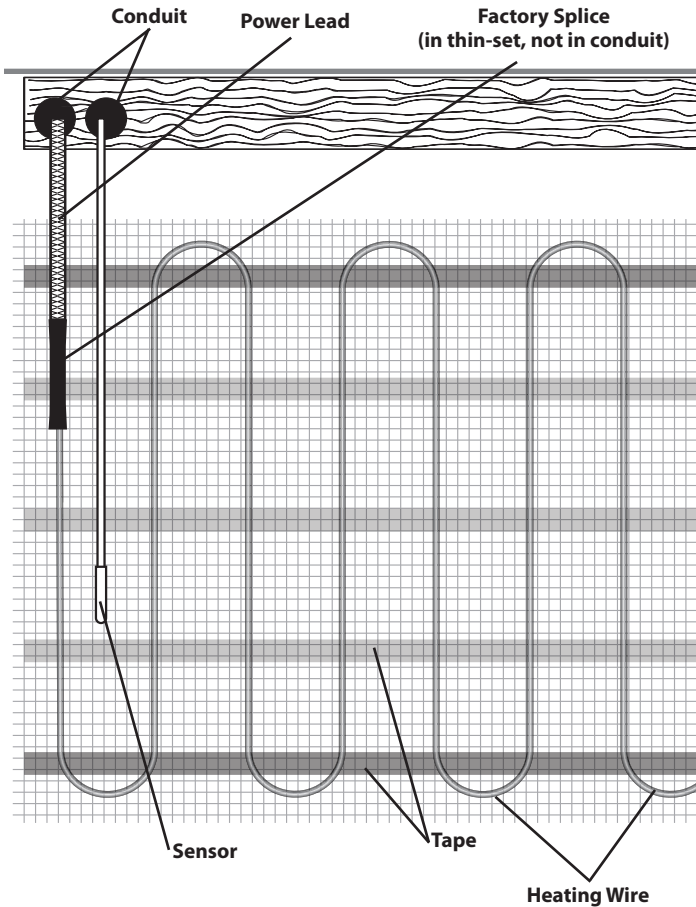

Top-Down view of Mat and the sensor entering wall.

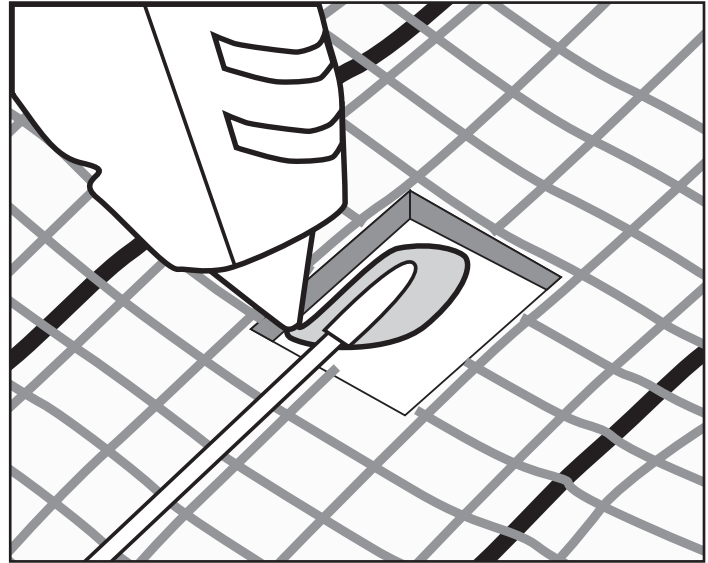
**STEP 4.9:
Shower Application**

Note: Acceptance of this application must be verified by the local inspector or authority having jurisdiction (AHJ). UL Listed to U.S. Standards only for this application.

1. Refer to diagrams in the Appendix, especially page 17.
2. Never install SunTouch Mat in shower walls (or any other wall).
3. Never make a field splice to mats installed in a shower.
4. Use the double-sided tape or hot-glue to secure the mat. Do not use staples or anything that will damage any waterproofing membrane.
5. Make a 1" wide notch in the curb to embed the heating wire. Ensure the wire is not pinched or bent sharply. Do not run the heating wire through a non-masonry curb, causing it to overheat.

6. Embed mats in mortar and install only under tile, stone, brick, or other masonry surface, per this instruction manual.

Locate power lead and factory connection to heating wire at least 1' outside the shower area.

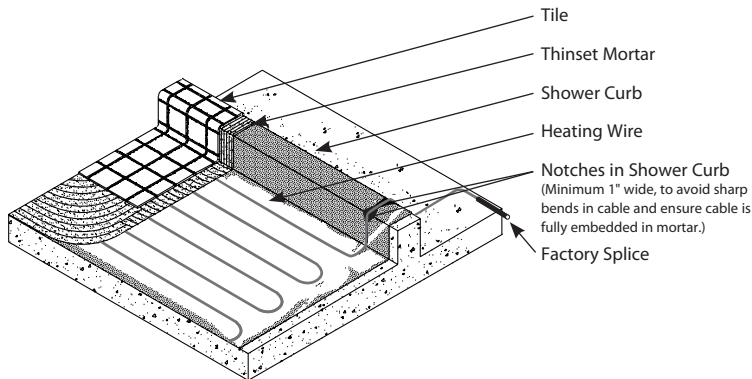

7. Never begin the mat in a shower. The connection between the power lead and the heating wire must be fully embedded in mortar and located at least 1' (304.8 mm) away from shower openings and other areas normally exposed to water.
8. Mat controls must be located at least 4' away from shower openings. Controls cannot be exposed to water or touched by a person while in the shower area.
9. All grout seams should be sealed after the mortar and grout has completely cured.
10. As an option, consider installing a dedicated mat in the shower area, separate from the rest of the floor. This will increase control options, allowing less floor to be warmed when the shower is not required. It will also allow for better isolation of the shower area in the off-chance a problem occurs.

STEP 4.10

Take photographs of the mat installation. This can be very useful later during remodel work to help avoid possible wire damage. Keep the photos with this installation manual and provide to end user upon completion.

Phase 5: Floor Coverings

It is recommended to consult with professional flooring installers to make sure proper materials are used and proper installation techniques are followed. Please note, this installation manual is not a structural or a floor covering installation manual and is intended only for general guidance as it applies to the SunTouch Mat product.

When installing tile or stone, the Tile Council of North America (TCNA) guidelines, National Tile Contractors Association (NTCA), or ANSI specifications should be followed as a minimum standard.

A polymer-modified thin-set cement-based mortar and grout is recommended instead of water-based multi-purpose materials when installing a radiant product.

Do not use solvent based adhesives or pre-mix mortars because they are not as heat resistant.

Select the proper size trowel for the installation of tile or stone. We recommend a minimum 3/8" x 1/4" trowel. This trowel works well for most ceramic tile. A thicker thin-set can be used if required. Select the thin-set thickness in accordance with the floor covering requirements.

For additional information on tile installation, please contact TCNA at 864-646-8453 or visit their web site at www.tileusa.com.

When installing floor coverings other than tile or stone, follow industry and/or manufacturer's recommendations. Ensure the mat is first covered with a layer of self-leveling cement based mortar, letting it cure fully before applying any surface underlayment, floating wood or laminate flooring, carpet, etc. The combined R-values of all floor coverings over the mat should not exceed R-3. Higher R-values will diminish performance. Consult the floor covering manufacturer to verify compatibility with radiant electric heat. Also, make sure nails, screws, or other fasteners do not penetrate the floor in the mat area. The wire can easily be damaged by fasteners penetrating the floor.

All floor coverings must be in direct contact with the cement-based mortar encasing the mat. Do not elevate the floor above the mortar mass. Do not install 2" x 4" wooden nailers (sleepers) on top of a slab for the purpose of attaching hardwood. Any air gap between the heating mat and the finished floor covering will drastically reduce the overall output of the heated floor.

Care should be taken when laying area rugs, throw rugs, and other surface products on the floor. Most products are okay to use, but if in doubt, consult the product manufacturer for compatibility. Do not use rubber backed products that may degrade or very heavy rugs that will trap heat. Be careful not to place a rug over the area where the sensor tip was placed, causing false thermostat readings.

When placing furniture make sure an air clearance of at least 1-1/2" is available. Furniture able to trap heat can damage the heating system, the flooring, and the furniture over time.

Use a digital multi-meter to measure the resistance between the conductors of the power leads again. Record these resistances in Table 4 under "After floor coverings are installed".

Type of Construction

Mortar Applications:

Thin-set and thick-set (self-leveling) mortar applications are illustrated to the right.

- a. If a backer board or plywood sheeting is used to strengthen the floor, or if the mat will be placed directly onto the slab, install mat in the thin-set mortar bond coat above these materials.
- b. If a thicker mortar bed, or self-leveling concrete, is used to strengthen the floor, mat can be installed in either the mortar bed (dry-set) or in the mortar bond coat directly below the tile or stone.

SunTouch Mat is generally installed above the self-leveling mortar in a thin-set bond coat. Use plastic lath instead of the typical metal lath when installing in a self-leveling layer.

Self-leveling Mortar Applications:

These are appropriate applications if installing engineered wood, vinyl, laminate, or carpet floor coverings. Attach the mat to the subfloor or slab, then pour self-leveling mortar 1/4" to 1/2" thick according to manufacturer's specifications. Install floor covering after the mortar has cured.

Special Precautions

Isolation Membrane: Install the mat above the membrane, whenever possible, unless recommended otherwise by the membrane manufacturer.

Insulation: Insulation dramatically enhances the performance and efficiency of floor-warming systems. Do not install rigid insulation directly above or below backer board or mortar.

Mosaic Tile: When installing mosaic tile, it is recommended to apply a two-step process. First, embed the mat in a thin self-level mortar bed (1/4"-3/8"), then thin-set the mosaic tile according to typical practice.

Expansion Joints: Do not install heating mats through an expansion joint. Install mats right up to the joint, if necessary, but not through the joint.

DOUBLE-PLYWOOD OVER FRAME FLOOR

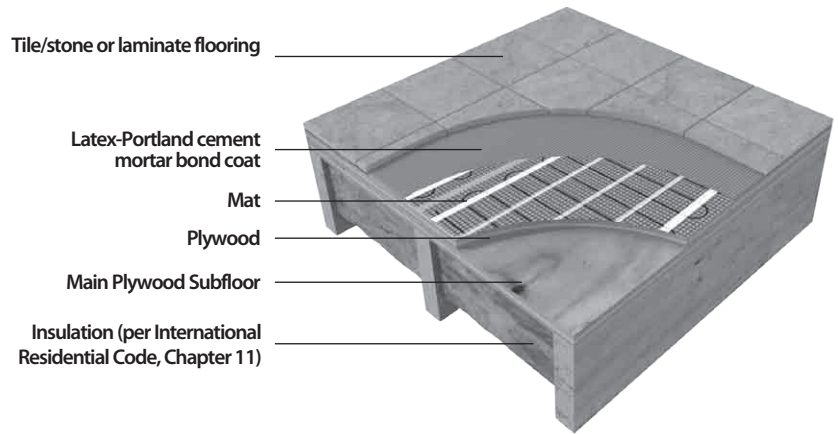

CEMENT BACKERBOARD OVER FRAME FLOOR

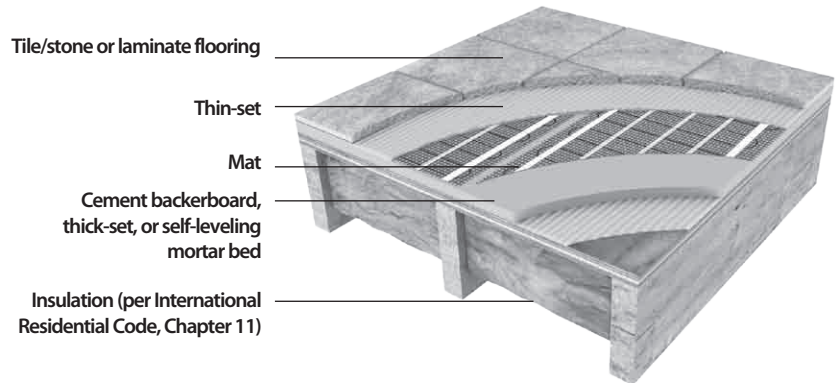

THIN-SET OVER SLAB ON GRADE

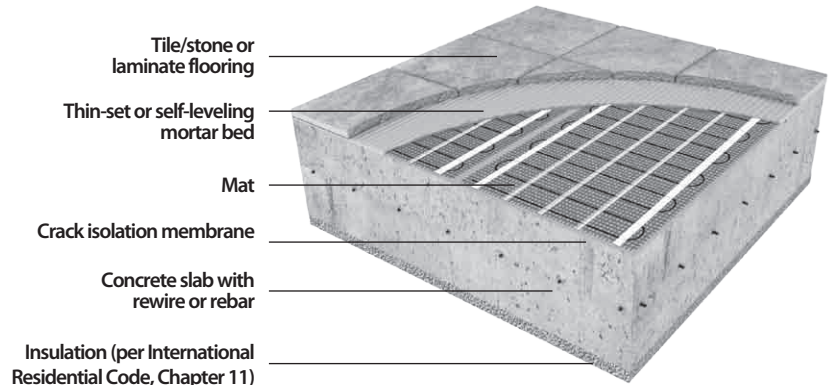

CAUTION
 Never bang a trowel on the heating wire to remove excess mortar from the trowel. This could damage the heating wire.

Phase 6: Control Installation

STEP 6.1: Install the Controls

If it has not already been done, install an electrical box for the SunStat. Do not forget to attach a single-gang mud-ring to mount the SunStat if a 4" square box was used. See Phase 3 for details.

STEP 6.2

Refer to the wiring diagrams in the Appendix of this manual for typical configurations.

STEP 6.3

Read and follow the instructions included with the SunStat thermostat for complete connection instructions, requirements, and mounting.

STEP 6.4

Make any final connections to the circuit breaker or branch circuit source

STEP 6.5: System Start Up

After all controls are installed, do not energize the system, except to briefly test operation of all components (no longer than 10 minutes). **Do not put the system into full operation until the tile or flooring installer verifies all cement materials are fully cured (typically two to four weeks).** See mortar manufacturer's instructions for recommended curing time.

NOTE: Most laminate and wood floor manufacturers specify their flooring should not be subjected to temperatures over 82° to 84°F (27° to 28°C). Check with the flooring dealer or manufacturer and set the thermostat appropriately.

Refer to the installation sheets provided with the controls for proper setting. The system should now operate as designed. Please leave this instruction manual, SunStat instructions, and copies of photos of the installed heating system with the end user.

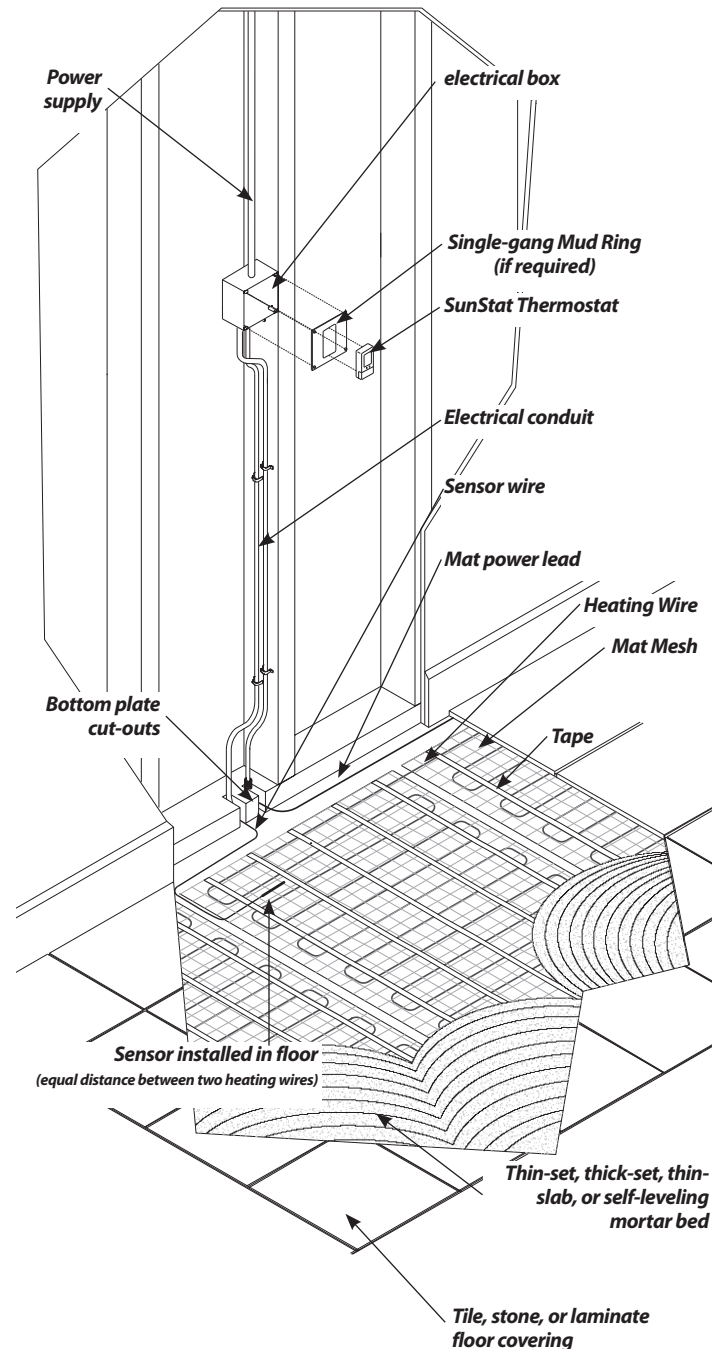

General layout of the SunTouch Mat installation

Appendix

Types of turns

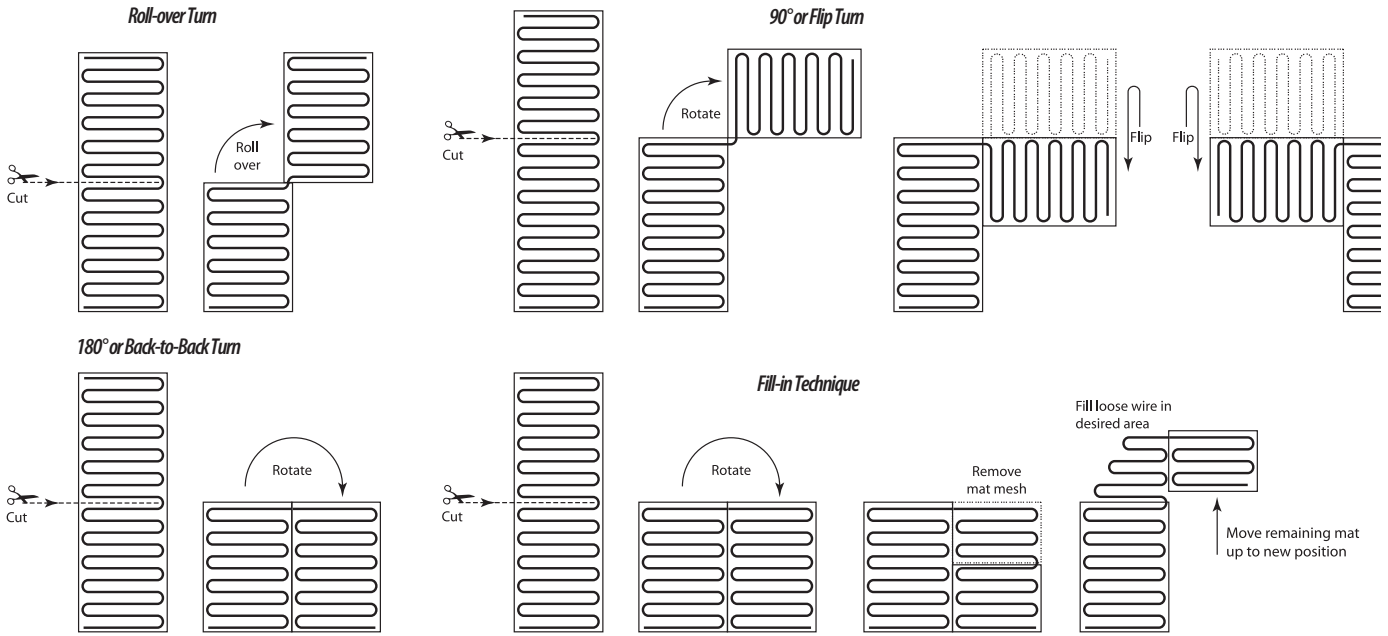

Step-by-step layout for a typical bathroom

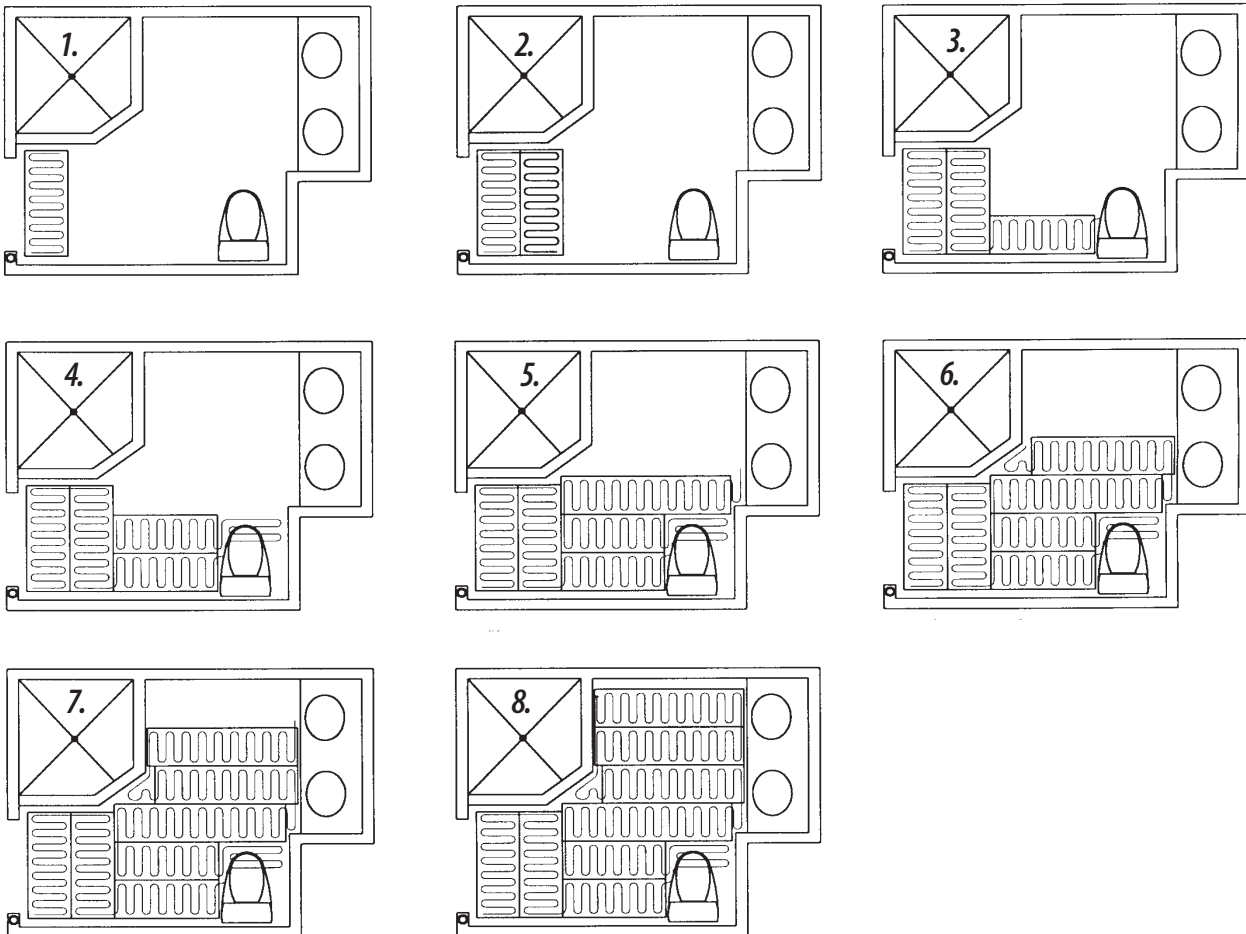

Bathroom layout 1: One 30" x 20' mat

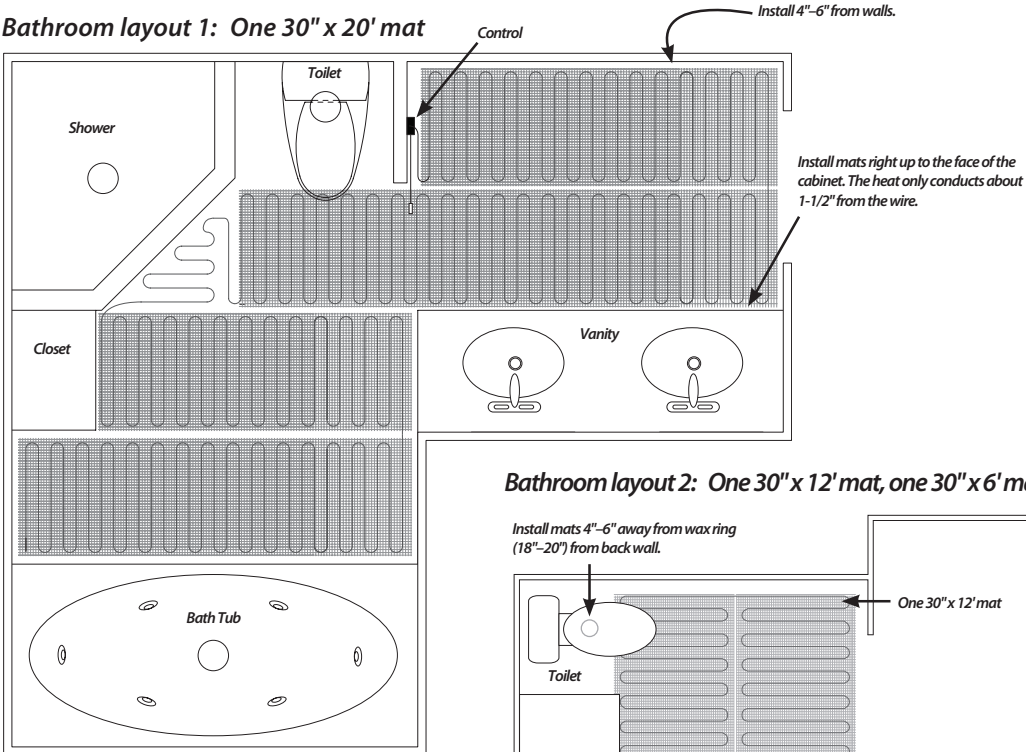

Bathroom layout 2: One 30" x 12' mat, one 30" x 6' mat, and one 30" x 32' mat.

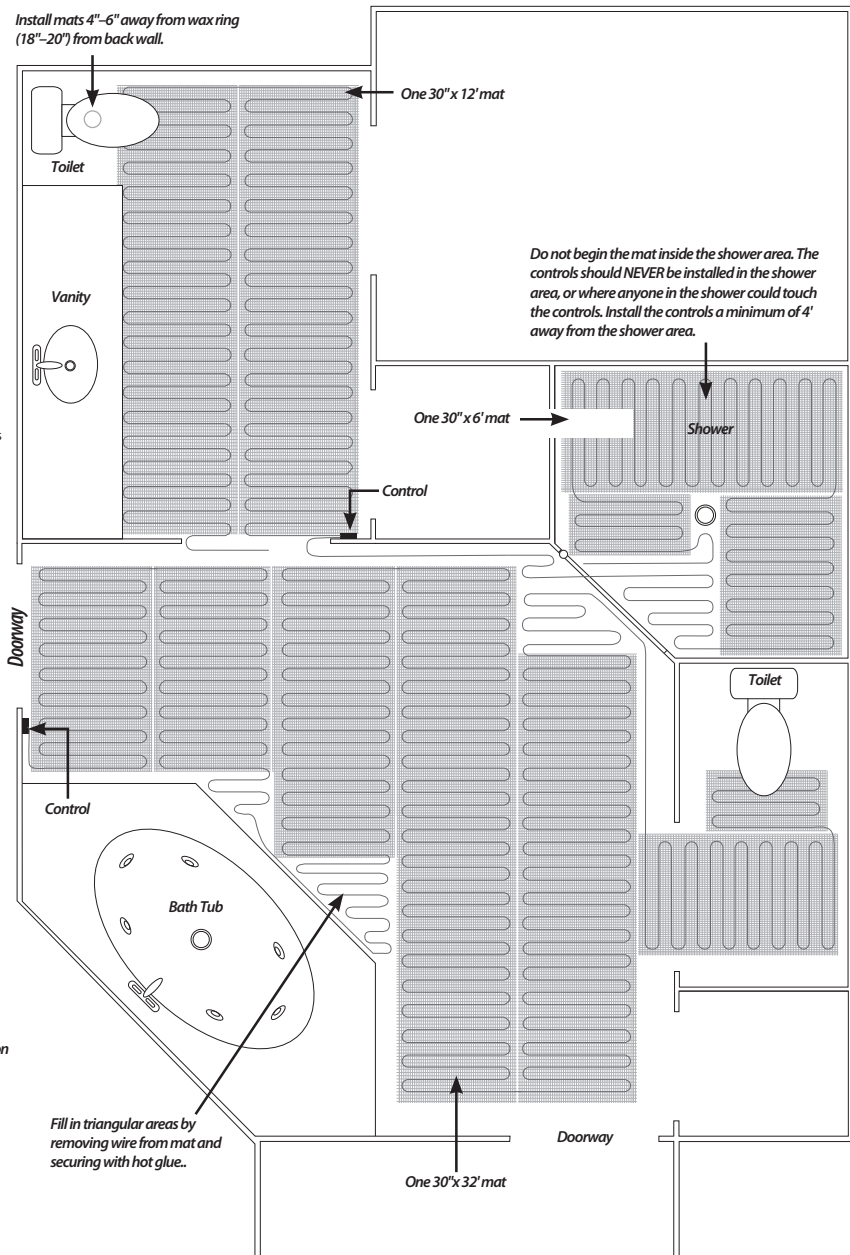

Locate power lead and factory connection to heating wire at least 1' outside the shower area.

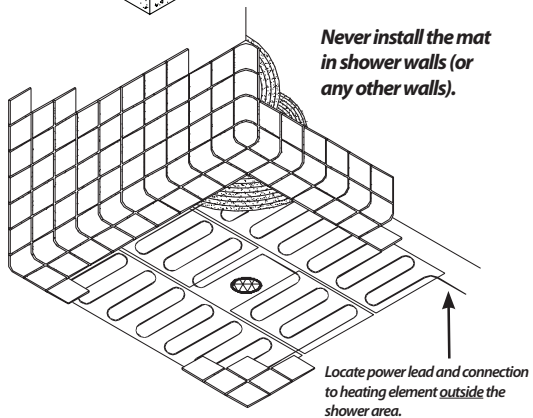
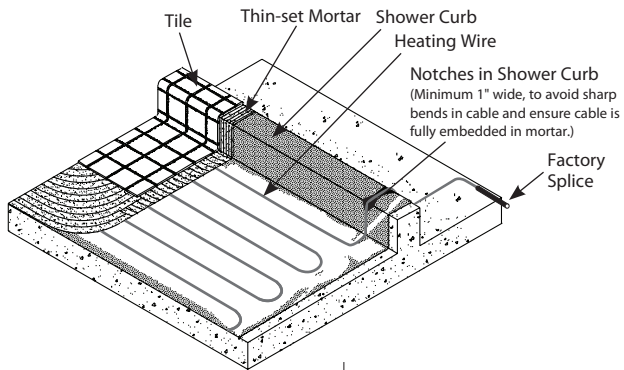

IMPORTANT

See phase 4 for complete details and Cautions. This application into a shower area must be verified by the local inspector or the authority having jurisdiction.

Fill in triangular areas by removing wire from mat and securing with hot glue..

Front entryway layout: Two 30" x 10' mats, one 30" x 6' mat

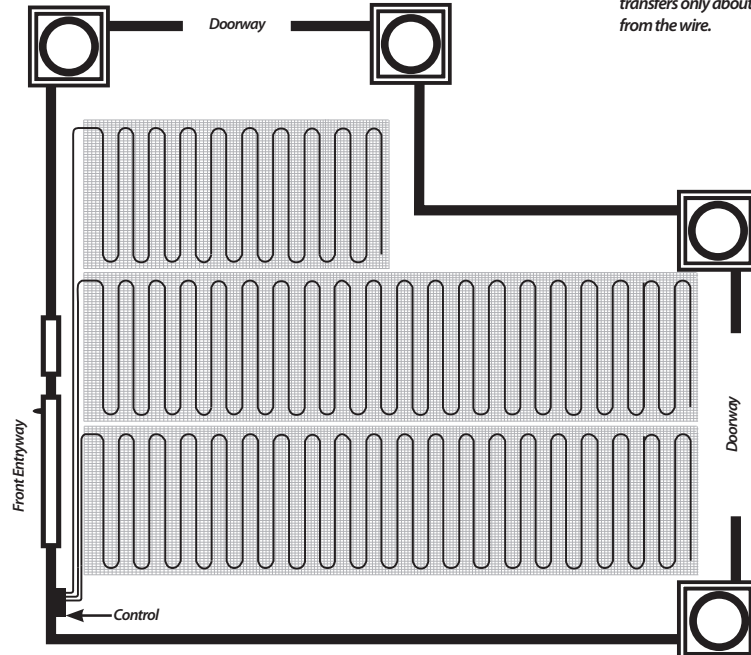

Install mats right up to the face of the vanity. The heat transfers only about 1-1/2" from the wire.

Small bath layout 1: One 30" x 6' mat

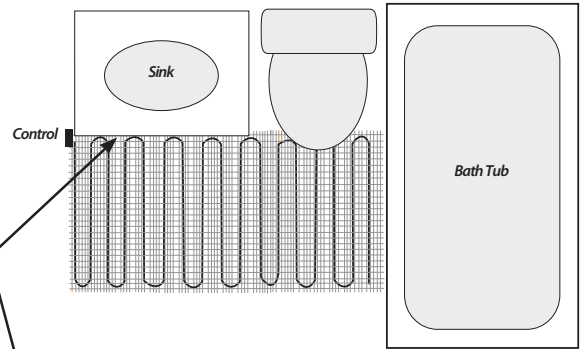

Small bath layout 2: One 30" x 10' mat

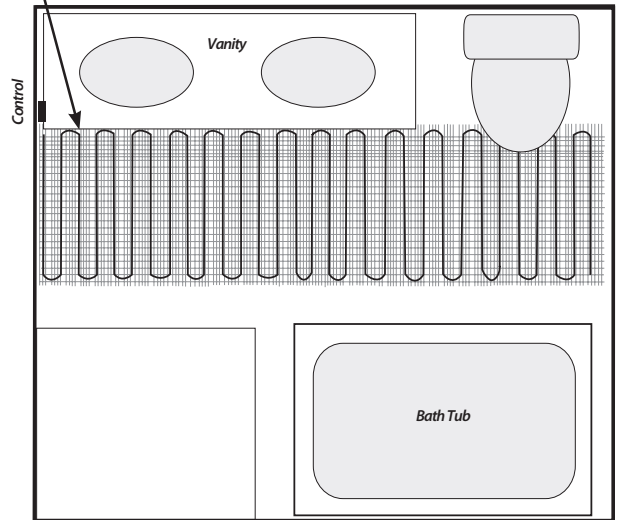

120/240VAC Control Wiring Diagrams

Typical Wiring for one mat with SunStat Control (120/240VAC)
20-amp circuit.

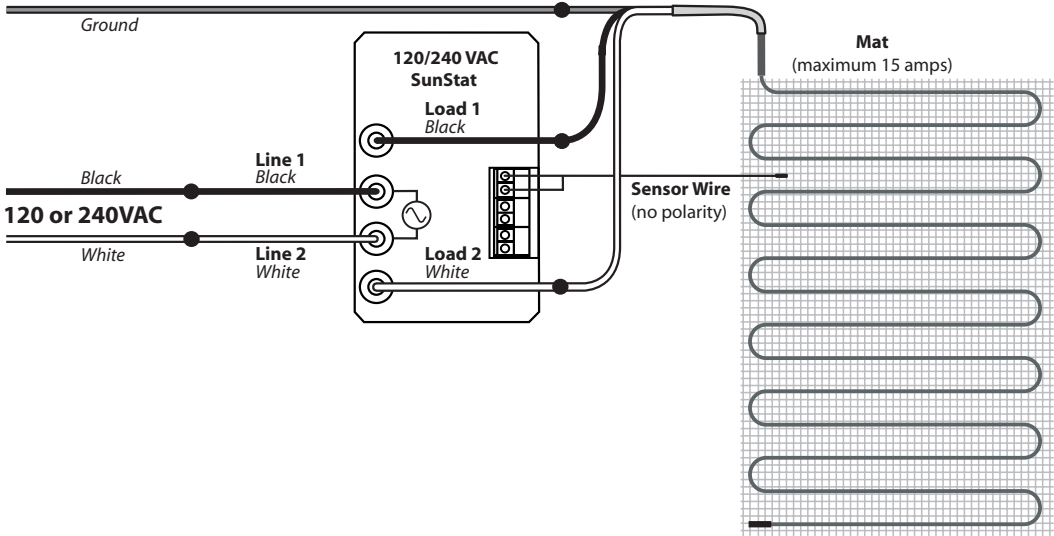

Typical Wiring for multiple mats with SunStat Control (120/240VAC)
20-amp circuit.

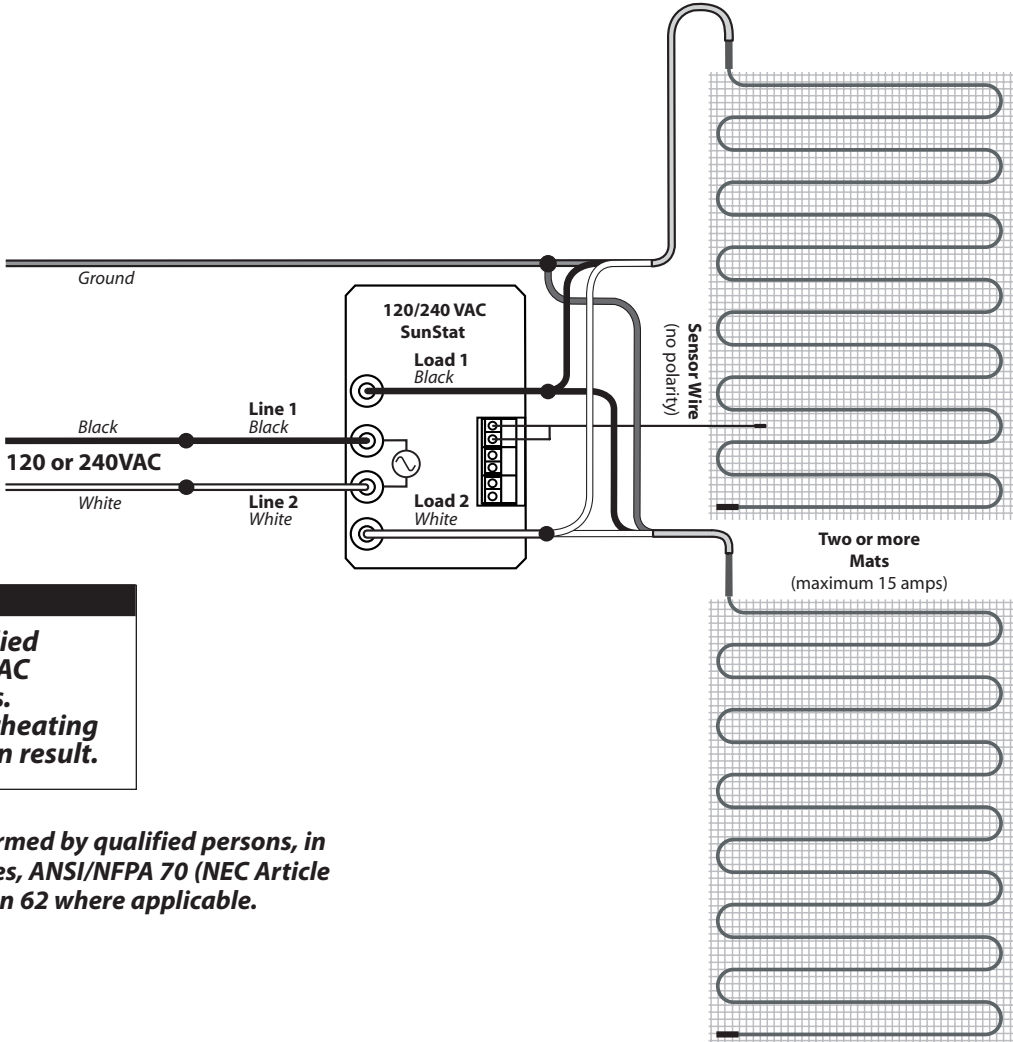

⚠ CAUTION
 Make sure 120 VAC is supplied to 120 VAC mats and 240 VAC is supplied to 240 VAC mats. Otherwise, dangerous overheating and possible fire hazard can result.

Note: Installation must be performed by qualified persons, in accordance with local codes, ANSI/NFPA 70 (NEC Article 424) and CEC Part 1 Section 62 where applicable.

Connecting Multiple Mats

NOTE: The SunStat is not shown in these diagrams in order to simplify them. These diagrams are given only as examples of how to properly connect multiple mats. Care must be taken not to overfill a box. Be sure to use wire nuts that are the correct size for the connections being made. Follow all codes for wiring. If in doubt, consult an electrician.

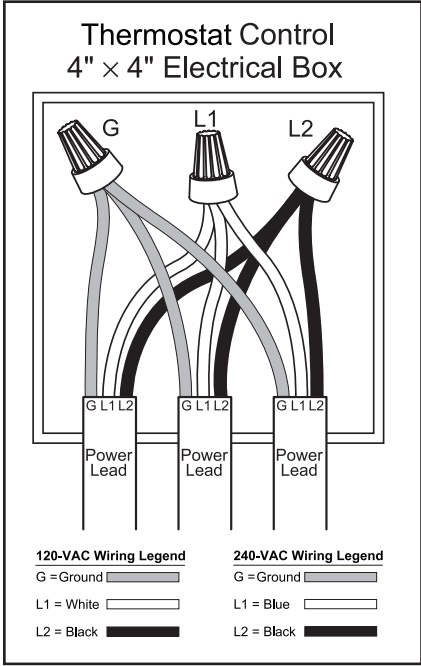

Illustration showing how to connect three mats at the thermostat control electrical box.

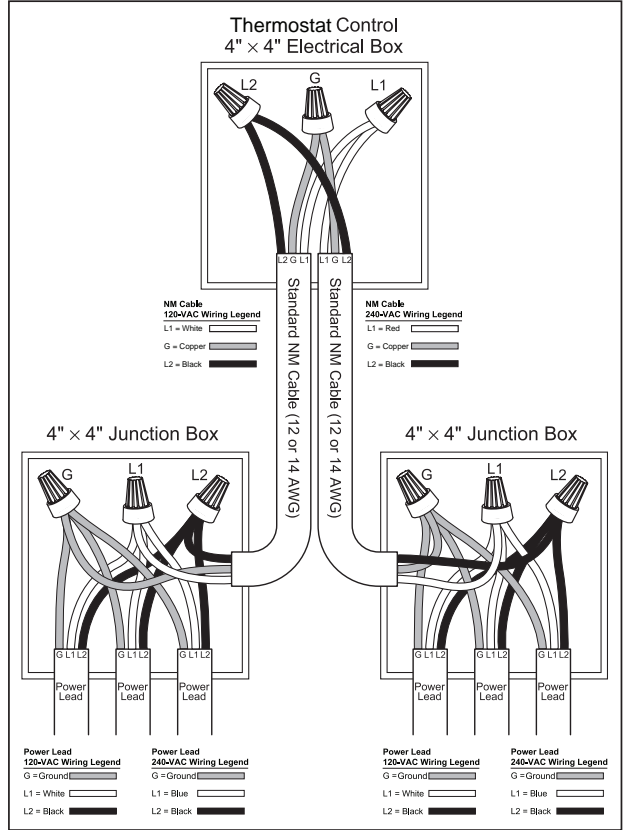

Illustration showing how to connect multiple mats from multiple junction boxes at one thermostat control electrical box.

Troubleshooting Guide

If problems arise with the SunTouch Mat or its related electrical components, please consult this troubleshooting guide. If not qualified to perform electrical work, it is highly recommended a qualified, licensed electrician be hired.

Any electrical troubleshooting work should be performed with the power removed from the circuit, unless otherwise noted.

Although this troubleshooting guide is provided to assist with problems experienced with a SunTouch system, results are never guaranteed. SunTouch does not assume any liability or responsibility for damage or injury that may occur from using this guide. If problems with the system persist, call the manufacturer.

<i>Problem</i>	<i>Possible Cause</i>	<i>Solution</i>
Mat resistance measurement is outside the range printed on the nameplate label.	An analog meter (using a moving needle) was used to take the reading.	Obtain a digital multi-meter and re-measure the resistance.
	If measurement shows an open or short circuit, the Heating Wire has been damaged.	Record resistance between all wires and contact the manufacturer.
	If measurement is just a little low or high, room temperature has affected the resistance.	Make the room temperature 75°–85°F (24°–30°C), or contact the manufacturer.
	The resistance measurement could be from more than one mat wired in series, or wired in parallel. Either will provide false resistance readings.	Make sure resistance measurements are for only one mat at a time.
	The multi-meter may be set to the wrong scale.	The multi-meter should typically be set to the 200 ohms (200Ω) scale. For mats with resistance range higher than 200 ohms on the nameplate label, set the meter to the 2000 ohm (2kΩ) scale.
Floor is not getting warm.	Mat has been damaged.	Measure mat resistance. Check for both “open circuit” and “short circuit” as detailed earlier in this manual. If damaged, record resistances between all wires and contact the manufacturer.
	GFCI has tripped, indicated by a light or “GFCI TRIP” on the control.	Check for loose wire connections. Reset the GFCI on the control or circuit breaker. If it trips again, check for a short circuit in the mat as detailed earlier in this manual. If mat is damaged, record resistance between all wires and contact the manufacturer. If mat is not damaged, replace the GFCI control. Also see “GFCI conflicts” below.
	Incorrect voltage supplied, or mismatched electrical components used.	Measure “line” voltage, then measure “load” voltage. 120 VAC mats have black and white power leads. 240 VAC mats have black and blue power leads.
	Uninsulated concrete slab floor.	Surface temperatures rise slowly an uninsulated slab and heat is lost to the ground below.. If, after 5 to 8 hours of heating, the floor is not warmer to the touch, check for mat damage (see “Mat has been damaged” above). A clamp-on ampmeter may be used to verify the amps are correct to each mat.
	Mats are wired in “series” or “daisy chained” (end-to-end).	Multiple mats must be connected in “parallel” (or black-to-black, white-to-white).
Floor heats continuously.	Incorrect wiring. The control was “bypassed” when it was wired to the power supply.	Make sure wiring connections are correct. Consult the wiring diagram on the back of the control the instructions that came with the control, or the wiring diagram in this manual.
	Defective control.	Return control to dealer for replacement.
Control is not working correctly.	If a programmable control, the programming may be incorrect.	Carefully read and follow control programming instructions.
	Incorrect voltage supplied, or mismatched components used.	Test voltage, verify parts. See “Incorrect voltage supplied” above.
	Floor sensor is not wired properly, or is not working properly.	Make sure only one floor sensor is connected to the control. Also see “Sensor is loose or broken” above.
	Loose connection(s) on line side and/or load side of control.	Remove and reinstall the wire nuts at each connection. Make sure the wire nuts are tight. Check all connections back to the breaker.
	Defective control.	Return control to dealer for replacement.
Control is not working at all.	No power is supplied.	Check circuit breaker. Measure voltage at the control. Check all connections between breaker and control.
	Defective control.	Return control to dealer for replacement.
GFCI conflicts and false-trips	An electric motor or a ballasted light source is sharing the circuit with the mat.	Electric motors and other electrical devices can cause a GFCI to false-trip. Run a dedicated circuit to the floor-warming system or select a different branch circuit.

WattsRadiant[™]
Floor Heating & Snow Melting

Electric Floor-warming Products

25-year Limited Warranty

Watts Radiant (the Company) warrants its electric floor-warming mats and cables (the Product) to be free from defects in materials and workmanship for twenty-five (25) years from the date of manufacture. Thermostats and controls sold by Watts Radiant are warranted, parts and materials, for two (2) years from the date of purchase. The sole remedy for controls is product replacement. This warranty is transferable to subsequent owners.

Under this Limited Warranty, Watts Radiant will provide the following:

If the Product is determined by Watts Radiant to be defective in materials and workmanship, and has not been damaged as a result of abuse, misapplication or modification, the Company will refund all or part of the manufacturer's published list price of the Product at the time of purchase in accordance with the following: 100% for the first ten (10) years, then prorated on a diminishing 25-year scale for the remaining warranty period.

For example:

- (1) Product found defective in the 5th year will receive the full manufacturer's published list price of the Product at the time of purchase;
- (2) Product found defective in the 15th year, with 10 years remaining in the warranty period, will receive 10/25ths of the manufacturer's published list price of the Product at the time of purchase.

In order to make a claim, you must:

- (a) Provide the Company with sufficient details relating to the nature of the defect, the installation, the history of operation, and any repairs that may have been made.
- (b) At the Company's discretion and at the owner's expense, ship the Product to the Company or the Company's local representative or distributor.
- (c) Provide proof that the Product was installed in accordance with the applicable Product Installation Manual and any special written design or installation guidelines by Watts Radiant for this project.
- (d) Provide proof that the Product was installed in accordance with the National Electrical Code (NEC) or the Canadian Electrical Code (CEC), and all applicable local building and electrical codes.
- (e) Provide a retail sales receipt or proof of purchase.

The following are not covered by this Limited Warranty:

- (a) Any incidental or consequential damage, including inconvenience, loss of time or loss of income.
- (b) Any labor or materials required to repair or replace the Product or control, not authorized in writing by the Company.
- (c) Any labor or materials required to remove, repair or replace flooring materials.
- (d) Any freight or delivery costs related to the Product, the control, or any related flooring or electrical products.

Watts Radiant assumes no responsibility under this warranty for any damage to the Product caused by any trades people, visitors on the job site, or damage caused as a result of post-installation work. The staff at Watts Radiant is available to answer any questions regarding the proper installation or application of the Product at this toll-free phone number: 800-276-2419. If you are ever in doubt about the correct installation procedure to follow, or if the Product appears to be damaged, you must call us before proceeding with the installation, or proposed repair.

WATTS RADIANT DISCLAIMS ANY WARRANTY NOT PROVIDED HEREIN, INCLUDING ANY IMPLIED WARRANTY OF MERCHANTABILITY OR IMPLIED WARRANTY OF FITNESS FOR A PARTICULAR PURPOSE. WATTS RADIANT FURTHER DISCLAIMS ANY RESPONSIBILITY FOR SPECIAL, INDIRECT, SECONDARY, INCIDENTAL, OR CONSEQUENTIAL DAMAGES ARISING FROM OWNERSHIP OR USE OF THIS PRODUCT, INCLUDING INCONVENIENCE OR LOSS OF USE. THERE ARE NO WARRANTIES WHICH EXTEND BEYOND THE FACE OF THIS DOCUMENT. NO AGENT OR REPRESENTATIVE OF WATTS RADIANT HAS ANY AUTHORITY TO EXTEND OR MODIFY THIS WARRANTY UNLESS SUCH EXTENSION OR MODIFICATION IS MADE IN WRITING BY A CORPORATE OFFICER.

DUE TO DIFFERENCES IN BUILDING AND FLOOR INSULATION, CLIMATE, AND FLOOR COVERINGS, WATTS RADIANT MAKES NO REPRESENTATION THAT THE FLOOR TEMPERATURE WILL ACHIEVE ANY PARTICULAR TEMPERATURE, OR TEMPERATURE RISE. UL® STANDARD LISTING REQUIREMENTS LIMIT THE HEAT OUTPUT OF REGULAR MATS TO 12 WATTS PER SQUARE FOOT, CABLES TO 15 WATTS PER SQUARE FOOT DEPENDING ON CABLE INSTALL SPACING, AND UNDERFLOOR MATS TO 10 WATTS PER SQUARE FOOT, AND AS SUCH, USERS MAY OR MAY NOT BE SATISFIED WITH THE FLOOR WARMTH THAT IS PRODUCED. WATTS RADIANT DOES WARRANT THAT ALL PRODUCTS WILL PRODUCE THE RATED OUTPUT LISTED ON THE PRODUCT NAMEPLATE, WHEN OPERATED AT THE RATED VOLTAGE.

Some states do not allow the exclusion or limitation of incidental or consequential damages and some states do not allow limitations on how long implied warranties may last. Therefore, the above limitations or exclusions may not apply to you. This warranty gives you specific legal rights and you may also have other rights, which vary from state to state. SO FAR AS IS CONSISTENT WITH APPLICABLE STATE LAW, ANY IMPLIED WARRANTIES THAT MAY NOT BE DISCLAIMED, INCLUDING IMPLIED WARRANTIES OF MERCHANTABILITY OR FITNESS FOR A PARTICULAR PURPOSE ARE LIMITED IN DURATION TO TWENTY-FIVE YEARS FROM THE DATE OF MANUFACTURE.

Terms and Conditions

Shipping Discrepancies: Incoming materials should be inventoried for completeness and for possible shipping damage. Any visible damages or shortages must be noted prior to accepting the material. Once the receiving personnel accept the material on their dock, they have relieved the freight company of any responsibility. Any discrepancy concerning type or quantity of material shipped, must be brought to the attention of Watts Radiant within 15 days of the shipping date entered on the packing slip for the order.

Return Policy: Watts Radiant items may be returned within 180 days from the date of purchase, if they are not damaged or used. There will be a 25% restock charge applied to items returned due to overstock or customer order error. All returned items must be in new condition. Products, controls or other parts that have a quality defect will be replaced (not credited) at no charge to the customer. If an item is shipped in error, there will be no restocking charge. All items returned, for replacement, credit or repair, must have a Returned Goods Authorization (RGA) number, or they will not be accepted. **Please return the product to the original point of purchase.** Products older than 180 days are excluded from these terms and conditions and may not be returned.

Products that have been damaged, or Products that have been cut, may not be returned. This includes Products that have had mortar or concrete materials applied to them. These Products cannot be repaired and cannot be resold; therefore, we cannot accept them.

Effective: APRIL 1, 2006. This warranty applies to all Products purchased after this date.

Watts Radiant 4500 E. Progress Place Springfield, MO 65803-8816
800-276-2419 (toll-free phone) 417-864-6108 (phone) 417-864-8161 (fax) www.wattsradiant.com

Affiliations:



The SunTouch manufacturing facility's Quality System is an ISO 9001:2008 registered facility through LRQA.

warmyourfloor™

1-866-558-3369 (toll-free phone)

1-866-558-2010 (fax)

info@warmyourfloor.com (email)

warmyourfloor.com (web)