

RCA



RCA and the RCA logo are trademarks used under license by DTI SERVICES LLC. – www.rca-brand.com.

M27PG135f User Manual

Contents

Important Safety Precautions.....	1
1.Product Description.....	2
1.1 Packing list.....	2
2.Installation and Connection.....	2
2.1 Display installation.....	2
2.2 Instruction of Base Installation.....	3
2.3 Signal line connection.....	4
2.4 Audio output.....	4
3. Operation of Display.....	4
3.1 Safety protection.....	4
4. Technical Specificatins of Product.....	4
5. Basic Troubleshooting.....	5
THIS LIMITED WARRANTY DOES NOT COVER.....	7
HOW WARRANTY SERVICE IS PROVIDED.....	8

Important Safety Precautions

1. Please read all the instructions carefully before using this product.
2. BE SURE TO unplug the power cord when cleaning LCD. Never clean it with liquid detergent or spraying detergent, but wipe it with wet soft cloth. If it is still not clean, please use special detergent for LCD.
3. DO NOT use accessories not authorized by the manufacturer, other wise they may incur danger.
4. When disconnecting the power cord of display or power adapter, always remember to hold the plug instead of puling the wire to unplug the power cord.
5. Keep the display away from water sources such as bath tub, washbasin, sink or washing machine. DO NOT place the display on wet floor or near a swimming pool, or press LCD surface with fingers or hard objects.
6. The grooves and openings on the back and bottom of the shell are for ventilation purpose and also for guaranteeing the reliability of the elements and preventing them from overheating; in order to prevent the vents from blocking; DO NOT place the display on bed, sofa, carpet or other similar surfaces; DO NOT place the display near to or on heat radiator or heater; DO NOT put the display into embedded device, unless it is provided with adequate ventilating equipment.
7. Only the type of power source indicated on the nameplate applies to this display. If you have any questions on the type of power source you use, please consult the dealer of the display or local administration of power supply.
8. Since there is high voltage or other risks when the shell is opened or moved, please DO NOT repair the display by yourself, but request qualified maintenance staff to carry out.
9. In one of the following cases, please unplug the display or the power adapter and ask qualified maintenance staff for help:
 - a. The power cord or the plug is impaired or worn.
 - b. The display falls off or the shell is damaged.
 - c. The display is obviously abnormal.
10. Please place the display in a cool, dry and well ventilated place.

1. Product Description

1.1 Packing list

Please check the following items in the packing case before installation:

- One LCD display (including the base)
- One DP cord, one AC adaptor
- One user manual

If any of above items is missing, please contact with the dealer.

⚠ CAUTION

- Unplug the power cord before moving or installing the monitor to avoid electric shock.
- Always use genuine RCA components to ensure safety and product performance.
- The product warranty will not cover damage or injury caused by the use of unauthorized components.
- It is recommended to use the supplied components.
- The product figures and screen displays used in this manual are examples to help consumers use the product and may differ from the actual product.
- Do not apply foreign substances (oils, lubricants, etc.) to the screw parts when assembling the product. (Doing so may damage the product.)
- Applying excessive force when tightening screws may cause damage to the monitor. Damage caused in this way will not be covered by the product warranty.
- Do not carry the monitor upside down by just holding the base. This may cause the monitor to fall off the stand and could result in personal injury.
- When lifting or moving the monitor, do not touch the monitor screen. The force applied to the monitor screen may cause damage to it.

2. Installation and Connection

2.1 Display installation

Installation instructions

- This Monitor should be installed adjacent to an easily accessible AC power socket.
- For the sake of safety, we suggest that a suitable UL certified wall-mounted bracket or base be used.
- In order to prevent injury, this Monitor shall be placed on a stable and level surface or fixed on a firm wall.
- For wall-mounting, please ask a professional to do so. Improper installation may cause instability of this monitor .
- DO NOT place this monitor in places with mechanical vibration.
- DO NOT place this monitor in places where insects, rodents, or other pests are accessible.

- DO NOT install this monitor directly opposite to air-conditioner, otherwise its inner panel may be dewed and cause failure.
- DO NOT place this monitor in places with strong electromagnetic fields, otherwise it may be interfered by the electromagnetic wave and get damaged.

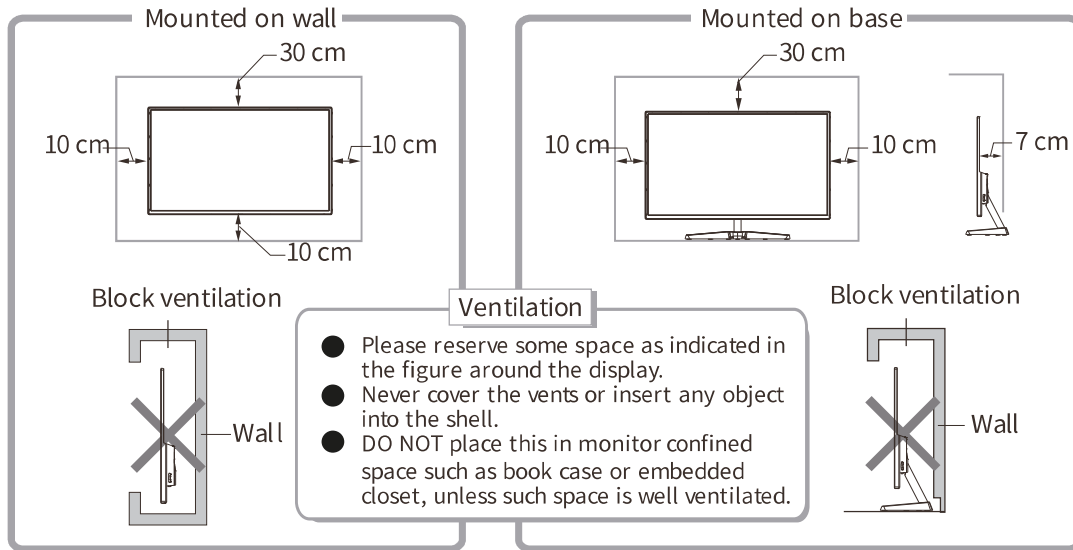

2.2 Instruction of Base Installation

1. Base installation steps:

- ① Insert the base into the support and lock 3 M4*16 screws, as shown in Figure 1.
- ② Insert the base into the hole position of the rear shell at an angle in the direction of the arrow, as shown in Figure 2.
- ③ Rotate the entire base clockwise down and load, as shown in Figures 2 and 3.

Base installation steps:

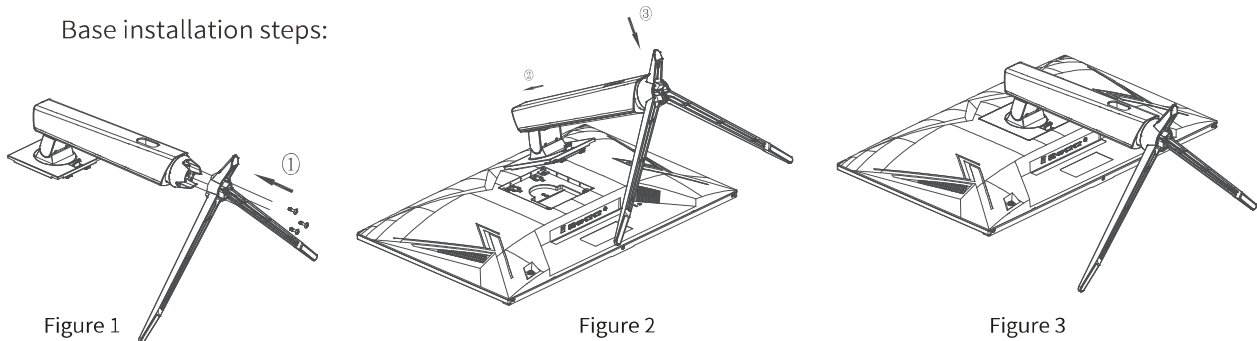

2. Base removal steps:

- ① Push the slider near the base VESA cover up, as shown in Figure 1.
- ② Rotate the entire base upwards counterclockwise, as shown in Figure 1.
- ③ Take out the base obliquely in the direction of the arrow, as shown in Figure 2.
- ④ Unscrew the 3 M4*16 screws on the base and pull out the base in the direction of the arrow, as shown in Figure 3.

To remove the entire base

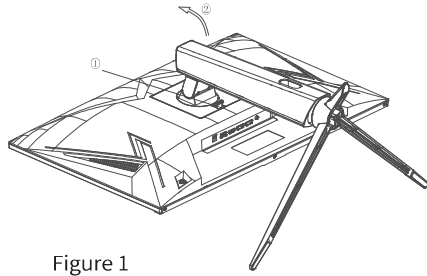

Figure 1

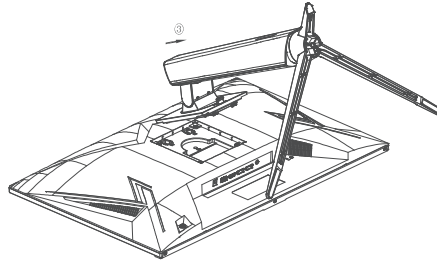

Figure 2

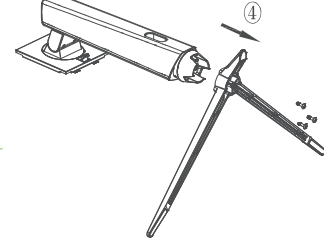

Figure 3

Installation Tips

- If you need to remove the base, first place the monitor face down in the original packaging protection material to avoid screen damage.
- For a base with quick disassembly and assembly functions, press the release button to remove the base in the reverse operation.

2.3 Signal line connection

Connect the signal line to output interfaces signal of HDMI/DP/USB-C signals of PC, and the connect the other end of the signal line to the corresponding signal input port of the display.

2.4 Audio output

This monitor supports earphone audio output.

3. Operation of Display

3.1 Safety protection

When the video signals of PC exceeds the frequency range of the display, the horizontal and field synchronizing signals will be shut down to protect the display. Then, you have to set the PC output frequency to an acceptable range so as to make the display work normally.

3.2 Introduction to rocker functions

Initial state:

Rocker Up	Signal source input
Rocker Down	KVM Selection
Rocker Left	Game Plus Shortcut key
Rocker Right	Video Preset Shortcut key
Press Rocker	Short press to turn on the monitor/Open menu,press and hold for 3s to turn off the monitor

Enter the function menu:

Rocker Up	Menu Up / Adjust variable selection
Rocker Down	Menu Down / Adjust variable selection
Rocker Left	Return to the previous menu
Rocker Right	Enter to the next menu, and confirm variable changes.
Press Rocker	Short press to Close menu/press and hold for 3s to turn off the monitor

3.3 OSD Function

First order menu	Secondary menu	Third Level Menu	Fourth Level Menu	Default	
Display	Brightness	0-100	/	90	
	Contrast	0-100	/	50	
	Black Equalize	0-100	/	50	
	Preset	Standard/User/Movie/Photo/RTS/FPS1/FPS2	/	User	
	Aspect Ratio	Full/ 16:9/4:3	/	Full	
	Sharpness	0、25、50、75、100	/	50	
Color	Color Temperature	Warm/Normal/Cool/sRGB/User	Red/Green/Blue	Normal	
	Gamma	Off/1.8/2.0/2.2/2.4	/	2.2	
	Hue	0-100	/	50	
	Saturation	0-100	/	60(待定)	
	Low Blue Light	0、25、50、75、100	/	0	
Gaming Setup	Freesync/G-Sync	Off/On	/	Off	
	Overdrive	Off/Low/Middle/High	/	Off	
	Game Plus	Timer	Off 15:00/30:00/45:00/60:00/90:00	/	Off
		Crosshair	Off/Model 1/Model 2/Model 3/Model 4	/	Off
		FPS Counter	Off/On	/	Off
	DCR	Off/On	/	Off	
	MPRT	Off/On	/	Off	

Advanced Settings	HDR	Off/Auto	/	Off
	RGB Light	Off/On	/	On
	KVM	USB OFF/USB UP/Type-C	/	USB OFF
Input	Auto	/	/	Auto
	Type-C	/	/	/
	DP	/	/	/
	HDMI2	/	/	/
	HDMI1	/	/	/
System	Language	ENGLISH/简体中文/繁体中文/한국어	/	ENGLISH
	OSD Setup	H-Position	0-100	50
		V-Position	0-100	50
		OSD Timeout	/15/30/45/60	15
		Transparency	0/25/50/75/100	25
	Audio	Mute	Off/On	Off
		Volume	0-100	50
Reset	Confirm/Cancel	/	/	

4. Technical Specifications of Product

Panel size	27"
Optimal working resolution	2560×1440@240Hz
Power input	24V \approx 7A
Power supply management system : Normal working Standby	\leq 168W \leq 0.5W
Requirements for working environment Altitude Working temperature and humidity Warehousing temperature and humidity	\leq 5000m 0°C~40°C 20%~85% -10°C~60°C 10%~90%

5. Basic Troubleshooting

Phenomenon	Troubleshooting
1. Light out/power indicator light is off	Check whether the display and the socket are well connected to power, and whether the display is in the shutdown mode.
2. Image over dark	Enter the menu “Brightness and Contrast” to adjust the brightness and contrast of the display.
3. Display over heat	Leave at least 5cm of distance for ventilation around the display and do not place articles on the display.
4. Dark/ light spots when powering on	This is a normal phenomenon. It is due to the backlight illuminates unevenly at the initial phase of powering on caused by temperature difference. The backlight can illuminates normally after 20 minutes, and then the dark/light spots will be corrected.
5. Image distortion, blinking, shaking	Check computer setting, select the correct resolution and re-adjust the refresh frequency.
6. Power off noise	It is a normal phenomenon caused by display discharging in the process of powering off.



The terms HDMI, HDMI High-Definition Multimedia Interface, HDMI trade dress and the HDMI Logos are trademarks or registered trademarks of HDMI Licensing Administrator, Inc.

Should your RCA monitor (“Product”) fail due to a defect in materials or workmanship under normal and proper use, during the warranty period set forth below, RCA will, at its option, repair or replace the Product. This limited warranty is valid only to the original purchaser of the Product and applies only when purchased lawfully and used within the United States including U.S. Territories.

WARRANTY PERIOD	HOW SERVICE IS HANDLED
<p>PARTS/LABOR: 2 Year from the date of original retail purchase</p>	<p>The original sales invoice specifying the Product and date of purchase is required to obtain warranty service.</p> <p>To ensure proper credit and avoid unnecessary charges, you must obtain an RMA (Return Merchandise Authorization) prior to returning any product to RCA.</p> <p>For customer assistance, please contact RCA: Call 1-800-722-2161 and select the appropriate option from the menu for Technical Support. Or by E-mail: support@rcacommercialtv.com</p>

- Replacement Products and parts are warranted for the remaining portion of the original warranty period or ninety (90) days, whichever is greater.
- Replacement Products and parts may be new, reconditioned, refurbished, or otherwise factory remanufactured.
- Any replaced Product and/or parts will be the property of RCA.

Disclaimer:

EXCEPT TO THE EXTENT PROHIBITED BY APPLICABLE LAW, ANY IMPLIED WARRANTY OF MERCHANTABILITY OR FITNESS FOR A PARTICULAR PURPOSE ON THE PRODUCT IS LIMITED IN DURATION TO THE DURATION OF THE ABOVE LIMITED WARRANTY PERIOD. UNDER NO CIRCUMSTANCES SHALL RCA, ITS SUBSIDIARIES, OTHER TRADE-MARK HOLDERS, OR ITS U.S. DISTRIBUTORS/DEALERS BE LIABLE FOR ANY INDIRECT, INCIDENTAL, CONSEQUENTIAL, SPECIAL OR PUNITIVE DAMAGES INCLUDING, WITHOUT LIMITATION, LOST GOODWILL, LOST REVENUES OR PROFITS, WORK STOPPAGE, IMPAIRMENT OF OTHER GOODS, COST OF REMOVAL AND REINSTALLATION OF THE PRODUCT, LOSS OF USE, OR ANY OTHER DAMAGES WHETHER BASED IN CONTRACT, TORT, OR OTHERWISE. RCA’ S TOTAL LIABILITY, IF ANY, SHALL NOT EXCEED THE PURCHASE PRICE PAID FOR THE PRODUCT.

SOME STATES DO NOT ALLOW THE EXCLUSION OR LIMITATION OF INCIDENTAL OR CONSEQUENTIAL DAMAGES OR LIMITATIONS ON HOW LONG AN IMPLIED WARRANTY LASTS, SO THE ABOVE EXCLUSIONS OR LIMITATIONS MAY NOT APPLY TO YOU. THIS LIMITED WARRANTY GIVES YOU SPECIFIC LEGAL RIGHTS AND YOU MAY ALSO HAVE OTHER RIGHTS THAT VARY FROM STATE TO STATE.

THIS LIMITED WARRANTY DOES NOT COVER:

- Service trips to deliver, pick up, install, educate how to operate, replace fuses, correct wiring, or correct unauthorized repairs and the removal and reinstallation of the Product for repair.
- Damage or loss to programs, data, or removable storage media.

- Damage or failure of the Product caused by installation or repair of antenna systems, cable converters, equipment supplied by a cable provider, or other components in a video system.
- Damage or failure of the Product caused by improper set-up or adjustment of end-user controls.
- Damage or failure of the Product caused by transportation and/or handling, including scratches, dents, chips, and/or other damage to the finish of the Product, unless such damage results from a defect in materials or workmanship and is reported within one (1) week of delivery (Call: 1-800-722-2161).
- Damage or failure of the Product when used in other than normal intended use.
- Damage or failure of Product caused by incorrect electrical current or voltage (including power surge), power failures, interruptions, or inadequate electrical service, including incorrect or insufficient AC supply.
- Damage or failure of the Product resulting from improper installation or operation of the Product contrary to the Product owner's manual and/or installation manual.
- Damage or failure of the Product caused by accidents, pests and vermin, lightning, wind, fire, flood, or other acts of nature.
- Damage or failure of the Product caused by abnormal conditions or an environment where the temperature and humidity is not adequately controlled.
- Damage or failure of the Product resulting from misuse, abuse, improper installation/repair/maintenance.
- Damage or failure of the Product caused by the use of accessories, parts, consumable cleaning products, or service not provided or approved by RCA.
- Damage or failure of the Product caused by unauthorized alternation, modification or incorporation into any other product or system components, or if it is used for other than the intended purpose.
- Damage or failure of the Product or missing items to any Product sold "As Is" , "With all Faults" or similar disclaimer.
- Products with original serial numbers that have been removed, altered, or cannot be readily determined.
- Increases in utility costs and additional utility expenses.
- Minor imperfections that do not materially alter or affect functionality.
- Burned-in images resulting from improper usage as described in the user manual.

The cost of repair or replacement under the above excluded circumstances shall be borne by you.

HOW WARRANTY SERVICE IS PROVIDED

If RCA, in its discretion, opts to replace rather than repair a Product, the replacement of a Product under this limited warranty is offered in two different EXCHANGE options:

- **REGULAR EXCHANGE:** RCA provides a prepaid shipping label for you to return a Product. RCA will ship your replacement Product within two (2) business days of receiving the returned Product.
- **ADVANCED EXCHANGE:** RCA ships replacement Product to you and includes a prepaid shipping label for you to return the replaced Product in the same box in which a replacement Product is provided. As a security measure, RCA may require a credit card number from you. In the event that the replaced Product is not returned or is returned damaged as a result of your negligence, the cost of the replacement Product will be charged. You must return the replaced Product to RCA within fourteen (14) days to avoid the credit card charge.

