

ABN: 84 568 553 950

Plumboss Australia
53 Taylor Street
(PO Box 793)
Bulimba QLD 4171
Australia

Phone: (07) 3373 3500
Fax: (07) 3373 3533

Importers and Manufacturers of Plumbing Equipment

2990 Hydraulic Pipe Cutter Operation and Maintenance

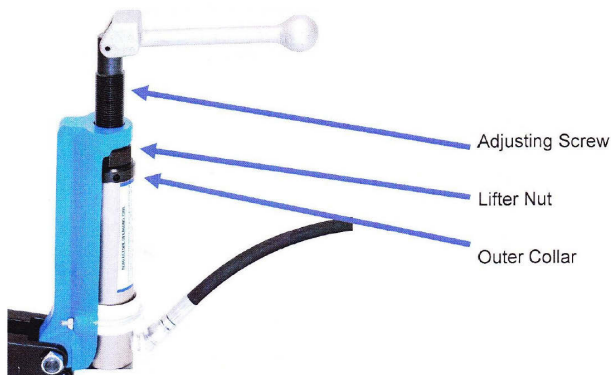

1. Turn adjusting screw until outer collar is at its **lowest** limit of travel. Do this for **EACH** cut.

2. Slide chain under pipe at location of cut.

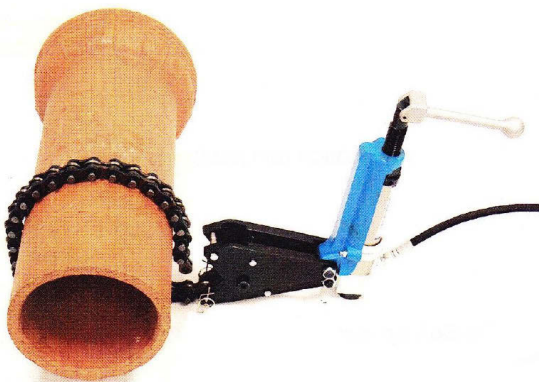

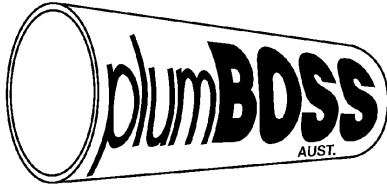

ABN: 84 568 553 950

Plumboss Australia
53 Taylor Street
(PO Box 793)
Bulimba QLD 4171
Australia

Phone: (07) 3373 3500
Fax: (07) 3373 3533

Importers and Manufacturers of Plumbing Equipment

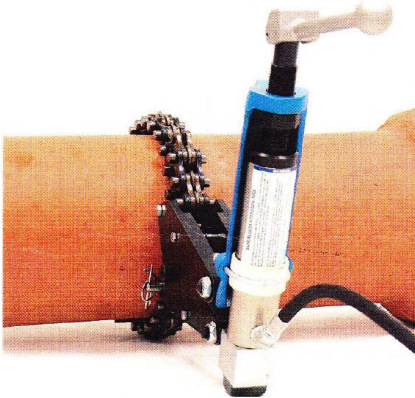

- 3. Pull chain over pipe and under tie bolt, then up between jaws as tightly as possible. Allow chain to relax so nearest pin is engaged in slots under upper nose jaw. Chain then can be folded over on itself.

Be sure pins are actually seated in their respective slots before applying any pressure.

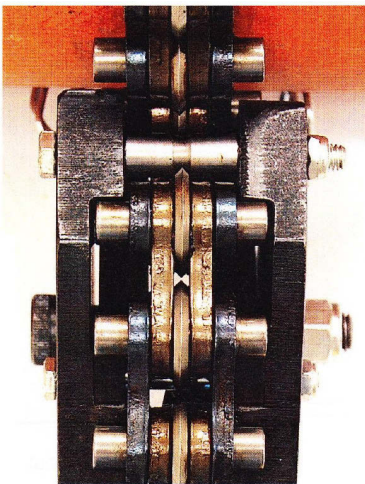

- 4. Rear pin location. (pin nest)

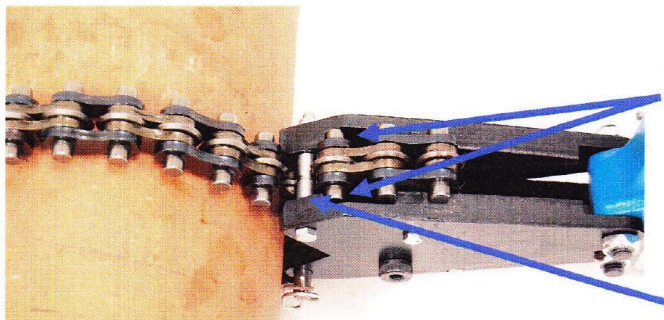

- 5. Rear pin location (pin nest)

Tie Bolt spacer

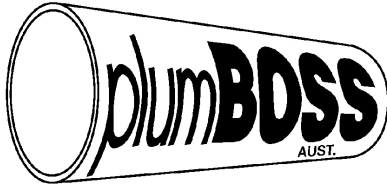

ABN: 84 568 553 950

Plumboss Australia
53 Taylor Street
(PO Box 793)
Bulimba QLD 4171
Australia

Phone: (07) 3373 3500
Fax: (07) 3373 3533

Importers and Manufacturers of Plumbing Equipment

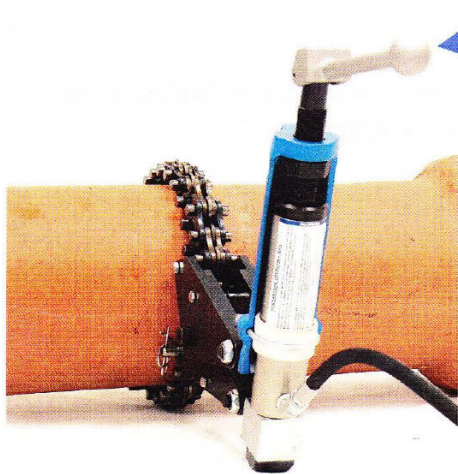

- 6. Take up remaining slack with adjusting screw.

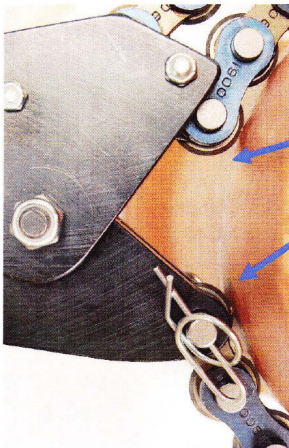

- 7. Cutter wheels should touch pipe.

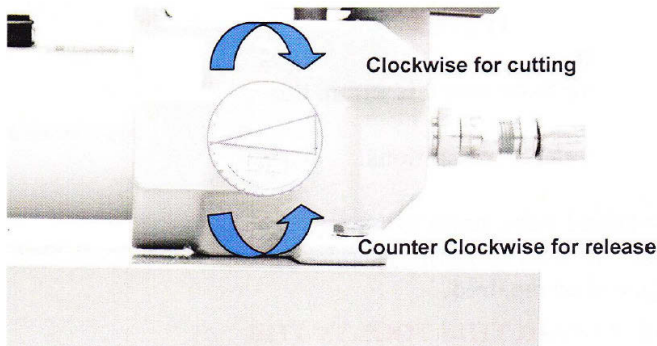

- 8. Turn valve clockwise on the pump until it is **HAND TIGHT. DO NOT USE A WRENCH.** Make strokes necessary to snap pipe. Turn knob counterclockwise after cut to release valve and retract piston.

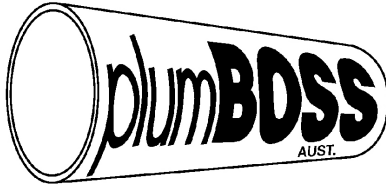

ABN: 84 568 553 950

Plumboss Australia
53 Taylor Street
(PO Box 793)
Bulimba QLD 4171
Australia

Phone: (07) 3373 3500
Fax: (07) 3373 3533

Importers and Manufacturers of Plumbing Equipment

WARNING NOTES

WHEELER-REX HYDRAULIC CUTTERS

Before operating this product, read the operating instructions and be sure you understand this product's purpose, use, capability and limitations. Used within its capability for its intended purpose and with proper preventative maintenance, this product will give long reliable service.

Failure to read and follow operating instructions and these warning notes can result in serious injury to operator and/or bystanders.

1. Do **NOT** allow anyone other than a qualified operator to operate this product.
2. After engaging the chain and tightening the adjusting screw, check to be sure that the chain pins are fully seated in the pin grooves in the jaw.
3. Take the pump directly back from the ram perpendicular to the pipe being cut, with the hydraulic hose extended to its full **10 foot length**.
4. **Place the protective plastic sheet, supplied with the tool, over the work. The adjusting screw handle for the ram will fit through the hole in the plastic sheet.**
5. Before applying any hydraulic pressure, check to be sure that, excepting the operator:
 - a. No one is near or in line with either end of the pipe
 - b. No one is within 25 feet of the tool
6. The operator should be wearing proper safety items - hard hat and safety glasses
7. Each Wheeler-Rex pump has a built-in pressure overload valve set to factory specifications in accordance with the rated capacity of the tool. This valve is a safety feature intended to prevent the build up of hydraulic pressures above factory specifications.
DO NOT TAMPER WITH THIS VALVE FOR ANY REASON!!
8. Be sure there is a cutting wheel on every pin. Any pin not supported by a cutting wheel may be damaged when hydraulic pressure is applied. Do not allow wheels in upper or lower jaws to cross or contact each other.
9. If the pipe has not been cut by the time the overload valve starts to bypass excess pressure **STOP PUMPING AND RELEASE PRESSURE, NEVER APPROACH THE WORK WHILE THERE IS HYDRAULIC PRESSURE IN THE SYSTEM.**
Remove the tool from the work, and do the following:
 - a. Recheck the type, size and class of pipe being cut to be sure it is within the rated capacity of the tool.
 - b. Reinstall the tool following the instructions and safety precautions.
 - c. Repressurize the system.
 - d. If the pipe is still not cut by the time the overload valve starts to bypass, release pressure, remove the tool and place it with an authorized service center to be checked and, if necessary, adjusted or repaired.

DO NOT ATTEMPT TO ADJUST OR REPAIR THIS TOOL IN THE FIELD. SEE ENCLOSED LIST OF AUTHORIZED SERVICE CENTERS

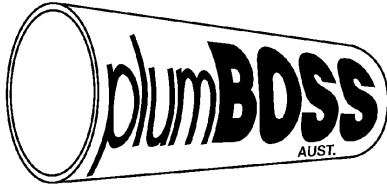

ABN: 84 568 553 950

Plumboss Australia
53 Taylor Street
(PO Box 793)
Bulimba QLD 4171
Australia

Phone: (07) 3373 3500
Fax: (07) 3373 3533

Importers and Manufacturers of Plumbing Equipment

Hydraulic Pipe Cutters

- When cutting in a line, remove excess mud, scale and rust from surface of pipe where chain wheels will make contact. This will allow wheels to contact solid pipe for maximum penetration. An excellent tool for this is the Wheeler-Rex Pipe Cleaner Model 1300 or Model 1350.
- Keep the upper jaw tie bolt tightened at all times! Operation of the cutter with this bolt loose can result in serious damage.
- Do not use brake fluid in the hydraulic system under any circumstance! It will irreparably damage the packings.
- The pump oil tank should be kept at least $\frac{3}{4}$ full.
- Repairs to hydraulic system should be made only by qualified personnel in accordance with factory specifications.
- Transportation charges must be prepaid on all units sent to service stations or to the factory for repair. If factory defect is disclosed, repaired unit will be returned to you prepaid.
- Manufacturers liability and warranties are voided if anything other than factory authorized parts are used.
- We suggest once you have established which chain pin must be engaged for a specific pipe size, that you clearly mark this pin for easy recognition (a dab of paint will do). This will facilitate quick, sure, efficient operation for all cuts of the same pipe size.
- We recommend pumping the piston all the way to the top of its stroke after each use. This will lubricate the cylinder and remove any water that has entered the cylinder. This is especially important after the unit has been used in water or under extremely dirty conditions. Release pressure so that the piston returns to a completely closed position. If necessary, apply hand pressure to return the piston back to its closed position.

Caution!!!!

Avoid standing close to either end of pipe!

The great amount of pressure exerted by the cutter may cause the cut sections to pop-off in opposite directions

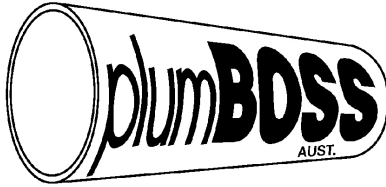

ABN: 84 568 553 950

Plumboss Australia
53 Taylor Street
(PO Box 793)
Bulimba QLD 4171
Australia

Phone: (07) 3373 3500
Fax: (07) 3373 3533

Importers and Manufacturers of Plumbing Equipment

Hydraulic Hand Pump

Wheeler-Rex Pump Model Numbers:

Model 1930 for 5590 10,000psi
Model 1830 for 3890 5,700psi
Model 1630 for 2990 9,000psi

HYDRAULIC HAND PUMP

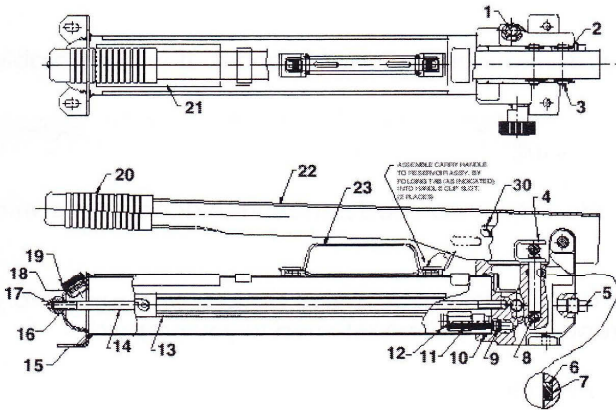

Hydraulic Hand Pump PFF-WMC

Item	Description	Wheeler #	Spx #	Qty
1	Decal	276182	215907	1
2	Retaining Ring	275795	211743	4
3	Pin	275583	211742	2
4	Piston Assembly	220843	211468	1
5	Pressure Plug	277074	11127	1
*6	Backup Washer	276154	213987	1
*7	O-Ring viton	276155	11445	1
8	Steel Ball	276157	10378	1
*9	O-Ring viton	276171	18973	1
*10	O-Ring viton	276174	213209	1
11	Filter Plug	276172	215075	1
12	Relief Valve (Red)	1857	21278-52	1
	Relief Valve (Blue)	1657	21278-86	1
	Relief Valve (Black)	1957	21278-80	1
14	Tie Rod	276178	252502	1
15	Reservoir Assembly	276176	351367	1
*16	Viton O-Ring	277075	11439	1
17	Acorn Nut	277076	10842	1
18	Viton O-Ring	277077	253597	1
19	Filler Cap	277078	351245	1
20	Handle Grip	580	580	1
22	Handle (Blue)	276149	64117BL2	1
	Handle (Red)	276151	64117RE3	1
	Handle (Black)	276150	64117BK2	1
23	Carry Handle		58048	1
25	Hydraulic Hose	3915		1

END VIEW AND SECTION A-A

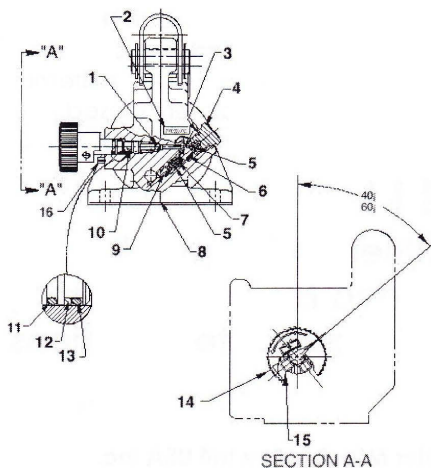

End View Parts

Item	Description	Wheeler #	Spx #	Qty
1	Ball	203197	12223	1
2	Decal	N/A		1
3	Copper Washer	276162	14874	1
4	Valve Screw	277079	351952	1
5	Compression Spring	276163	10444	2
6	Steel Ball	276157	10378	1
7	Compression Spring	276165	211797	1
8	Pump Body	276167	61295	1
9	Steel Ball	276166	10375	1
10	Release Valve Screw	275585	350185	1
11	O-Ring		14763	1
*12	Backup Washer	276161	15085	1
*13	Viton O-Ring	276160	18974	1
14	Release Valve Knob	277080	351087	1
15	Set Screw	276165	10556	1 or 2
16	Slotted Spring Screw	277081	10714	1

* Included in 1856 Repair Kit

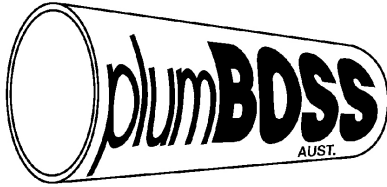

ABN: 84 568 553 950

Plumboss Australia
53 Taylor Street
(PO Box 793)
Bulimba QLD 4171
Australia

Phone: (07) 3373 3500
Fax: (07) 3373 3533

Importers and Manufacturers of Plumbing Equipment

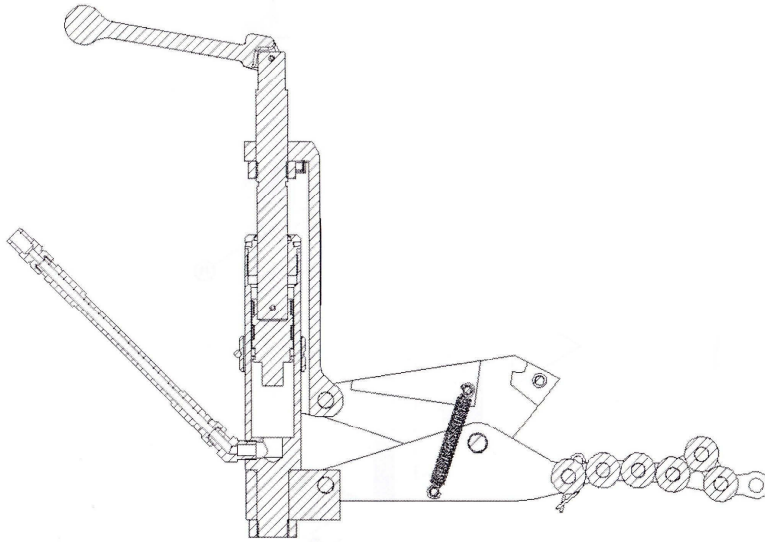
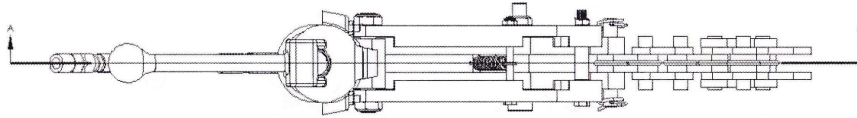

SECTION A-A

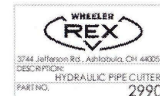

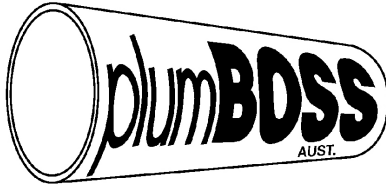

ABN: 84 568 553 950

Plumboss Australia
 53 Taylor Street
 (PO Box 793)
 Bulimba QLD 4171
 Australia

Phone: (07) 3373 3500
 Fax: (07) 3373 3533

Importers and Manufacturers of Plumbing Equipment

ITEM NO.	PART NO.	DESCRIPTION	QTY
1	221469	CYLINDER	1
2	221468	CYLINDER BOTTOM	1
3	221396	LIFTER (MACHINED)	1
4	2952	OUTER COLLAR	1
5	275830	U-BOLT	1
6	220057	BEARING	1
7	3855	HANDLE (MACHINING)	1
8	221357	PISTON ROD	1
9	2909	1 1/8", 12 NUT	2
10	729	1/4 -20 THIN HEX NYLON INSERT LOCKNUTS	4
11	700000	PISTON	1
12	275938	BACK UP RING	1
13	275939	POLY PACK	1
14	275940	WEAR RING	2
15	2910	CHEEK JAW	1
16	2911	CHEEK JAW	1
17	2928	CONNECTION STUD	1
18	2967	CONNECTION STUD	1
19	275862	3/16" DIA x 1 1/2" ROLLPIN	1
20	2927		1
21	2959	SPACER TIE BOLT LONG	1
22	275389	1/2 13 ESNA NUT	1
23	2992	5/8" x 2 3/4" SHOULDER SCREW	1
24	2939	5/16-18 x 3 1/4" HEX HEAD CAP SCREW	1
25	275857	5/16-18 THIN HEX NYLON INSERT LOCKNUTS	1
26	3908	HAIR PIN CLIP	2
27	2995	1/4-20 X 3" HEX HEAD CAP SCREW	1
28	2933	WIPER RING	1
29	2920	LOWER JAW	2
30	2904	CHAIN CONNECTING PIN	1
31	2978	SPRING. JAW EXTENSION	1
32	275542	ADAPTER PH3103-6-6	1
33	3915	HOSE	1
34	275557	ADAPTER HY-TEK 1404-6-4	1
35	***	CHAIN	1
35.1	2905	CHAIN LINK. ADJUSTING	2
36	566	9/16-12 ESNA STOP NUT	4
37	49044	3/16" x 1 1/4" SPRING PIN	1

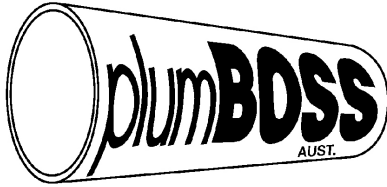

ABN: 84 568 553 950

Plumboss Australia
53 Taylor Street
(PO Box 793)
Bulimba QLD 4171
Australia

Phone: (07) 3373 3500
Fax: (07) 3373 3533

Importers and Manufacturers of Plumbing Equipment

