

Gledhill High Efficiency Condensing Boiler

Models: GB10 GB15 GB20 GB25 GB30

DESIGN, INSTALLATION AND SERVICING INSTRUCTIONS

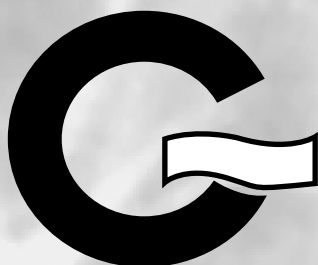

THE GAS SAFETY (INSTALLATION AND USE) REGULATIONS

**In your own interest and that of safety, it is
law that all gas appliances are installed by
competent persons and in accordance with the
above regulations.**

IMPORTANT NOTES

GENERAL

This high efficiency wall mounted condensing boiler is designed to provide central heating from a fully pumped open vented or sealed water system when coupled to a thermal store or an indirect cylinder.

The central heating water temperature can be adjusted by the installer to suit special applications.

Once the controls are set, the boiler operates automatically and the boiler controller automatically activates the frost protection program to prevent the boiler from freezing.

This boiler is for use with Natural Gas (G20) only at 20mbar inlet pressure and is for use in GB & IE only.

Appliance category: I2H
Appliance types: C13, C73, C33

These instructions cover the following boiler models and only apply to the appliances sold and installed in Great Britain (GB) and Ireland (IE).

These appliances have been certified for safety and therefore it is important these instructions must be followed. Both the appliance and the installation specifications must not be modified unless recommended and approved by Gledhill Limited in writing. Any alteration not approved by Gledhill Ltd., could invalidate the certification, boiler warranty and may also infringe the current issue of statutory requirements.

Gledhill wall mounted condensing boiler models		
Model Reference	SEDBUK Rating	Gas Council Number
GB10	90.0 % - Band 'A'	41-317-01
GB15	90.3 % - Band 'A'	41-317-02
GB20	90.4 % - Band 'A'	41-317-03
GB25	90.4 % - Band 'A'	41-317-04
GB30	90.3 % - Band 'A'	41-317-05

The Gas Safety (Installation and use) Regulations 1998

"In your own interest, and that of safety, it is law that all gas appliances are installed by competent persons, in accordance with the above regulations. Failure to install appliances correctly could lead to prosecution."



ISSUE 5: 06-08

Control of Substances Harmful to Health

When working with insulation materials, avoid inhalation as it may be harmful to health. Avoid contact with skin, eyes, nose and throat. Use disposable protection. Dampen the material and ensure that the area is well ventilated.

INSTRUCTIONS

The instructions are an integral part of the appliance and therefore read these Instructions before installing or lighting the appliance. Also to comply with the current issue of the Gas Safety (Installation and Use), these instructions must be handed to the user on completion of the installation,

It is a requirement of the Building Regulations that an approved commissioning checklist is completed by the installer. The approved Benchmark checklist is included on page 35.

Gledhill Water Storage Limited
Sycamore Estate
Squires Gate
BLACKPOOL
Lancs
FY4 3RL

CONTENTS	Page	CONTENTS	Page
1. IMPORTANT INFORMATION	4	6. COMMISSIONING	24
1.1 Gas Testing and Certification and CE Mark	4	6.1 General	24
1.2 Handling and Storing Appliance	4	6.2 Initial Lighting	24
1.3 System Installation	4	6.3 Testing - Gas	24
1.4 Warnings	4	6.4 Testing - Heating System	24
1.5 Equipment Selection	4	6.5 Testing - User Controls	24
1.6 Electricity Supply Failure	4	6.6 Frost Protection	24
1.7 Protection Against Freezing	4	6.7 Instruct the User	24
1.8 Boiler Installation in a Compartment or Cupboard	5	7. SERVICING	25
1.9 Boiler Casing	5	7.1 General	25
1.10 Condensate Drain	5	7.2 Spark & Flame Sensing Electrodes	25
1.11 Plumbing from Flue Terminal	5	7.3 Burner	25
1.12 Cleaning	5	7.4 Combustion Chamber and Heat Exchanger	25
1.13 Maintenance and Servicing	5	7.5 Condensate Drain	25
1.14 Replacement Parts	5	7.6 Inner Casing Panel Seal Check	25
1.15 Continuous Improvements	5	7.7 Combustion Check	25
2. OPERATING THE BOILER	6	8. FAULT FINDING	26
2.1 Heating System and Boiler	6	8.1 Controller Display	26
2.2 User Controls	6	8.2 Error / Fault Codes	28
2.3 To Turn the Boiler Off	7	8.3 Serial Software	29
3. INSTALLATION, DESIGN & PLANNING INFORMATION	8	8.4 Internal Wiring Diagram	32
3.1 Important Notice	8	9. REPLACEMENT OF PARTS	33
3.2 Technical Data of Boilers	9	9.1 General	34
3.3 Gas Supply	11	9.2 Spark & Flame Sensing Electrodes	34
3.4 Electricity Supply	11	9.3 Ignition & Flame Sensing Leads	34
3.5 Central Heating and Water System	11	9.4 Fan	34
3.6 System/Boiler Pump	16	9.5 Burner	34
3.7 Flow rate	16	9.6 Temperature Sensors	34
3.8 Bypass Valve	16	9.7 Heat Exchanger	34
3.9 Domestic Hot Water Storage Cylinder	16	9.8 Insulation	34
3.10 Boiler Location and Ventilation	16	9.9 Overheat Thermostat	34
3.11 Flue location and Ventilation	17	9.10 Fuses	34
3.12 Heating System Controls	18	9.11 On-Off Switch	34
3.13 Condensate Drain	18	9.12 Gas Valve	34
3.14 Water Treatment	18	9.13 Controller PCB	34
4. BOILER INSTALLATION	19	10. SPARE PARTS	38
4.1 Installation Preparation	19	11. GAS BOILER COMMISSIONING CHECKLIST	39
4.2 Hanging Bracket Fixing	19	11. TERMS & CONDITIONS OF TRADING	41
4.3 Boiler Fixing	19		
5. ELECTRICAL WIRING	21		
5.1 General	21		
5.2 External Controls	21		

IMPORTANT INFORMATION

1.1. GAS TESTING AND CERTIFICATION AND CE MARK

These boilers have been tested and certified for safety and performance. It is important that no alteration is made to the boiler unless it is approved in writing by Gledhill Ltd.

The boiler meets the requirements of Statutory Instrument No 3083 i.e. 'The Boiler (Efficiency) Regulations' and therefore it is deemed to meet the requirements of Directive 92/42/EEC. The product has been certified by the Notified body Advantica 0087 and the production is certified by the notification body BSI 0086.

The CE mark on this appliance shows compliance with:

(a) Directive 90/396/EEC on the approximation of laws relating to appliances burning gaseous fuels.

(b) Directive 73/23/EEC on the harmonisation of laws of the Member States relating to electrical equipment designed for use within certain voltage limits.

(c) Directive 89/336/EEC on the approximation of the laws of Member States relating to electromagnetic compatibility.

1.2. HANDLING AND STORING THE APPLIANCE

This appliance should be handled carefully to avoid damage and any manual handling/lifting operations will need to comply with the requirements of the Manual Handling Operations Regulations issued by the H.S.E.

During the appliance installation it will be necessary to employ caution and assistance whilst lifting as the appliance or component exceeds the recommended weight for a one man lift.

Take care to avoid trip hazards, slippery or wet surfaces. In certain situations it may be necessary to use mechanical handling aids.

If the unit needs to be stored prior to installation it should be stored upright in a dry environment and on a level base.

1.3. SYSTEM INSTALLATION

Any installation must be in accordance with the relevant requirements of the current issue of Gas Safety (Installation and Use) Regulations, Local Building Regulations, Local Water Company Bylaws and Health & Safety Document No. 635 – The Electricity at Work Regulations 1989. The detailed recommendations are contained in the current issue of the following British Standards and Codes of Practices: -

BS 5440 Pts. 1 & 2; BS 5449; BS 5546; BS 7074 Part 1; BS 6700; BS 6798; BS 6891, BS 7593, IGE/UP/7/1998

1.4. WARNINGS

(a) Gas Leak or Fault

If a gas leak or fault exists or is suspected, turn the boiler mains electricity supply off and turn off the gas supply at the meter. Consult your local gas company or your local installation/servicing company.

(b) Clearances

If fixtures are positioned close to the boiler, space must be left as shown in figure 3.10.2. Enough space must also be left in front of the boiler to allow for servicing.

(c) Sheet Metal Parts

This boiler contains metal parts (case & components) and therefore care should be taken when handling and cleaning, with particular regard to edges.

(d) Sealed Components

This boiler uses fully premix burner with air/gas ratio controller therefore the burner input i.e. CO and CO₂ settings and the burner off set pressure are factory set and sealed and require no onsite adjustments during installation or routine servicing.

Under no circumstances the user should interfere with the sealed components as this could result in a potentially dangerous situations arising. If sealed components in the appliance are replaced and/or re-commissioned in the field then these must be done strictly in accordance with manufacturer's instructions and these components must be re-sealed.

(e) Bench Mark Log Book

As part of the industry wide 'Benchmark' initiative all Gledhill appliances now include a Benchmark Installation, Commissioning and Service Record Logbook. Please read this carefully and complete all sections relevant to this appliance. Failure to do so may affect warranty.

1.5. EQUIPMENT SELECTION

This information is provided to assist generally in the selection of equipment. Responsibility for selection and specification of our equipment must, however, remain that of our customers and any expert or consultants concerned with the installation(s). Therefore please note that: -

(a) We do not therefore accept any responsibility for matters of design selection or specification for the effectiveness of an installation containing one of our products.

(b) All goods are sold subject to our Conditions of Sale, which are set out in the Appendix to this document.

1.6. ELECTRICITY SUPPLY FAILURE

(a) This boiler must be earthed and the boiler will not work without an electricity supply.

(b) Reset any external controls to resume normal operation of the central heating.

(c) Normal operation of the boiler should resume when the electrical supply is restored. If the boiler does not resume normal operation turn the mains switch off and on. If the boiler does not resume normal operation after this, the overheat thermostat may have operated. The overheat thermostat would only operate under abnormal conditions and, under these circumstances it would be advisable to consult your installation/servicing company.

1.7. PROTECTION AGAINST FREEZING

(a) The boiler has built in frost protection programme as long as the electricity and gas are left switched on. The boiler controller operates the burner and the system pump when the temperature inside the boiler falls below 5°C.

(b) Any other exposed areas of the heating and hot water system should be protected by a separate frost thermostat.

(c) If the mains electricity and gas supplies to the boiler system are to be turned off for any long periods during severe weather, it is recommended that the whole system including the boiler should be drained to avoid risk of freezing. In this case ensure that the immersion heater in the cylinder if fitted is switched off.

(d) If you have a sealed heating system, contact your installation/service company as draining, refilling and pressurising MUST be carried out by a competent person.

(e) As a safety feature, the boiler will stop working if the condensate drain becomes blocked. During freezing conditions this may be due to the forming of ice in the condensate drain external to the house. Release ice blockage by use of warm cloths on the pipe. Contact your installation/service company if the fault persists.

1.8. BOILER INSTALLATION IN A COMPARTMENT OR CUPBOARD

If the boiler is fitted into a compartment or a cupboard, it does not require ventilation openings. However, do not use the compartment or cupboard for storage.

1.9. BOILER CASING

Do not remove or adjust the casing in any way, as the incorrect fitting may result in incorrect operation or failure to operate at all.

1.10. CONDENSATE DRAIN

The condensate drain must not be modified or blocked (See section 3.13)

1.11. PLUMING FROM FLUE TERMINAL

This is a high efficiency-condensing boiler and hence flue gas temperature will be low. Therefore like all condensing boilers this appliance will produce a plume of condensation in cool weather. It is normal and not a fault condition, but this should be taken into account when positioning the boiler.

1.12. CLEANING

This boiler contains metal parts and therefore care should be taken when handling and cleaning, with particular regard to edges.

The boiler casing can be cleaned using a mild liquid detergent with a damp cloth and then a dry cloth to polish. Do not use any form of abrasive or solvent cleaner as you may damage the finish.

1.13. MAINTENANCE AND SERVICING

This appliance must be serviced and installed by a competent person e.g. CORGI Registered installer. All CORGI registered installers carry a CORGI ID Card and have a registration number. You can call CORGI direct on 01256 372300.

For the continued efficient and safe operation of the boiler, it is recommended that it is checked and serviced at regular intervals. The frequency of service will depend upon the installation condition and usage, but in general, once a year should be enough.

If this boiler is installed in a rented property, there is a duty of care imposed on the owner of the property by the current issue of the Gas Safety (Installation and Use) regulations, Section 35.

The installation / service engineer should complete the 'Benchmark' logbook on completion of commissioning and service work.

1.14. REPLACEMENT PARTS

When replacing spare parts on this appliance, remember to use only spare parts that you can be assured to conform to the safety and performance specification that we require. Do not use reconditioned or copy parts that have not been clearly authorised by Gledhill Ltd.

Free of charge replacement for any faulty components are available from Gledhill Ltd during the in-warranty period (normally 12 months).

After this the spares can be obtained direct from Gledhill Ltd using the 'Speed Spares' service. Help and advice is also available from our Technical Help Line on 08449 310000.

Please quote the name and model of the appliance when requesting for help or ordering spares. This information will be on the front of the appliance next to the main switch.

1.15. CONTINUOUS IMPROVEMENTS

In the interest of continuously improving the Gledhill Boiler range, Gledhill Water Storage Ltd reserves the right to modify the product without notice and in these circumstances this booklet, which is accurate at the time of printing, should be disregarded.

OPERATING THE BOILER

2.1. HEATING SYSTEM AND BOILER

(a) Sealed Systems

A sealed heating system must be filled and pressurised by a competent person. Only light the boiler when you are sure that the system and the boiler have been filled and pressurised.

The pressure should read at least 0.5bar, anything less than this figure could indicate a leak and you MUST contact your installation / servicing company.

(b) All Systems

Check that the electrical supply to the boiler is ON at the external system isolator. Set any remote controls as required.

This is a fan flued appliance and therefore the fan operation may be heard. The boiler flow temperature is factory set at 77°C and is not user adjustable. (Note: The boiler flow temperature can be adjusted between 55°C and 85°C by the installer for special applications)

- If the boiler fails to ignite, the dot D1 will switch off and dot D2 will be flashing or be on constantly (depending upon the error type) and reset will be required.

- When the demand for boiler firing stops i.e. heat is not required for space heating or hot water, the boiler will stop firing and this will be indicated by flashing dot D1 and bar a2 will switch off. After a period of about 3 minutes the boiler pump will switch off indicated by bar a1.

(b) To Reset Boiler

Press reset button S1. If the dot D1 starts to flash and the dot D2 switches off, the boiler has reset. If the fault persists contact your installer/service provider.

2.3. TO TURN THE BOILER OFF

Turn the mains /reset switch to the off position (indicated by disc). Turn the gas supply off at the gas service cock if the boiler is to be out of use for some time.

Diagram 2.1

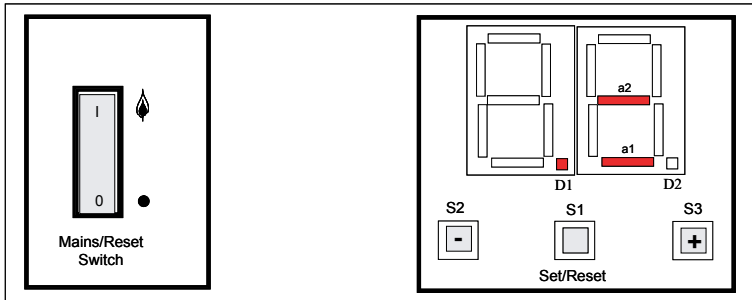

2.2. USER CONTROLS

The appliance control panel is shown in diagram 2.1. The appliance on-off switch should be left in the ON position (indicated by flame symbol) for normal operation otherwise the built in boiler frost protection will not function.

The two-digit display indicates the status of the boiler and the push buttons are used for setting and resetting the controller as shown in diagram 2.2.

(a) Central heating and hot water

- Switch the boiler on-off switch to position 'ON' position indicated by a 'flame' symbol and the dot D1 will begin to flash to indicate that the boiler controller is active.

- Set the remote user controls e.g. programmer and room thermostat so that hot water heating and/or central heating demands are active.

- When the boiler senses the heating demand, indicated by horizontal bar 'a2', the boiler switches on the boiler pump (indicated by bar 'a1') and starts the boiler firing sequence.

- When the boiler has lit, the dot D1 will stop flashing and will be on constantly.

Diagram 2.2 Boiler display indication

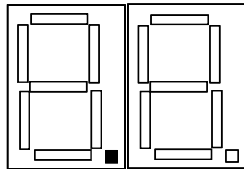

D1 flashing
D2

- Controller on standby
- Boiler off

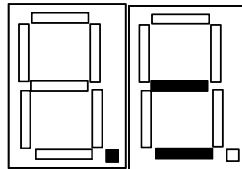

D1 flashing
D2

- Boiler in ignition sequence/
boiler control thermostat satisfied
- Boiler heat demand present
- Boiler pump on

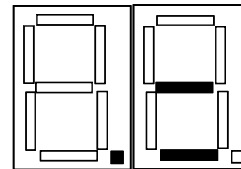

D1 ON
D2

- Boiler has lit
- Boiler heat demand present
- Boiler pump on

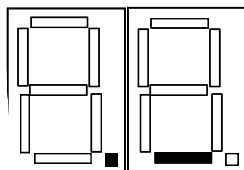

D1 flashing
D2

- Boiler off
- Heat demand not present
- Boiler pump overrun on

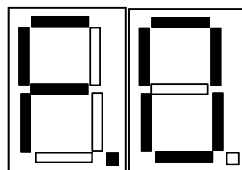

D1 flashing
D2

- Frost protection program F0 on
- Boiler pump on

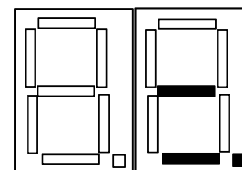

D1 flashing
D2 On/flashing

- Boiler blocking/lockout error
- Reset required

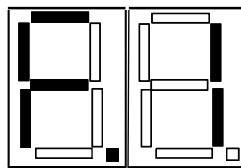

On

- Frost protection program F1 on
- Boiler pump on
- Boiler burner is on

INSTALLATION DESIGN AND PLANNING INFORMATION

3.1. IMPORTANT NOTICE

(a) The boiler is supplied in one pack. The flue and fixing jig are supplied separately.

(b) This boiler is for use on G20 natural gas only. The boiler is certified to the current issue of EN483 for performance and safety. It is important that no alteration is made to the boiler, without written permission of Gledhill Ltd.

(c) Where no British Standards exist, materials and equipment should be fit for their purpose and of suitable quality and workmanship.

(d) The installation of this boiler must be carried out by a competent person e.g. CORGI Registered installer, must comply with the relevant requirements of :-

Manufacturer's instructions supplied

- The Gas Safety (Installation and use) Regulations,
- The Building Regulations and local Water Company Bylaws. The Health and Safety at Work Act, Control of Substances Hazardous to Health, The Electricity at Work Regulations and any other applicable local regulations.
- The detailed recommendations are contained in the current issue of BS 5440 Pts. 1 & 2; BS 5449; BS 5546; BS 7074 Part 1; BS 6700; BS 6798; BS 6891, BS 7593, IGE/UP/7/1998

(e) When installing the boiler, care should be taken to avoid any possibility of personal injury when handling sheet metal parts.

(f) Refer to Manual Handling Operations, 1992 regulations.

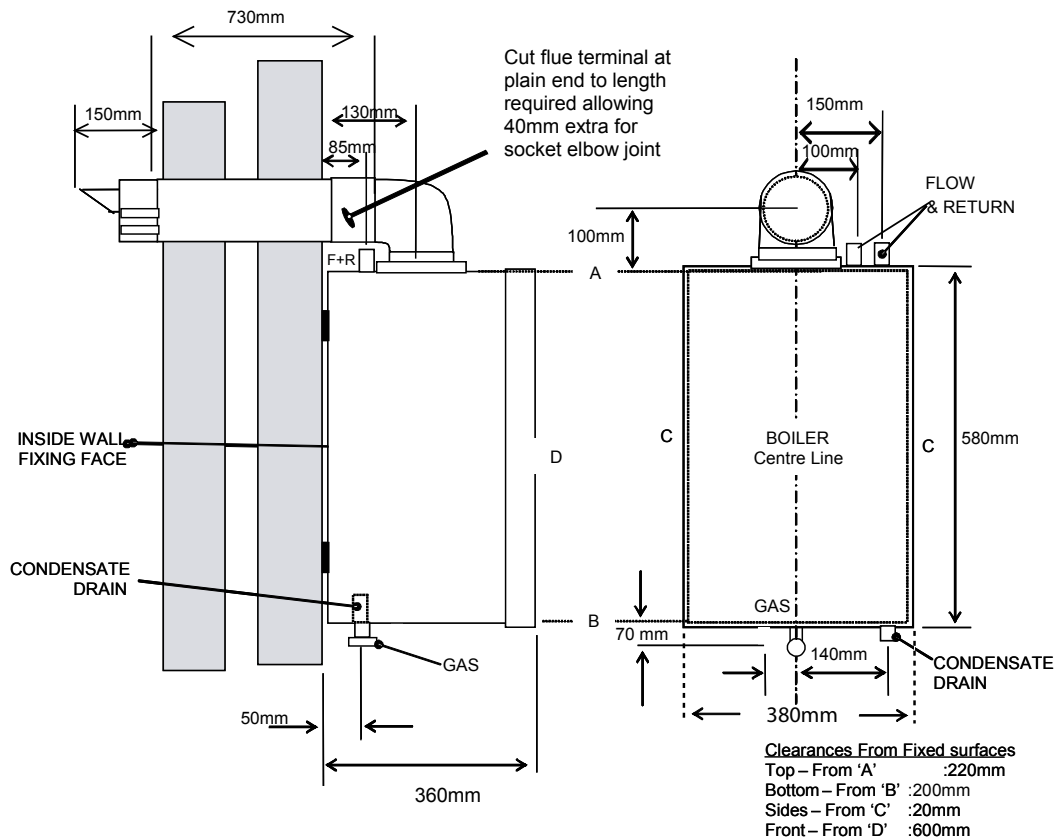

Diagram 3.1 Boiler Models GB30, GB25, GB20

INSTALLATION DESIGN AND PLANNING INFORMATION

3.2. TECHNICAL DATA OF BOILERS

The main dimensions and the clearances required for the boilers are shown in diagram 3.1 for models GB30, GB25 and GB20 and diagram 3.2 for models GB15 and GB10. The technical data of the boilers is shown in tables 3.1 and 3.2. The boiler data badge is positioned on the inner door.

The Seasonal Efficiency Domestic Boilers UK (SEDBUK) of Gledhill Boilers (all models) is Class 'A'. The values used in the UK Government's Standard Assessment Procedure (SAP) for energy rating of dwellings. The test data from which it has been calculated has been certified by Advantica.

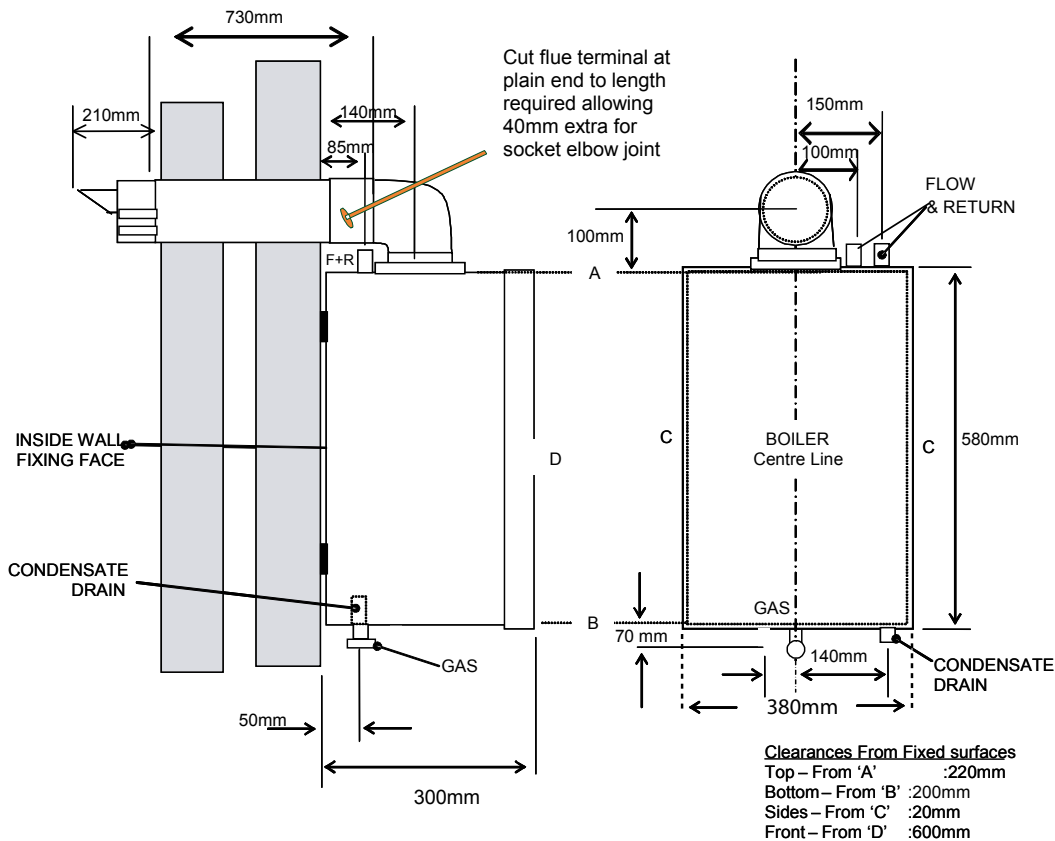

Diagram 3.2 Boiler Models GB10 and GB15

INSTALLATION DESIGN AND PLANNING INFORMATION

Table 3.1. Connection, Electrical and Weight data of the boiler			
		Boiler Model	
		GB30,GB25,GB20	GB15,GB10
Overall dimensions including flue spigot	Height (mm)	580	580
	Width (mm)	380	380
	Depth (mm)	360	300
Clear space required for installation	Height (mm)	1000	1000
	Width (mm)	420	420
	Depth (mm)	500	440
Weight	(kg)	29.5	24.5
Water content	(litres)	1.5	1
Working pressure (m wg / (bar))	Minimum	1.0/(0.1)	1.0/(0.1)
	Maximum	30.0/(3.0)	30.0/(3.0)
Connections	Gas	Rc1/2, (1/2in BSP)	Rc1/2, (1/2in BSP)
	Water	22mm copper	22mm copper
	Condensate Drain	22mm plastic pipe	22mm plastic pipe
Electrical data	Electricity supply	230V, ~50Hz Fused at 3A	230V, ~50Hz Fused at 3A
	Electrical rating	60W @230V ac	60W @230V ac
	Internal fuse rate	Main PCB 3.15AT	Main PCB 3.15AT

Table 3.2. Thermal, combustion and gas data						
	Rating	Boiler Model				
		GB30	GB25	GB20	GB15	GB10
Gross heat input (kW)	Maximum	34.2	28.3	22.6	17.0	11.4
	Minimum	10.0	8.5	6.8	5.1	4.6
Net heat input, Q (kW)	Maximum	30.8	25.5	20.4	15.3	10.3
	Minimum	9.0	7.7	6.1	4.6	4.1
Heat output, P Non condensing (kW)	Maximum	30.2	25.0	20.0	15.0	10.0
Heat output Condensing mode (kW)	Maximum	32.0	27.2	22.0	16.4	10.84
	Minimum	9.8	8.4	6.6	4.9	4.4
Burner CO ₂ (%) at maximum rate	Case off	9.0 - 9.6	9.0 - 9.6	9.0 - 9.6	8.8 - 9.4	9.0 - 9.6
	Case on	9.2 - 9.8	9.2 - 9.8	9.2 - 9.8	9.0 - 9.6	9.2 - 9.8
Approximate Gas rate (m ³ /h) - After 10min from cold	Maximum	3.3	2.7	2.2	1.6	1.1
Off-set pressure at minimum rating (Pa)		- 8.0	-10.0	-10.0	-8.0	-6.0
Minimum water flow rate (m ³ /h)		1.37	1.17	0.94	0.70	0.48

3.3. GAS SUPPLY

- (a) The Local Gas Supplier should be consulted at the installation planning stage in order to establish the availability of an adequate supply of gas.
- (b) An existing service pipe **MUST NOT** be used without prior consultations with the gas supplier.
- (c) A gas meter can only be connected by the Local Gas Supplier or by his Contractor.
- (d) An existing meter should be of sufficient size to carryout the maximum boiler input plus the demand of any other installed gas appliance, (BS 6891:1988). The supply from governed meter must provide steady inlet working pressure of 20mbar (8in wg) at the boiler. See section Technical Data for the gas required for each specific model.
- (e) The gas supply line must be purged. **WARNING:** before purging open all doors and windows and also extinguish any cigarettes, pipes and any other naked lights.
- (f) The complete gas installation must be tested.

3.5. CENTRAL HEATING AND WATER SYSTEM

The Gledhill boiler is suitable for use with both vented and unvented traditional heating systems and also for use with the thermal storage systems e.g. Gledhill BoilerMate OV and Gledhill BoilerMate SP (SysteMate).

Plastic Pipes

When plastic pipe is to be used for the heating system, this must be suitable for the maximum pressures and temperatures for the intended application. The class 'S' pipes and fittings are defined in BS 7279-1.

Some plastics are permeable to the oxygen and to prevent corrosion of system components (e.g. heat exchanger) due to build up of oxygen, a barrier type pipe must be used i.e. pipes incorporating a polymer barrier layer.

When plastic pipe is used, the first 2m of pipe work from the boiler (both flow and return) must be in copper.

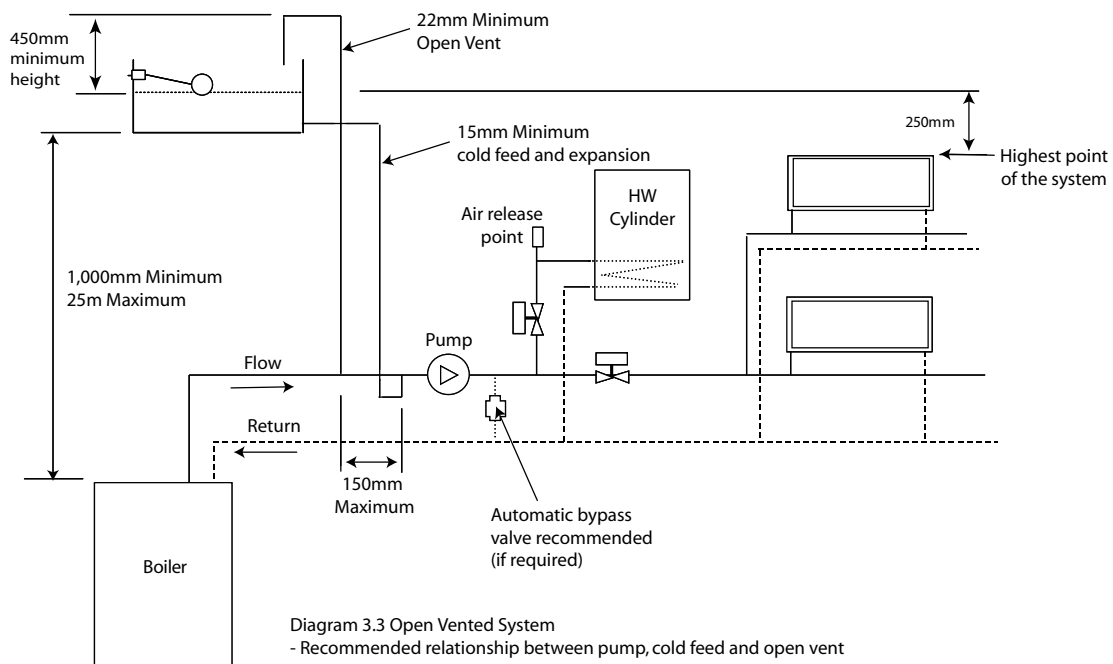

3.4. ELECTRICITY SUPPLY

- (a) The boiler must be permanently connected to a 230V~, 50Hz supply. This appliance **MUST BE EARTHED**.
- (b) All external wiring to the boiler must be in accordance with the latest I.E.E. Wiring Regulation, and any local regulations, which may apply.
- (c) There must be only one common isolator for the boiler and its control system, and it must provide complete electrical isolation via a double pole isolator fused at 3A maximum with a contact separation of at least 3mm in both poles.
- (d) The fused spur box should be readily accessible and preferably adjacent to the appliance and it should be identified as to its use.
- (e) Alternatively the connection can be made through an unswitched shuttered socket and 3A fused 3-pin plug both to the current issue of BS 1363 may be used, provided they are not used in a room containing bath or shower.
- (f) In the event of an electrical fault after installation of the appliance, preliminary electrical checks must be carried out i.e. Earth Continuity, Short Circuit, Polarity, and Resistance to Earth.

INSTALLATION DESIGN AND PLANNING INFORMATION

3.5.1. Open vented heating system

(a) The open i.e. vented heating system is shown schematically in diagram 3.3. It is important that the relative positions of the pump, cold feed and the open vent are as shown in diagram 3.3 to minimise the chances of air ingress and pump over conditions arising.

(b) The cold feed must be 15mm minimum size. The 22mm (minimum) open vent must rise continuously and be unrestricted.

(c) The boiler must be supplied from an unrestricted water supply taken from feed and expansion cistern situated at a maximum height of 30 meters above the boiler.

(d) A safety valve need not be fitted to an open vented heating system.

(e) A draining tap conforming to the current issue of BS 2879, must be provided at the lowest point of the system, which will allow the entire central heating and hot water system to be drained.

(f) The overflow/warning pipe should be in 20mm internal diameter pipe of suitable material for use in heating systems in accordance with BS 5449 (such as copper). It should have continuous fall and discharge in a conspicuous external position. It should not have any other pipework directly branched into it.

(g) The water level in the F & E cistern should be at least 250mm above the highest point on the system including the radiators

3.5.2. Sealed heating system

(a) Design Standards

The sealed heating system is shown schematically in diagram 3.4. The sealed system installation must comply with the appropriate requirements of current issues of BS5449, BS6759, BS6798 and BS7074.

(b) Safety Valve

A non-adjustable safety valve must be fitted to a sealed system. It shall be pre-set with a lift pressure of 3 bar and incorporate a seating of resilient material, a test device and a connection to the drain

(c) Safety Valve Drain

The drain from a safety valve must be routed outside the building and positioned so that any discharge can be seen. It must not discharge above an entrance or window or any type of public area and be clear of any electrical fittings.

(d) Pressure Gauge

A pressure gauge with a set pointer and covering at least 0 – 4 bar shall be fitted permanently to the sealed system. It should be positioned where it can be seen when filling the system.

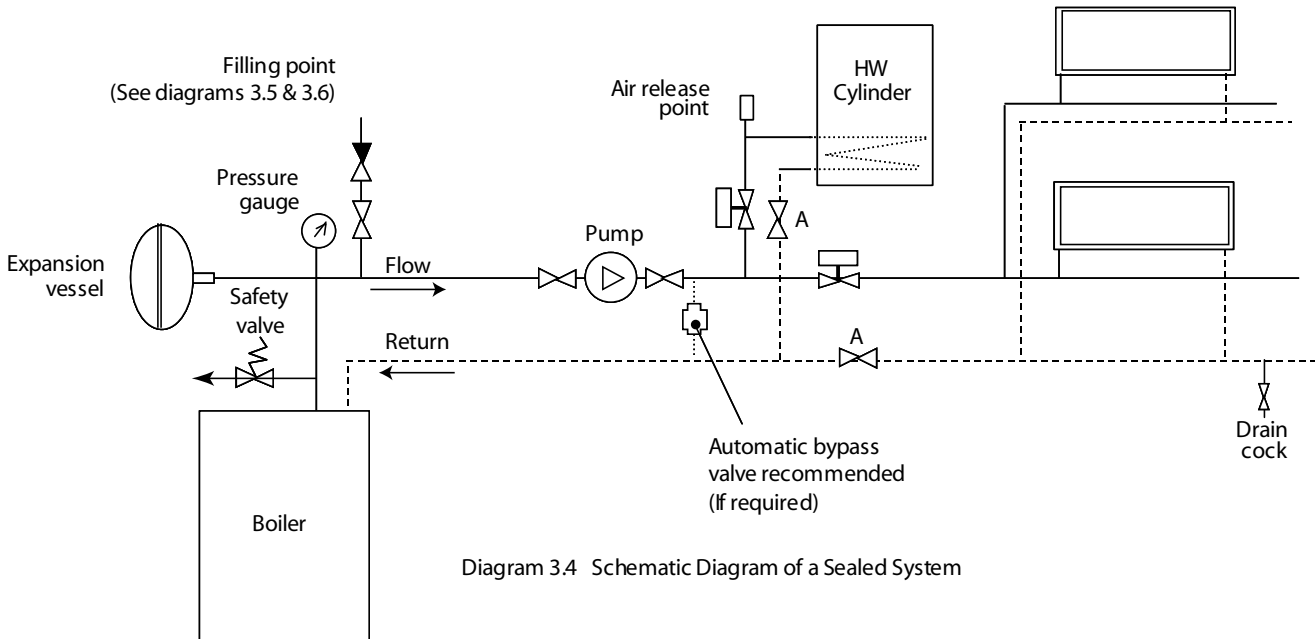

Diagram 3.4 Schematic Diagram of a Sealed System

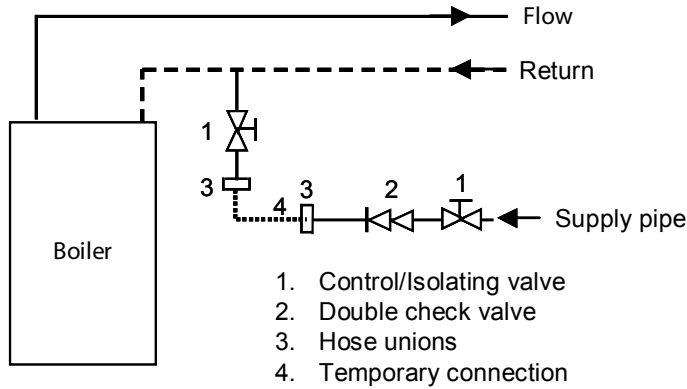

Diagram 3.5 Sealed system filling method 1

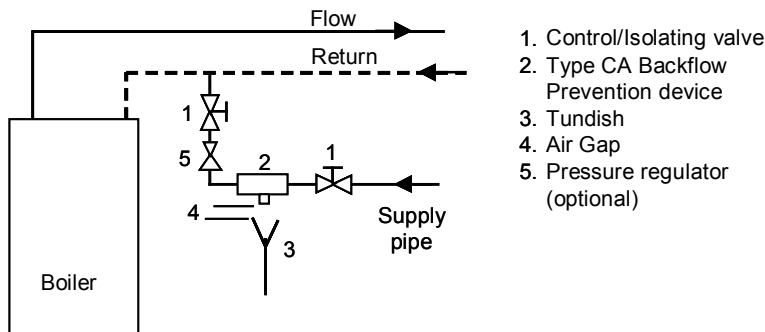

Diagram 3.6 Sealed system filling method 2

3.5.2. Sealed heating system(Cont)

(e) Expansion Vessel

A diaphragm type expansion vessel, conforming to the current issue of BS4814 (See also BS7074 Parts 1 and 2) must be connected to the inlet side of the circulating pump (see diagram 3.4) unless laid down differently by the manufacturer.

The water content of the boiler is given in table 3.1.

The expansion vessel volume depends on the total water volume of the system and the initial system design pressure as shown below in table 3.3. For any system an accurate calculation of vessel size is given in the current issue of BS5449 and BS7074 Part 1. For example; A higher initial design charge pressure requires a larger volume vessel.

The initial vessel charge pressure must not be less than the static head of the system, that is the height of the highest point of the system above the expansion vessel.

(f) Water Makeup

Provision should be made for replacing the water loss from the system using a makeup bottle mounted in a position higher than the highest point of the system, connected through the non-return valve to the return side of either central heating or hot water cylinder circuit.

Alternatively, provision for water makeup can be made using a filling loop, in an accessible position on the return, or an approved CA device as discussed below.

(g) Filling a Sealed Heating System

Provision for filling a sealed system at low level must be made and the method selected must comply with the Water regulations. The temporary filling loop method is shown in diagram 3.5 and the CA-device method is shown in diagram 3.6.

The CA device normally requires a pressure differential to operate and this should be taken into account when selecting the device and the system operating pressures.

For the temporary filling loop method there must be no permanent connection to the mains supply, even through a non-return valve.

Table 3.3 Expansion vessel volume required

Safety valve setting (bar)	3.0								
	0.5			1.0			1.5		
Vessel charge pressure (bar)	0.5	1.0	1.5	2.0	1.0	1.5	2.0	1.5	2.0
Initial system fill pressure (bar)	0.5	1.0	1.5	2.0	1.0	1.5	2.0	1.5	2.0
Total system water content (l)	Expansion vessel volume (litres)								
25	2.1	3.5	6.5	13.7	2.7	4.7	10.3	3.9	8.3
50	4.2	7.0	12.9	27.5	5.4	9.5	20.6	7.8	16.5
75	6.3	10.5	19.4	41.3	8.2	14.2	30.9	11.7	24.8
100	8.3	14.0	25.9	55.1	10.9	19.0	41.2	15.6	33.1
125	10.4	17.5	32.4	68.9	13.6	23.7	51.5	19.5	41.3
150	12.5	21.0	38.8	82.6	16.3	28.6	61.8	23.4	49.6

INSTALLATION DESIGN AND PLANNING INFORMATION

3.5.3. Gledhill BoilerMate OV Heating System

The Gledhill Boiler is also suitable for use with a Gledhill BoilerMate OV; an integrated open vented heating system and mains pressure hot water appliance. This appliance is supplied with factory fitted and wired system controls and equipment e.g. pumps, valves etc. The BoilerMate OV uses a directly heated open vented primary store and is suitable for only vented heating systems as shown schematically in diagram 3.7. For further details refer to Gledhill BoilerMate OV manual.

The BoilerMate OV acts as the neutral point of the system and therefore the cold feed and open vent must be piped to the appropriate connections on the BoilerMate OV.

A draining tap conforming to the current issue of BS 2879, must be provided at the lowest point of the system, which will allow the entire central heating and hot water system to be drained.

The overflow/warning pipe should be in 20mm internal diameter pipe of suitable material for use in heating systems in accordance with BS 5449 (such as copper). It should have continuous fall and discharge in a conspicuous external position. It should not have any other pipework directly branched into it.

The height of the F & E cistern above the BoilerMate OV should not be greater than 10m and the water level in the F & E cistern should be at least 450mm above the highest point on the system including the radiators

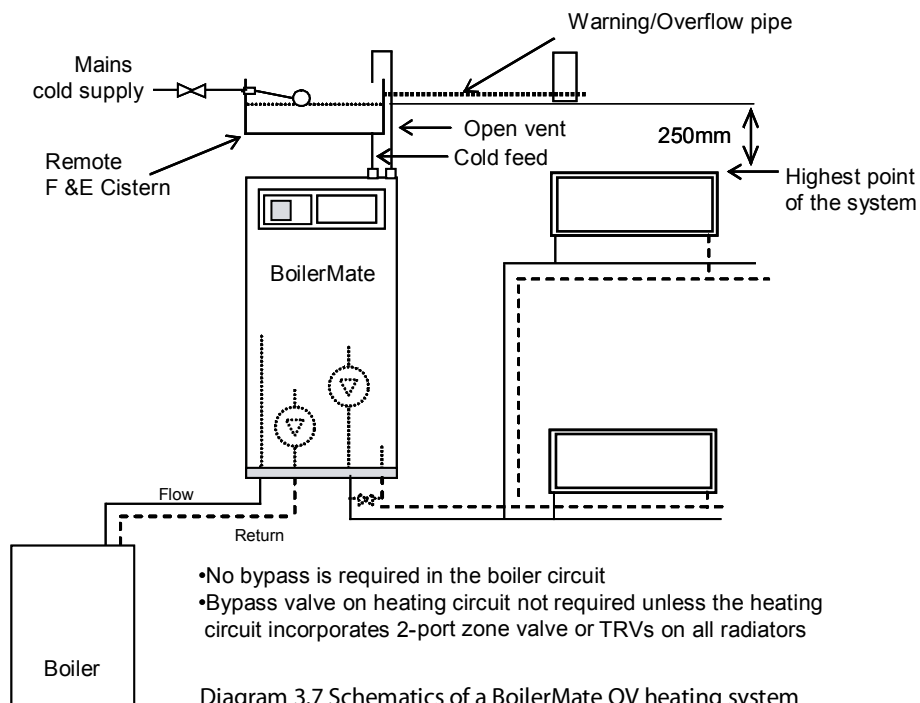

3.5.4. Gledhill BoilerMate SP Heating System

The Gledhill Boiler is also suitable for use with a Gledhill BoilerMate SP; an integrated sealed heating system and mains pressure hot water appliance. The BoilerMate SP uses an indirectly heated open vented hot water only primary store. The central heating circuit is suitable for sealed heating systems as shown schematically in diagram 3.8. For further details refer to Gledhill BoilerMate SP manual.

When using the boiler with a BoilerMate SP, the pressure safety valve must be fitted on the boiler flow pipe adjacent to the boiler. The expansion vessel should be fitted adjacent to the BoilerMate SP and connected to the connector on the top of the BoilerMate SP.

The sealed central heating system design and component selection and sizing including filling arrangements should follow the guidelines discussed in section 3.5.2 'Sealed Heating Systems'.

Although the heating system is sealed, the primary store in the BoilerMate SP must be filled via a feed and expansion cistern supplied with the appliance as shown in diagram 3.8. The height of the F & E cistern above the BoilerMate SP should not be greater than 10m.

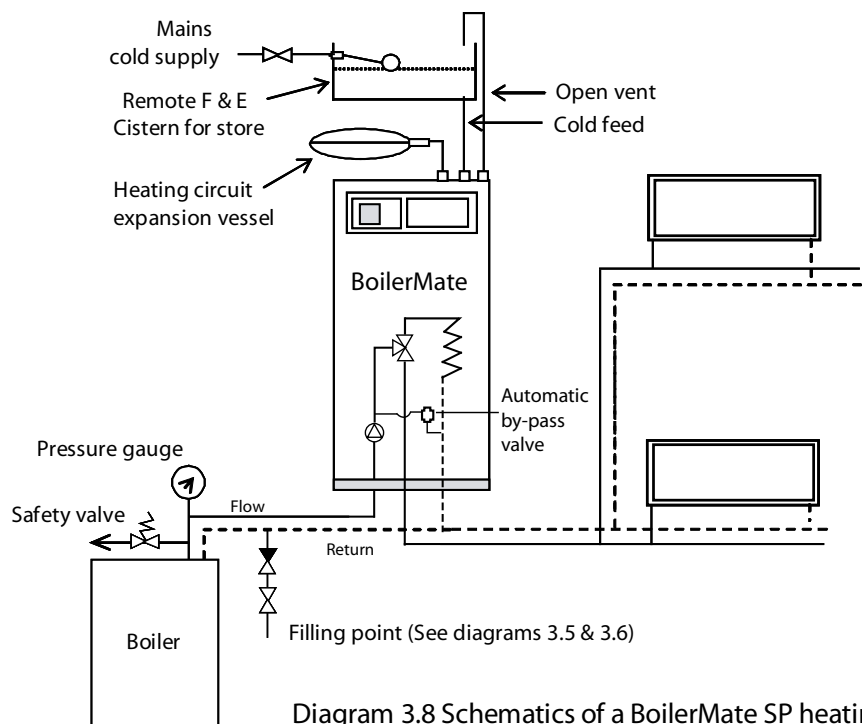

Diagram 3.8 Schematics of a BoilerMate SP heating system

INSTALLATION DESIGN AND PLANNING INFORMATION

3.6. SYSTEM / BOILER PUMP

The variable duty pump should be fitted on the flow pipe from the boiler and have isolating valves on each side as shown schematically in diagrams 3.3 and 3.4.

The pressure loss characteristics of the boilers are shown in diagram 3.9. The water flow rates and the boiler pressure losses at 11°C and 20°C temperature differences are also tabulated below in table 3.4.

The variable duty pump should be set to give a temperature difference of no greater than 20°C between boiler flow and return to give minimum flow rate through the boiler shown in table 3.4. High resistance micro bore systems may require a higher duty pump.

Diagram 3.9 Pressure loss characteristics of the boilers

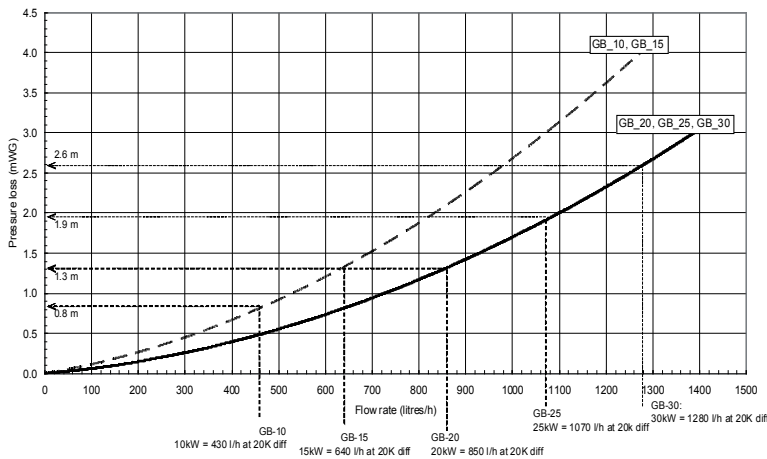

3.7. FLOW RATE

If it is necessary to alter the flow rate in a system, the system can be fitted with a lockable balancing valve in the main flow or return pipes. The example is shown as a valve 'A' in diagram 3.4.

The flow rate through the boiler must not be allowed to fall below the values given in table 3.2 for the boiler model selected.

Table 3.4 Boiler pressure loss data			
Boiler Model	Temperature difference (K)	Flow rate (Litres per hour)	Pressure loss (m WG)
GB30	11	2342	6.66
	20	1288	2.30
GB25	11	1951	4.79
	20	1073	1.69
GB20	11	1561	3.22
	20	858	1.17
GB15	11	1171	3.91
	20	644	1.47
GB10	11	780	2.00
	20	429	0.80

3.8. BYPASS VALVE

A bypass is not required on the central heating system unless the system controls could allow the boiler and the pump to operate when there is no flow.

When a bypass valve has to be fitted, it must be placed at least 1.5 meters away from the boiler as shown schematically in diagrams 3.3 and 3.4. An automatic bypass valve is recommended.

3.9. DOMESTIC HOT WATER STORAGE CYLINDER

Single feed indirect cylinders are not suitable.

The domestic hot water cylinder must be of the double feed fully indirect coil type. It must be suitable for working at a gauge pressure of 0.35 bar above the safety valve setting.

The storage vessel does not have a vent to the atmosphere i.e. unvented cylinder is used, then the installation must comply with the Building regulations and Local Water Company bylaws. See also the current issues of BS5546 and BS6700.

3.10. BOILER LOCATION AND VENTILATION

3.10.1. Boiler Location

The boiler may be installed in any room although particular attention is drawn to the requirements of the current issue of BS7671 with respect to the installation of a boiler in a room containing a bath or a shower.

Any electrical switch or boiler control using mains electricity supply should be so sited that a person using the bath or a shower cannot touch it. The electrical provisions of the Building Standards (Scotland) Regulations are applicable to such installations in Scotland.

These boilers are not suitable for fitting outdoors. The boiler must be mounted on a flat wall, which is sufficiently robust to take its total weight given in table 3.1.

INSTALLATION DESIGN AND PLANNING INFORMATION

3.10.2. Clearances

The boiler should be positioned and installed so that at least minimum clearances shown in diagram 3.10, required for servicing and correct operation are provided. Additional clearances may be useful around the boiler for installation and servicing.

For flue installations where external access is not practical, considerations should be given for the space required to insert the flue internally, which may require clearances larger than those specified in diagram 3.10.

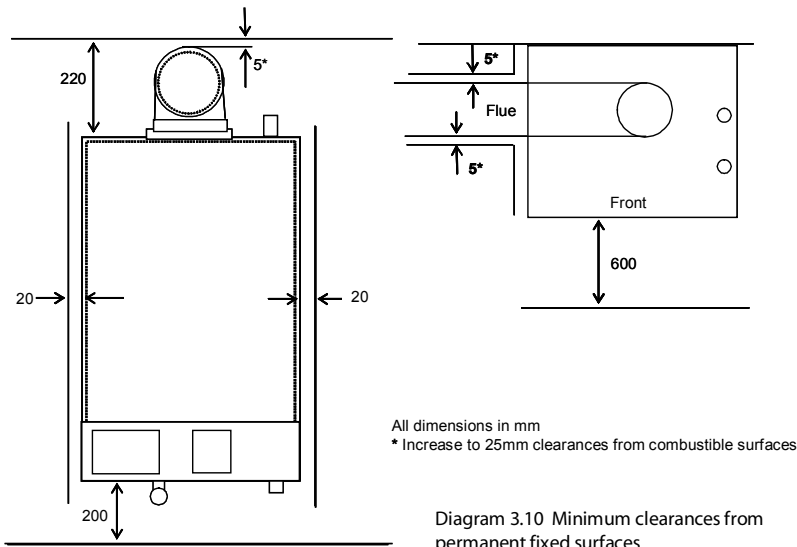

3.10.3. Timber Frame Buildings

If the boiler is to be installed in a timber frame building, it should be fitted in accordance with the Institute of Gas Engineers document IGE/UP/7/1998. If in doubt, ask local gas utility company or Gledhill Ltd.

3.10.4. Room ventilation

The boiler is room sealed, so when it is installed in a room or space, a permanent air vent is not required.

3.10.5. Compartment ventilation

If the boiler is installed in a compartment, a permanent air vent is not required. However leave existing air vents.

3.11. FLUE LOCATION AND VENTILATION

3.11.1. Flue Position and Length

The standard horizontal flue is fitted onto the top of the boiler as shown in diagrams 3.11 and 3.12. The dimension "X" for the rear outlet flue and dimension "Y" for the side outlet flue must be measured and compared against the standard flue supplied to check if it is suitable.

An extended flue system can be installed with the addition of extension kits (see section 3.11.3 Flue options). The flue system must always be designed and installed to have a continuous fall towards the boiler of at least 3° to allow the condensate to run to drain via the boiler.

3.11.2. Internal Flue Installation

The flue can be installed from inside the building when access to the outside wall face is not practical.

3.11.3. Flue Options

The concentric flue systems and kits available for this boiler are listed below in table 3.4. Additional accessories and flue systems are also available for this boiler. See 'Gledhill Boiler Flue Options Guide' for configurations that are available.

Description	Part No.
Standard horizontal flue kit	GT461
Vertical flue terminal kit – pitched	AFB001
Flat roof flue kit	AFB010
Ridge terminal flue kit	AFB020

The concentric flue system can be extended to a maximum equivalent length of 6.65 metres (excluding flue terminal) after the flue elbow fitted to the appliance. This can be horizontal or vertical but the following allowances should be made for each component fitted.

Description	Equivalent Length
2m Flue extension	2.0
1m Flue extension	1.0
0.5m Flue extension	0.5
45° Flue bend	1.5
90° Flue bend	1.9

INSTALLATION DESIGN AND PLANNING INFORMATION

3.11.4. Terminal Position

The minimum acceptable siting dimensions for the terminal for obstructions, other terminals and ventilation openings are shown in Gledhill Boiler Flue Options Guide. The dimensions measured are from the edge of the terminal.

The terminal must be exposed to the external air, allowing passage of air across it at all times.

This is a condensing boiler and therefore some plumbing may occur from the flue outlet. This should be taken in to consideration when selecting the position for the terminal.

Carports or similar extensions of roof only, or roof and one wall, require special consideration with respect to any openings, doors, vents or windows under the roof. Care is required to protect the roof if it is made of plastic sheeting. If the carport has a roof and two or more walls, then seek advice from the local gas supply company before installing a boiler.

3.11.5. Terminal Guard

A terminal guard is required if a person could come into contact with the terminal or the terminal could be subject to damage. The terminal guard is required for horizontal flue terminals below 2m above the ground floor or accessible by the general public from the windows, balconies etc.

If a terminal guard is required, it must be positioned to provide minimum of 50mm clearance from any part of the terminal and be central over the terminal.

A terminal guard for this boiler is shown in the Gledhill Boiler Flue Options Guide and is available from Gledhill Ltd quoting part number GF199.

3.12. HEATING SYSTEM CONTROLS

It is recommended that a programmer and a room thermostat should control the boiler when there is a demand for central heating and a programmer and hot water store thermostat should control the boiler when there is a demand for water heating.

The thermostatic radiator valves may be installed; however they must not be fitted in a room where the room thermostat is located. (Note: All systems must have at least one radiator that is not fitted with a thermostatic valve.)

The heating system controls must meet the requirements of the current issue of the Building Regulations. For further information see:-

- The current issue of "Approved Document L1 – Conservation of fuel and power in dwellings"
- GIL 59, 2000 : Central heating system specification (CheSS)
- GPG 302, 2001: Controls for domestic central heating system and hot water. BRECSU.

3.13. CONDENSATE DRAIN

A plastic drainpipe must be fitted to the boiler to allow discharge of condensate to the suitable drain. A copper pipe is **NOT** suitable.

Condensate should, if possible, be discharged into the internal household drainage system. If this is not practical, discharge can be made externally into the household drainage system or a purpose designed soak away. See section 4 for further details.

Note: Condensate trap inside the boiler casing must be manually filled with water after installing the boiler (i.e. before the first firing) and before commissioning the system.

For long-term corrosion protection, after flushing, an inhibitor suitable for stainless steel heat exchangers should be used. Refer to the current issue of BS5449 and BS7593 on the use of inhibitors in central heating systems. The examples are Sentinel X100 and Fernox MBI.

3.14. WATER TREATMENT

In the case of an existing installation, the system MUST be thoroughly flushed before installing the new boiler. Power Flushing is the preferred option for existing installations because all high efficiency boilers tend to have smaller waterways than traditional boilers. A suitable system filter (e.g. Spirovent SV3-025-T) fitted in the boiler return is STRONGLY recommended in existing systems.

For optimum performance after installation of the new system, the boiler and its associated central heating system should also be flushed.

The flushing should be carried out in accordance with BS7593:1992 using cleaner such as Sentinel X300 or X400 or Fernox Superfloc.

4.1. INSTALLATION PREPARATION

Unpacking Of Boiler

Important: With regards to the Manual Handling Operations, 1992 Regulations, the following lift operation exceeds the recommended weight for one man lift.

Stand the boiler carton upright.

Cut and remove the securing straps and lift off the carton sleeve. Place aside any loose components until required.

Carefully lay the boiler on its back, remove the two front casing panel-securing screws and lift off the panel from the two retaining lugs.

Remove the two inner casing panel-securing screws at the bottom of the front panel, and then lift off the two retaining lugs.

4.1.1. Wall Template

A wall template is supplied with the boiler. This should be used to mark the boiler fixings and flue outlets and for checking the minimum clearances required.

4.1.2. Flue Hole Cutting

The standard horizontal flue is designed with an internal fall of 35mm/metre towards the boiler for disposal of condensate. If the standard flue length alone is being used then the flue hole of diameter 105mm can be cut in the position marked on the wall template.

For standard side flues the horizontal flue centre line on the wall template should be extended to the side wall, and the vertical centre of the flue hole marked at 176mm from the back wall.

For installations with external access, a 105mm diameter core drill can be used.

For installations with internal access only a 125mm diameter core drill should be used.

When using extension pipes with the horizontal rear flue, a core drill size of 125mm should be used to allow the extension pieces to slope at 35mm/metre (2.5°) towards the boiler.

For extended side flues, the flue hole centre should be determined by extending the dashed inclined line on the template to the side wall. This dashed line is drawn at 35mm/metre (2.5°) rise from the boiler. Where this line reaches the side wall, a horizontal line should be marked. The vertical centre line of the flue should then be marked at 176mm from the back wall, see diagram 5.3.

To allow for the flue passing through the wall at this angle a 125mm hole should be drilled irrespective of internal or external installation.

If necessary remove the wall template whilst drilling the flue hole.

4.2. Hanging Bracket Fixing

If previously removed, reposition the wall template over the flue hole and mark the position of the fixing holes for the hanging bracket.

Mark and drill the fixing holes and secure the hanging bracket.

4.3. BOILER FIXING

Important: With regards to the Manual Handling Operations, 1992 Regulations, the following lift operation exceeds the recommended weight for a one man lift.

Having previously secured the hanging bracket to the wall, lift the boiler into position in the following manner:-

Lean the top of the boiler slightly to the wall and position just above the hanging bracket. Allow the boiler to slowly move downwards until engaged in the hanging bracket.

4.4. CONNECTIONS

4.4.1. Gas Connection

Before connection check the supply of local gas.

The gas supply can be connected from below.

4.4.2. Water Connections

Provision is made for the water connections to be made from above the boiler. The position is shown on the wall template.

Flush out the domestic hot water and the central heating system before connecting to the boiler.

BOILER INSTALLATION

4.4.3. Condensate Drain Connection

Before fitting the condensate drainpipe, remove and fill the condensate trap with water and refit to the appliance.

The condensate will be slightly acidic and the condensate pipe should be run in a high temperature plastic drainpipe material (e.g. PP, UPVC etc). Copper tube **MUST NOT** be used and 'push fit' overflow pipe **MUST NOT** be used.

The actual outlet connection (shown opposite) is stepped to accept either 21 or 22mm O.D. pipework. The connections are designed to be a friction fit and particularly with 21mm pipe it is important that the pipe is long enough and pushed firmly home (use a quarter turn)

Internal pipe work should have a bore diameter no smaller than 20mm.

The external pipe work should be kept to a minimum, and have a bore diameter no smaller than 32mm.

The pipe should not have any upward pipe runs and must fall at least 2° (1:20) throughout its length towards the discharge point.

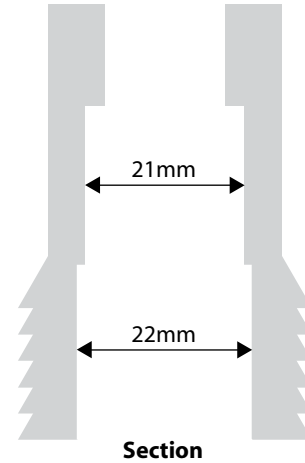

It is strongly recommended that the condensate pipe should be run internally to the house soil or vent stack or to a waste pipe.

Alternatively the condensate may be discharged into a rainwater system, external gully or a purpose-built soak away. Any local building control authority requirements must be complied with.

It is recommended that the pipe should not be installed externally but if it is it should be insulated and terminated below the grating level of the gully or at least 50mm above the soak away to minimise the effects of freezing.

5.1 GENERAL

Warning: The boiler must be permanently connected to a 230V~, 50Hz supply. This appliance **MUST BE EARTHED**.

All external wiring to the boiler must be in accordance with the latest I.E.E. Wiring Regulation, and any local regulations which may apply

There must be only one common isolator for the boiler and its control system, and it must provide complete electrical isolation via a double pole isolator fused at 3A maximum with a contact separation of at least 3mm in both poles.

The fused spur box should be readily accessible and preferably adjacent to the appliance and it should be identified as to its use.

Alternatively the connection can be made through an unswitched shuttered socket and 3A fused 3-pin plug both to the current issue of BS 1363 may be used, provided they are not used in a room containing bath or shower.

Do not interrupt the mains supply to the boiler with a time switch or a programmer.

In the event of an electrical fault after installation of the appliance, preliminary electrical checks must be carried out i.e. Earth Continuity, Short Circuit, Polarity, and Resistance to Earth.

Electrical components in this appliance have been tested to meet the requirements of the BEAB.

5.2 EXTERNAL CONTROLS

(Mains Voltage: 230V, 50Hz)

(a) The Gledhill boilers are fitted with wiring terminals inside the control panel as shown in diagram 5.2. The access to these terminals is gained by first removing the front cover by removing the two screws at the bottom (front) and then opening the hinged control panel by first unscrewing the retaining screw.

(b) Observe all terminal markings and colour codes as shown in diagrams 5.2 – 5.4 and table 5.1. Ensure that all flexible cords are routed through the strain relief cable glands and clamps located on the bottom of the boiler and in the control/wiring panel.

Table 5.1 Description of boiler wiring terminals

(c) Ensure that the separate external mains supply, control and pump cables are fed to the boiler. Connect both the mains supply and switched live supply from the external controls (e.g. room thermostat, BoilerMate) into the marked terminals as shown in diagrams 5.2, 5.3 and 5.4. For the conventional heating systems also connect the pump supply into the marked pump terminals as shown in diagrams 5.2 and 5.3

(d) The controller in this boiler is phase sensitive. Therefore if mains supply 'Live' and 'Neutral' are reversed, the controller will not work and the error message will be displayed.

(e) Electrical Connection Testing

Carry out the preliminary electrical checks below after wiring and before switching on the supply: -

- The insulation resistance to earth of mains cables.
- Test the earth continuity and short circuit of cables.
- Test the polarity of the mains.

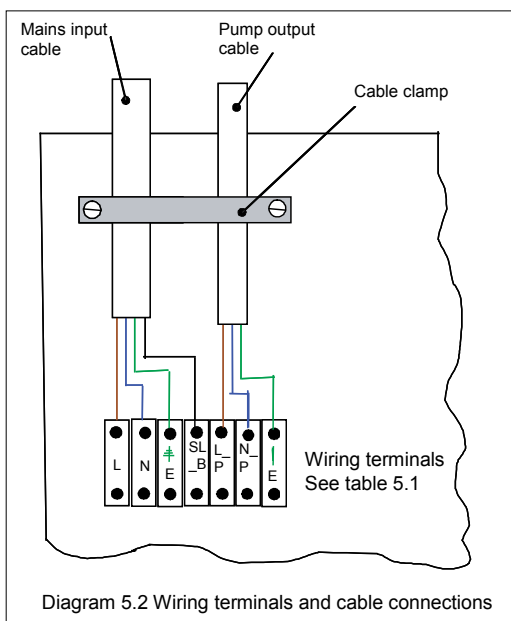

Terminal	Description
L	Mains (L) supply – 230V ~ 6A rated cable (0.75mm ²)
N	Mains (N) supply – 230V ~ 6A rated cable (0.75mm ²)
E	Mains (GND, E) supply – 0V ~ 6A rated cable (0.75mm ²)
SL-B	Switched Live (L) supply – 230V~ 6A rated cable (0.75mm ²)
L-P	Supply to pump (L) – 230V~ 3A rated cable (0.75mm ²)
N-P	Supply to pump (N) – 230V~ 3A rated cable (0.75mm ²)
E	Supply to pump (GND, E) – 0V ~ 6A rated cable (0.75mm ²)

ELECTRICAL WIRING

5.2.1 Wiring – Conventional Systems

(a) The schematic wiring diagram of a conventional heating system with vented or unvented domestic hot water storage is shown in diagram 5.3. Although the diagram shows 2 zone valves, the boiler is equally suitable for systems designed with a 3-port valve.

(b) When designing and planning the system wiring, take into account recommendations of control manufacturers and requirements of controls selected.

(c) The boiler incorporates pump overrun control logic. Therefore only feed the system pump from the boiler wiring terminals marked 'L-P', 'N-P', and 'E' (see diagrams 5.2 and 5.3) and not from a separate electrical supply.

(d) The boiler has integrated frost protection control logic to prevent the boiler from freezing. This will be automatically activated if the temperature inside the boiler drops below 5°C provided the electricity and the gas supplies to the boiler are not switched off. (Note: Automatic frost protection is only activated if no jumper is fitted across terminals 1&9 -J3 on the control PCB.) If frost protection is required for other parts of the heating circuit, then a 230Vac frost thermostat should be wired as shown in diagram 5.3.

(e) After completing the wiring carryout electrical testing (section 5.2 (e)) and refit the appliance control panel and front cover. Please ensure that the

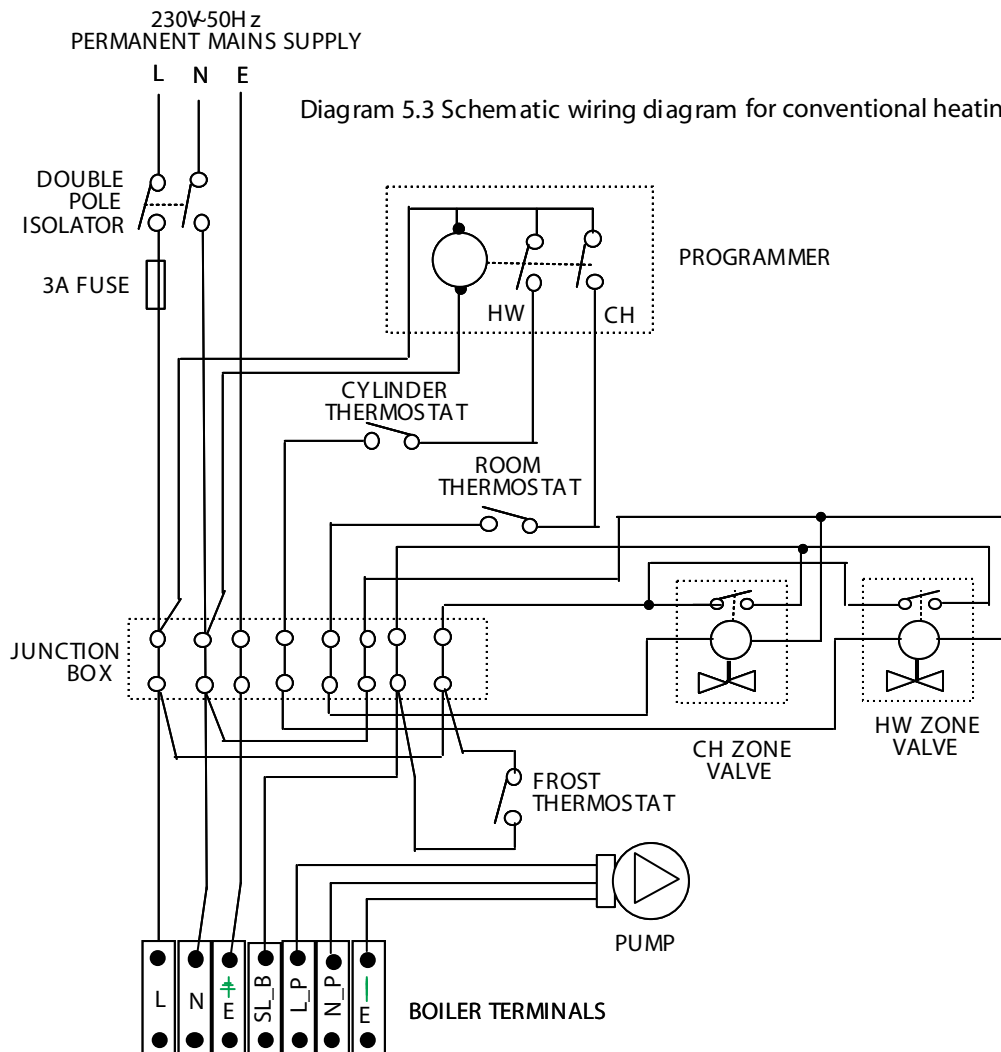
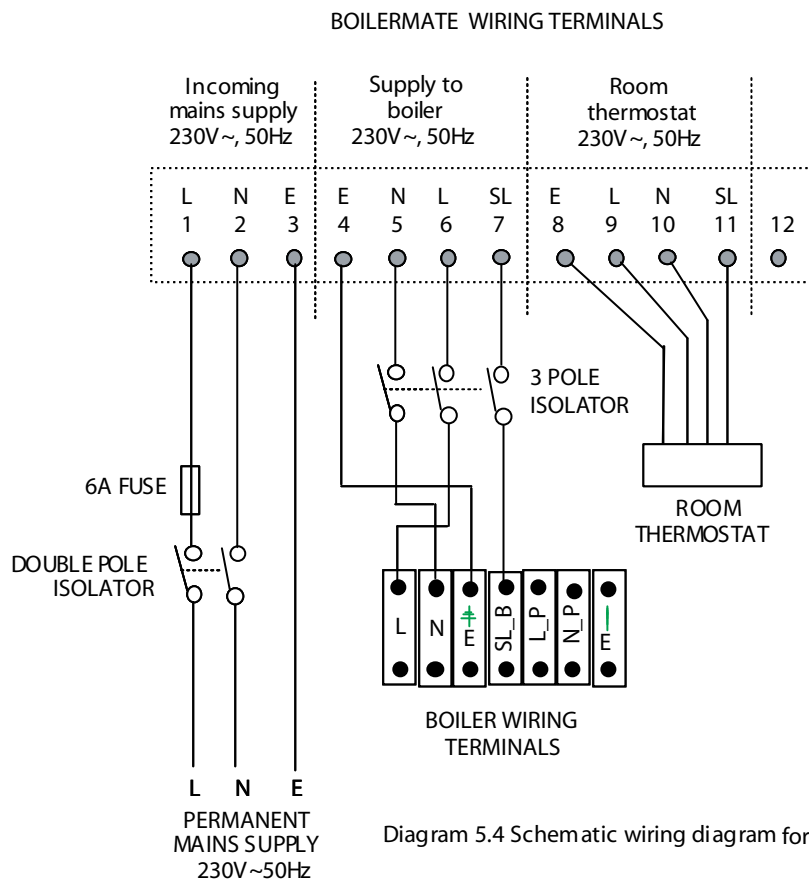

Diagram 5.3 Schematic wiring diagram for conventional heating system

5.2.2. Wiring – BoilerMate OV/BoilerMate SP

- (a) The schematic wiring diagram of Gledhill BoilerMate based heating and hot water system is shown in diagram 5.4.
- (b) When a boiler is coupled to a BoilerMate, then the mains electricity supply from the isolator must be to the BoilerMate and the boiler should be supplied from the BoilerMate via a secondary 3 pole isolator as shown in diagram 5.4.
- (c) When designing and planning the system wiring, take into account recommendations of control manufacturers and requirements of controls e.g. programmer and room thermostat selected.
- (d) The boiler pump overrun is provided by the BoilerMate controller.
- (e) The frost protection control logic of the boiler must be disabled by inserting a jumper on pins 1&9 of connector J3 on the main PCB (see diagram 8.3). If frost protection is required for any part of the heating circuit, then a 230Vac frost thermostat should be wired as shown in the BoilerMate manual.
- (f) After completing the wiring carryout electrical testing (section 5.2 (e)) and refit the appliance control panel and front cover. Please ensure that the 'Benchmark' logbook is completed and left with the user.



COMMISSIONING

6.1. General

Commissioning should be carried out by a competent person in accordance with the current issue of BS6798. Make sure that the system has been thoroughly flushed out with cold water. Refill the system with water, making sure that all the air is properly vented from the system. Before operating the boiler check that all external controls are calling for heat.

With a sealed system fill the system until the pressure gauge registers the recommended pressure. Clear all air from the system and check for leaks. Check the operation of the safety valve, preferably by allowing the water pressure to rise until the valve lifts. This should be within ± 0.14 bar of the preset pressure. Where this is not possible a manual check should be carried out. The system pressure should then be reduced to the initial design pressure.

NOTE: A manual air vent is provided on top of the heat exchanger to allow air to be removed from the boiler during filling/commissioning. The boiler front panel will need to be removed to gain access to the vent. The vent should be closed during normal operation.

6.2. Initial Lighting

Isolate the boiler from the mains electrical supply. Test for gas soundness and purge any air from the gas supply. The boiler lighting procedure operates automatically once the switch on the appliance is in the ON position (indicated by flame symbol) and any external controls are calling. The dot D1 will begin to flash to indicate that the controller is active. When the burner is lit, the dot D1 will be on constant. If the boiler fails to light it will attempt to ignite 5 times before showing ignition lockout at which point D2 will begin to flash. Initially this may be due to air in the gas supply line and can be reset with button S1. After the boiler has fired allow it to warm up the system and purge any remaining air from the system, the appliance will continue to fire until the user controls are satisfied.

6.3. Testing – Gas

The gas rate can be checked using the gas meter and a stopwatch after the burner has been running for 10 minutes. Before a gas rate check is made make sure all other gas burning appliances are turned off and the temperature of the heating/hot water system is such that the controls will remain calling for heat.

As a guide the approximate gas rates are:	
GB30	3.3 m ³ /h at maximum fan speed
GB25	2.7 m ³ /h at maximum fan speed
GB20	2.2 m ³ /h at maximum fan speed
GB15	1.6 m ³ /h at maximum fan speed
GB10	1.1 m ³ /h at maximum fan speed

IMPORTANT

The gas valve and the Venturi are factory set and sealed. These should not need any adjustment and MUST NOT be tampered with. However, check that a supply pressure of 20mbar is available at the boiler when it is firing at full rate.

6.4. Testing – Heating System

Check that all controls are calling for heat, fully open all radiator valves and allow the heating system to heat up. Balance the radiators as requires giving the required differential across the heating system and set the bypass. Turn off all user radiator valves that can be turned off and check that the maximum differential achievable across the flow and return is less than 20°C.

Allow the system to achieve full temperature and then switch off and isolate the appliance. Drain the system whilst still hot from the lowest part of the system ensuring all parts of the system are emptied. Fill and vent the system as described previously.

6.5. Testing – User Controls

Check all external time and temperature controls are fully operational and give the expected response to user operation. Check the operations of the on/off and reset switch on the boiler.

When the burner is lit, the dot D1 will be on constant.

A fault is indicated by flashing dot 'D2'. To reset press 'Set/Reset' button S1.

6.6. Frost Protection

The boiler has frost protection built into its operation programme, for conventional heating systems, but requires the gas and electricity to be switched on. This programme operates the burner and system pump if the temperature inside the boiler falls below 5°C provided no 'jumper' is fitted across terminals 1+9_J3 on the control PCB. This device is designed to protect the boiler only and any other exposed area of the system should be protected separately by a frost thermostat.

6.7. Instruct the User

A demonstration of the lighting procedure and advise of safe and efficient operation should be given to the user. The use and operation of the heating system controls should also be demonstrated to the user along with the use and maintenance of any other equipment e.g. scale reducers that may be fitted to the system.

Advise that to continue with safe and efficient operation of the boiler it is recommended that the boiler is checked and serviced at a regular interval of a minimum of once a year.

Advise that like all condensing boilers this appliance will produce a plume from the flue terminal in cold weather and this is normal for a high efficiency boiler.

Advise the user of the precautions necessary to prevent damage by frost and freezing conditions if the system is out of use. Along with a need to keep the electrical and gas supplies switched on to enable the automatic frost protection to work.

Draw attention to the law that any servicing should be carried out only by a competent person and if applicable to the current issue of the Gas Safety (Installation & Use) Regulations, Section 35, which imposes a duty of care on all persons who let out any property containing a gas appliance.

7.1. General

IMPORTANT

DO NOT TAMPER WITH THE APPLIANCE OR BREAK ANY SEALS ON THE PRE-SET CONTROLS (BURNER OFFSET PRESSURE AND THROTTLE SETTINGS) OF THE APPLIANCE. IF IT IS NECESSARY TO REPLACE ANY OF THE SEALED PARTS, THEN THESE SHOULD BE REPLACED BY FACTORY SET AND SEALED PARTS SUPPLIED BY GLEDHILL LTD.

Measurement of the products of combustion can be achieved by connection of a probe to the combustion analyser test point on the flue elbow connecting the boiler to the flue system.

Before commencing with a service or replacement of parts the boiler should be isolated from the electrical supply and the gas supply should be turned off at the gas isolation valve.

All routine service requirements can be achieved by the removal of the front cover, inner casing panel and lower casing panel as described in section General 9.1. Unless stated otherwise parts are replaced in the reverse order of removal. Servicing should always include the removal of any debris from the condensate trap. After completing any servicing of gas carrying components ALWAYS test for gas soundness and carry out a functional test of the controls.

It is recommended that all subsequent service calls are recorded on the Service Interval Record which can be found on page 36.

Details from the Benchmark Checklist and Service Interval Record will be required when requesting warranty work. Failure to provide these details or the lack of a current service will delay a warranty visit and may incur a charge for the visit.

7.2. Spark & Flame sensing electrodes

For access refer to section General 9.1

Remove the spark plug style connector from the electrode and earth lead in the case of the spark electrode. Remove the two retaining screws with a Torx T20 driver, carefully withdraw the electrode from the combustion chamber. Inspect the tips for damage, clean away any debris and check the spark gap is 3.5-4.5mm. Check the electrode gasket for signs of damage and replace if necessary.

7.3. Burner

For access refer to section General 9.1 & 9.1.1

Clean the burner with a soft brush taking great care not to damage the front insulation. DO NOT use wire or sharp instruments to clean the holes in the burner. Inspect the burner for any signs of damage.

Removal of the burner is not necessary during a normal service.

NOTE: IF THE BURNER HAS TO BE REMOVED IT WILL REQUIRE A NEW GASKET WHEN REFITTED.

When replacing the assembly ensure the sealing grommet is correctly fitted.

7.4. Combustion Chamber and Heat Exchanger

For access refer to section General 9.1 & 9.1.1

Remove loose debris from the combustion chamber using a soft brush and vacuum cleaner. Carefully flush any remaining debris by spraying water through to the condensate trap (ensuring the water is kept away from electrical components).

7.5. Condensate Drain

For access refer to section General 9.1

Remove the yellow cap from the bottom of the trap and remove any solids found. Remove the flexible condensate pipe connection from the bottom of the heat exchanger and the drain connection downstream of the condensate trap. Remove the condensate trap and flush water through the trap to remove any remaining solids. Reassemble the trap and connection ensuring a watertight seal is achieved.

7.6. Inner Casing Panel Seal Check

For access refer to section General 9.1

Check the condition of the seal, replace as required. To replace remove the old seal, thoroughly clean the casing surfaces. Fit the new seal, it is supplied to the correct length.

7.7. Combustion Check

Once the appliance has been reassembled (apart from the front and inner panel) connect a CO₂ combustion analyser to the test point on the flue elbow.

FAULT FINDING

External faults

Before carrying out boiler fault finding or any component replacement, check for any installation faults that may be causing the appliance to malfunction. For example, is the gas simply turned off, is the external wiring incorrect, is the appliance filled and vented.

Boiler will not fire

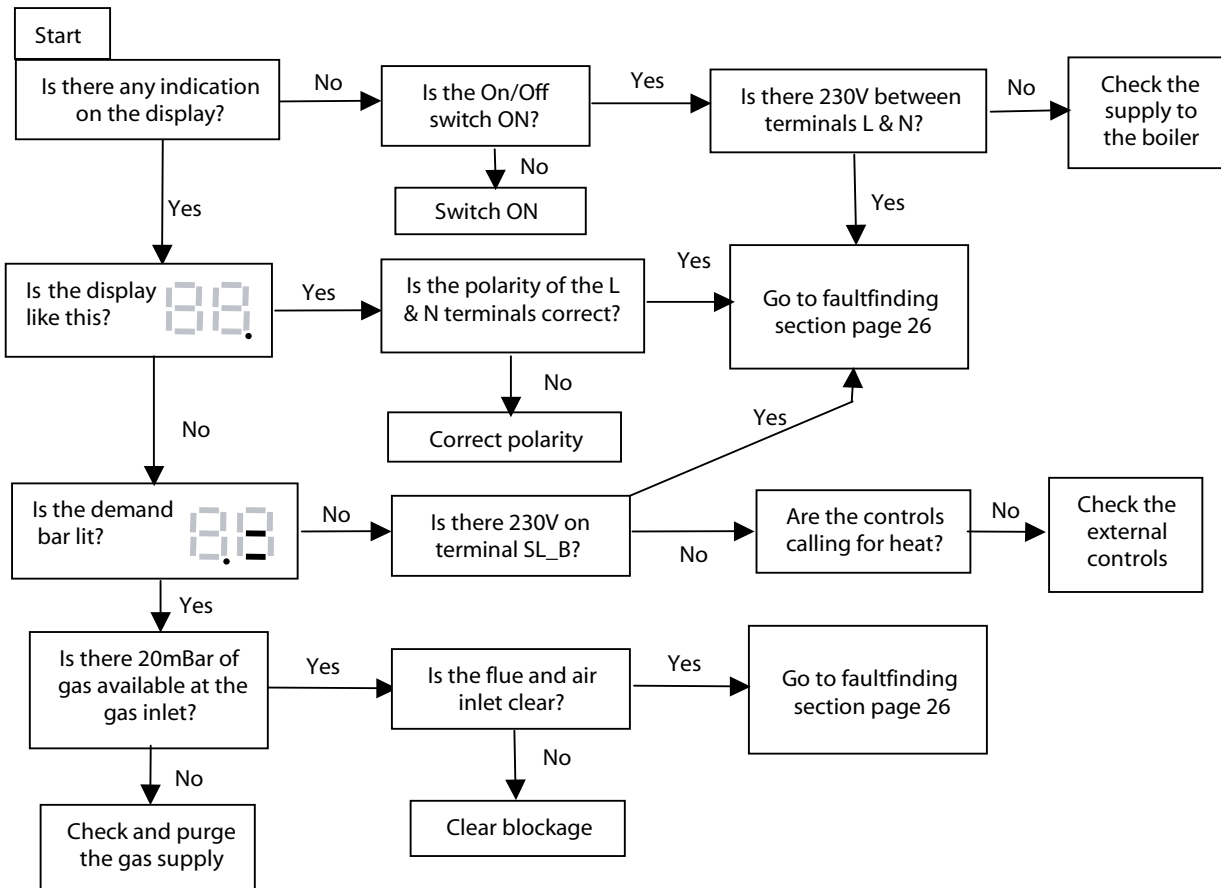

Boiler fires then locks out

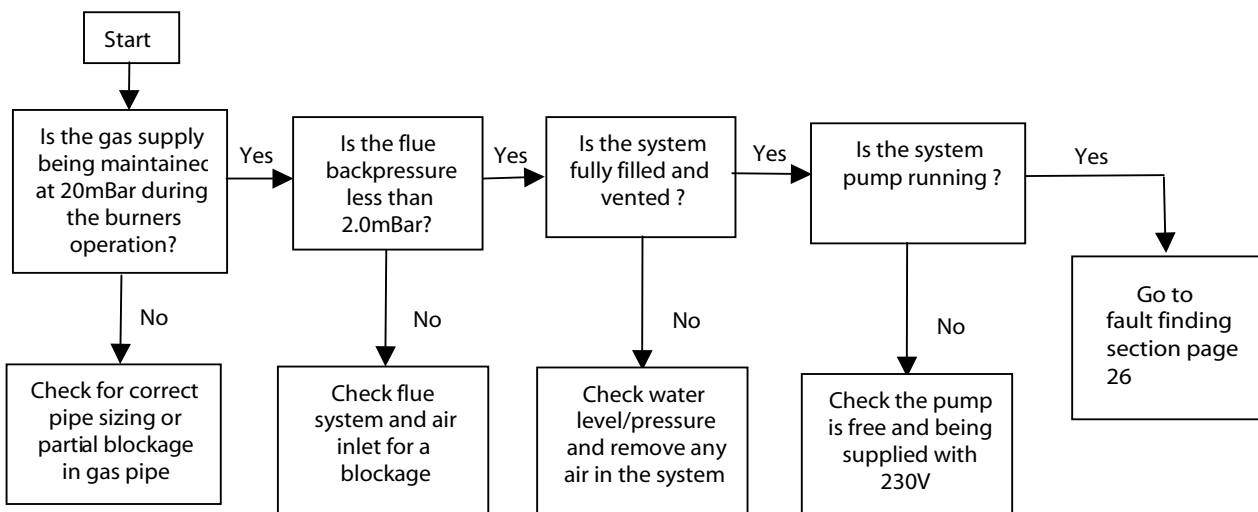

8.1. CONTROLLER DISPLAY

The controller display unit is equipped with a two digit, 7 segment display and three push buttons as shown schematically shown in diagram 8.1. The display shows the system status and can be used to display diagnostic information.

The push buttons can be used to enter the parameter menu and to change the parameters. The push button S1 is also used to clear locking errors and reset the controller.

8.1.1. Normal Level-1 (Default) Operation

The information display in normal user (Level-1) mode is described below in table 8.1. If no input is detected when the display is in level 2 or level 3 mode for a period of around 20 seconds, it will automatically revert back to default level 1 mode.

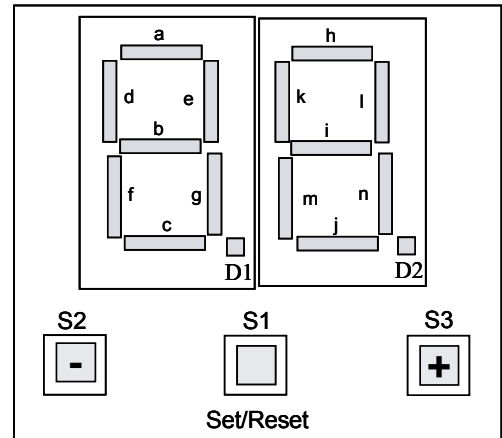

Diagram 8.1 Controller display

Table 8.1: Level-1 Display description	
Display segment	Description
D1	On/Off : Indicates that the controller is active and in standby mode
	On : Indicates ionisation i.e. burner is on
D2	On/Off : Lockout error – Requires reset
	On : Blocking error detected
b	Controller is initialising
h	Overheat safety trip
a, d, b & f	'F' – Frost program active
i	Heat demand on
j	Pump on

8.1.2. Level-2 Display Operations

The level-2 is used to display the temperatures, set points and errors. The information flow diagram for level-2 is shown below in diagram 8.2. Push buttons S2 and S3 are used to select the parameters vertically and horizontally respectively.

The level-2 is accessed by pressing and holding push button S1 for minimum of 10s. The controller display will go back to level 1 if either there has been no input (i.e. buttons pressed) for 30s or if push button S1 is pressed and held for 10s.

(a) Temperature display

The temperature of the sensor selected is displayed by alternatively flashing the sensor number and the temperature measured by it or 'Er' if it is in error. The sensor definition is shown in table 8.2.

(b) Set point display

The selected set point is displayed by alternatively flashing the set point number (P1...P6) and the corresponding set point. The definition of set points is listed in table 8.3.

Table 8.2: Sensor Description		
Sensor	Description	Error Codes
S1	Boiler Flow (NTC)	E1: Sensor or cables shorted E2: Sensor or cables open circuit E3: Temperature reading >99°C
S2	Boiler Return (NTC)	E1: Sensor or cables shorted E2: Sensor or cables open circuit E3: Temperature reading >99°C
S3	Flue Gases (NTC)	E1: Sensor or cables shorted E2: Sensor or cables open circuit E3: Temperature reading >99°C
S4	TID	E1: ID resistor short circuit E2: ID resistor open circuit E3: ID resistor >99°C

FAULT FINDING

(c) Lockout fault code display

In this mode the lockout fault codes are displayed. The button S2 is used to select this mode and the button S3 is used to cycle between the stored faults. Fault code reading is displayed by alternatively flashing the fault number and the internal error number.

There are 16 fault codes stored in order of occurrence. The fault code 'C0' is the current or last fault code and the fault code 'CF' is that happened the longest time ago.

When no fault is stored at the displayed fault number, an 'FF' is displayed. It is also possible that 'EE' is displayed for an internal error number. This means that the controller is busy reading the memory. The lockout error codes are listed in table 8.5.

The locking errors can be cleared by pressing the reset button S1

(d) Block out fault code display

In this mode the block out fault codes can be displayed. The button S2 is used to select this mode and the button S3 is used to cycle between the stored faults. Fault code reading is displayed by alternatively flashing the fault number and the internal error number.

There are 16 fault codes stored in order of occurrence. The fault code 'c0' is the current or last fault code and the fault code 'cF' is that which happened the longest time ago.

When no fault is stored at the displayed fault number, an 'FF' is displayed. It is also possible that 'EE' is displayed for an internal error number. This means that the controller is busy reading the memory. The block out error codes are listed in table 8.6.

The error will be reset when fault is cleared. To reset some internal errors switch power off, wait 10 seconds and switch power on again.

Set point number	Description
P1	blr_flow_setpoint, (S1)
P2	blr_flow_hysteres, (S1)
P3	blr_return_setpoint, (S2)
P4	blr_return_hysteres, (S2)
P5	max_flue_setpoint, (S3)
P6	blr_flow_overheat

Model	Boiler ID	ID resistor
GB10	A0	1K, (T_ID=100)
GB15	A1	1K5, (T_ID=66)
GB20	A2	2K2, (T_ID=73)
GB25	A3	3K3, (T_ID=61)
GB30	A4	4K7, (T_ID=51)

8.1.3. Level - 3 Display Operations

The level 3 is used for setting the boiler flow temperature and selecting the boiler model. This level is intended for use by the installer/service engineer. The level 3 setting menu is accessed by simultaneously pressing and holding the push buttons S2 and S3 for at least 10 seconds.

The setting level is indicated by flashing '0' on the LH digit of the display and solid '0' on the RH digit of the display.

(a) Boiler model selection

The parameter to be set is selected by using buttons S2 or S3. The display is cycled using these buttons until 'A' flashes on the LH digit and the current boiler ID (0...4) is shown on RH digit.

The boiler models and their ID codes are listed in table 8.4. To change the boiler ID press and hold button S1 until RH digit starts to flash. Select the boiler ID using buttons S2 or S3. Press and hold button S1 to confirm the selected boiler ID.

If the selected boiler ID matches the ID resistor fitted, the RH digit will stop flashing. The controller will now be operational and will use the boiler model specific data (e.g. fan speeds) for future control actions

If the selected boiler ID does not match the ID resistor fitted, the RH digit will display flashing 'E'. The T_ID values corresponding to the ID resistors are shown on PC serial screen.

If the controller does not sense any further inputs from buttons S1, S2 or S3 for a period of 20s, it will revert back to normal display.

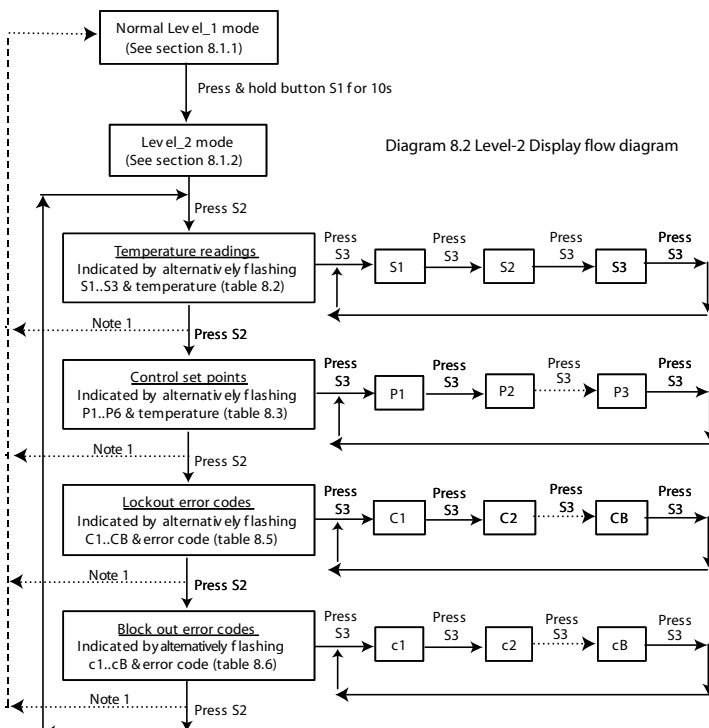

Note 1: When the controller display is in level 2 and there has been no inputs (i.e. no buttons pressed) for a period of 20s or if button S1 is pressed and held for 10s then the display will go back to level 1.

Table 8.5 Lockout error codes		
'C' code	Error	Description
no	Description	
0	E2PROM_READ_ERROR	Unable to read E2Prom contents
1	IGNIT_ERROR	No flame detected after 3 ignition attempts
2	SPARE_LOCK_ERROR	
3	SPARE_LOCK_ERROR_0	
4	SPARE_LOCK_ERROR_1	
5	GV_RELAY_ERROR	Gas Valve Relay not opening or closing correctly
6	SAFETY_RELAY_ERROR	Safety Relay not opening or closing correctly
7	SPARE_LOCK_ERROR_1A	
8	FAN_ERROR	Fan does not run at correct speed
9	RAM_ERROR	Ram check in processor is not correct
10	WRONG_EEPROM_SIGNATURE	E2Prom content does not correspond with main software
11	CH_MAX_ERROR	
12	E2PROM_ERROR	E2Prom contents corrupt
13	STATE_ERROR	Internal software error
14	ROM_ERROR	Internal software error
15	OVERHEAT_ERROR	S1 sensor above maximum overheat temperature
16	15MS_XRL_ERROR	Internal software error
17	SENS_DIFF_ERROR	
18	T_MAX_LOCK_ERROR	
19	STACK_ERROR	Internal software error
20	FLAME_OUT_TOO_LATE_ERROR	After closing the gas valve the flame was detected for a period longer than 10 secs
21	FLAME_ERROR_1	Flame detected prior to opening the gas valve
22	20MS_XRL_ERROR	Internal software error
23	41MS_ERROR	Internal software error
24	TOO_MANY_FLAME_FAILURES	Too many flame failures within one heat demand cycle
25	FLAME_FLAG_CPL_ERROR	
26	WD_DATABYTE_CPL_ERROR	
27	FLAG_BYTE_INTEGRITY_ERROR	
28	AD_HI_CPL_ERROR	
29	AD_LO_CPL_ERROR	
30	REGISTER_ERROR	

(b) Boiler flow temperature setting

The parameter to be set is selected by using buttons S2 or S3. The display is cycled using these buttons until 'P' (on the LH digit) and the current maximum boiler flow temperature setting (e.g. 77) starts to flash alternatively

To change the maximum boiler flow temperature setting, press and hold button S1 until the digits stop flashing and only the current set temperature is displayed.

Change the boiler flow set point using buttons S2 or S3. Press and hold button S1 to confirm the setting until 'P' (on the LH digit) and the current maximum boiler flow temperature setting (e.g. 77) starts to flash alternatively.

If the controller does not sense any further inputs from buttons S1, S2 or S3 for a period of 20s, it will revert back to normal display.

8.2. ERROR/FAULT CODES

The errors are divided into two groups; blocking errors which will disappear when error is cleared and the non volatile locking errors which can only be reset by pressing the reset button.

The locking errors are shown in table 8.5 and these will be indicated with 'C' prior to the error number. The blocking errors are shown in table 8.6 and these will be indicated with 'c' prior to the error number.

FAULT FINDING

Table 8.6 Blocking error codes		
'c' code	Error	Description
31	REFHI_TOO_LO_ERROR	Temperature measurement incorrect
32	REFHI_TOO_HI_ERROR	Temperature measurement incorrect
33	REFLO_TOO_LO_ERROR	Temperature measurement incorrect
34	REFLO_TOO_HI_ERROR	Temperature measurement incorrect
35	SPARE_BLOCK_ERROR	
36	FLAME_ERROR_2	Flame detected with a closed gas valve
37	SPARE_BLOCK_ERROR_0	
38	FS_NOT_OPEN_ERROR	
39	FS_NOT_CLOSED_ERROR	
40	SPARE_BLOCK_ERROR_3	
41	SPARE_BLOCK_ERROR_4	
42	CH_MAX_BLOCK_ERROR	
43	SPARE_BLOCK_ERROR_5	
44	PHASE_ERROR	Mains supply live and neutral reversed
45	50HZ_ERROR	Mains frequency is not 50Hz
46	FAULTY_EARTH_ERROR	Earth Connection/Ground incorrect
47	WD_COMMUNICATION_ERROR	Communication issue between main and watchdog processors
48	APPLIANCE_SELECTION_ERROR	Incorrect appliance type selected for appliance ID
49	MULTIPLE_SENSOR_ERROR	Errors with more than 1 sensor
50	SENSOR_00_OPEN	
51	SENSOR_01_OPEN	
52	SENSOR_02_OPEN	
53	SENSOR_03_OPEN	
54	SENSOR_04_OPEN	
55	SENSOR_05_OPEN	
56	SENSOR_06_OPEN	
57	SENSOR_07_OPEN	
58	SENSOR_00_SHORTED	
59	SENSOR_01_SHORTED	
60	SENSOR_02_SHORTED	
61	SENSOR_03_SHORTED	
62	SENSOR_04_SHORTED	
63	SENSOR_05_SHORTED	
64	SENSOR_06_SHORTED	
65	SENSOR_07_SHORTED	
66	RESET_BUTTON_ERROR	Reset button pressed too many times within a short period
255	NO_ERROR	

8.3. SERIAL SOFTWARE

In order to check the control and to set the parameters in its E2PROM, serial software is provided. To use this software a windows PC with serial port (COMP port) or a USB port is needed.

8.4. INTERNAL WIRING DIAGRAM

The appliance wiring diagram is shown in diagram 8.4. Ensure that wiring details are followed when a PCB, wiring harness or components are changed.

Diagram 8.3 Level-3 Display flow diagram

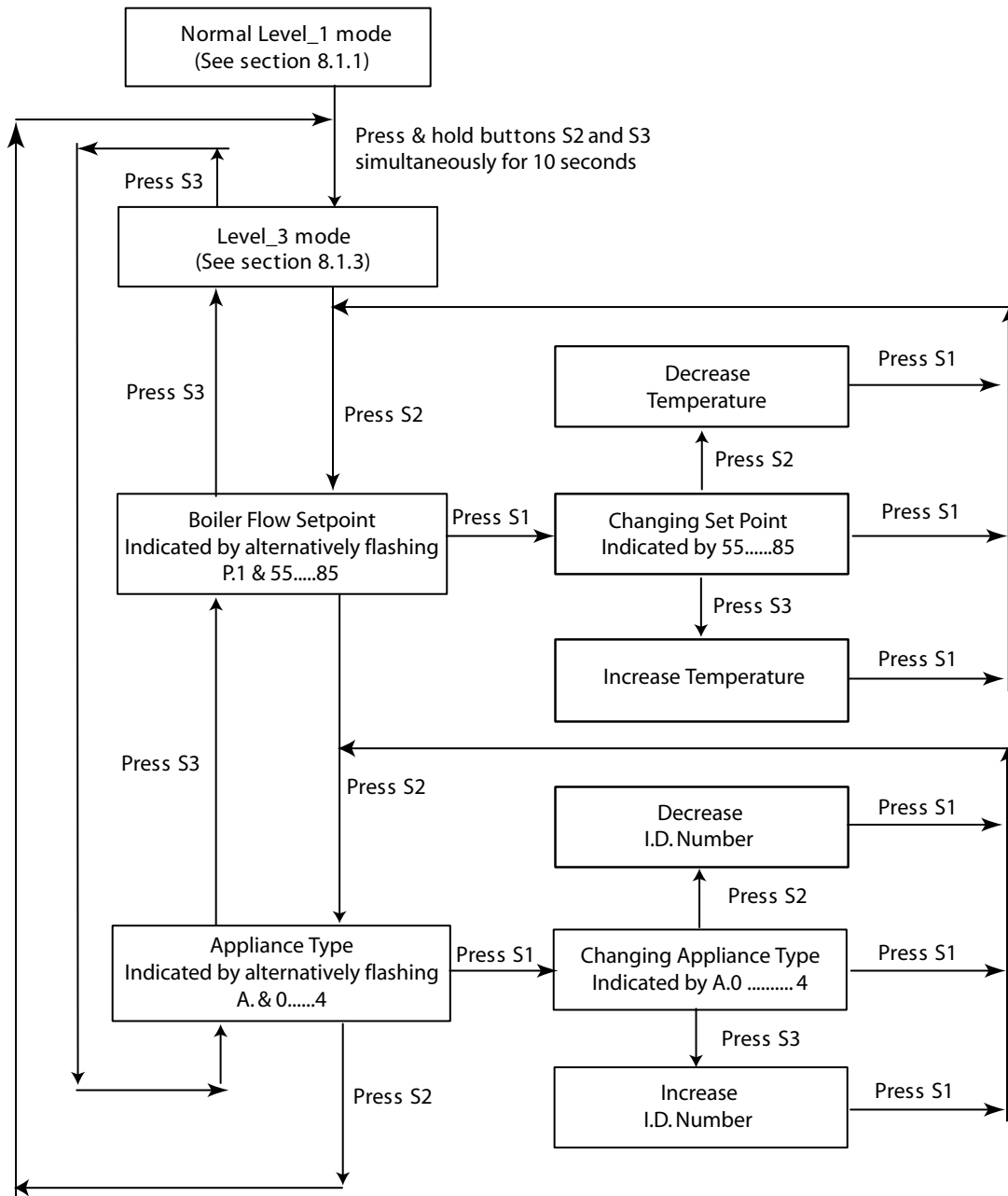

FAULT FINDING

Diagram 8.4 GWS Wall mounted boiler internal wiring diagram (Version: 190105)

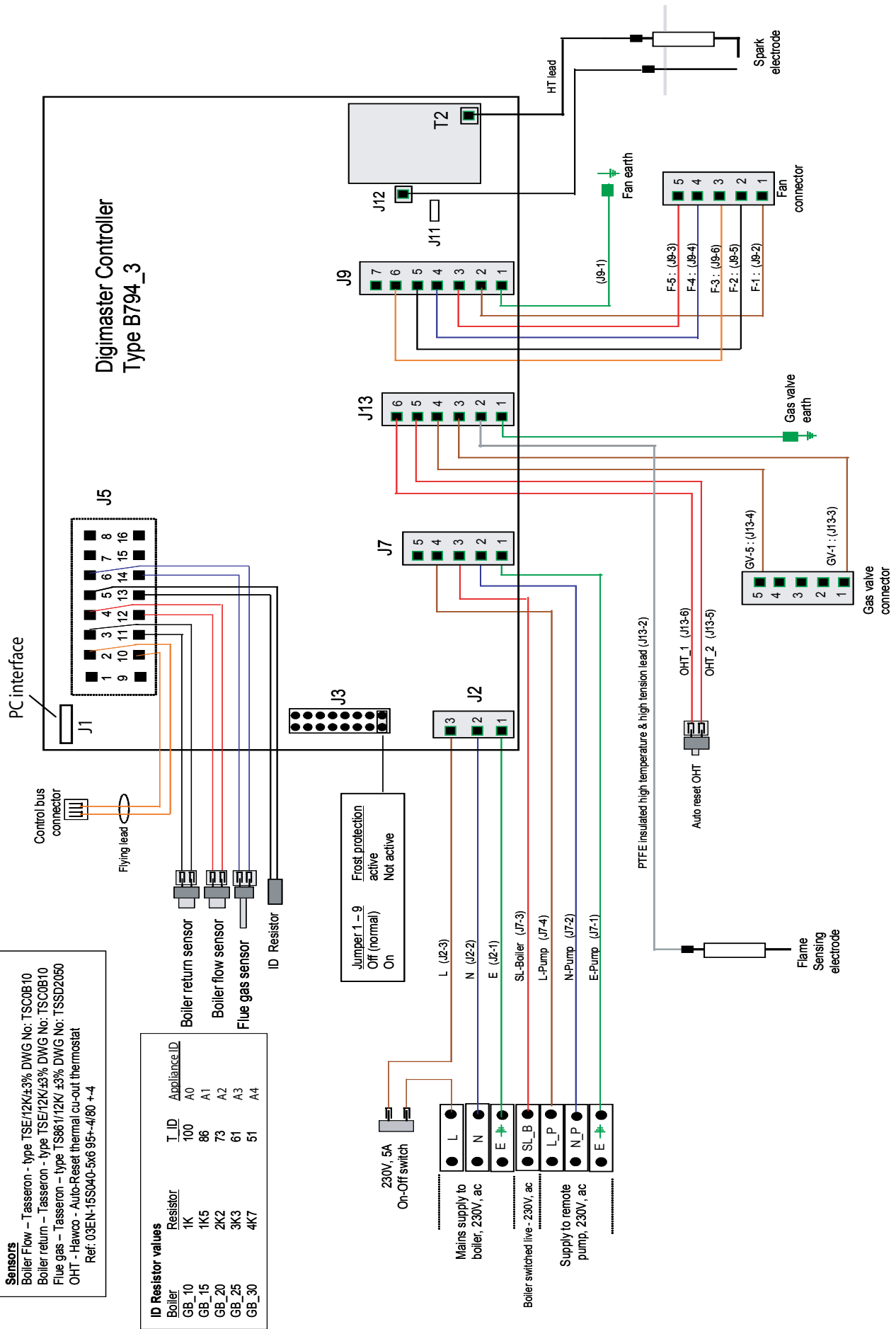

9.1. General

A competent person must carry out replacement of parts. Before replacing any parts the boiler must be isolated from the mains electric supply and the gas must be turned off at the service valve on the boiler. Unless stated otherwise parts are replaced in the reverse order of removal. After replacing any parts always test for gas soundness and if necessary carry out a functional test of the controls.

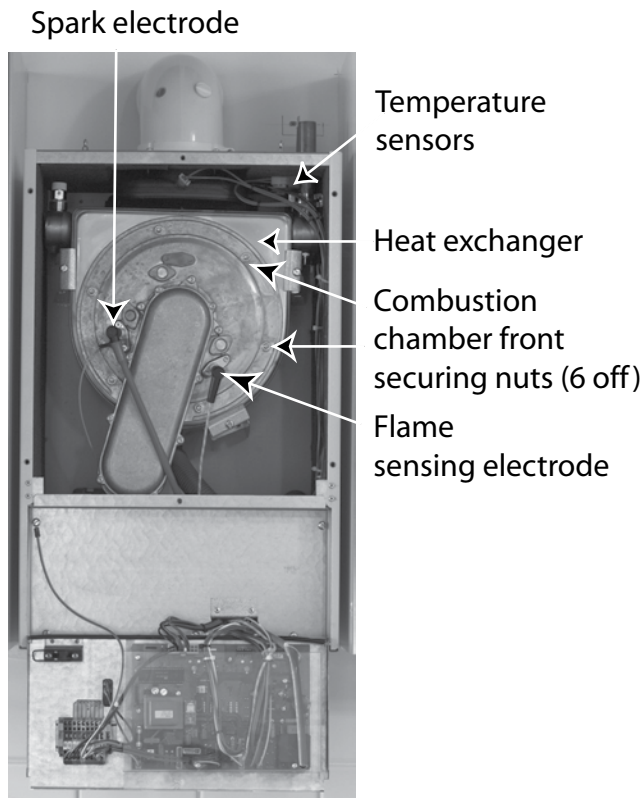

For replacement of parts the front cover, inner casing panel and lower casing panel will need to be removed. The front cover is held with locating pins at the top and retaining screws at the bottom. The retaining screws should be removed from the bottom and the panel lifted clear of the locating pins. To remove the inner casing undo the four retaining screws holding the inner casing panel and the lower casing panel is held by a further three screws.

NOTE: The gas valve and Venturi are a single assembly which is factory set and sealed. This must not be tampered with and must be changed as a single assembly.

9.1.1

The burner, fan, gas valve and venturi form part of a sub-assembly that must be removed before one of them can be replaced. To remove the sub-assembly remove the electrical plugs from the fan and gas valve and remove the earth connections from the gas valve and fan. Remove the gas connection, then the six nuts securing the combustion chamber front cover with a 10mm AF spanner. Carefully withdraw the sub-assembly from the combustion chamber.

Note: The burner will require a new gasket when refitted.

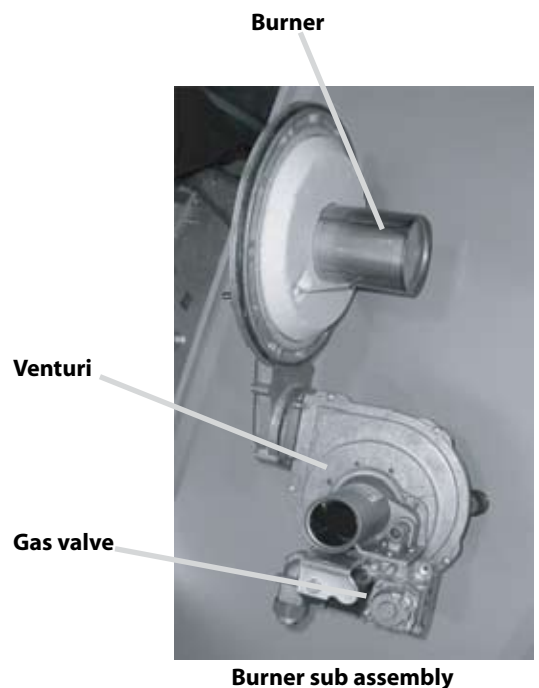

REPLACEMENT OF PARTS

9.2. Spark & Flame sensing Electrodes

For access refer to section General 9.1

Remove the spark plug style connector from the electrode and earth lead in the case of the spark electrode. Remove the two retaining screws with a Torx T20 driver, carefully withdraw the electrode from the combustion chamber.

9.3. Ignition & Flame sensing Leads

For access refer to section General 9.1

Pull off the spark plug style connector off the electrode and the spade connector from the control pcb.

9.4. Fan

For access refer to section General 9.1 & 9.1.1

Remove the two slotted screws holding the gas valve and venturi to the fan then remove the four nuts securing the fan to the gas manifold with a 8mm AF spanner. Check and replace any seals and gaskets necessary.

9.5. Burner

For access refer to section General 9.1 & 9.1.1. Remove the three screws securing the gas manifold to the combustion chamber front with a Torx T25 driver. This will release the burner.

The burner size depend upon the model of the boiler (see table below) therefore when replacing the burner ensure that the correct replacement burner is used.

Gledhill Boiler model	Burner length (mm)	Gledhill Part number	Gas Council number
GB10	92.6	GT991	
GB15	104.6	GT992	
GB20	135.8	GT993	
GB25	167.0	GT994	
GB30	167.0	GT994	

9.6. Temperature Sensors

For access refer to section General 9.1

The flow and return sensors have built in retaining clips and are removed as follows. Remove the electrical connections from the sensor, the sensor is removed from the pipe by putting equal pressure on the sensor head and the clip ends that are located 180° from each other. The flue gas sensor is removed with a 15mm AF spanner after having its electrical connections removed.

9.7. Heat exchanger

For access refer to section General 9.1 & 9.1.1

After removing the burner sub-assembly drain the boiler and remove the condense pipe from the bottom of the heat exchanger. Remove the clips securing the flow and return connections onto the heat exchanger. Loosen the three heat exchanger securing screws and clamps (two at the top and one at the bottom) to remove the heat exchanger. CAUTION there will still be some water in the heat exchanger.

9.8. Insulation

For access refer to section General 9.1 & 9.1.1

Remove the sub assembly as described above and replace the front insulation on the combustion chamber front cover.

9.9. Overheat thermostat

For access refer to section General 9.1

9.10. Fuses

For access refer to section General 9.1

The fuse is located on the left hand side of the main control pcb.

9.11. On-Off Switch

For access refer to section General 9.1

Remove the electrical connectors from the rear of the switch, squeeze the holding tabs on each end of the switch. The switch will now push through the front panel.

9.12. Gas Valve

The gas throttle on air/gas venturi (i.e. CO2 level) and offset pressure settings of the gas valve fitted to this boiler are factory set and sealed. These settings should not be adjusted. The gas valve and Venturi assembly must only be replaced by a factory set and sealed replacement supplied by Gledhill Ltd.

For access refer to section General 9.1 & 9.1.1

Remove the three screws securing the gas valve to the venturi using a Torx T25 driver. Check and replace any seals and gaskets as necessary. After replacing the gas valve the combustion CO2 will need to be checked.

9.13. Controller PCB

For access refer to section General 9.1

Remove the four slot screws securing the Perspex cover and remove the wiring plugs from the pcb. With a 6mm AF spanner remove the four nylon stand offs securing the control pcb.

REPLACEMENT OF PARTS

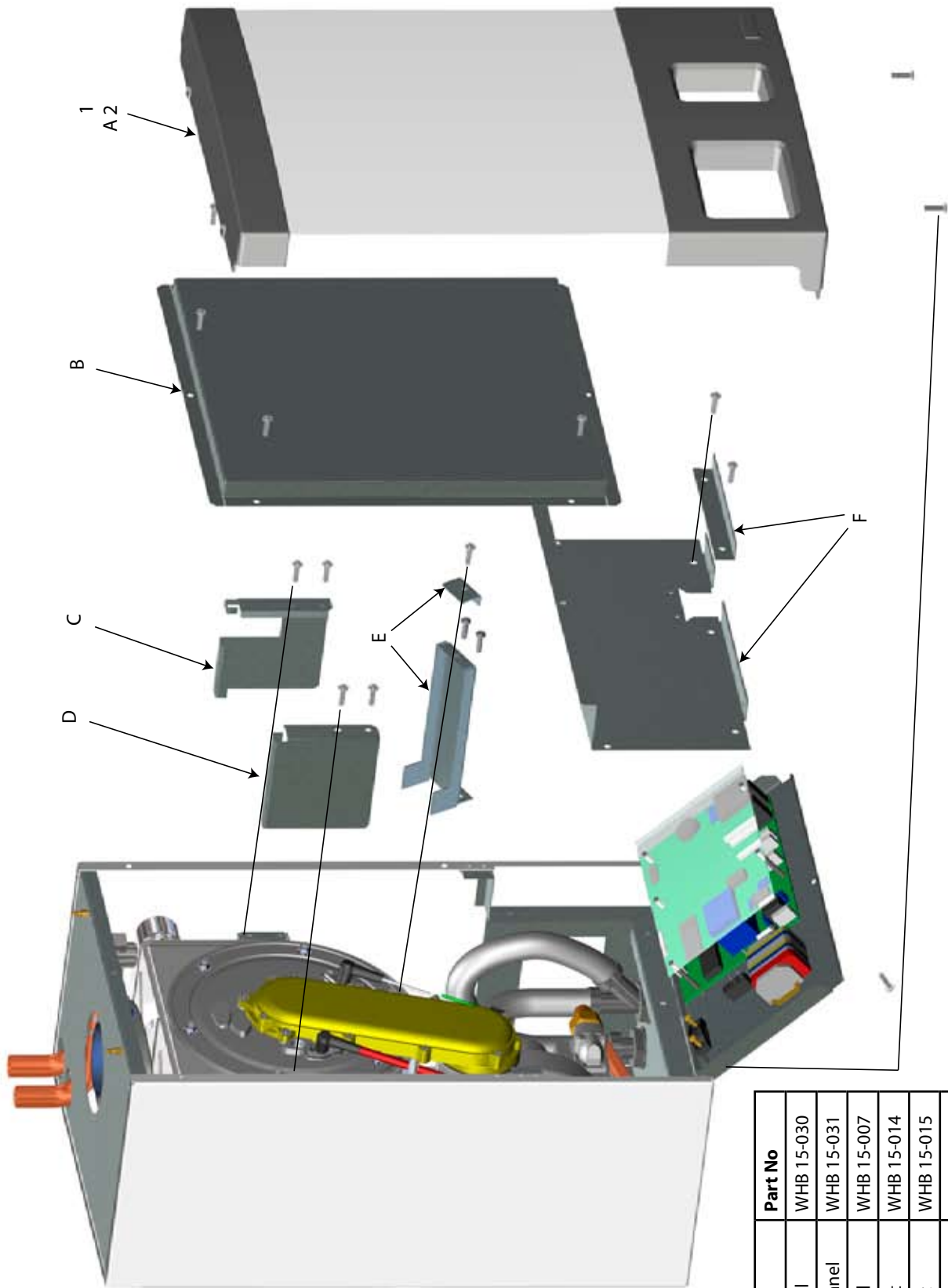

Key	Description	Part No
A1	White front panel	WHB 15-030
A2	Stainless front panel	WHB 15-031
B	Boiler front panel	WHB 15-007
C	RH boiler bracket	WHB 15-014
D	LH boiler bracket	WHB 15-015
E	Bottom boiler bracket	WHB 15-006.2
F	Lower boiler front panel	WHB 15-004

REPLACEMENT OF PARTS

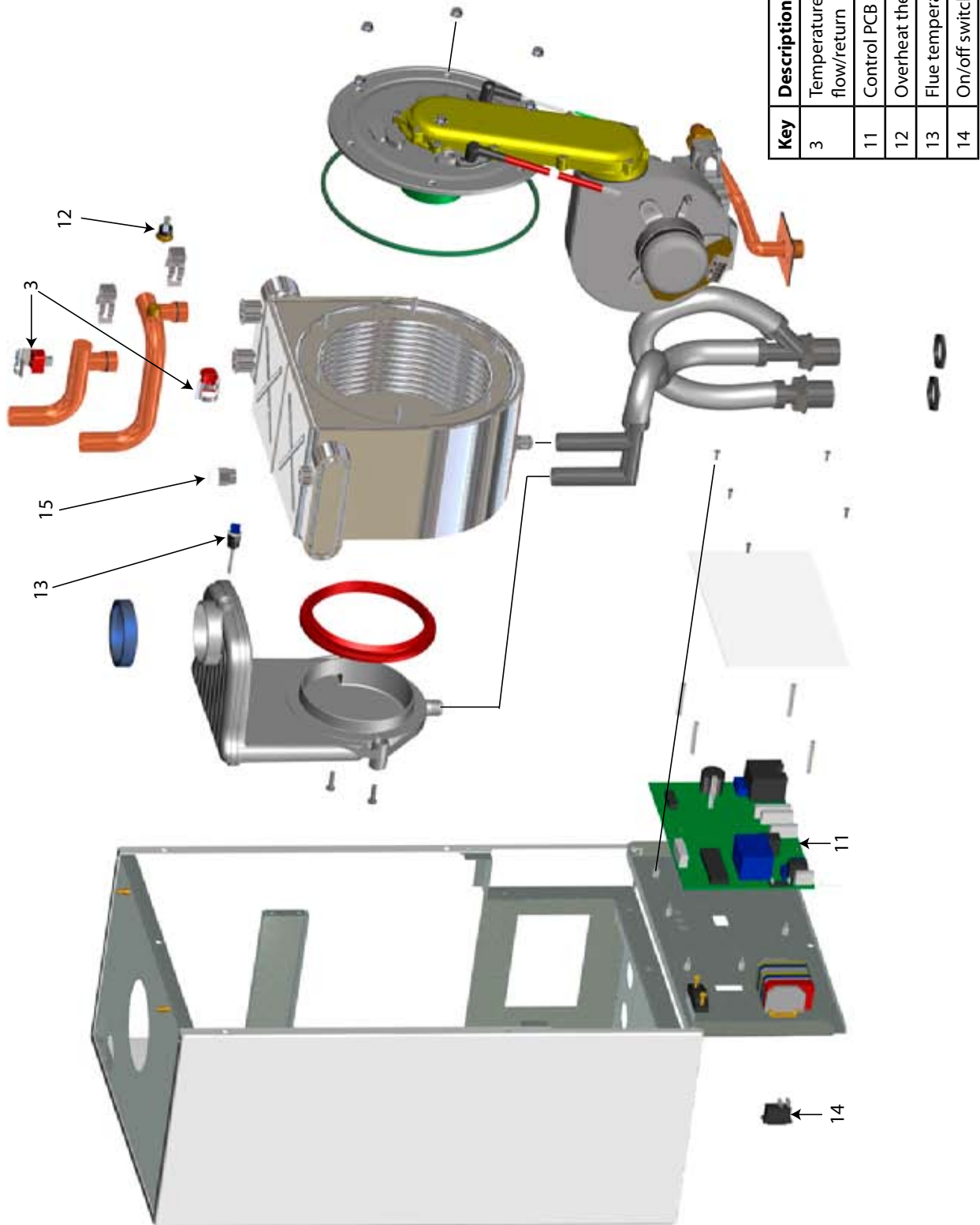

Key	Description	Part No
3	Temperature sensors flow/return	GT333
11	Control PCB	GT107
12	Overheat thermostat	GT455
13	Flue temperature sensor	GT334
14	On/off switch	GT034

REPLACEMENT OF PARTS

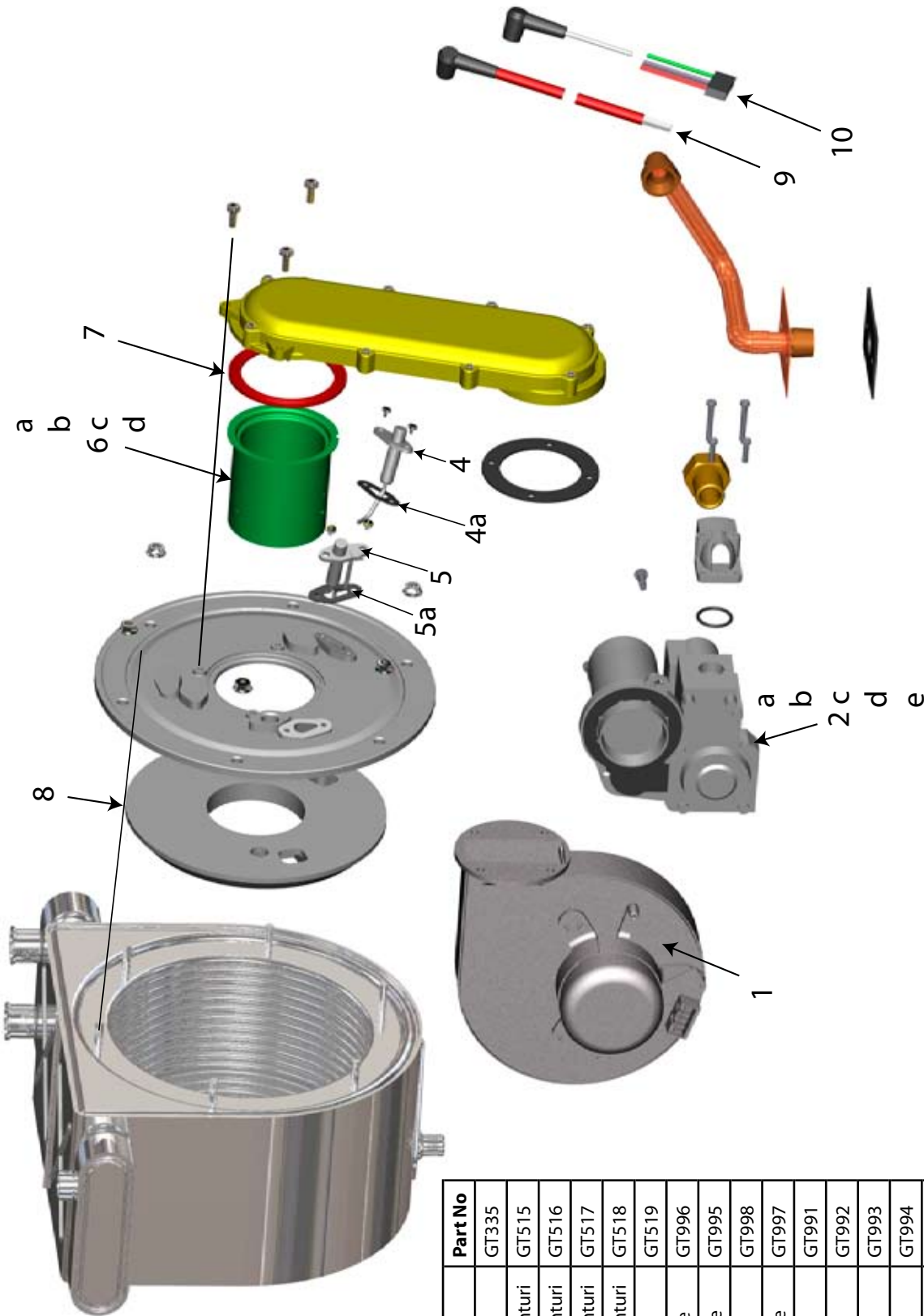

Part No	Description
1	Fan
2a	GB10 Gas Valve/Venturi
2b	GB15 Gas Valve/Venturi
2c	GB20 Gas Valve/Venturi
2d	GB25 Gas Valve/Venturi
2e	Gas Valve/Venturi
4	Ionisation Electrode
4a	Gasket for Electrode
5	Ignition Electrode
5a	Gasket for Electrode
6a	GB10 Burner
6b	GB15 Burner
6c	GB20 Burner
6d	GB25 + 30 Burner
7	Gasket for all Burners
8	Boiler insulation
9	Ignition lead
10	Flame sensing lead

SPARE PARTS

Key No	Part Number	Description	GC No
5	GT998	Ignition electrode	
5a	GT997	Gasket for electrode	
4	GT996	Ionisation electrode	
4a	GT995	Gasket for electrode	
6d	GT994	Burner GB-25, GB-30	
6c	GT993	Burner GB-20	
6b	GT992	Burner GB-15	
6a	GT991	Burner GB-10	
7	GT990	Gasket (for burner) – All models	
8	GT989	Boiler door insulation	
9	GT451	Ignition lead	
10	CA061	Flame sensing lead	
1	GT335	Fan assembly	
11	GT107	Control PCB	
3	GT333	Temperature sensors (flow & return)	
12	GT455	Overheat thermostat	
14	GT034	On-Off switch	
	GF199	Terminal guard	
2a	GT515	Gas Valve and Venturi assembly for GB-10	
2b	GT516	Gas Valve and Venturi assembly for GB-15	
2c	GT517	Gas Valve and Venturi assembly for GB-20	
2d	GT518	Gas Valve and Venturi assembly for GB-25	
2e	GT519	Gas Valve and Venturi assembly for GB-30	
13	GT334	Flue temperature sensor	

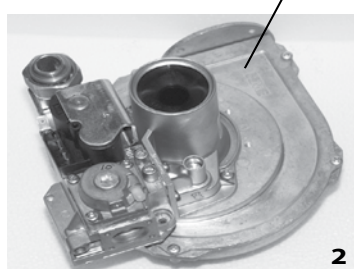



BENCHMARK No. | | | | | | |

GAS BOILER COMMISSIONING CHECKLIST

BOILER SERIAL No. _____ NOTIFICATION No. _____

CONTROLS To comply with the Building Regulations, each section must have a tick in one or other of the boxes

TIME & TEMPERATURE CONTROL TO HEATING	ROOM T/STAT & PROGRAMMER/TIMER <input type="checkbox"/>	PROGRAMMABLE ROOMSTAT <input type="checkbox"/>
TIME & TEMPERATURE CONTROL TO HOT WATER	CYLINDER T/STAT & PROGRAMMER/TIMER <input type="checkbox"/>	COMBI BOILER <input type="checkbox"/>
HEATING ZONE VALVES	FITTED <input type="checkbox"/>	NOT REQUIRED <input type="checkbox"/>
HOT WATER ZONE VALVES	FITTED <input type="checkbox"/>	NOT REQUIRED <input type="checkbox"/>
THERMOSTATIC RADIATOR VALVES	FITTED <input type="checkbox"/>	
AUTOMATIC BYPASS TO SYSTEM	FITTED <input type="checkbox"/>	NOT REQUIRED <input type="checkbox"/>

FOR ALL BOILERS CONFIRM THE FOLLOWING

THE SYSTEM HAS BEEN FLUSHED IN ACCORDANCE WITH THE BOILER MANUFACTURER'S INSTRUCTIONS?

THE SYSTEM CLEANER USED _____

THE INHIBITOR USED _____

FOR THE CENTRAL HEATING MODE, MEASURE & RECORD

GAS RATE m³/hr ft³/hr

BURNER OPERATING PRESSURE (IF APPLICABLE) N/A mbar

CENTRAL HEATING FLOW TEMPERATURE °C

CENTRAL HEATING RETURN TEMPERATURE °C

FOR COMBINATION BOILERS ONLY

HAS A WATER SCALE REDUCER BEEN FITTED? YES NO

WHAT TYPE OF SCALE REDUCER HAS BEEN FITTED? _____

FOR THE DOMESTIC HOT WATER MODE, MEASURE & RECORD

GAS RATE m³/hr ft³/hr

MAXIMUM BURNER OPERATING PRESSURE (IF APPLICABLE) N/A mbar

COLD WATER INLET TEMPERATURE °C

HOT WATER OUTLET TEMPERATURE °C

WATER FLOW RATE lts/min

FOR CONDENSING BOILERS ONLY CONFIRM THE FOLLOWING

THE CONDENSATE DRAIN HAS BEEN INSTALLED IN ACCORDANCE WITH THE MANUFACTURER'S INSTRUCTIONS? YES

FOR ALL INSTALLATIONS CONFIRM THE FOLLOWING

THE HEATING AND HOT WATER SYSTEM COMPLIES WITH CURRENT BUILDING REGULATIONS

THE APPLIANCE AND ASSOCIATED EQUIPMENT HAS BEEN INSTALLED AND COMMISSIONED IN ACCORDANCE WITH THE MANUFACTURER'S INSTRUCTIONS

IF REQUIRED BY THE MANUFACTURER, HAVE YOU RECORDED A CO/CO₂ RATIO READING? N/A YES CO/CO₂ RATIO

THE OPERATION OF THE APPLIANCE AND SYSTEM CONTROLS HAVE BEEN DEMONSTRATED TO THE CUSTOMER

THE MANUFACTURER'S LITERATURE HAS BEEN LEFT WITH THE CUSTOMER

COMMISSIONING ENG'S NAME PRINT _____ CORGI ID No. _____

SIGN _____ DATE _____

CONDENSING BOILER

SERVICE INTERVAL RECORD

It is recommended that your heating system is serviced regularly
and that you complete the appropriate Service Interval Record Below.

Service Provider. Before completing the appropriate Service Interval Record below, please ensure you have carried out the service as described in the boiler manufacturer's instructions. Always use the manufacturer's specified spare part when replacing all controls

SERVICE 1 DATE _____
ENGINEER NAME _____
COMPANY NAME _____
TEL No. _____
CORGI ID CARD SERIAL No. _____
COMMENTS _____
SIGNATURE _____

SERVICE 2 DATE _____
ENGINEER NAME _____
COMPANY NAME _____
TEL No. _____
CORGI ID CARD SERIAL No. _____
COMMENTS _____
SIGNATURE _____

SERVICE 3 DATE _____
ENGINEER NAME _____
COMPANY NAME _____
TEL No. _____
CORGI ID CARD SERIAL No. _____
COMMENTS _____
SIGNATURE _____

SERVICE 4 DATE _____
ENGINEER NAME _____
COMPANY NAME _____
TEL No. _____
CORGI ID CARD SERIAL No. _____
COMMENTS _____
SIGNATURE _____

SERVICE 5 DATE _____
ENGINEER NAME _____
COMPANY NAME _____
TEL No. _____
CORGI ID CARD SERIAL No. _____
COMMENTS _____
SIGNATURE _____

SERVICE 6 DATE _____
ENGINEER NAME _____
COMPANY NAME _____
TEL No. _____
CORGI ID CARD SERIAL No. _____
COMMENTS _____
SIGNATURE _____

SERVICE 7 DATE _____
ENGINEER NAME _____
COMPANY NAME _____
TEL No. _____
CORGI ID CARD SERIAL No. _____
COMMENTS _____
SIGNATURE _____

SERVICE 8 DATE _____
ENGINEER NAME _____
COMPANY NAME _____
TEL No. _____
CORGI ID CARD SERIAL No. _____
COMMENTS _____
SIGNATURE _____

SERVICE 9 DATE _____
ENGINEER NAME _____
COMPANY NAME _____
TEL No. _____
CORGI ID CARD SERIAL No. _____
COMMENTS _____
SIGNATURE _____

SERVICE 10 DATE _____
ENGINEER NAME _____
COMPANY NAME _____
TEL No. _____
CORGI ID CARD SERIAL No. _____
COMMENTS _____
SIGNATURE _____



Gledhill (Water Storage) Ltd

AMD, JUNE 2008

CONDITIONS OF SALE & GUARANTEE TERMS

1. Gledhill (Water Storage) Ltd ("We" or "Gledhills") only do business upon the Conditions which appear below and no other. Unless we so agree in writing these Conditions shall apply in full to any supply of goods by us to the exclusion of any Conditions or terms sought to be imposed by any purchaser. These Conditions of Sale and Warranty Terms override those which are contained on the Invoice Forms and all Sales are now subject to these Conditions of Sale and Warranty terms only.

2. PRICE

Once an order or call off has been accepted the price will be held for three months **but if delivery is extended beyond that period at the customer's request, then we reserve the right to amend the price when necessary.**

The company reviews its pricing annually to adjust for changes in our cost base. We reserve the right to alter prices at any time for severe movements in raw materials (mainly copper and steel). If there is to be a change we will give customers at least **four weeks** notice but **anything delivered** after that date will be at the revised price. An order may not be cancelled or varied after acceptance without the written consent of the company. Such cancellation or variation shall be subject to such reasonable charges as may be appropriate.

3. SPECIFICATION

The goods are supplied in accordance with the Specifications (if any) submitted to the Purchaser and any additions and alterations shall be the subject of an extra charge. Any goods not so specified shall be in accordance with our printed literature or the literature of any of our component suppliers (subject to any modifications made since publication). If we adopt any changes in construction or design of the goods, or in the specification printed in our literature, the Purchaser shall accept the goods so changed in fulfilment of the order.

4. PAYMENT

The invoice price of goods shall be payable within 30 days of despatch by us of our invoice for the goods or such longer time as may be stated by our quotation or invoice. If we receive payment in full on or before the due date we will allow an appropriate settlement discount except where we have quoted a special net price. If payment is not received in full on or before the due date we shall be entitled in addition to the invoice price to:

- (i) payment of a sum equal to any increase in the copper price supplement applicable to the particular goods sold between the date of receipt of order and the date of receipt of payment in full; and
- (ii) interest on any part of the invoice price unpaid after the due date at the rate of 3% per annum over the base rate for the time being of HSBC Bank plc.

5. TIME

We give estimates of delivery dates in good faith and time of delivery is not nor shall be made of the essence of any contract nor shall we be liable for any loss or damage occasioned by delay in delivery.

6. DELIVERY

We deliver free normally by our own vehicles within 25 miles of any of our manufacturing depots. Delivery to any place more than 25 miles from one of our manufacturing depots may be subject to our quoted delivery charges. We reserve the right to make delivery of goods contained in one order by more than one consignment and at different times. Where a period is agreed for delivery and such period is not extended by our Agreement, the Purchaser shall take delivery within that period. If the Purchaser fails to take delivery, we shall be entitled at the Purchaser's risk and expense to store the goods at the Purchaser's premises or elsewhere and to demand payment as if they had been despatched. Off loading at point of delivery shall be the responsibility of and be undertaken by the Purchaser.

7. SHORTAGES OR DAMAGE

Goods must be inspected before signature of delivery note and any damage, shortage or discrepancy noted on the delivery note and the goods returned on the same vehicle. The buyer must also give us immediate written notice of the damage, shortage or discrepancy so that we may prompt investigation.

8. RETURN OF GOODS

Goods may not be returned to the Company except by prior written permission of an authorised officer of the Company and such return shall be subject to payment by the Purchaser of handling and re-stocking charges, transport and all other costs incurred by the Company.

9. COMPANY LIABILITY AND GUARANTEE

9.1. Subject to the terms of these Conditions of Sale and Guarantee Terms Gledhills provide Guarantees in respect of specific products as set out in this clause.

9.2. Each Guarantee is strictly conditional upon the following:-

9.2.1. Complaints must be given to us immediately, before any action is taken, as responsibility cannot be accepted if repairs or renewals are attempted on site without our written approval.

9.2.2. The unit has been installed in accordance with our installation and service instructions and all relevant codes of practice and regulations in force at the time of installation.

9.2.3. All necessary inlet controls and safety valves have been fitted correctly.

9.2.4. The unit has only been used for the storage of potable water supplied from the public mains.

9.2.5 Where appropriate the unit has been regularly maintained as detailed in the installation and service instructions

9.2.6. Defects caused by corrosion or scale deposits are not covered by any Guarantee.

9.2.7. Where we agree to rectify any defect we reserve the right to undertake the work on our own premises.

9.3. Guarantees are provided in respect of specified goods supplied by Gledhills as follows:-

(a) Domestic and Commercial Open Vented Cylinders and Tanks.

The copper storage vessel is guaranteed for ten years and if it proves to be defective either in materials or workmanship, we will either repair or supply replacement at our option with the closest substitute in the case of any obsolete product to any address in Great Britain.

(i) free of all charge during the first year after delivery by us.

(ii) thereafter at a charge of one-tenth of the then current list price and any copper price supplement and delivery charge during the second year after delivery by us and increasing by a further one-tenth on the second and subsequent anniversary of delivery by us.

(b) Domestic Mains Fed Products [Primary Stores]

The copper storage vessel is guaranteed for five years and if it or any integral pipework as part of the storage vessel assembly proves to be defective either in materials or workmanship, we reserve the right to either repair or supply replacements or the closest possible substitute in the case of any obsolete product and will collect and deliver to any address in England, Wales and Scotland (excluding all Scottish Islands).

(i) free of all charge during the first year after delivery by us.

(ii) thereafter at a charge of one-fifth of the then current list price or any copper price supplement and delivery charge during the second year after delivery by us increasing by a further one-fifth on the second and subsequent anniversary of delivery by us.

(c) Integrated Boiler and Storage Vessel Products and Stand Alone Boilers

In the case of the GulfStream range of products and the Gledhill boiler range of products, Gledhill guarantees the heat exchanger (boiler) for material and construction faults for two years. THE RESPONSIBILITY FOR THE EXECUTION OF THIS GUARANTEE LIES WITH THE INSTALLER.

The guarantee becomes null and void if the appliance is used incorrectly, or in the event of proven negligence or incorrectly implemented repairs **OR FAILURE TO CARRY OUT THE RECOMMENDED INSPECTION/ MAINTENANCE.** The guarantee also becomes null and void if changes are made to the appliance without our knowledge, or if the serial number on the appliance is removed or made illegible.

The annual service must be carried out by a competent installer in accordance with the advice given by Gledhill and using Gledhill approved parts.

(d) Stainless Steel Unvented Cylinders

Gledhill guarantee the components including controls, valves and electrical parts for two years from the date of purchase. IT SHOULD BE NOTED THAT THE FACTORY FITTED TEMPERATURE AND PRESSURE RELIEF VALVE MUST NOT BE REMOVED OR ALTERED IN ANY WAY OR THE GUARANTEE WILL NOT BE VALID. GLEDHILL WILL NOT BE RESPONSIBLE FOR ANY CONSEQUENTIAL LOSS OR DAMAGE HOWEVER IT IS CAUSED.

The guarantee for the stainless steel vessel is for twenty five years if the original unit is returned to us **AND PROVIDED THAT:**

(i) It has been installed as per the Design, Installation & Servicing Instructions, relevant standards, regulations and codes of practice.

(ii) It has not been modified, other than by Gledhill.

(iii) It has not been subjected to wrong or improper use or left uncared for.

(iv) It has only been used for the storage of potable water.

(v) It has not been subjected to frost damage.

(vi) The benchmark log book is completed after each annual service.

(vii) The unit has been serviced annually.

It should be noted that the guarantee does not cover:

- the effects of scale build up

- any labour charges associated with replacing the unit or parts.

If the stainless steel vessel proves to be defective either in materials or workmanship we reserve the right to either repair or supply replacements or the closest possible substitute in the case of any obsolete product and will collect and deliver to any address in England, Scotland and Wales (excluding all islands):

(i) free of charge during the first year after delivery by us.

(ii) thereafter at a charge of one twenty fifth of the then current list price during the second year after delivery by us and increasing by a further one twenty fifth on the second and subsequent anniversary of delivery by us.

ACTION IN THE EVENT OF FAILURE

If the stainless steel cylinder develops a leak we will ask for a deposit against the supply of a new one. This will be refunded if the failure is within the terms of the warranty when it has been examined by us.

(e) Solar Panels and ancillary equipment

Gledhill provides a five year warranty for defects in the collectors (except broken glass and collector accessories eg metal edgings). If the collector demonstrably fails to meet one of the requirements of the standard DIN 4757 part 3 we will replace it free of charge based on the date of invoice. We can not be responsible for damage caused by mechanical stress and/or changes caused by weather related influences. The warranty excludes minor surface damage that does not affect performance or malfunction due to improper assembly or installation.

Please note:

- Installation must have been carried out by a licensed specialized company (heating contractor or plumber) following the version of installation instructions in force.

- Gledhill or its representative was given the opportunity to check complaints on site immediately after any defect occurred.

- Confirmation exists that the system was commissioned properly and that the system was checked and maintenance was performed annually by a specialised company licensed for this purpose.

(f) Components of our products other than Storage Vessels and Integral Pipework.

We will either extend to the purchaser the same terms of warranty as we are given by the manufacturer of the component or if the manufacturer does not give any warranty, replace free of charge any component which becomes defective within two years after the date of the delivery by us and is returned to us at the purchaser's expense but we shall not meet the cost of removal or shipping or return of the component or any other cost charges or damages incurred by the purchaser.

If the appliance manufactured by Gledhill incorporates a factory fitted scale inhibitor then during the period

of three years from the date of delivery Gledhill will replace, free of charge, any plate heat exchanger fitted in the appliance as original equipment in which scale formation occurs that materially reduces the effectiveness of the plate heat exchanger. This guarantee does not extend to any other component installed within the Gledhill appliance or elsewhere in the Purchaser's domestic water system.

9.4.

9.4.1. In respect of goods supplied by us and in respect of any installation work carried out by or on our behalf, our entire liability and the purchaser's sole remedies (subject to the Guarantees) shall be as follows:-

- (a) We accept liability for death or personal injury to the extent that it results from our negligence or that of our employees
- (b) Subject to the other provisions of this clause 9 we accept liability for direct physical damage to tangible property to the extent that such damage is caused by our negligence or that of our employees, agents or subcontractors.
- (c) Our total liability to the purchaser over and above any liability to replace under the Guarantees (whether in contract or in tort including negligence) in respect of any one cause of loss or damage claimed to result from any breach of our obligations hereunder, shall be limited to actual money damages which shall not exceed £20,000 provided that such monetary limit shall not apply to any liability on the part of ourselves referred to in paragraph (a) above
- (d) Except as provided in paragraph (a) above but otherwise notwithstanding any provision herein contained in no event shall we be liable for the following loss or damage howsoever caused and even if foreseeable by us or in our contemplation:-
 - (i) economic loss which shall include loss of profits, business revenue, goodwill or anticipated savings
 - (ii) damages in respect of special indirect or consequential loss or damage (other than death, personal injury and damage to tangible property)
 - (iii) any claim made against the purchaser by any other party (save as expressly provided in paragraph (b) above)
- (e) Except in respect of our liability referred to in paragraph (a) above no claim may be made or action brought (whether in contract or in tort including negligence) by the purchaser in respect of any goods supplied by us more than one year after the date of the invoice for the relevant goods.
- (f) Without prejudice to any other term we shall not be liable for any water damage caused directly or indirectly as a result of any leak or other defect in the goods. We cannot control the conditions of use of the goods or the time or manner or location in which they will be installed and the purchaser agrees to be fully responsible for testing and checking all works which include the goods at all relevant times (up to, including and after commissioning) and for taking all necessary steps to identify any leaks and prevent any damage being caused thereby.
- (g) Nothing in these Conditions shall confer on the purchaser any rights or remedies to which the purchaser would not otherwise be legally entitled

10. LOSS OR INJURY

Notwithstanding any other provision contained herein the purchaser's hereby agree to fully indemnify us against any damages losses costs claims or expenses incurred by us in respect of any claim brought against us by any third party for:-

- (a) any loss injury or damage wholly or partly caused by any goods supplied by us or their use.
- (b) any loss injury or damage wholly or partly caused by the defective installation or substandard workmanship or materials used in the installation of any goods supplied by us.
- (c) any loss injury or damage in any way connected with the performance of this contract.
- (d) any loss resulting from any failure by the purchaser to comply with its obligations under these terms as to install and/or check works correctly.

PROVIDED that this paragraph will not require the purchaser to indemnify us against any liability for our own acts of negligence or those of our employees agents or sub-contractors

FURTHER in the case of goods supplied by us which are re-sold and installed by a third party by the purchaser it will be the sole responsibility of the purchaser to test the goods immediately after their installation to ensure that inter alia they are correctly installed and in proper working order free from leaks and are not likely to cause any loss injury or damage to any person or property.

11. VARIATION OF WARRANTY AND EXCLUSION

Should our warranty and exclusion be unacceptable we are prepared to negotiate for variation in their terms but only on the basis of an increase in the price to allow for any additional liability or risk which may result from the variation.

Purchasers are advised to insure against any risk or liability which they may incur and which is not covered by our warranty.

12. RISK AND RETENTION OF TITLE

- (a) goods supplied by us shall be at the Purchaser's risk immediately upon delivery to the Purchaser or into custody on the Purchaser's behalf or to the Purchaser's Order. The Purchaser shall effect adequate insurance of the goods against all risks to the full invoice value of the goods, such insurance to be effective from the time of delivery until property in the goods shall pass to the Purchaser as hereinafter provided.
- (b) property in the goods supplied hereunder will pass to the Purchaser when full payment has been made by the Purchaser to us for :-
 - (i) the goods of the subject of this contract.
 - (ii) all other goods the subject to of any other contract between the Purchaser and us which, at the time of payment of the full price of the goods sold under this contract, have been delivered to the Purchaser but not paid for in full.
- (c) until property in the goods supplied hereunder passes to the Purchaser in accordance with paragraph (2) above.
 - (i) the Purchaser shall hold the goods in a fiduciary capacity for us and shall store the same separately from any other goods in the Purchaser's possession and in a manner which enables them to be identified as our goods.
 - (ii) the Purchaser shall immediately return the goods to us should our authorised representative so request. All the necessary incidents associated with a fiduciary relationship shall apply.
- (d) the Purchaser's right to possess the goods shall cease forthwith upon the happening of any of the following events, namely :-
 - (i) if the Purchaser fails to make payment in full for the goods within the time stipulated in clause 4 hereof.
 - (ii) if the Purchaser, not being a company, commits any act of bankruptcy, makes a proposal to his or her creditors for a compromise or does anything which would entitle a petition for a Bankruptcy Order to be presented.
 - (iii) if the Purchaser, being a company, does anything or fails to do anything which would entitle an administrator or an administrative receiver or a receiver to take possession of any assets or which would entitle any person to present a petition for winding up or to apply for an administration order.
- (e) the Purchaser hereby grants to us an irrevocable licence to enter at any time any vehicle or premises owned or occupied by the Purchaser or in the possession of the Purchaser for the purposes of repossessing and

recovering any such goods the property in which has remained in us under paragraph (2) above. We shall not be responsible for and the Purchaser will indemnify us against liability in respect of damage caused to any vehicle or premises in such repossession and removal being damaged which it was not reasonably practicable to avoid.

- (f) notwithstanding paragraph (3) hereof and subject to paragraph (7) hereof, the Purchaser shall be permitted to sell the goods to third parties in the normal course of business. In this respect the Purchaser shall act in the capacity of our commission agent and the proceeds of such sale :-
 - (i) shall be held in trust for us in a manner which enables such proceeds to be identified as such, and:
 - (ii) shall not be mixed with other monies nor paid into an overdrawn bank account.

We, as principal, shall remunerate the Purchaser as commission agent a commission depending upon the surplus which the Purchaser can obtain over and above the sum, stipulated in this contract of supply which will satisfy us.

- (g) in the event that the Purchaser shall sell any of the goods pursuant to clause (6) hereof, the Purchaser shall forthwith inform us in writing of such sale and of the identity and address of the third party to whom the goods have been sold.

- (h) if, before property in the goods passes to the Purchaser under paragraph (2) above the goods are or become affixed to any land or building owned by the Purchaser it is hereby agreed and declared that such affixation shall not have the effect of passing property in the goods to the Purchaser. Furthermore if, before property in the goods shall pass to the Purchaser under paragraph (2) hereof, the goods are or become affixed to any land or building (whether or not owned by the Purchaser), the Purchaser shall:-

- (i) ensure that the goods are capable of being removed without material injury to such land or building.
- (ii) take all necessary steps to prevent title to the goods from passing to the landlord of such land or building.
- (iii) forthwith inform us in writing of such affixation and of the address of the land or building concerned.

The Purchaser warrants to repair and make good any damage caused by the affixation of the goods to or their removal from any land or building and to indemnify us against all loss damage or liability we may incur or sustain as a result of affixation or removal.

- (i) in the event that, before property in the goods has passed to the Purchaser under paragraph (2) hereof, the goods or any of them are lost, stolen, damaged or destroyed :-
- (ii) the Purchaser shall forthwith inform us in writing of the fact and circumstances of such loss, theft, damage or destruction.
- (iii) the Purchaser shall assign to us the benefit of any insurance claim in respect of the goods so lost, stolen, damaged or destroyed.

13. NON-PAYMENT

If the Purchaser shall fail to make full payment for the goods supplied hereunder within the time stipulated in clause 4 hereof or be in default of payment for any other reason then, without prejudice to any of our other rights hereunder, we shall be entitled to stop all deliveries of goods and materials to the Purchaser, including deliveries or further deliveries of goods under this contract. In addition we shall be entitled to terminate all outstanding orders.

14. VALUE ADDED TAX

All prices quoted are exclusive of Value Added Tax which will be charged at the rate ruling at the date of despatch of invoice.

15. TRADE SALES ONLY

We are only prepared to deal with those who are not consumers within the terms of the Unfair Contract Terms Act 1977, the Sale of Goods Act 1979 and the Supply of Goods and Services Act 1982. Accordingly any person who purchases from us shall be deemed to have represented that he is not a consumer by so purchasing.

16. JURISDICTION

The agreement is subject to English law for products delivered in England and Scottish law for products delivered in Scotland and any dispute hereunder shall be settled in accordance therewith dependent upon the location.

