

REXGEAR

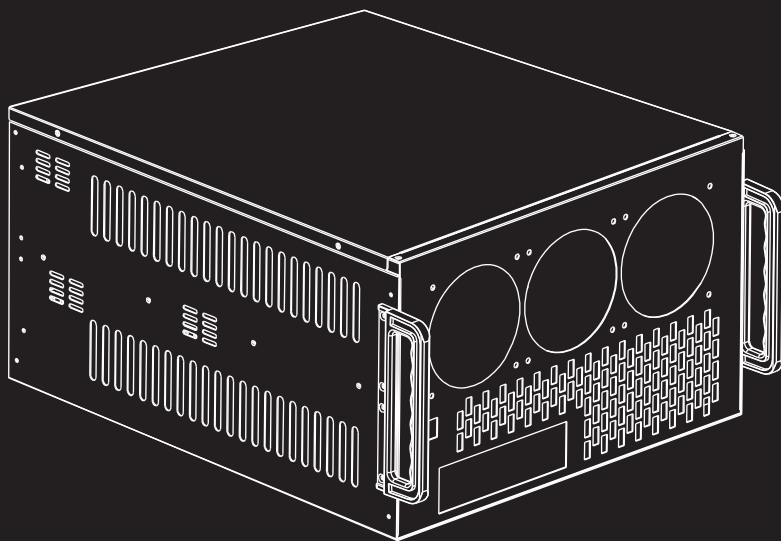









Bitcoin Machine Case

HYDRA-2

Quick User Guide 

Accessory Kit

Image	Part's Name	Qty	Function/Component
	Screw-A	26	PSU / VGA Card
	Screw-B	15	Motherboard / 3.5" HDD
	Screw-D	4	2.5" HDD / SSD
	Nut Setter	1	Stand Off
	Screw-F	26	Fans
	Rubber Grommet	4	Chassis
	Rubber Cushion	8	PSU
	Fan Grill	6	Finger Guard
	Cable Tie	4	Cable Management

HYDRA-2

Product Diagram

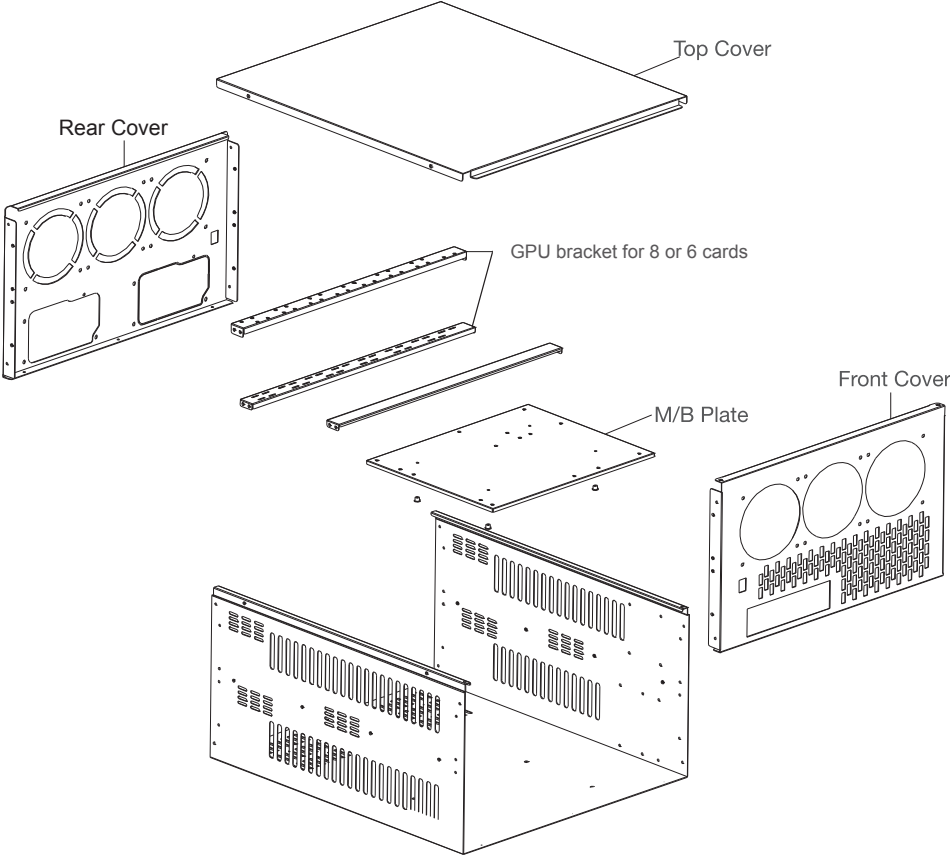

HYDRA-2

1. Remove the top panel

Remove four screws on the left and right side of the top panel

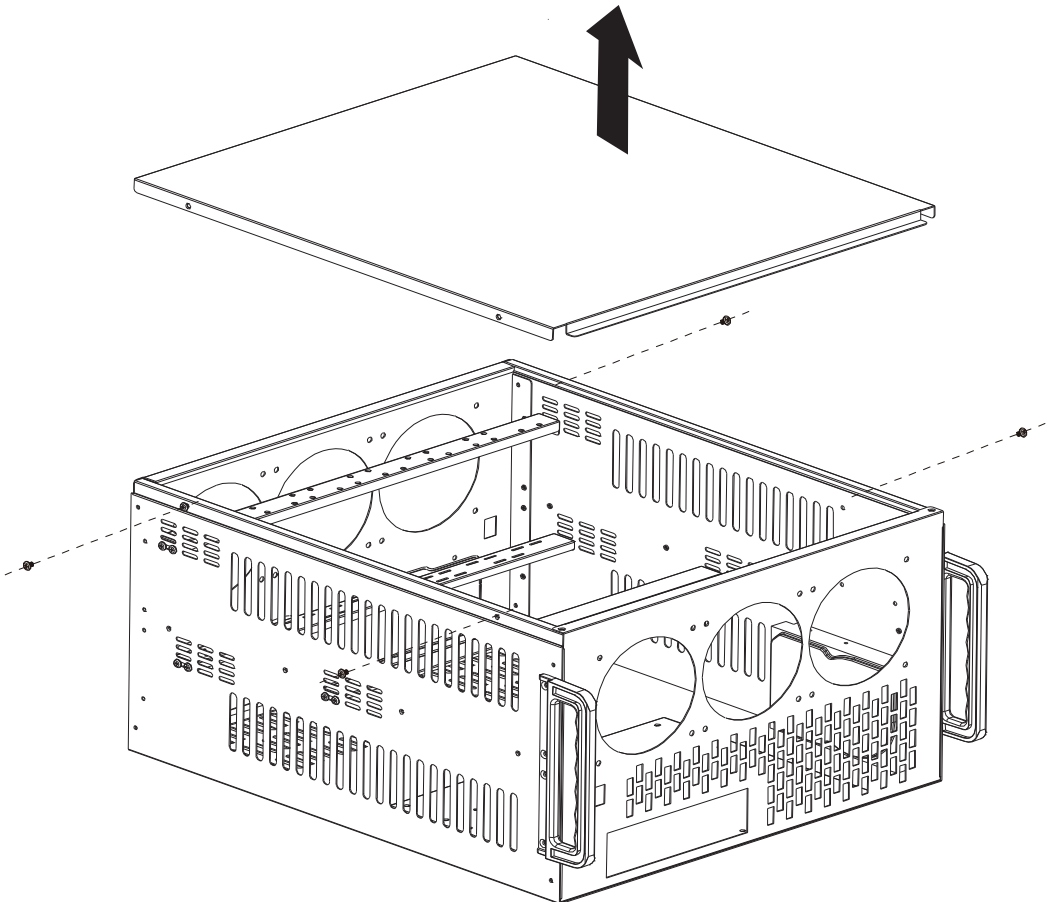

2. Install the fans

We recommend high speed server fans with greater than 4000 RPM and 150 CFM.
Generic case fans may not provide adequate static pressure for server environment.

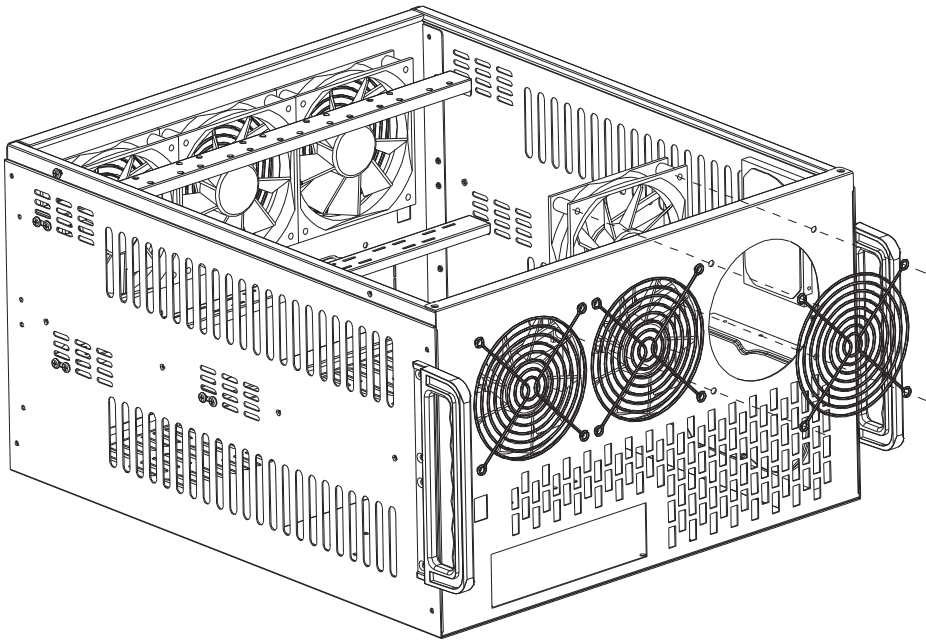

3. Install the power supplies

Use rubber cushions to minimize vibration

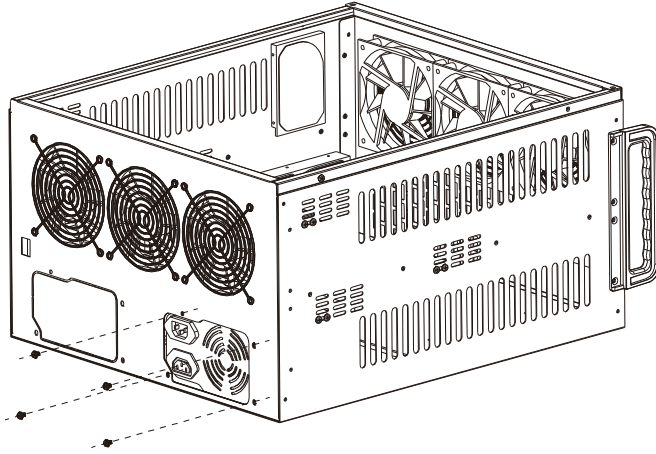

4. Install the motherboard

Stand offs are pre-installed in the chassis

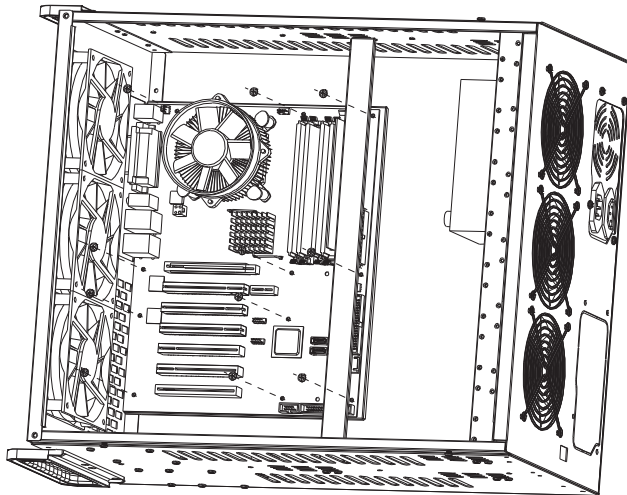

5. Install the HDD/SSD

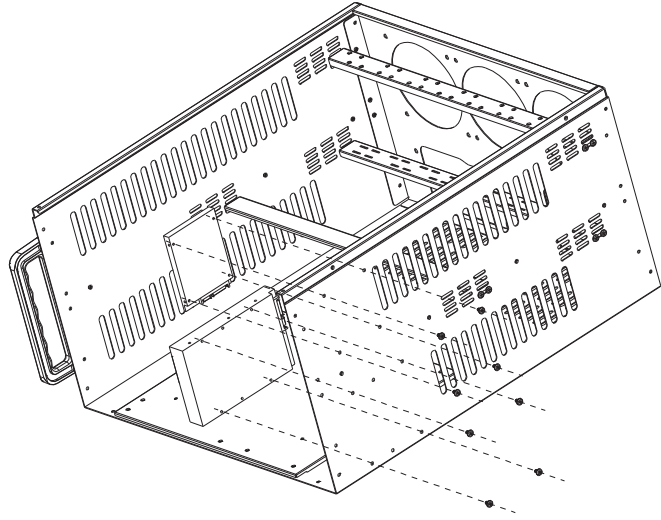

6. Install the add-on cards

This case is optimized for 8 dual slot aftermarket cards with bigger PCB/cooler up to 330 mm length and 150 mm height.

GPU brackets can be switched from 8 to 6 mounting patterns when only using 6 cards.

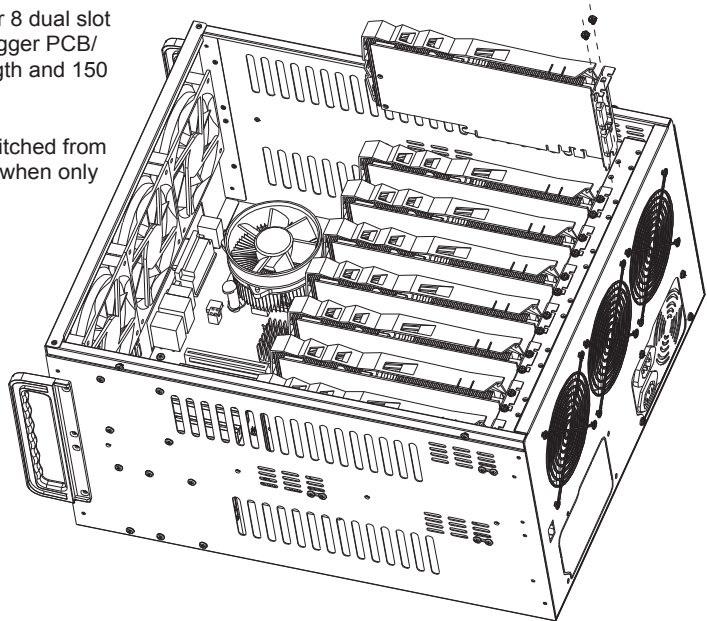

7. Close the top panel

A closed system is required to maintain positive pressure and front-to-back active airflow management. This prevents hot exhaust air from circulating back into the equipment intake.

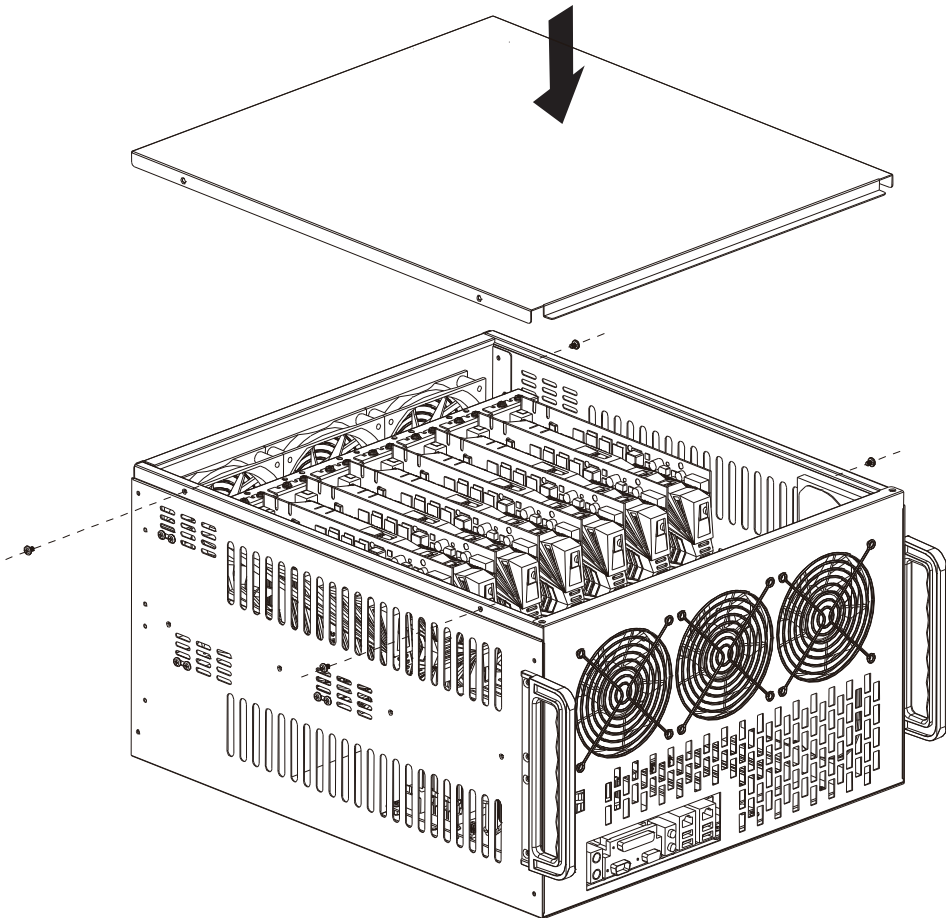

REXGEAR

support@rexgear.com

HYDRA-2