

MAGIKIST
MAGIKIST



MODEL HWG40
MODEL HWG20

GAS FIRED
COMMERCIAL
& INDUSTRIAL
PRESSURE
WASHER
HEATERS

INSTRUCTION
MANUAL
V3.02

For heaters equipped with
ProSafe II control and
24V electronic ignition
(HSI)
or 24V standing pilot



this page was intentionally left blank

TABLE OF CONTENTS

1.0	INTRODUCTION.....	1
2.0	IMPORTANT OPERATING CONDITIONS.....	2
3.0	SAFETY.....	2
4.0	INSTALLATION	
4.1	LOCATION.....	3
4.2	MOUNTING.....	3
4.3	GAS SUPPLY.....	3
4.4	VENTING.....	3
4.5	AUTOMATIC VENT DAMPER.....	3
4.6	POWER VENTER.....	4
4.7	FLOW SWITCH.....	4
4.8	INLET PLUMBING.....	4
4.9	OUTLET PLUMBING.....	4
4.10	ELECTRICAL CONNECTIONS.....	5
5.0	PRE-OPERATION CHECKS	
5.1	FLUSH DEBRIS FROM THE SYSTEM.....	7
5.2	INITIAL POWER UP.....	7
5.3	CHECK FLOW SWITCH & AUTOMATIC VENT DAMPER.....	7
5.4	BLEED OFF AIR.....	7
5.5	LIGHTING THE PILOT BURNER.....	7
5.6	CHECK IGNITION OF MAIN BURNERS.....	8
6.0	<i>PROSAFE II</i> CONTROL	
6.1	TEMPERATURE SETTING.....	9
6.2	POWER INDICATOR.....	10
6.3	HEAT ON INDICATOR.....	10
6.4	REQUEST FOR HEAT INDICATOR.....	10
6.5	PURGE DELAY ON INDICATOR.....	10
6.6	FLOW ON INDICATOR.....	10
6.7	THERMOSTAT INDICATOR.....	10
6.8	EXTERIOR CONTROL INDICATOR.....	10
6.9	FLUE STATUS INDICATOR.....	11
6.10	DAMPER OPEN INDICATOR.....	11
6.11	POWER VENT INDICATOR.....	11
7.0	<i>PROSAFE II</i> ERROR & WARNINGS	
7.1	ERROR CONDITIONS.....	12
7.2	WARNING CONDITIONS.....	12
8.0	ELECTRONIC IGNITION OPERATION.....	13
9.0	MAINTENANCE	
9.1	FLOW SWITCH.....	14
9.2	RELIGHTING THE PILOT BURNER.....	14
9.3	CARE OF MAIN BURNERS.....	14
9.4	CLEANING HEATER COIL OF SCALE.....	14
10.0	HELPFUL INFORMATION	
10.1	COIL CONDENSATION.....	15
10.2	COIL SCALING.....	15
10.3	FREEZING CONDITIONS.....	15
10.4	USE OF ACIDS.....	15
10.5	COIL TEST.....	15
10.6	TERMINAL CONNECTIONS TO <i>PROSAFE II</i>	15
11.0	TROUBLESHOOTING.....	16
	PARTS LIST.....	19
	WIRING DIAGRAM.....	21
11.0	SPECIFICATIONS.....	23

this page was intentionally left blank

1.0 INTRODUCTION

The HWG20 and HWG40 are steel coil type instantaneous hot water heaters suitable for any low or high pressure application requiring fast recovery. They are most suitable for high pressure wash systems where the high pressure water from the pump may be fed through the heater, thereby producing hot water while only cold water is run through the pump. They may also be used in combination with an insulated storage tank for a low pressure hot water system.

The durable stainless steel shell of the HWG20 and HWG40 withstands years of use and will not rust. Both models are available with either electronic ignition (HSI) or standing pilot. An automatic vent damper is available as an option from the factory to save energy and protect the heater coil from freezing conditions. In addition, a power venter is available as an option for sidewall venting of the heater.

The operation of the heater is controlled and monitored by the *PROSAFE II* industrial heater control, an advanced microcontroller that monitors several

aspects of the heater operation in order to provide safe and effective control of the heater. The *PROSAFE II* control provides visual status to the operator of the heater through a front panel display on the heater. Should some condition arise which results in the heater exceeding its normal operating temperature, the *PROSAFE II* control provides overheat lockout protection, thus protecting the heater and operator from the dangers of a heater overheat condition. The *PROSAFE II* control also provides coil protection via a coil freeze warning should the temperature in the flue ever drop near the freezing point. The *ProSafe II* control will effectively and safely control the optional automatic vent damper, eliminating open/close cycling while still providing maximum coil protection and energy savings. The *PROSAFE II* control will also directly control the optional power venter without requiring any additional timers or controls. An electronic sensor with digital display of the current water temperature is utilized to provide precise control of the outlet water temperature.

For future reference when ordering parts or requesting service information, please take a moment to record your heater model number and serial number which can be found on the certification plate mounted on the front of the heater.

Model#

Serial#

2.0 IMPORTANT OPERATING CONDITIONS

Failure to comply with any of these conditions invalidates the warranty.

Pressure - The water pressure supplied to the water inlet of the heater must never exceed the maximum water pressure rating of the heater. The pressure regulator supplied with the heater must remain installed on the heater.

Freezing Conditions - The heater must be protected from freezing conditions otherwise severe damage to the heater coil may result. Adequate air supply to the area housing the heater must be supplied to prevent the coil freezing from a reverse draft down the heater vent. If necessary, an automatic vent damper should be installed. See section 4.4 VENTING for further information.

Gas Installation- Gas piping and installation of these gas water heaters must be performed by qualified licensed personnel in accordance with CAN1-B149.1 & CAN1-B149.2 installation codes and/or local codes.

PROSAFE II Control - The heater control is not a user serviceable item. Do not remove the mounting screws holding the cover to the box.

Acids, Alkalies, or Abrasive Fluids - Consult factory before using heater with any of these fluids.

3.0 SAFETY

Your heater was designed and constructed with safety foremost. The following safety precautions should be taken with your heater:

- 1) Read and understand this manual before operating the equipment. Ensure that all operators of this heater are fully familiar with the operating and safety procedures contained in this manual. An untrained operator exposes him or herself as well as bystanders to potential harm.
- 2) Do not modify the equipment in any way. Unauthorized modification may impair the function and/or safety of the equipment creating a potential or real hazard to personnel.
- 3) The exterior of the heater may become hot during operation. Avoid contact with the exterior of the heater.
- 4) Do not smoke near the heater. Keep open flame and sparks away.

IF AT ANYTIME YOU SMELL GAS, SHUT OFF THE GAS SUPPLY TO THE HEATER, AND EXTINGUISH ANY OPEN FLAME. CALL YOUR GAS INSTALLER IMMEDIATELY.

If the heater is to be incorporated into a high pressure system, the safety procedures applicable to high pressure systems should be followed.

- 1) Always hold the gun and extension firmly in both hands during operation.
- 2) High pressure spray presents the risk of injection and severe injury. Always keep clear of the spray nozzle. Do not direct discharge stream at people or electrical apparatus.
- 3) Always keep clear of moving belts and pulleys.
- 4) Never disconnect high pressure hose during operation.

4.0 INSTALLATION

*** HEATERS MUST BE INSTALLED BY QUALIFIED PERSONNEL ONLY ***

4.1 LOCATION

- 1) The water heater contains sensitive electronic components that must not be exposed to water spray. Choose a location such that the heater will not be exposed to water spray of any kind. Failure to do so may result in damage to electronic components and void the warranty on such components.
- 2) The water heater is approved for installation on non-combustible material with 6 inches of clearance from combustible walls. A minimum clearance of 48 inches is required on the heater front for access.
- 3) The water heater must be located in an area that is protected from the weather and locations where flooding may occur. **Avoid drafty locations that may cause pilot outage.**
- 4) In repair garages, the point of ignition shall be not less than 4.5 feet (54 inches) above the floor.
- 5) The location of the heater should be in an area away from moving vehicles and should be provided with sufficient protection and support to prevent damage.
- 6) If the heater is being installed with a high pressure pump, the heater should be installed in a suitable dry location as near to the high pressure pump unit as practical to simplify connecting the water supply lines and electrical lines between the two units.

4.2 MOUNTING

The heater must be mounted to a solid, non-combustible base. Mounting holes are provided on the inside bottom of the heater. The HWG40 has four 1/2" holes while the HWG20 has three 1/2" holes.

4.3 GAS SUPPLY

- 1) Pipe sizing must conform to local and applicable codes (CGA B149.1 and B149.2).
- 2) Natural gas and LP (propane) heaters incorporate different components such that they are not interchangeable. Never supply LP (propane) to a natural gas heater or natural gas to a LP (propane) heater.

CAUTION: Unlike natural gas, LP (propane) gas is heavier than air. If pilot outage should occur, the floor areas should be vented and blown clear before relighting the pilot.

IMPORTANT:

Licensed gas installer **MUST** ensure:

- 3.5" W.C. for natural gas heaters or
- 11" W.C. using an external regulator for LP gas heaters

measured at the Pressure Tap Port on the gas valve as shown in figure 4.3.1.

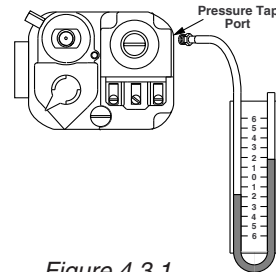

Figure 4.3.1

4.4 VENTING

- 1) Observe C.G.A. Standards B149.1 and B149.2 and local safety codes.
- 2) The draft hood furnished with the heater must be attached to the flue outlet without alteration using the same size vent as the draft hood outlet (see specifications for flue diameter).
- 3) For venting in general, do not reduce size of vent. Reductions in vent sizing for power venters must be made after the draft hood. For horizontal runs, maintain 1/4 inch pitch per foot. Top of stack to be 2 feet above highest part of roof or nearby obstructions. Provide an approved cap for the stack outlet. Refer to C.G.A. standards.
- 4) Use of type "B" venting is recommended and must be installed in accordance with C.G.A. standards B149.1 and B149.2 by qualified personnel.
- 5) Provisions for other water heaters and/or other gas fired appliances within the same enclosure as the heater must be made to allow for ample free air to enter the enclosure for combustion and venting. **Failure to supply adequate free air may result in the dangerous accumulation of combustion gas and/or severe damage to the heater coil, due to reverse drafting of air down the heater vent. If necessary, an automatic vent damper or power venter should be installed.**

4.5 AUTOMATIC VENT DAMPER

The following instructions, and all instructions in this manual pertaining to automatic vent dampers, refer to the Magikist model HWG-AD10 (for the HWG40) or the HWG-AD7 (for the HWG20) automatic vent dampers. Other vent dampers are neither approved nor tested for use with the HWG40 or the HWG20 heaters.

CAUTION: HWG40 and HWG20 heaters with 24 volt electronic ignition come equipped for installation of an automatic vent damper. Heaters with 24 volt standing pilot must have an additional or redundant gas valve installed. Refer to the appropriate C.G.A. standards and the instructions supplied with the automatic vent damper.

- 1) Observe C.G.A. Standards B149.1 and B149.2 and local safety codes.
- 2) Ensure that the service switch located on the motor housing of the automatic vent damper is at the "AUTOMATIC OPERATION" position. The "HOLD DAMPER OPEN" position is for service only.
- 3) The automatic vent damper must be wired according to the instructions in section 4.10 ELECTRICAL CONNECTIONS. **Failure to do so will result in incorrect operation of the automatic vent damper and a potentially dangerous condition.**
- 4) Read the manufacturer's manual provided with the automatic vent damper and ensure that all instructions are followed.

4.6 POWER VENTER

The following instructions, and all instructions in this manual pertaining to power venters, refer to the Magikist model HWG-PV6B-24 (for the HWG40) or the HWG-PV4B-24 (for the HWG20) power venters. Other power venters are neither approved nor tested for use with the HWG40 or the HWG20 heaters.

- 1) Observe C.G.A. Standards B149.1 and B149.2 and local safety codes.
- 2) The power venter must be wired according to the instructions in the separate document HWG-PV Power Venter Wiring Instructions. **Failure to do so will result in incorrect operation of the power venter and a potentially dangerous condition.**
- 3) Read the manufacturer's manual provided with the power venter and ensure that all instructions are followed.

4.7 FLOW SWITCH

Most heaters are supplied with a flow switch which you will find installed on the water inlet of the heater.

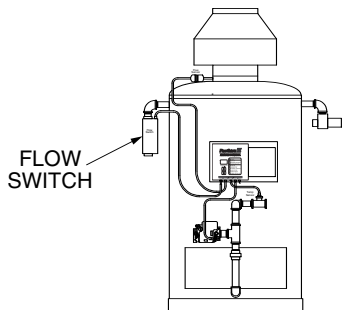

Figure 4.7.1

If your heater was supplied without a flow switch, one **must** be installed on the water inlet of the heater for correct operation of the heater. The flow switch must be a single pole, single throw, normally open switch capable of switching a minimum of 1 amp at 24 VAC. The switch must also have minimum flow rate of 1.0 U.S. gpm. For most applications where the high pressure output of a pump is to be fed directly through the flow switch into the water inlet of the heater, the maximum pressure and flow rating of the flow switch must meet or exceed the operating pressure and gallons per minute (GPM) of the pump.

4.8 INLET PLUMBING

When facing the front of the heater, the water inlet is located on the left, top side. If a flow switch was provided with your heater, the inlet is 3/8" FNPT connection. If a flow switch was not provided with your heater, the inlet is a 3/4" MNPT connection.

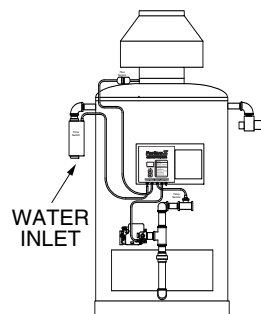

Figure 4.8.1

In most applications, the water inlet of the heater is connected to the high pressure outlet of a pump. In such cases, the direct connection to the water inlet of the heater from the pump must be made with high pressure hose rated for the operating pressure of the pump and the water outlet temperature of the heater. Your

heater is normally supplied with a short length of high pressure hose connected to the water inlet of the heater that you may use to attach to your inlet plumbing to. **Rigid piping must never be directly connected to the heater due to the potential damage that may result from pump vibration being transferred to the heater.**

The plumbing to the water inlet of the heater should be sized for the flow rate desired in order to prevent pressure loss. There should be no unnecessary restrictions in the inlet plumbing. Length should be kept to a minimum as should the number of elbows and joints. Teflon tape should be used to seal all joints.

4.9 OUTLET PLUMBING

When facing the front of the heater, the water outlet is located at the front, slightly to the right of the center on the HWG40 the HWG20. The water outlet is a 3/8" FNPT swivel connection.

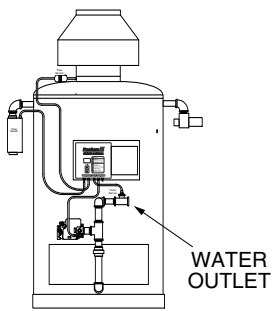

Figure 4.9.1

If the water outlet of the heater is to be connected to rigid piping that is to be distributed through a facility, it is recommended that a short “snubber” hose be used to connect the water outlet of the heater to the rigid piping. The “snubber” hose must be rated for the operating pressure of the pump and the water outlet temperature of the heater.

The plumbing from the water outlet should be properly sized for the flow rate desired in order to prevent pressure loss. As with inlet plumbing, teflon tape should be used to seal all joints.

4.10 ELECTRICAL CONNECTIONS

The heater is supplied with an electrical connection box where all electrical connections are to be made.

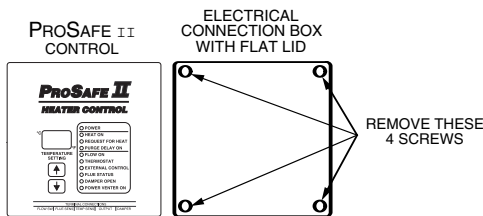

Figure 4.10.1

Remove the 4 screws holding the flat lid cover to the front of the electrical connection box as shown in figure 4.10.1 The inside of the electrical connection box has been divided into 2 sides. The right hand side is for the 120 volt connection to a transformer (if required), while the left hand side is for all low voltage connections.

There are two typical wiring configurations for the HWG40 heater. The first configuration is utilized when the heater is installed in conjunction with a Magikist control panel such as the CPTX timed shutdown control panel. For this configuration, all connections including power for the heater are made between the heater and the control panel. (the only exception to this is the optional power venter). Please refer to the wiring diagram supplied with the Magikist control panel for the most up to date instructions on wiring the heater to the control panel. For connections to the power venter, refer to the power venter wiring instructions later on in this section.

The second wiring configuration is used when installing the heater without a Magikist control panel. If 24VAC is not available you will need to mount the supplied transformer to the electrical connection box and wire the heater according to method 1 in figure 4.10.2. If the heater is being added to a system where an existing transformer has available 24VAC at a minimum of 40VA, you may wish to simply tap off this transformer and wire the heater according to method 2.

METHOD 1

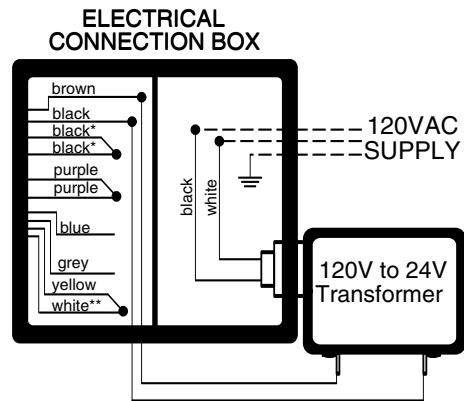

METHOD 2

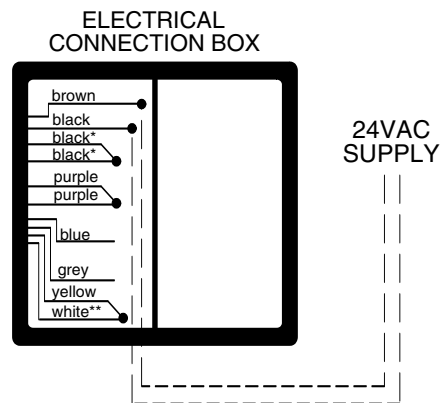

Field wiring shown in dashed lines.
 * Duplicate black wires for convenience.
 ** On some heaters this wire may be brown.

Figure 4.10.2

Even though in most cases it is not recommended that the 24vac supply be earth grounded, if the 24vac supply is to earth grounded then the earth ground MUST be connected to the black wire.

The EXTERNAL CONTROL connections (purple wires) provide an external means of enabling or disabling the heater. The EXTERNAL CONTROL connections are wired together at the factory, thereby always enabling the heater. For installations that utilize a Magikist control panel, follow the wiring diagram supplied with the control panel for the EXTERNAL CONTROL connections. For installations that do not utilize a Magikist

control panel, the EXTERNAL CONTROL connections may be left as is or they may be wired to an external switch, relay, or contactor. The switch will then act as an overriding master enable/disable for the heater. For example, the external switch may be used to provide a cold water rinse. Likewise, a keyswitch could be used to prevent unauthorized use. Alternately, if connected to the auxiliary contact of the motor contactor for the high pressure pump, the heater will be disabled whenever the pump is shut down. The switching device must be a single pole switch with a minimum rating of 100mA at 24 VAC. **These wires can only be switched, external power must NEVER be applied to the EXTERNAL-CONTROL purple wires.**

If your heater was provided with a flow switch, it is already connected to the *PROSAFE II* control. If the heater was not supplied with a flow switch, the flow switch installed in section 4.7 must be connected to the flow switch terminal connection located at the bottom of the *PROSAFE II* control (see figure 4.10.3). **External power must NEVER be applied to the flow switch terminal connections.**

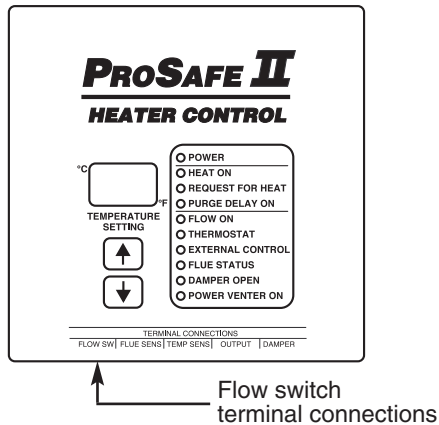

Figure 4.10.3

The EXT-FLOW connection (blue wire) provides an external signal as to whether the flow switch is opened or closed. For installations that utilize a Magikist control panel, follow the wiring diagram supplied with the control panel for the EXT-FLOW connection (blue wire). For installations that do not utilize a Magikist control panel and another component of your system requires the flow switch for some control aspect, the black wire and the EXT-FLOW blue wire may be used to drive a relay whose operation will then follow that of the flow switch. When the blue and black wires are connected to the 24 VAC coil of the relay (as shown in figure 4.10.4), the contacts of the relay will follow the opening and closing of the flow switch. **Never connect the blue and black wires together.**

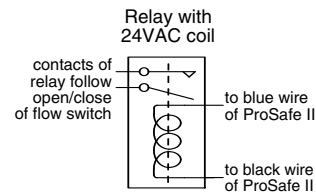

Figure 4.10.4

If a Magikist automatic vent damper is installed, locate the damper terminal connection located at the bottom of the *PROSAFE II* control (see figure 4.10.5). Remove the jumper plug and connect the damper cord to the damper terminal connection (see section 10.6 TERMINAL CONNECTIONS TO PROSAFE II for important information on connecting and disconnecting electrical connectors to the *PROSAFE II* control). **This procedure must be followed if an automatic vent damper is installed, otherwise the damper will not be controlled properly and a potentially dangerous situation may arise.** If an automatic vent damper is not installed, the jumper plug must remain installed on the damper terminal connection.

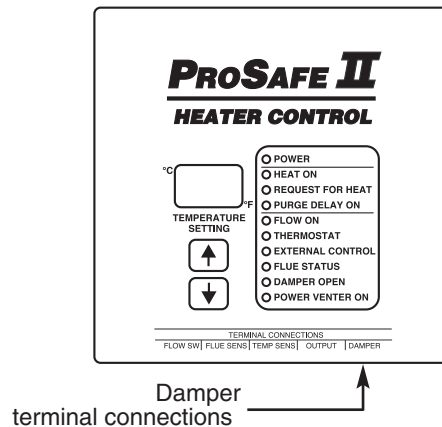

Figure 4.10.5

If a Magikist power venter is installed, the power venter must be wired to the *PROSAFE II* control according to the separate document HWG-PV Power Venter Wiring Instructions.

5.0 PRE-OPERATION CHECKS

THE FOLLOWING PRE-OPERATION CHECKS MUST BE CARRIED OUT, PREFERABLY BY A LICENSED GAS FITTER, AFTER INSTALLATION OF THE HEATER AND BEFORE OPERATION.

5.1 FLUSH DEBRIS FROM THE SYSTEM

During shipment and installation of your heater, debris may accumulate that should be removed before operating your heater. Following are steps that should be taken to remove any debris from the heater and the water inlet and outlet plumbing.

- 1) If your heater is part of a high pressure system, remove any spray nozzle(s) from the wash gun(s) attached to the water outlet of the heater. If your heater is part of a low pressure system direct the water output of the heater to a drain.
- 2) Run water through the heater for 5 to 10 minutes by either operating your high pressure pump or turning on the water supply to the water inlet of the heater.
- 3) Once complete the spray nozzle(s) may be reinstalled or the water output reconnected.

5.2 INITIAL POWER UP

With the gas supply still off, power-up the heater by energizing the power source to the heater. The power-up state of the *PROSAFE II* control is indicated by the buzzer sounding and the temperature setting displaying 888. Following power-up, the POWER and FLUE STATUS indicators on the *PROSAFE II* control should be on. The status of the other indicators depends on the current state of various inputs to the control. Refer to section 6.0 PROSAFE II CONTROL for a detailed explanation of the indicator lights of the *PROSAFE II* control.

5.3 CHECK FLOW SWITCH & AUTOMATIC VENT DAMPER

Before operating your heater, the flow switch and the automatic vent damper must be checked to ensure that they are operating correctly. If your heater does not have an automatic vent damper installed, the following sequence regarding the DAMPER-OPEN indicator will not apply as the DAMPER-OPEN indicator will always be on.

If the FLOW indicator does not follow the steps below, the flow switch may need adjustment. Refer to section 9.1 FLOW SWITCH for instructions on adjusting the flow switch. If the DAMPER-OPEN indicator does not follow the steps below, refer to section 11.0 TROUBLESHOOTING.

- 1) Turn on the high pressure pump or other

source supplying water to the heater such that water is flowing through the heater. The FLOW indicator on the *PROSAFE II* control should turn on. If an automatic vent damper is installed, the DAMPER-OPEN indicator will turn on approximately 15 to 20 seconds after the FLOW indicator has turned on.

- 2) Next, close the trigger gun or turn off the pump or other source supplying water to the heater such that there is no water flow through the heater. The FLOW indicator on the *PROSAFE II* control should turn off.
- 3) Repeat these steps 5 to 10 times to ensure that when there is water flow through the heater that the FLOW indicator is on, and when there is no water flow through the heater that the FLOW indicator is off.
- 4) Finally, turn off the pump or other source supplying water to the heater such that there is no water flow through the heater and the FLOW indicator turns off. If an automatic vent damper is installed the DAMPER-OPEN indicator will turn off after approximately a 5 minute period.

For the automatic vent damper to operate correctly, power to the heater must remain on. Removing power from the heater may result in the automatic vent damper being left in an open position before the *PROSAFE II* control has had the opportunity to close the damper. If your heater is equipped with an automatic vent damper, ensure that the DAMPER-OPEN indicator is off before powering down the heater.

5.4 BLEED OFF AIR

As with any new gas installation, the gas lines supplying the heater must be bled of air. **This must be carried out by qualified personnel only.** This step must be completed before proceeding to the next step.

5.5 LIGHTING THE PILOT BURNER (STANDING PILOT HEATERS ONLY)

CAUTION: Should pilot outage occur, wait 5 minutes before relighting to clear combustion chamber of accumulated gas. If an automatic vent damper is installed, you must also move the service switch on the motor housing of the vent damper to “HOLD DAMPER OPEN” position and wait 5 minutes before relighting (return switch to “AUTOMATIC OPERATION”

once relighting procedure is complete). Because LP (propane) gas is heavier than air, heaters utilizing these gases should have the floor areas vented and blown clear before relighting the pilot.

WARNING:

IF YOU SMELL GAS, SHUT OFF THE GAS SUPPLY TO THE APPLIANCE AND EXTINGUISH ANY OPEN FLAME. IF THE ODOUR PERSISTS, CALL YOUR GAS INSTALLER IMMEDIATELY.

ADVERTISSEMENT:

SI UNE ODEUR DE GAZ EST DÉCELÉE, COUPER L'ALIMENTATION EN GAZ DE L'APPAREIL ET ÉTEINDRE TOUTES LES FLAMMES. SI L'ODEUR PERSISTE, AVERTIR IMMÉDIATEMENT LE FOURNISSEUR DE GAZ.

To light the pilot, turn the knob on the combination gas valve from "off" to the "pilot" position. While pressing down on the knob, light the pilot. Once lit, hold down the knob (approximately 30 seconds) until pilot remains lit when the knob is released.

5.6 CHECK IGNITION OF MAIN BURNERS

- 1) Ensure that the POWER and FLUE STATUS indicators on the *PROSAFE II* control are both on. If a automatic vent damper is NOT installed the DAMPER OPEN indicator should be on. If a power venter is NOT installed the POWER VENTER ON indicator should be on. For installations that do NOT utilize a Magikist control panel and have wired the EXTERNAL CONTROL to an external switch, relay, or contactor, you will need to perform the action necessary to turn the EXTERNAL CONTROL indicator on.
- 2) If the THERMOSTAT indicator is not on, press the up arrow button located below the temperature setting display on the *PROSAFE II* control to increase the desired water outlet temperature, until the the THERMOSTAT indicator turns on.
- 3) FOR ELECTRONIC IGNITION HEATERS: Turn the switch on the combination gas valve from "off" to "on".
FOR STANDING PILOT HEATERS: Turn the knob on the combination gas valve from "pilot" to "on". On new installations, the pilot may be extinguished when moving the knob from "pilot" to "on" initially due to air inside the gas valve. If this occurs, repeat the steps in section 5.5.
- 4) If the water inlet of the heater is connected to a high pressure pump, start the pump and open the trigger gun to allow water flow through the heater. If the water source for the heater is not a pump, open the source of water so that water flows through the heater. In either case the

FLOW ON indicator will turn on once flow is started. If an automatic vent damper is installed, the the DAMPER-OPEN indicator will turn on approximately 15 to 20 seconds after the FLOW ON indicator is on. If a power venter is installed, the POWER VENTER ON indicator will turn on once air flow in the power venter is proven.

- 5) With FLOW ON, THERMOSTAT, EXTERNAL CONTROL, FLUE STATUS, DAMPER OPEN, and POWER VENTER ON indicators all on, the REQUEST FOR HEAT and HEAT ON indicators will turn on. The main burners should light within a few seconds. If the main burners do not light, see section 11.0 TROUBLESHOOTING
- 6) Close the wash gun or shut off the water supply to the heater. The FLOW ON indicator will turn off and the main burners should go off within 10 seconds.

For complete shutdown of the main burners, including the pilot, turn the switch or knob on the combination gas valve to "off" position.

WARNING:

RISK OF INJECTION OR SEVERE INJURY. KEEP CLEAR OF NOZZLE. DO NOT DIRECT DISCHARGE STREAM AT PERSONS. THIS EQUIPMENT IS TO BE USED ONLY BY TRAINED OPERATORS

ADVERTISSEMENT:

RISQUE D'INJECTION ET DE BLESSURES GRAVES. SE TENIR À L'ÉCART DU JET. NE PAS DIRIGER LE JET DE SORTIE VERS D'AUTRES PERSONNES. CONFIER L'UTILISATION DE CE MATÉRIEL À UN OPÉRATEUR QUALIFIÉ.

WARNING:

IF YOU SMELL GAS, SHUT OFF THE GAS SUPPLY TO THE APPLIANCE AND EXTINGUISH ANY OPEN FLAME. IF THE ODOUR PERSISTS, CALL YOUR GAS INSTALLER IMMEDIATELY.

ADVERTISSEMENT:

SI UNE ODEUR DE GAZ EST DÉCELÉE, COUPER L'ALIMENTATION EN GAZ DE L'APPAREIL ET ÉTEINDRE TOUTES LES FLAMMES. SI L'ODEUR PERSISTE, AVERTIR IMMÉDIATEMENT LE FOURNISSEUR DE GAZ.

6.0 PROSAFE II CONTROL

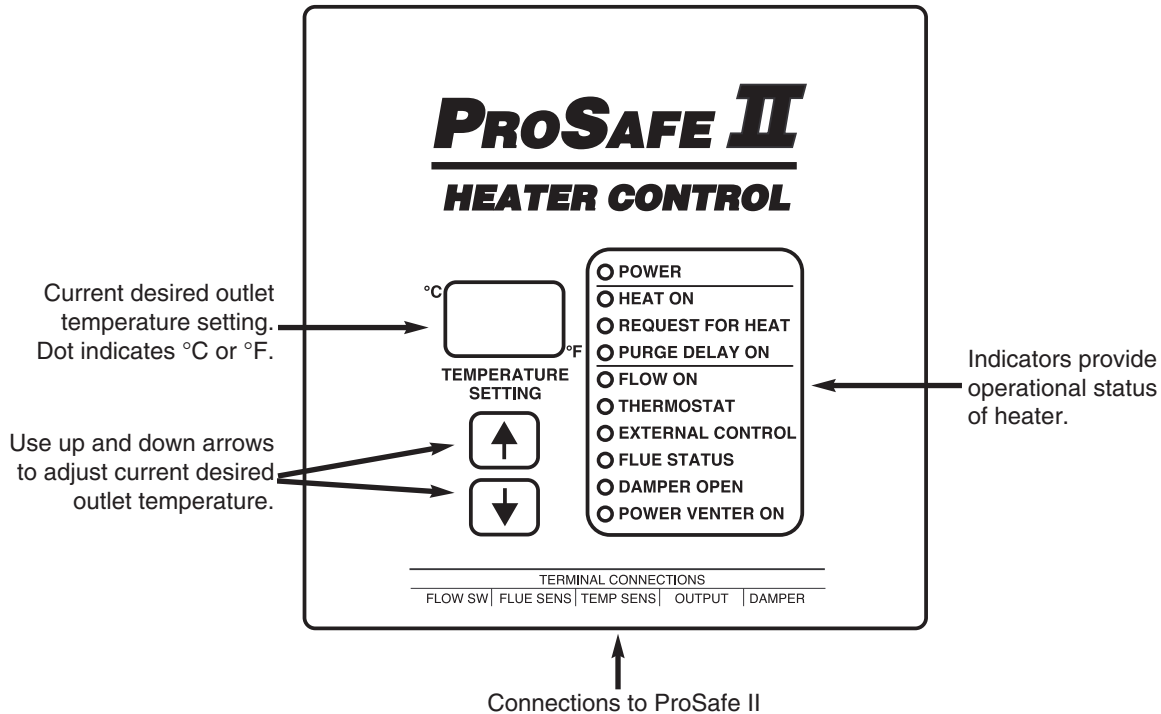

The HWG20 and HWG40 heaters are designed to provide hot water on demand at a given temperature setting. These heaters will automatically regulate the temperature of the outlet water to that which you desire by cycling on and off as required. Because these heaters are not storage type heaters, they must also cycle on and off dependent on whether or not there is water flow.

The operation of the heater is controlled and monitored by the *PROSAFE II* industrial heater control, an advanced microcontroller that monitors several aspects of the heater operation in order to provide safe and effective control of the heater. The *PROSAFE II* control provides visual status to the operator of the heater through it's front panel display on the heater. It also provides the setting for the outlet water temperature desired from the heater.

Should some condition arise which results in the heater exceeding its normal operating temperature, the *PROSAFE II* control provides overheat lockout protection, thus protecting the heater and operator from the dangers of a heater overheat condition. The *PROSAFE II* control also provides coil protection via a coil freeze warning should the temperature in the flue ever drop near the freezing point. Other conditions which affect the operation of the heater are detected and displayed to the operator by the *PROSAFE II* control.

Following is a description of the indicators and their function on the *PROSAFE II* control.

6.1 TEMPERATURE SETTING

The temperature setting display on the *PROSAFE II* control displays the current desired outlet water temperature from the heater. To change the temperature setting press the up or down arrow buttons located below the temperature setting display. Pressing and holding either of the up or down arrow buttons will result in the temperature setting changing slowly until a change of 5°, after which the setting will change rapidly until either button is released.

The temperature setting ranges from 40 to 200°F or 5 to 95°C depending on the temperature scale chosen. The current temperature scale is indicated by a red dot next to either the °C or the °F by the temperature setting display.

The temperature setting display is also used to indicate any error condition detected by the *PROSAFE II* control. When an error condition exists the current desired outlet water temperature is replaced by a flashing error code(s). Refer to the section 7.0 *PROSAFE II* ERRORS & WARNINGS for diagnosing error conditions.

6.2 POWER INDICATOR

The power-up state to the heater and the *PROSAFE II* control is indicated by the buzzer sounding and the temperature setting displaying 888 for 1 second. Following power-up, the POWER indicator on the *PROSAFE II* control should remain on.

6.3 HEAT ON INDICATOR

For electronic ignition (HSI) heaters the HEAT ON indicator on the *PROSAFE II* control indicates that the SmartValve gas valve has provided positive feedback that the intermittent pilot is lit and the main section of the gas valve is open.

For standing pilot heaters the HEAT ON indicator simply follows the on and off action of the REQUEST FOR HEAT indicator.

6.4 REQUEST FOR HEAT INDICATOR

The REQUEST FOR HEAT indicator on the *PROSAFE II* control indicates whether all conditions have been met to request that heat be turned on. The conditions required to request for heat are flow on, thermostat call for heat, external control on, flue status good, damper is open, power venter is on, and purge delay is off. Essentially if the six indicators FLOW ON, THERMOSTAT, EXTERNAL CONTROL, FLUE STATUS, DAMPER OPEN, and POWER VENTER ON are all on, and PURGE DELAY ON indicator is off, then REQUEST FOR HEAT will turn on. Should any of the six indicators turn off, then REQUEST FOR HEAT will turn off as well.

6.5 PURGE DELAY ON INDICATOR

The PURGE DELAY ON indicator on the *PROSAFE II* control indicates that the heater is currently in a purge delay. The purge delay is intended to provide a delay to eliminate rapid on/off cycling of the gas valve.

The purge delay occurs when there is an end to the current request for heat and the REQUEST FOR HEAT indicator turns off. At this point the PURGE DELAY ON indicator turns on and remains on for a period of six seconds. During this period if all conditions required to request for heat are met, the REQUEST FOR HEAT indicator will not turn on. If the conditions required to request for heat remain, the REQUEST FOR HEAT indicator will turn on once the purge delay is over and the PURGE DELAY ON indicator turns off.

6.6 FLOW ON INDICATOR

The FLOW ON indicator on the *PROSAFE II* control indicates whether there is water flow through the heater or not. If the indicator is on then there is water flow through heater. If the indicator is off then there is no flow of water through the heater.

If the FLOW ON indicator is flashing slow, the *PROSAFE II* control is indicating a warning that there is water flow through the heater and that it has been continuous for at least 10 minutes. This warning is strictly for information purposes as it may indicate a problem with the flow switch, since the wash gun in high pressure washing applications is typically not held open continuously for 10 minutes.

If the wash gun is held open continuously for more than 10 minutes in your operation, or your heater is being used in a different application where water flows through the heater continuously for more than 10 minute periods, then simply disregard the flashing FLOW ON indicator. If, however, the FLOW ON indicator is flashing and you have **not** had the wash gun open continuously for more than 10 minutes, the flow switch may not be operating correctly. **You should immediately turn off the gas flow to the main burners by manually turning the knob on the gas valve from ON to pilot (standing pilot heaters) or from ON to OFF (for electronic ignition heaters). This is important as the main burners of the heater may be continuing to fire with no water flow through the heater.** Following this, the operation of the flow switch must be checked. The FLOW ON indicator should be on when there is water flow through the heater and off when there is no water flow through the heater. If the FLOW ON indicator remains on or continues to flash even after flow through the heater has stopped, see section 9.1 FLOW SWITCH for servicing the flow switch.

6.7 THERMOSTAT INDICATOR

The THERMOSTAT indicator on the *PROSAFE II* control indicates whether the temperature of the outlet water of the heater is below, at, or greater than the current temperature setting on the temperature setting display. If the THERMOSTAT indicator is on, then the outlet water temperature of the heater is below the current temperature setting. If the THERMOSTAT indicator is off, then the outlet water temperature of the heater is at or above the current temperature setting.

If the THERMOSTAT indicator is flashing fast and the temperature setting display is flashing an error code, the *PROSAFE II* control is indicating that an error condition exists. Refer to section 7.0 *PROSAFE II* ERRORS & WARNINGS for diagnosing error conditions.

6.8 EXTERNAL CONTROL INDICATOR

The action displayed by the EXTERNAL CONTROL indicator is dependent on how this option was setup with your heater. The EXTERNAL CONTROL is intended to show whether an external control has enabled or disabled the heater from operating.

For installations that utilize a Magikist control panel, the EXTERNAL CONTROL indicator should be on only when the pump is running.

For installations that do not utilize a Magikist control panel, the EXTERNAL CONTROL, as supplied from the factory, will always be on. If the installer has chosen to use the EXTERNAL CONTROL with an external switch, relay, or contactor, the EXTERNAL CONTROL indicator will follow the opening and closing action of that device.

6.9 FLUE STATUS INDICATOR

The FLUE STATUS indicator provides status as to one of the key safety components of your heater, the flue sensor. For normal operation of the heater the FLUE STATUS indicator remains on.

If the FLUE STATUS indicator is flashing fast and the temperature setting display is flashing an error code, the *PROSAFE II* control is indicating that an error condition exists. Refer to section 7.0 *PROSAFE II* ERRORS & WARNINGS for diagnosing error conditions.

If the FLUE STATUS indicator is flashing slow, the *PROSAFE II* control is indicating that a warning condition exists. Refer to section 7.0 *PROSAFE II* ERRORS & WARNINGS for diagnosing error conditions.

6.10 DAMPER OPEN INDICATOR

The *PROSAFE II* control provides the necessary control to operate the Magikist damper effectively and safely. The *PROSAFE II* control will open your damper whenever there is water flow through the heater. In addition the *PROSAFE II* control will close the damper only after there is no water flow for a preset period of time. This eliminates the

on/off cycling a damper experiences in high pressure wash systems where wash guns are opened and closed frequently.

If your heater is not equipped with an automatic vent damper, the DAMPER OPEN indicator will be on whenever there is power to the heater.

If your heater is equipped with a Magikist automatic vent damper, the DAMPER OPEN indicator is on when the damper is in the open position and off when the damper is closed or in the process of opening or closing. Because of the time required to open and close the damper, there will be a delay of approximately 15 to 20 seconds from the time the FLOW ON indicator turns on (indicating water flow through the heater) and the DAMPER OPEN indicator turns on.

6.11 POWER VENTER ON INDICATOR

The *PROSAFE II* control provides the necessary control to operate the Magikist power venter effectively and safely. The *PROSAFE II* control will turn on your power venter whenever there is water flow through the heater. In addition the *PROSAFE II* control will shut off the power venter only after there is no water flow for a preset period of time. This eliminates the on/off cycling a power venter experiences in high pressure wash systems where wash guns are opened and closed frequently.

If your heater is not equipped with a power venter, the POWER VENTER ON indicator will be on whenever there is power to the heater.

If your heater is equipped with a Magikist power venter, the POWER VENTER ON indicator is on only when air flow in the power venter is proven.

7.0 PROSAFE II ERRORS & WARNINGS

7.1 ERROR CONDITIONS

The PROSAFE II control indicates error conditions via the indicator lights and the temperature setting display. Error conditions require immediate attention in order to ensure continued operation of the heater. Whenever an error condition is present, the heater will not fire. Some error conditions lockout the operation of the heater until the error is cleared by a power down/up sequence. The alarm buzzer sounds on all errors.

Should an error condition arise, the indicator light that relates to the error condition will flash on and off at a fast rate. In addition, the temperature setting display will no longer show the desired outlet water temperature, but instead will display a flashing error code Exx where xx is the error code.

Please see section 11.0 TROUBLESHOOTING for diagnosing error conditions.

7.2 WARNING CONDITIONS

The PROSAFE II control indicates warning conditions via the indicator lights. Unlike error conditions, warning conditions do not prevent the heater from firing. Warning conditions should be attended to promptly in order to ensure the continued safe operation of the heater.

Should a warning condition arise, the indicator light that relates to the warning condition will flash on and off at a slow rate.

Please see section 11.0 TROUBLESHOOTING for diagnosing warning conditions.

Table 7.1 - ERROR CONDITIONS

Temperature Setting Display Flashes	Indicator Light Flashing Fast	Description	Requires Power Down/Up Sequence to Clear
E10	FLUE STATUS	Problem with communication to flue sensor (open).	No
E11	FLUE STATUS	Problem with communication to flue sensor (short).	No
E15	FLUE STATUS	Flue overheat condition.	Yes
E20	THERMOSTAT	Problem with communication to temperature sensor (short).	No
E21	THERMOSTAT	Problem with communication to temperature sensor (short).	No
E30	REQUEST FOR HEAT	Problem with OUTPUT driver (open).	Yes
E31	REQUEST FOR HEAT	Problem with OUTPUT driver (short).	Yes
E59	(none)	Problem with internal memory.	Yes

Table 7.2- WARNING CONDITIONS

Indicator Light Flashing Slow	Description
FLUE STATUS	Temperature in flue is near or below freezing. Water in heater coil is in danger of freezing and damaging coil.
FLOW ON	Flow has been asserted for more than 10 minutes.

8.0 ELECTRONIC IGNITION OPERATION

This section is applicable only to heaters which utilize electronic ignition (HSI).

When there is a request for heat as shown by the REQUEST FOR HEAT indicator on the *PROSAFE II* control, the *PROSAFE II* control signals the SmartValve gas valve (hereafter referred to as the SmartValve) to start the ignition sequence. In response the SmartValve will begin the pilot trial period, where the SmartValve attempts to light the pilot for a period of 90 seconds. This 90 second period consists of the following sequence: hot surface ignitor (HSI) on for 30 seconds; HSI off for 30 seconds; HSI on for an additional 30 seconds. If the attempt to light the pilot is successful during the pilot trial period, the main section of the SmartValve will then energize for main burner ignition to occur. If the attempt to light the pilot is unsuccessful after 90 seconds, the SmartValve will begin a 5 minute delay period before reattempting another pilot trial period. The SmartValve is a continuous retry control. Thus it will continuously repeat the pilot trial period followed by the 5 minute

delay period, until the pilot is successfully lit or the *PROSAFE II* control no longer indicates REQUEST FOR HEAT.

If after successful lighting of the pilot, the SmartValve detects that the pilot is no longer lit, it will once again begin the pilot trial period. If the pilot is not relit after 90 seconds, the SmartValve will begin the 5 minute delay period. Continuous retry will occur as described above.

The HEAT ON indicator of the ProSafe II control indicates that the SmartValve gas valve has provided positive feedback that the pilot is lit and the main section of the gas valve is open. If the REQUEST FOR HEAT indicator of the *PROSAFE II* is lit but the HEAT ON indicator of the the *PROSAFE II* is not lit, there is no indication of what state the SmartValve is in with regards to it's continuous retry sequence. In other words the SmartValve could be in the pilot trial period (HSI on or HSI off), or the 5 minute delay period.

9.0 MAINTENANCE

9.1 FLOW SWITCH (MODEL HPFS38)

On heaters where the mineral content of the water is high or where chemicals or soaps are used, it may be necessary on occasion to disassemble the housing and clean any debris and build up inside the flow switch. This maintenance will allow the magnet to continue to move smoothly and freely, and will eliminate nuisance failures due to scale buildup. It is suggested that the flow switch be inspected and cleaned as necessary each time the heater (or possibly the high pressure pump) receives routine maintenance or service.

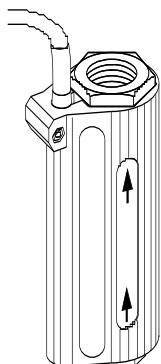

Figure 9.1.1

To adjust the flow switch, the reed switch will need to be repositioned. The reed switch is housed inside the cylindrical metal can from which the jacketed wire comes out. To reposition the reed switch loosen the friction bolt/nut and slide the cylindrical metal can in or out such that the FLOW indicator is on when there is flow and off when there is no flow through the switch. Retighten the friction bolt/nut to secure the position of the reed switch.

9.2 RELIGHTING THE PILOT BURNER (STANDING PILOT HEATERS ONLY)

CAUTION: Should pilot outage occur, wait 5 minutes before relighting to clear combustion chamber of accumulated gas. If an automatic vent damper is installed, you must also move the service switch on the motor housing of the vent damper to "HOLD DAMPER OPEN" position and wait 5 minutes before relighting (return switch to "AUTOMATIC OPERATION" once relighting procedure is complete). Because LP (propane) gas is heavier than air, heaters utilizing these gases should have the floor areas vented and blown clear before relighting the pilot.

WARNING:

IF YOU SMELL GAS, SHUT OFF THE GAS SUPPLY TO THE APPLIANCE AND EXTINGUISH ANY OPEN FLAME. IF THE ODOUR PERSISTS, CALL YOUR GAS INSTALLER IMMEDIATELY.

ADVERTISSEMENT:

SI UNE ODEUR DE GAZ EST DÉCELÉE, COUPER L'ALIMENTATION EN GAZ DE L'APPAREIL ET ÉTEINDRE TOUTES LES FLAMMES. SI L'ODEUR PERSISTE, AVERTIR IMMÉDIATEMENT LE FOURNISSEUR DE GAZ.

Should pilot outage occur, refer to section 5.5 LIGHTING THE PILOT BURNER for instructions on relighting the pilot burner.

9.3 CARE OF MAIN BURNERS

Due to condensation from heater coils dripping on the burners, a scale build-up may occur in the burner jet orifices.

To remove the burner bar from the heater, turn off the gas to the heater by turning the knob on the gas valve to the "off" position. For standing pilot heaters, disconnect the pilot tube and thermocouple at the gas valve. For electronic ignition heaters, disconnect the pilot tube and the electrical connections between the pilot assembly and the electronic ignition module (take care to note the connections so that they may be reconnected correctly). Disconnect the union joining the burner bar to the modulating gas valve, and the U-bolt retaining the feed pipe at the bottom of the heater inside the door. Slide the burner bar out through the shell opening.

To clean burner jets select the proper size drill for type of gas involved. Use a pin vise to hold the drill and ream out each jet orifice by hand. It is recommended that the burner jets not be removed from the burner bar except for jets that require replacing. **Do not ream out orifices to a larger size than shown.**

HWG40:

- #55 drill for natural gas 0-2000ft. (0-610 m)
- #56 drill for natural gas 2000-4000ft. (610-1370 m)
- #68 drill for LP gas 0-2000ft. (0-610 m)
- #70 drill for LP gas 2000-4000ft. (610-1370 m)

HWG20

- #52 drill for natural gas 0-2000ft. (0-610 m)
- #53 drill for natural gas 2000-4000ft. (610-1370 m)
- #63 drill for LP gas 0-2000ft. (0-610 m)
- #64 drill for LP gas 2000-4000ft. (610-1370 m)

9.4 CLEANING HEATER COIL OF SCALE

Excessive scale in heater coils can reduce the recovery rate of the heater and restrict the flow of water through the heater. Use of hard water through the heater tends to accelerate scale build-up. Should heater coils develop excessive scale build-up it may be necessary to use a coil cleaner to remove the scale build-up. Use only an approved coil cleaner specially designed for cleaning scale and mineral deposits from steel coils, such as Magikist *MAGIKCOIL* de-liming acid.

To clean the heater coil of scale build-up, follow the directions provided with the coil cleaner. Never allow the coil cleaner to sit in the coil overnight or for long periods of time. Always flush out the coil thoroughly with water after cleaning.

10.0 HELPFUL INFORMATION

10.1 COIL CONDENSATION

During the operation of your heater, you may notice water in the base of the heater or you may hear the sizzling of water drops falling on the flames of the main burner. This collection of water or “dripping” of water is typical in the operation of all steel coil heaters. It is caused by the products of gas combustion which produce gaseous carbon dioxide and water vapour. The water vapour condenses on the coils which have cold water running through them. The lower the temperature of the incoming water, and the higher the rate of combustion and/or the higher the relative humidity, the more “drip” that occurs. Over a period of time this tends to decrease.

If you suspect that the water in the base of the heater is not from coil condensation, turn the heater off such that the main burners are not lit and run water through the heater. The “dripping” of water from coil condensation will stop after a short period of time.

10.2 COIL SCALING

Scale build-up in the heater coil can reach a point where the recovery rate of the heater is reduced and/or the flow of water through the heater is restricted. Use of hard water through the heater tends to accelerate scale build-up. Should scale build-up reach a point where the operation of the heater is affected, descaling with an approved coil cleaner may be required. See section 8.4 CLEANING HEATER COIL OF SCALE for more information.

10.3 FREEZING CONDITIONS

Freezing conditions can result in severe damage to the heater coil. Coils must be drained completely with compressed air or have anti-freeze run through them if they are exposed to freezing weather. Note that heater coils installed in a heated building can still freeze. If the building has a negative pressure cold air will be drawn down the chimney and could freeze the top of the coil. This can normally be prevented by the use of an automatic vent damper.

10.4 USE OF ACIDS

If acids of any type are used then a form of downstream chemical injection or suitable check valve should be used to protect the coil.

10.5 COIL TEST

After manufacture each coil is hydrostatically pressure tested to 3500 PSI. Each heater also has a final hydrodynamic leak test performed after final assembly (with all fittings installed) before the heater leaves the factory.

10.6 TERMINAL CONNECTIONS TO *PROSAFE II*

Except for the FLOW SW connection, the *PROSAFE II* uses lockable polarized plugs for all its terminal connections. To remove a plug you must press down on the locking pin and then pull the plug out. Never use excessive force to remove the plugs. When reinserting a plug, simply align the plug with the correct terminal connection and insert. Plugs are polarized and will only fit into the correct terminal connection.

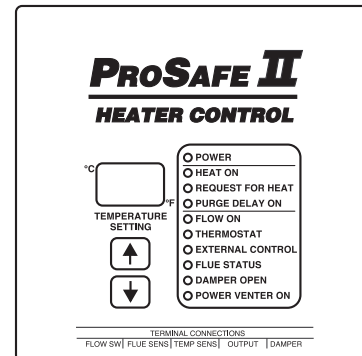

↑
Connections to ProSafe II

11.0 TROUBLESHOOTING

Symptom	Probable Cause	Corrective Action
•Heater does not power-up (POWER indicator on PROSAFE II control does not turn on).	<ul style="list-style-type: none"> •Power to heater not turned on. •24 VAC power not connected to brown & black wires. 	<ul style="list-style-type: none"> •Turn on power supply to the heater. •See section 4.10 ELECTRICAL CONNECTIONS.
•Main burner does not light.	<ul style="list-style-type: none"> •Gas supply turned off. •Gas valve not in “on” position. •Pilot burner is not lit or has been extinguished (standing pilot models only). •REQUEST FOR HEAT indicator on PROSAFE II control is not on. 	<ul style="list-style-type: none"> •Turn on gas supply to heater. •Turn knob on gas valve to “on” position. •Relight pilot burner. See section 5.5 LIGHTING THE PILOT BURNER. •See section 6.0 PROSAFE II CONTROL.
•Main burner does not shut off.	<ul style="list-style-type: none"> •Flow switch misadjusted. •Incoming gas pressure is too high 	<ul style="list-style-type: none"> •See section 5.3 CHECK FLOW SWITCH & AUTOMATIC VENT DAMPER for instructions on checking the operation of the flow switch. See section 9.1 FLOW SWITCH for instructions on adjusting the flow switch. •Have gas service personnel check and adjust supply gas pressure.
•Pilot goes out frequently (standing pilot heaters only).	<ul style="list-style-type: none"> •Heater is in location that is too drafty. •Pilot assembly requires service. 	<ul style="list-style-type: none"> •Relocate heater. See section 4.1 LOCATION. •Have gas service personnel check operation of pilot assembly and thermocouple.
•Pilot cannot be lit (standing pilot heaters only).	<ul style="list-style-type: none"> •Pilot assembly requires service. 	<ul style="list-style-type: none"> •Have gas service personnel check operation of pilot assembly and thermocouple.
•Water collecting in the base of heater.	<ul style="list-style-type: none"> •A fair amount of condensation which can collect in the base of the heater is a normal product of the operation of your heater. 	<ul style="list-style-type: none"> •No action is required. For more information refer to section 10.1 COIL CONDENSATION.
•FLOW ON indicator is on when there is no water flow.	<ul style="list-style-type: none"> •Flow switch misadjusted. 	<ul style="list-style-type: none"> •See section 5.3 CHECK FLOW SWITCH & AUTOMATIC VENT DAMPER for instructions on checking the operation of the flow switch. See section 9.1 FLOW SWITCH for instructions on adjusting the flow switch.
•FLOW ON indicator is off when there is water flow.	<ul style="list-style-type: none"> •Flow switch misadjusted or inoperative. 	
•FLOW ON indicator flashes.	<ul style="list-style-type: none"> •Warning condition that consistent water flow through the heater has been detected. 	<ul style="list-style-type: none"> •This indication is only informative and may not indicate a problem. Refer to section 6.6 FLOW ON INDICATOR for more information.

Symptom	Probable Cause	Corrective Action
<ul style="list-style-type: none"> EXTERNAL CONTROL indicator is always off. 	<ul style="list-style-type: none"> If the installer of your heater has utilized an external master enable/disable for the heater (i.e. a keyswitch to prevent unauthorized use), then that master enable/disable is not enabled (i.e. the switch is not turned on). EXTERNAL CONTROL connections are not wired correctly. 	<ul style="list-style-type: none"> Enable the external master enable/disable. See section 4.10 ELECTRICAL CONNECTIONS for proper wiring of the EXTERNAL CONTROL connections.
<ul style="list-style-type: none"> EXTERNAL CONTROL indicator is always on. 	<ul style="list-style-type: none"> The heater is supplied with the EXTERNAL CONTROL option bypassed such that the EXTERNAL CONTROL indicator will always be on. If your installer has not utilized an external master enable/disable for the heater, then it is correct for the EXTERNAL CONTROL indicator to be on all the time. 	<ul style="list-style-type: none"> No action required.
<ul style="list-style-type: none"> FLUE STATUS indicator is flashing but temperature setting shows no error and heater operates correctly. 	<ul style="list-style-type: none"> Warning condition that temperatures in flue are at or near freezing. 	<ul style="list-style-type: none"> Take necessary steps to increase temperature in flue so that coil does not freeze.
<ul style="list-style-type: none"> DAMPER-OPEN indicator is always on. 	<ul style="list-style-type: none"> If an automatic vent damper is <u>not</u> installed, then this is normal and correct operation. The automatic vent damper may not have been correctly connected, or may be jammed due to improper installation. The service switch on the motor housing of the damper is in "HOLD DAMPER OPEN" position. 	<ul style="list-style-type: none"> No action required. See section 4.10 ELECTRICAL CONNECTIONS for proper wiring of an automatic vent damper. Section 5.3 CHECK FLOW SWITCH & AUTOMATIC VENT DAMPER provides instructions to ensure the damper is operating correctly. Move service switch to the "AUTOMATIC OPERATION" position.
<ul style="list-style-type: none"> DAMPER-OPEN indicator is always off. 	<ul style="list-style-type: none"> If an automatic vent damper is <u>not</u> installed then the jumper plug required may not be installed. The automatic vent damper may not have been correctly connected, or may be jammed due to improper installation. 	<ul style="list-style-type: none"> See section 4.10 ELECTRICAL CONNECTIONS for proper wiring of the heater with and without an automatic vent damper. Section 5.3 CHECK FLOW SWITCH & AUTOMATIC VENT DAMPER provides instructions to ensure the damper is operating correctly.

Symptom	Probable Cause	Corrective Action
•Temperature setting display flashes E10 and FLUE STATUS indicator is flashing.	•Communicaton problem with flue sensor (open).	•Check connection of flue sensor to PROSAFE II. Replace flue sensor if necessary.
•Temperature setting display flashes E11 and FLUE STATUS indicator is flashing.	•Communicaton problem with flue sensor (short).	•Check connection of flue sensor to PROSAFE II. Replace flue sensor if necessary.
•Temperature setting display flashes E15 and FLUE STATUS indicator is flashing.	•Overheat condition detected.	•Temperature in flue has exceeded maximum limit. Most common condition is that main burner of heater is on with no water flow the heater. Investigate and correct immediately.
•Temperature setting display flashes E20 and THERMOSTAT indicator is flashing.	•Communicaton problem with temperature sensor (open).	•Check connection of temperature sensor to PROSAFE II. Replace temperature sensor if necessary.
•Temperature setting display flashes E21 and THERMOSTAT indicator is flashing.	•Communicaton problem with temperature sensor (short).	•Check connection of temperature sensor to PROSAFE II. Replace temperature sensor if necessary.
•Temperature setting display flashes E30 and REQUEST FOR HEAT indicator is flashing.	•Problem with output driver for gas valve (open). PROSAFE II is attempting to energize the gas valve but is not receiving the correct internal feedback that the gas valve is being energized.	•Contact qualified service personnel.
•Temperature setting display flashes E31 and REQUEST FOR HEAT indicator is flashing.	•Problem with output driver for gas valve (short). PROSAFE II is not attempting to energize the gas valve but is not receiving the correct internal feedback that the gas valve is not being energized.	•TURN KNOB ON GAS VAVLE TO OFF POSITION IMMEDIATELY. SHUT OFF GAS SUPPLY TO HEATER IMMEDIATELY. EXTINGUISH ANY OPEN FLAME IMMEDIATELY. Contact qualified service personnel.
•Temperature setting display flashes E59.	•Problem with internal memory of PROSAFE II.	•Contact qualified service personnel.

PART NO.	DESCRIPTION
HWG40-2	OUTER SHELL ASSEMBLY
HWG40-3	COIL ASSEMBLY
HWG40-4	TOP HEADER SEAL PLATE
HWG40-5	HEATER HEADER
HWG40-6	1/4" SELF TAPPING SCREWS
HWG40-7	NAME PLATE
HWG40-8	RIGHT HAND DOOR
HWG40-9	LEFT HAND DOOR
HWG40-10	3/16" SELF TAPPING SCREWS
HWG40-11	DOOR KNEES
HWG40-12	MAIN BURNER ASSEMBLY
HWG40-13	PILOT BURNER ASSEMBLY
HWG40-14	REFLECTOR PLATE
HWG40-15	INDUCTING VALVE
HWG40-16	GAS VALVE
HWG40-17	3/4" X 2 1/2" NIPPLE
HWG40-18	1" X 3/4" REDUCING ELBOW
HWG40-19	1" X 4" NIPPLE
HWG40-20	1" STREET ELBOW
HWG40-21	1" X 1" NIPPLE
HWG40-22	1" UNION
HWG40-23	1" X 5" NIPPLE
HWG40-24	1" X 3/4" REDUCING ELBOW
HWG40-25	3/4" X 9" NIPPLE
HWG40-26	3/4" ELBOW
HWG40-27-4H	THERMOPILE GENERATOR
HWG40-27-2BV	THERMOPILE-24VOLT NG
HWG40-28	PILOT GAS TUBE
HWG40-29	TEMPERATURE CONTROL
HWG40-30	1/2" X 3/8" 90 DEGREE BENDING
HWG40-31	1/2" CLAMP NIPPLE
HWG40-32	1" X 3/4" 1.1" REDUCING Tee
HWG40-33	1" X 1" NIPPLE
HWG40-34	3/4" X 5" NIPPLE
HWG40-35	1/2" X 3/8" REDUCING NIPPLE
HWG40-36	3/4" X 1/2" REDUCING ELBOW
HWG40-37	RELIEF VALVE
HWG40-38	3/4" X 1/2" REDUCING ELBOW
HWG40-39	NOTION PLATE
HWG40-40	INSULATION SUPPORT
HWG40-41	3/4" NIPPLE
HWG40-42	3/4" NIPPLE
HWG40-43	DRAFT HOOD

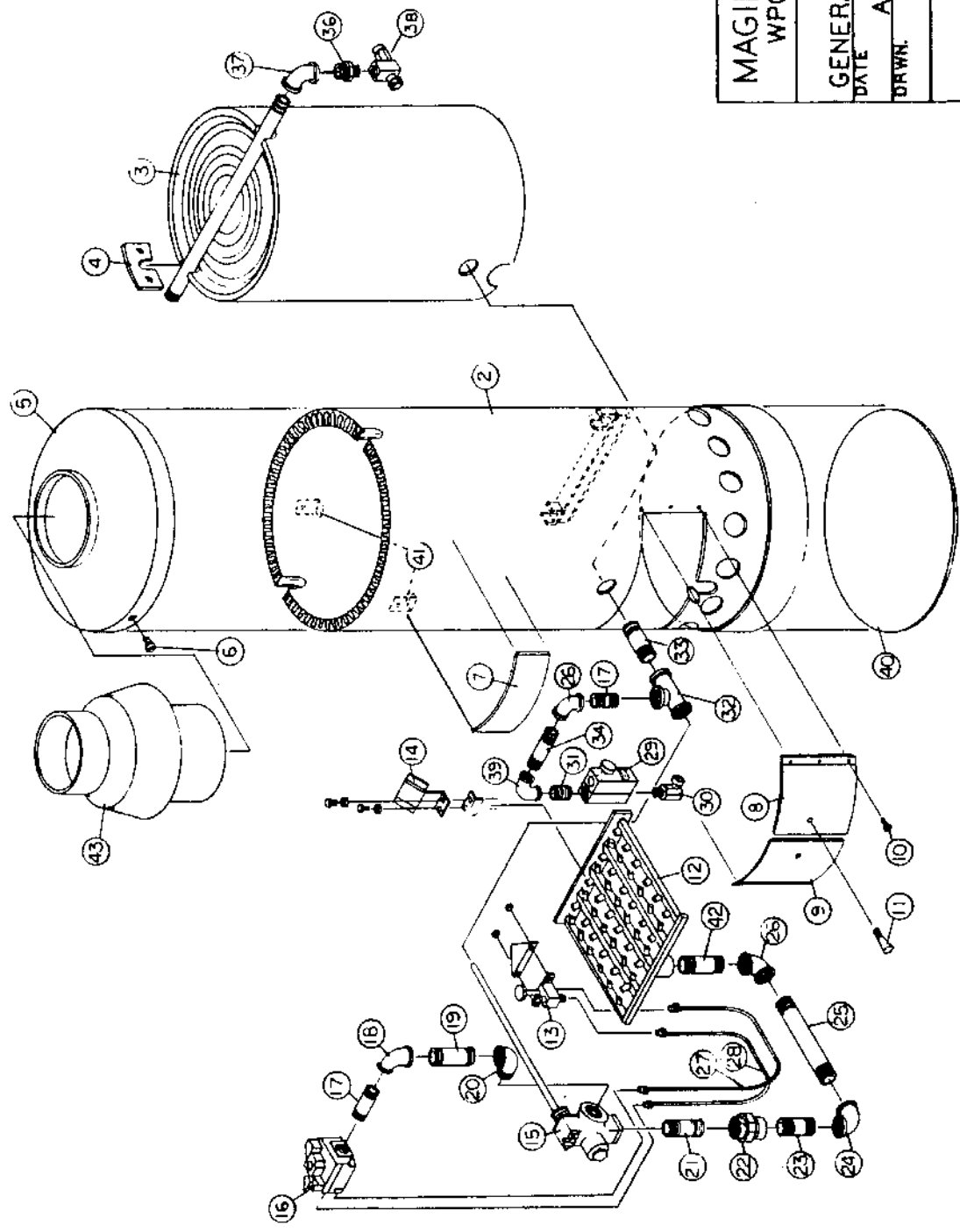

MAGIKIST WPG.	LTD. CAN.
HWG-40	
GENERAL ARRANGEMENT	
DATE	APR '88
DRWN.	E.H.
	HWG40-1

Part Number	Description
HWG20-2	outer shell assembly
HWG20-3	coil assembly
HWG20-4	top header seal plate
HWG20-5	header header
HWG20-6	1/4" x 1/2" x 3/4" tee
HWG20-7	same plate
HWG20-8	same plate
HWG20-10	3/16" seal tapping joints
HWG20-12	burner bar
HWG20-13	plati assembly
HWG20-14	collector plate
HWG20-16	gas valve
HWG20-17	3/4" close nipple
HWG20-18	3/4" x 1/2" x 3/4" tee
HWG20-20	3/4" close nipple
HWG20-21	1/2" close nipple
HWG20-22	1/2" x 3/16" nipple
HWG20-24	1/2" x 1/2" nipple
HWG20-25	1/2" x 1/2" nipple
HWG20-26	1/2" inlet elbow
HWG20-27M	thermogal generator
HWG20-2724	thermocouple - 24v
HWG20-28	plati gas tube
HWG20-29	temperature control
HWG20-30	1/2" x 3/8" 90° swivel
HWG20-31	3/4" x 2-1/2" nipple
HWG20-32	3/4" x 3/4" x 1/2" tee
HWG20-33	3/4" solid connector
HWG20-34	1/2" x 4-1/2" nipple
HWG20-35	1/2" x 3/8" reducing nipple
HWG20-37	3/4" x 1/2" reducing elbow
HWG20-38	relief valve
HWG20-40	ballfit
HWG20-41	insulation support
HWG20-43	draft hood
HWG20-52N	burner for natural gas
HWG20-52P	burner for LP

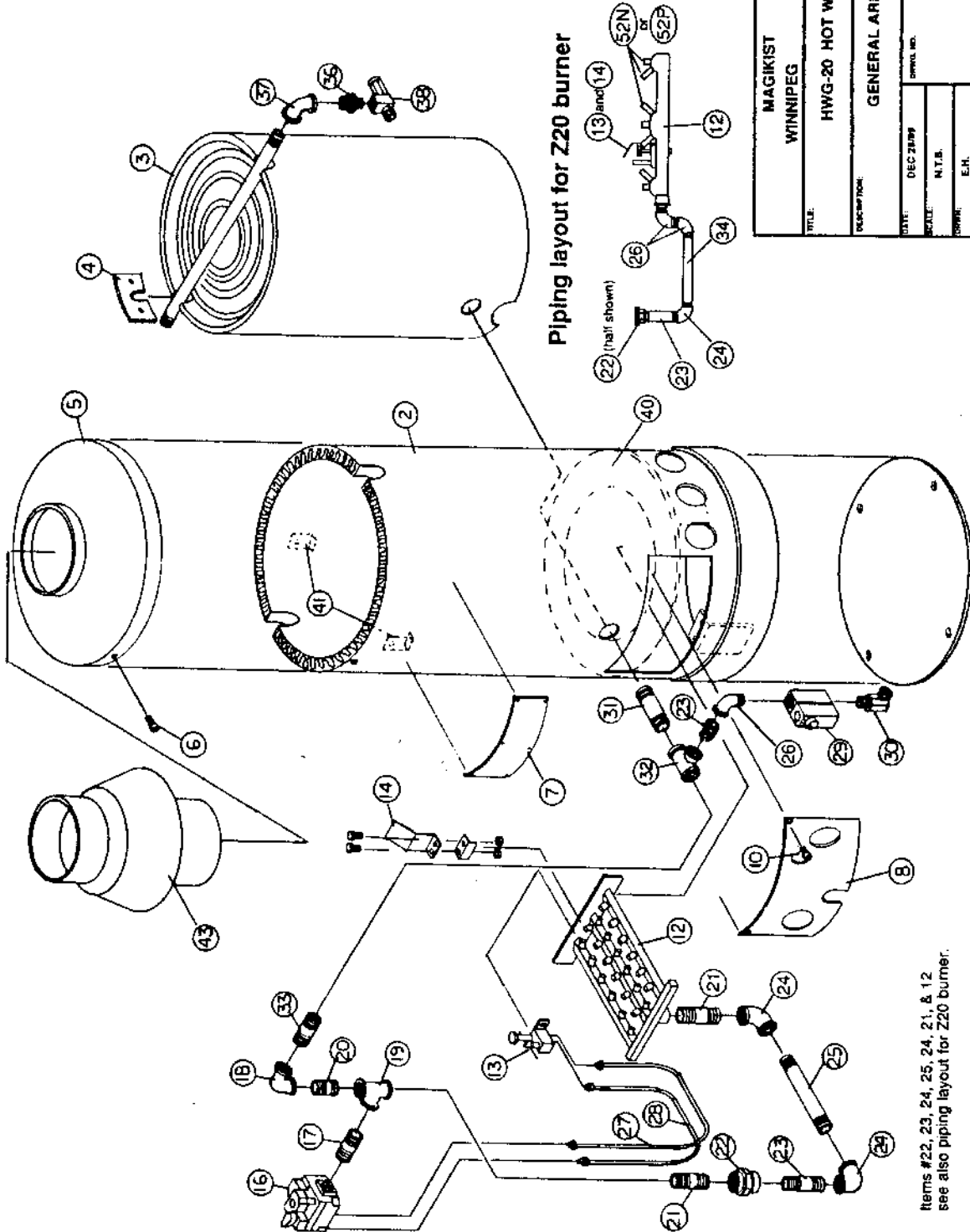

MAGIKIST LTD.	
WINNIPEG CANADA	
HWG-20 HOT WATER GENERATOR	
GENERAL ARRANGEMENT	
DATE: DEC 28/69	DRAWN BY: E.H.
SCALE: N.T.S.	ENGINEER: E.H.
HWG20-1	

Items #22, 23, 24, 25, 24, 21, & 12 see also piping layout for Z20 burner.

HWG20 & HWG40 Wiring 24 volt standing pilot systems

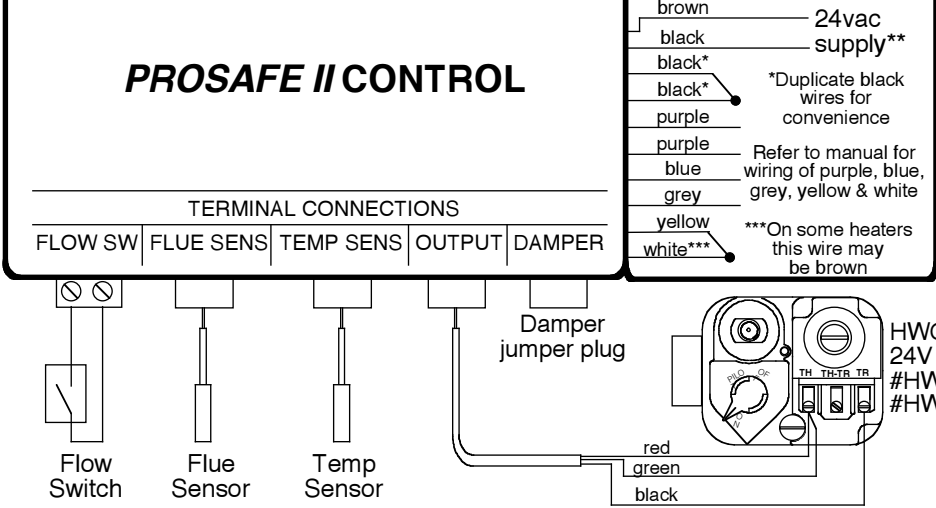

Electrical Connection Box

****IMPORTANT:** If the 24 vac supply is to be earth grounded, earth ground must be connected to the black wire.

Wiring-diagram.cad

12.0 SPECIFICATIONS

HWG40

Type	Instantaneous steel coil
Gas supply	Natural (-N models)/LP (-P models)
Coil specifications	3/4" I.P.S. steel pipe Sch 80
Maximum recovery capacity (100°F rise)	331.9 U.S. gallons per hour
Maximum operating pressure	3000 P.S.I.
Maximum operating temperature	200°F
Minimum water flow rate	1.0 U.S. gallons per minute
Flue outlet size	10" diameter
Normal input ratings	
0 - 2000 ft (0 - 610 m)	395,000 BTU/hour (maximum)
2000 - 4000 ft (610 - 1370 m)	355,500 BTU/hour (maximum)
Manifold gas pressure	
Natural gas	3.5" W.C.
LP (propane) gas	11.0" W.C.
Maximum supply gas pressure	
Natural gas	14" W.C.
LP (propane) gas	11.0" W.C.
Flooring type required	Non-combustible
Shell diameter	24"
Width	32"
Depth	32"
Height (without draft hood)	46"
Height (with draft hood)	66-3/4"
Shipping weight	418 lbs.

HWG20

Type	Instantaneous steel coil
Gas supply	Natural (-N models)/LP (-P models)
Coil specifications	3/4" I.P.S. steel pipe Sch 80
Maximum recovery capacity (100°F rise)	150 U.S. gallons per hour
Maximum operating pressure	3000 P.S.I.
Maximum operating temperature	200°F
Minimum water flow rate	1.0 U.S. gallons per minute
Flue outlet size	7" diameter
Normal input ratings	
0 - 2000 ft (0 - 610 m)	200,000 BTU/hour (maximum)
2000 - 4000 ft (610 - 1370 m)	180,000 BTU/hour (maximum)
Manifold gas pressure	
Natural gas	3.5" W.C.
LP (propane) gas	11.0" W.C.
Maximum supply gas pressure	
Natural gas	14" W.C.
LP (propane) gas	11.0" W.C.
Flooring type required	Non-combustible
Shell diameter	16"
Width	22"
Depth	23"
Height (without draft hood)	35"
Height (with draft hood)	50-1/2"
Shipping weight	200 lbs.

WARRANTY

Magikist heaters are warranted by the manufacturer to be free from defects in material and workmanship for one year from date of manufacturer's shipment, provided the equipment is installed and operated in accordance with factory recommendations and instructions. This warranty is limited to repairing or replacing products which manufacturer's investigation shows were defective at the time of shipment by the manufacturer. This warranty does not cover normal wear, nor does it cover damage caused by neglect, misuse, accident, faulty installation or tampering in a manner to impair its normal operation. All products subject to this warranty shall be returned **freight prepaid** to Magikist Ltd., Winnipeg, Canada for examination, repair, or replacement.

The express warranty set forth herein is in lieu of all other warranties, express or implied, including without limitation any warranties or merchantability or fitness for a particular purpose and all such warranties are hereby disclaimed and excluded by the manufacturer. Repair or replacement of defective products as provided is the sole and exclusive remedy provided hereunder and the manufacturer shall not be liable for any further loss, damages or expenses, including incidental and consequential damages, directly or indirectly arising from the sale or use of this product.

This warranty is subject to the installation and operating conditions as described in this manual. This warranty does not apply to optional equipment which may have been supplied with your pump. Refer to the warranty supplied with the optional equipment for information on that equipment's warranty.

Parts originally manufactured by Magikist Ltd. must be used or this limited warranty will be voided. Magikist Ltd. will be absolved of any liability if parts other than Magikist Ltd. manufactured parts are used.

There are no warranties which extend beyond the description of the face thereof.