

SANDBLASTING HEAD and SAND POKER

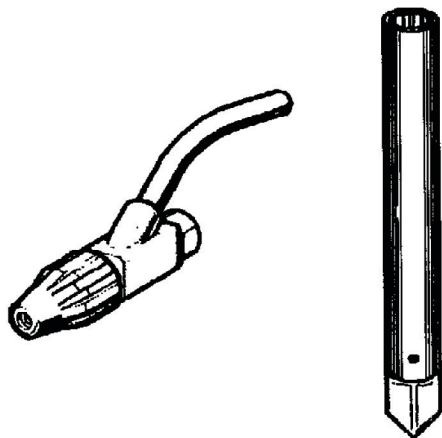

ZMSNDBLST

ZMSNDPOKER

SPECIFICATIONS

Part Number	ZMSNDBLST 0, 1, 2, 3, 4 or 5
Working Pressure	1000 - 3000 PSI
Volume	2.1 - 13.2 GPM
Sand Consumption	460 - 860 lbs./hr.
Maximum Water Temperature	158° F
Maximum Hose Length	20 ft.
Weight	1 lb.
Dimensions	7.0 x 1.3 x 2.5 in.

Part Number	ZMSNDPOKER
Weight	.3 lb
Dimensions	16.3 x Ø1.0 in.

PARTS LIST

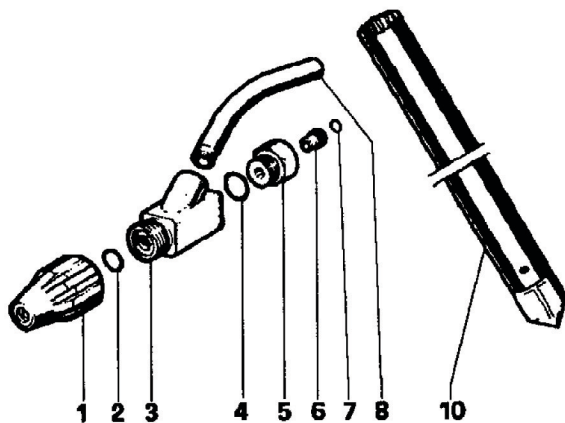

No.	Part No	Description	Qty.
1.	10.7050.01	Knob	1
2.	90.3828.00	O-Ring	1
3.	10.7062.01	Body	1
4.	90.3593.00	O-Ring	1
5.	10.0129.70	Inlet	1
6.	10.0141.66	Nozzle: #0, Ø1.5 mm	1
	10.0133.66	#1, Ø1.6 mm	
	10.0134.66	#2, Ø1.7 mm	
	10.0135.66	#3, Ø1.85 mm	
	10.0140.66	#4, Ø2.1 mm	
	10.0330.66	#5, Ø2.3 mm	
7.	90.3576.00	O-Ring	1
8.	10.0137.89	Tube Fitting	1
10.	ZMSNDPOKER	Sand Poker	1

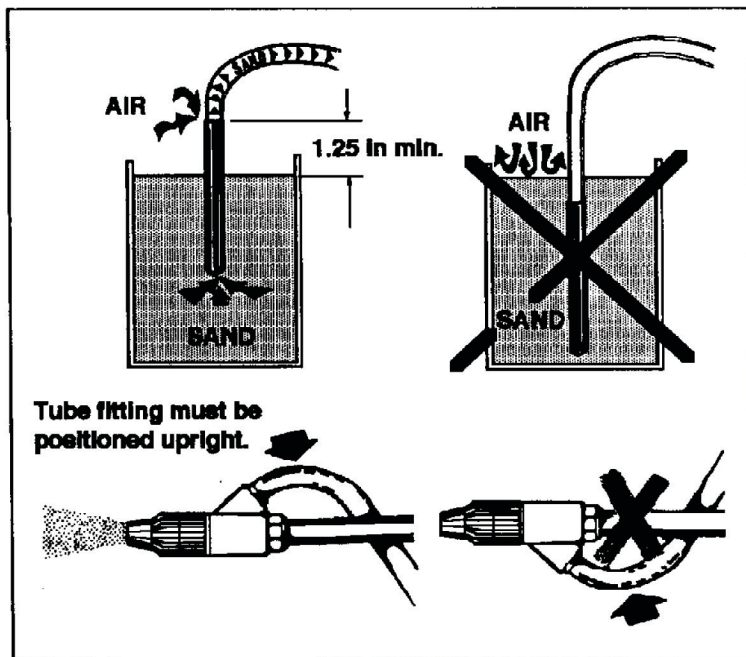

WARNING:

- Use proper eye and skin protection
- Do not direct spray at yourself or any other person.
- Keep hands clear of spray nozzle.

Place sand probe in sand leaving at least 1.25 inches above sand level to allow air flow to carry the sand. The sandblast head tube fitting (Item #8) must be upright when spraying for proper mixing and flow of sand.

