

GENERAL PUMP *A member of the Interpump Group*

T Series 47 S

20 mm bore / 14 mm stroke

FEATURES

- The preferred pump frame in the pressure cleaning industry
- Forged brass manifold with an exclusive lifetime warranty
- Large capacity, die-cast, anodized aluminum oil-bath crankcase
- Over-sized connecting rods for maximum life
- Heavy-duty tapered roller bearing
- Solid ceramic plungers with continuously lubricated packings
- Unitized stainless steel inlet and discharge valves
- Available in left-handed "L" version

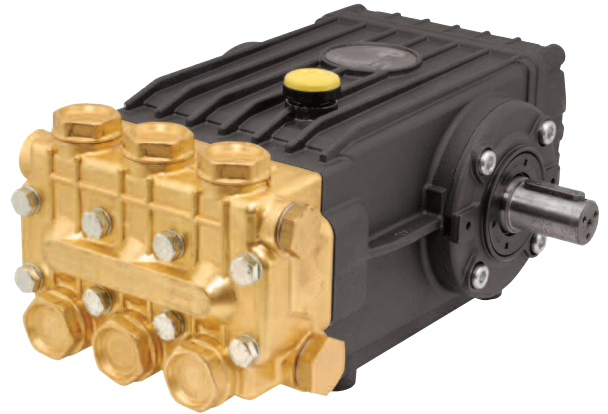

SPECIFICATIONS

Pump Model	TS1811	alternate spec	alternate spec
Maximum Volume	4.5 GPM	4.0 GPM	5.0 GPM
Maximum Discharge Pressure	3500 PSI		
Maximum Pump Speed	1450 RPM	1290 RPM	1610 RPM
Maximum Inlet Pressure	125 PSI		
Maximum Inlet Vacuum	9 ft. water (7.9 in. Hg)		
Bore	.787 in./20 mm		
Stroke	.551 in./14 mm		
Crankcase Oil Capacity	40.6 oz.		
Maximum Fluid Temperature	165° F		
Inlet Port Thread	1/2-14 BSPP-F		
Discharge Port Thread	3/8- BSPP-F		
Shaft Diameter	.945 in./24mm		
Weight	32 lbs.		
Dimensions	12.2" x 9.2" x 6.9"		

DIMENSIONS (Inches)

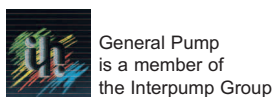
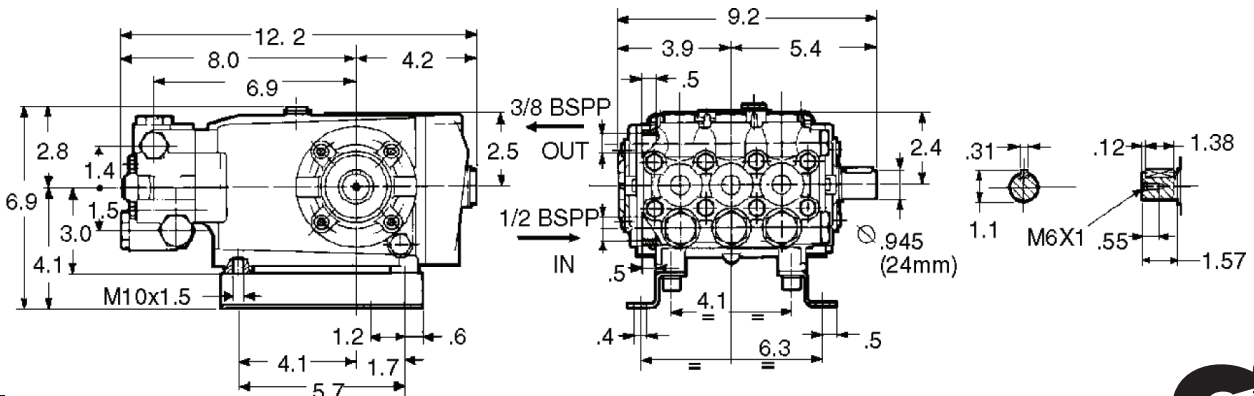

Ref 300318 Rev. D
02-13



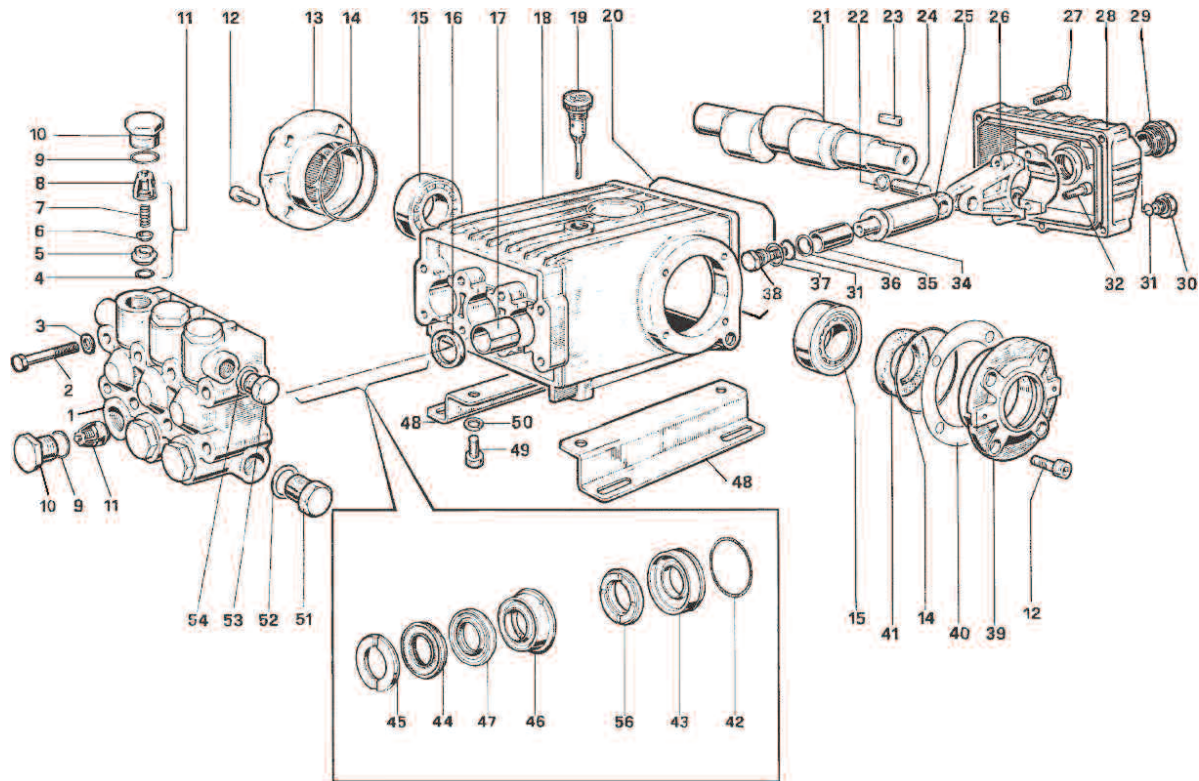

PART LIST

ITEM	PART NO.	DESCRIPTION	KIT NO.	QTY.	ITEM	PART NO.	DESCRIPTION	KIT NO.	QTY.	ITEM	PART NO.	DESCRIPTION	KIT NO.	QTY.
1.	47120841	Manifold, Brass		1	19.	98210600	Oil Dip Stick		1	37.	96728000	Washer	6	3
2.	99320600	Screw, M8 x 70		8	20.	90392200	O-ring, Cover		1	38.	47219566	Screw, Plunger	6	3
3.	203476	Washer, M8.4		8	21.	47022135	Crankshaft		1	39.	47151022	Cover, Crankcase		1
4.	701115	O-ring, .674x.103	1	6	22.	90055700	Ring, Snap		6	40.	97567800	Shim		2
5.	36200366	Seat, Valve	1	6	23.	640048	Key		1	41.	90164800	Seal, Oil	3	1
6.	36711501	Plate, Valve	1	6	24.	97738000	Pin, Wrist		3	42.	90361600	O-ring, 1.364x.070	10,28	3
7.	94737600	Spring	1	6	25.	47050554	Guide, Plunger		3	43.	47080570	Retainer, Packing	10,28	3
8.	36200251	Guide, Valve	1	6	26.	47030001	Rod, Connecting		3	44.	90270500	Packing	28,69	3
9.	701002	O-ring, .797x.103	4	6	27.	99191200	Screw, M6x30		5	45.	47100051	Ring, Head, M20	7,28	3
10.	98222000	Cap	4	6	28.	47160122	Cover, Crankcase		1	46.	47216970	Intermed. Ring	28,71	3
11.	100381	Valve Assembly	1	6	29.	97596800	Oil Indicator		1	47.	90270400	Restop Ring	28,69,71	3
12.	99303900	Screw, M8x16		8	30.	98204100	Cap		1	48.	47200074	Pump Feet		2
13.	47151201	Sight Glass Cover, Side		1	31.	701013	O-ring, .426x.070	6	4	49.	99364400	Screw, M10x18		4
14.	701147	O-ring, 2.675x.103		2	32.	99309900	Screw, M8x35		6	50.	96710600	Washer, M10.2		4
15.	640047	Bearing, Roller		2	33.	96701400	Washer, M8.4		6	51.	98217600	Cap		1
16.	90162500	Seal, Oil	2	3	34.	96728600	Washer, M14	6	3	52.	96751400	Washer, M21.5		1
17.	90912600	Bushing		3	35.	47040409	Plunger (20mm)		3	53.	98210000	Cap		1
18.	47010022	Crankcase		1	36.	660067	Ring, Back-up	6	3	54.	96738000	Washer, M17.5		1
										56.	90271000	Seal, L.P. 20mm.	28,69	3

REPAIR KITS

KIT NO.	1	2	3	4	6	7	10	28	69	71
ITEM NO's INCLUDED IN KIT	4, 5, 6, 7, 8, (11)	16	41	9, 10	31, 34, 36, 37, 38	45	42, 43	42, 43, 44, 45, 46, 47, 56	44, 47, 56	46, 47
NUMBER OF ASSEMBLIES IN KIT	6	3	2	6	3	6	3	1	3	3
NUMBER OF CYLINDERS KIT WILL SERVICE	3	3	-	3	3	3	3	1	3	3

TORQUE SPECS*

Pos.	Ft/lb	N-M
2	22.1	30
10	95.9	130
12	14.7	20
27	7.3	10
29	8.9	12
30	14.7	20
32	14.7	20
38	14.7	20
49	29.4	40
51	29.4	40
53	29.4	40

* Decrease torque by 20% if threads are lubricated