

36 mm bore - Triplex Plunger Pumps

## FEATURES

- The industry's choice for high-flow applications
- Large-capacity, die-cast anodized aluminum, oil-bath crankcase
- Over-sized connecting rods for maximum life
- Heavy-duty tapered roller bearing
- Solid ceramic plungers with continuously lubricated packings
- Unitized stainless steel inlet and discharge valves



## SPECIFICATIONS

Pump Model	T41
Maximum Volume	12.0 GPM
Maximum Discharge Pressure	900 PSI
Maximum Pump Speed	650 RPM
Maximum Inlet Pressure	125 PSI
Maximum Inlet Vacuum	9 ft. water (7.9 Hg)
Plunger Bore (in / mm)	1.417 in. / 36 mm
Plunger Stroke (in / mm)	.945 in. / 24 mm
Oil Capacity	50.7 oz.
Maximum Fluid Temperature	165°F
Inlet Port Thread	3/4-14 BSPP-F
Discharge Port Thread	3/8-19 BSPP-F
Shaft Diameter	1.378 in. / 35 mm
Weight	37 lbs.
Dimensions	12.9" x 11.9" x 7.3"

## DIMENSIONAL DRAWING

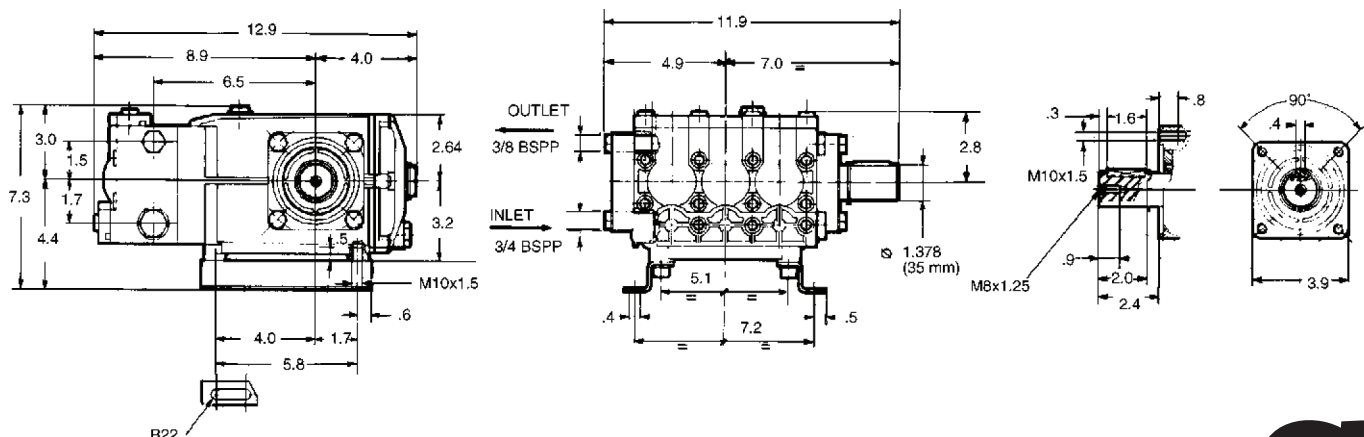

General Pump  
is a member of  
the Interpump Group



# T Series 69 - 36 mm Bore

**GENERAL PUMP** *A member of the Interpump Group*

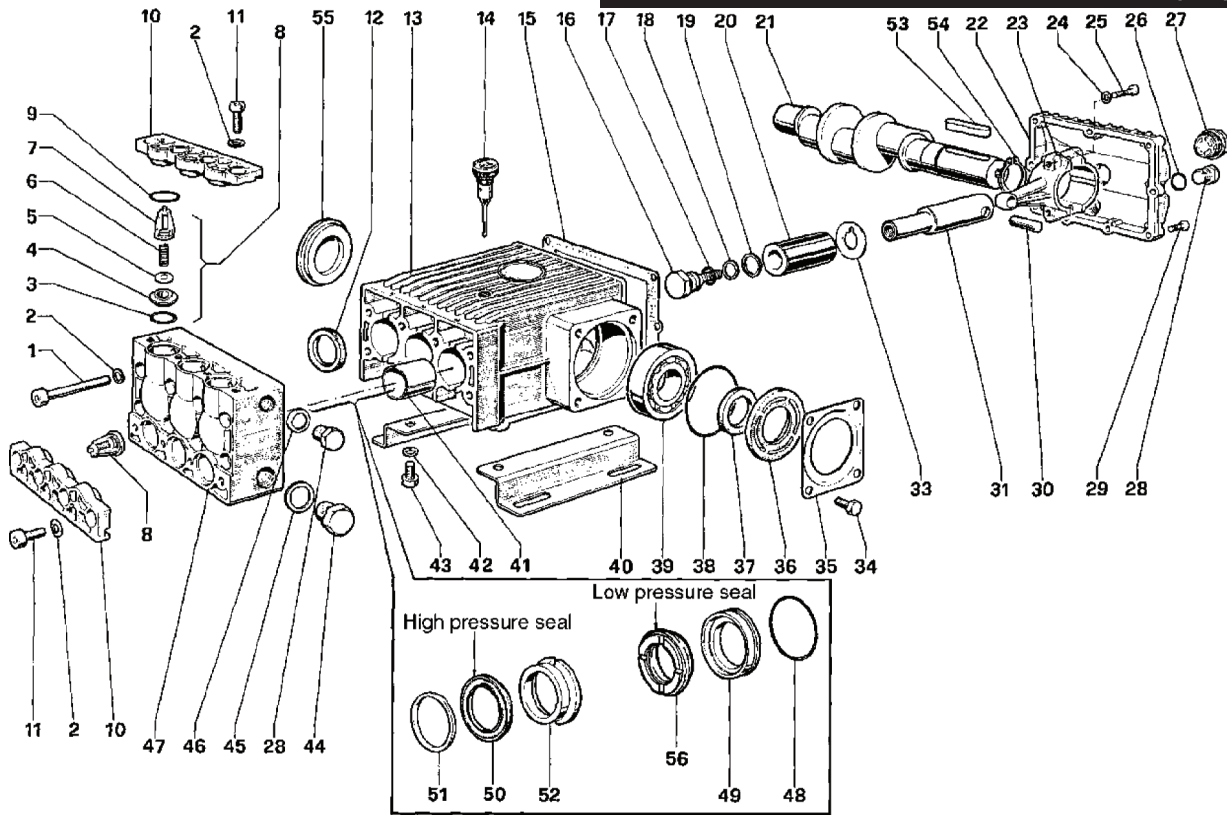

## PARTS LIST

ITEM	PART NO.	DESCRIPTION	KIT NO.	QTY.	ITEM	PART NO.	DESCRIPTION	KIT NO.	QTY.	ITEM	PART NO.	DESCRIPTION	KIT NO.	QTY.
1.	99378700	Screw		8	20.	69040009	Plunger (36 mm)		3	40.	47200074	Feet		2
2.	96710400	Washer		16	21.	69020535	Crankshaft		1	41.	90916200	Bushing		3
3.	90385900	O-ring	62	6	22.	69160022	Cover		1	42.	96710600	Washer		4
4.	36201766	Valve Seat	62	6	23.	69030001	Connecting Rod		3	43.	99364400	Screw		4
5.	36201876	Valve Plate	62	6	24.	96701400	Washer		6	44.	98226500	Cap		1
6.	94739400	Spring	62	6	25.	99309900	Screw		6	45.	96770000	Washer		1
7.	36200851	Valve Guide	62	6	26.	90383300	O-ring		1	46.	96738000	Washer		1
8.	36706001	Valve Assy.	62	6	27.	97596800	Oil Level Indicator		1	47.	69120022	Manifold		1
9.	90405500	O-ring		6	28.	98210000	Cap		2	48.	701133	O-ring	39, 40	3
10.	69218022	Valve Cover		2	29.	99186700	Screw		9	49.	69080270	Packing Retainer	39, 40	3
11.	99366900	Screw		8	30.	97739800	Pin		3	50.	90282000	Packing	38, 39	3
12.	90165600	Oil Seal	37	3	31.	69050022	Plunger Guide		3	51.	69100293	Head Ring	39, 41	3
13.	69010022	Crankcase		1	32.	96756500	Washer		3	52.	69216870	Intermediate Ring	39, 42	3
14.	98210600	Oil Dip Stick		1	33.	99363600	Screw		8	53.	91496900	Key		1
15.	69211984	Cover Gasket		1	34.	68150074	Cover		2	54.	90069500	Retaining Ring		1
16.	69219566	Plunger Screw	74	3	35.	69211551	Spacer		1	55.	69211651	Spacer		1
17.	90384100	O-ring	74	3	36.	90167200	Oil Seal	32	1	56.	90282300	Seal, L.P., 36 mm	38, 39	3
18.	90510700	Anti-ext. Ring	74	3	37.	90413100	O-ring		2					
19.	96755500	Washer	74	3	38.	91848000	Bearing		2					
					39.				2					

## REPAIR KITS

KIT NO.	32	37	38	39	40	41	42	62	74
ITEM NO's INCLUDED IN KIT	37	12	50, 56	48, 49, 50, 51, 52, 56	48, 49	51	52	3, 4, 5, 6, 7, (8)	16, 17, 18, 19
NUMBER OF ASSEMBLIES IN KIT	2	3	3	1	3	6	3	6	3
NUMBER OF CYLINDERS KIT WILL SERVICE	-	3	3	1	3	3	3	3	3

## TORQUE SPECS\*

Position	Ft.-Lbs	Nm
1	29.4	39.8
11	44.2	59.9
16	29.4	39.8
25	14.7	19.9
27	13.2	17.9
28	29.4	39.8
29	7.3	9.9
34	29.4	39.8
49	29.4	39.8
44	51.5	69.8

\* Decrease torque by 20% if threads are lubricated

