

## FEATURES

- Features patent-pending “high tech” packings:
  - dynamic low-pressure seal retainer
  - superior low-pressure seal
  - innovative intermediate ring
  - superior high-pressure seal
- Ceramic plungers
- Patent-pending inlet/outlet valve cage
- Nickel-plated forged brass manifold with an exclusive lifetime warranty
- Heavy-duty tapered roller bearings
- Specifically designed to handle rigorous duty cycles, high temperatures and chemicals
- Ideal for use in car wash and other high pressure cleaning applications

**Emperor**  
Pumps That Rule Any Environment



## SPECIFICATIONS

Pump Model	HTS2016S
Maximum Volume	5.6 GPM
Maximum Pressure	3000 PSI
Maximum RPM	1450 RPM
Maximum Inlet Pressure	125 PSI
Minimum Inlet Pressure	9 ft. water (7.9 in. Hg)
Maximum Fluid Temperature	185°F
Bore (in / mm)	.787 in. / 40 mm
Stroke (in / mm)	.630 in. / 16 mm
Oil Capacity	40.6 oz.
Inlet Port Thread	1/2"-14 BSP-F
Discharge Port Thread	3/8"-19 BSP-F
Shaft Diameter	.945 in. / 24 mm
Weight	32 lbs.
Dimensions - Nominal	12.4" x 10.0" x 6.9"

EMPEROR

EMPEROR



General Pump  
is a member of  
the Interpump Group

Ref 300628 Rev. E  
11-14



# Instructions and Recommendations for the Installation of *HT Series Pumps*

The high-temperature pumps of the HT series have been designed for use in applications where the water must be pre-heated, such as in carwash, food and pharmaceutical industries.

Maximum temperature of the water through the pump is 185°F (85°C).

In order to obtain maximum performance in terms of duration of seals and valves, it is necessary to respect a few simple rules, as follows:

**1) In order to avoid damage caused by cavitation, the pump must be pressure fed.**

The higher the inlet pressure, the longer the life of the wet end of the pump.

When working at 185°F (85°C), the minimum feed pressure - measured directly in the inlet port of the pump when it is working - is 45 psi (3 bar).

The minimum feed pressure according to the different temperatures are:

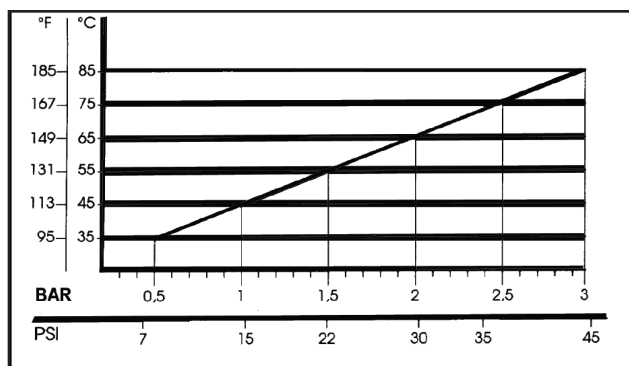

Naturally, if the application allows for feeding the pump with 45 psi (3 bar) even at low temperatures (for example: 115°F/45°C) the life of the wet end of the pump will be even longer.

**2) The plumbing which feeds the pump must be of a diameter at least equal to the inlet port.**

Also, follow the suggestions below:

a) Make the plumbing as short and straight as possible, preferably in an upward direction to facilitate the expulsion of eventual air bubbles naturally if compatible with the requirements of the system.

b) It is always useful to put a filter at the inlet with capacity of 4 to 5 times the flow of

the pump, for example for a 4 gpm (15 l/min) pump, put a filter from 16 to 20 gpm (60-75 l/min). The mesh size suitable for this application is 0.016" (.4 mm).

c) It is extremely important to put a pressure switch on the suction port of the pump, and in any case downstream from the filter, so that it can stop the pump should the feed pressure drop by 20% due to the filter clogging or failure of the feed pump, etc.

**3) Change of oil**

We recommend the **first oil change after the first 50 hours**, with the **pump stopped** and the **oil still warm**.

This change is not recommended because the oil has lost its properties, but rather to eliminate the impurities that have gotten into the oil during the running-in phase. If these impurities are not removed, but are allowed to remain in the oil, they *may cause premature wear* to the moving parts and the oil seals. **After this initial change, the oil can then be changed every three months or 300 hours of operation thereafter.**

Please note: If the pump works in conditions with high humidity and with sharp temperature changes, it is possible that condensation will appear inside the crankcase, which mixing with the oil can change its properties. This is easy to see because the oil changes to a white, milky color.

If the pump does not have excessive water leaking from the packings, and the oil becomes milky, the oil has to be changed more frequently. The percentage of water in the oil must not exceed 20%.

**Use oil per the following chart:**

CHART OF COMPATIBLE OILS SAE15W40	
GENERAL PUMP	SERIES 100
BP	VISCO 2000
CASTROL	CWX
MOBIL	SUPER
SHELL	HELIX SUPER
TOTAL	QUARTZ 4000-5000

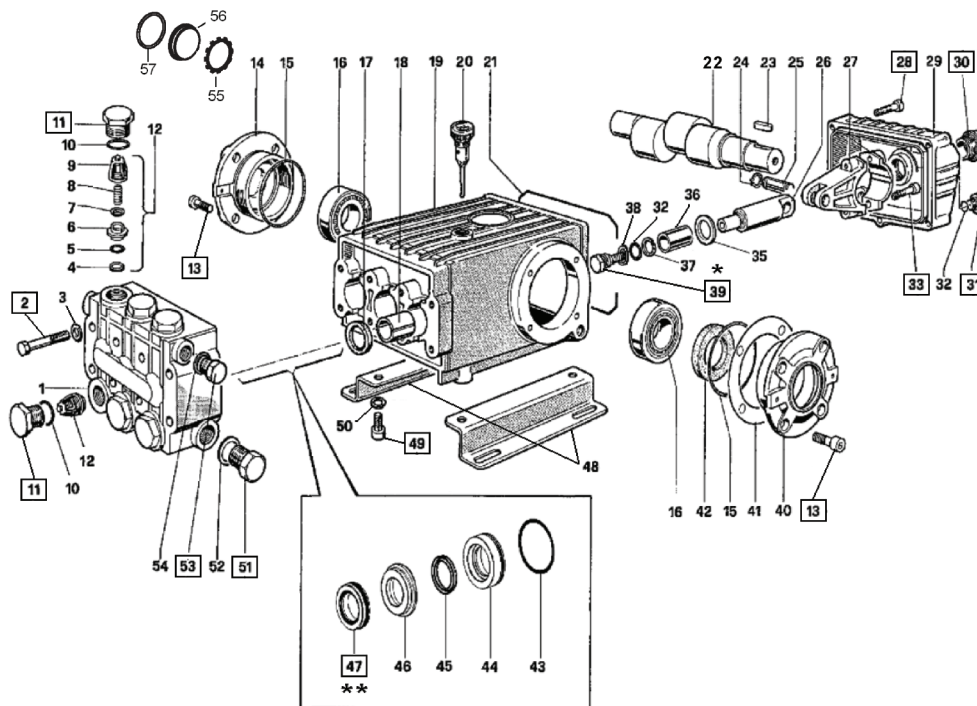

**PARTS LIST**

ITEM	PART NO.	DESCRIPTION	QTY	ITEM	PART NO.	DESCRIPTION	QTY	ITEM	PART NO.	DESCRIPTION	QTY
1.	47120941	Manifold, Nickel-plated	1	20.	98210600	Dipstick, Vented	1	39.	47219566	Plunger Screw	3
2.	99320600	Head Bolt, M8	8	21.	90392200	O-ring	1	40.	47150022	Crankcase Cover, Open	1
3.	96702000	Washer, M8	8	22.	47021735	Crankshaft, HTS2016S	1	41.	97567800	Spacer	2
4.	90510500	Anti-extrusion Ring	6	23.	91489200	Key	1	42.	90164800	Crankshaft Oil Seal	1
5.	90340000	Seal Ring	6	24.	90055700	Circlip	6	43.	90361600	O-ring	3
6.	36200366	Valve Seat	6	25.	97738000	Wrist Pin	3	44.	47081770	Seal Retainer, 20 mm	3
7.	36200176	Valve Poppet	6	26.	47050454	Plunger Guide	3	45.	90225000	L.P. Seal, 20 mm	3
8.	94737600	Valve Spring	6	27.	47030001	Connecting Rod	3	46.	47217870	Intermed. Ring, 20 mm	3
9.	36200251	Valve Guide	6	28.	99191200	Screw, M6	5	47.	90226200	H.P. Seal, 20 mm	3
10.	701002	O-ring	6	29.	47160122	Crankcase Cover, Rear	1	48.	47200074	Pump Rail	2
11.	98222200	Valve Cap, Nickel-plated	6	30.	97596800	Oil Level Indicator	2	49.	99364400	Screw, M10	4
12.	36704901	Valve, Complete	6	31.	98204100	Plug, 1/4"	1	50.	96710600	Washer, M10	4
13.	99303900	Screw, M8	8	32.	701013	O-ring	4	51.	98217900	Plug, Nickel-plated, G1/2"	1
14.	47150622	Side Cover	1	33.	99309900	Screw, M6	6	52.	96751400	Washwe, M21.5	1
15.	701147	O-ring	2	34.	96701400	Lock Washer, M8.4	6	53.	98209900	Plug, Nickel-plated, G3/8"	1
16.	91837800	Vearing, Tapered Roller	2	35.	96728600	Flinger Washer	3	54.	96738000	Washer, M17.5	1
17.	90162500	Plunger Rod Oil Seal	3	36.	47040409	Plunger, 20 mm	3	55.	70211801	Oil Sight Glass	1
18.	90912600	Guide, Bushinh	3	37.	90506700	Back-up Ring	3	56.	90075600	Retainer Clip	1
19.	47010022	Crankcase	1	38.	96728000	Washer, M14	3	57.	90387700	O-ring, 39.34x2.62	1

**REPAIR KITS**

KIT NO.	K02	K03	K05	K06	K201	K238	K239B
ITEM NO'S INCLUDED IN KIT	17	42	10, 11	32, 35, 37, 38, 39	4, 5, 6, 7, 8, 9, (12)	45, 47	43, 44, 45, 46, 47
NUMBER OF ASSY'S IN KIT	3	2	3	1	6	3	1
NO. OF CYLINDERS KIT SERVICES	3	-	3	1	3	3	1

**TORQUE SPECS\***

Position	Ft.-Lbs.	Nm.
2	22.1	30
11	95.9	130
13	14.7	20
28	7.3	10
30	13.2	18
31	14.7	20
33	14.7	20
39**	14.7	20
49	29.4	40
51	29.4	40
53	29.4	40

**DIMENSIONS**

