

FEATURES

- Triplex plunger pump
- New Forged brass manifold , increases working pressure to 4,000 PSI
- New plunger guide bushing (patent pending)
- Solid ceramic plungers with dual guide system
- New dual diameter plunger guide
- New optimized outlet valves
- New dual lip oil seal
- Hollow shaft, flanged for direct couple to electric motors (NEMA184TC))



SPECIFICATIONS

Pump Model	EP1510E17	EP1512E17	EP1810E17	EP1811E17	EP1812E17
Maximum Volume	2.1 GPM	2.9 GPM	3.4 GPM	3.7 GPM	4.0 GPM
Maximum Discharge Pressure	3,045 PSI		2,500 PSI		
Horsepower	4.4 HP	6.0 HP	5.7 HP	6.2 HP	6.6 HP
Maximum Pump Speed	1750 RPM				
Maximum Inlet Pressure	125 PSI				
Maximum Inlet Vacuum	3 ft. water (2.6 Hg)				
Plunger Bore	.591 in./15 mm		.709 in./18 mm		
Plunger Stroke	.394 in./10 mm	.472 in./12 mm	.394 in./10 mm	.433 in./11 mm	.472 in./12 mm
Oil Capacity	15 oz.				
Maximum Fluid Temperature	165° F				
Inlet Port Thread	1/2"-14 BSP-F				
Discharge Port Thread	3/8"-19 BSP-F				
Shaft Diameter	1.125 in./28.58 mm				
Weight	15.4 lbs.				
Dimensions	9.7" x 8.45" x 6.3"				

TRIPLEX

TRIPLEX



General Pump
is a member of
the Interpump Group

Ref 300921 Rev.C
03-15



Instructions and Recommendations for the Installation of *EP Series Pumps*

Maximum temperature of the water through the pump is 165°F (73°C).

In order to obtain maximum performance in terms of duration of seals and valves, it is necessary to respect a few simple rules, as follows:

1) **In order to avoid damage caused by cavitation, the pump must be pressure fed.**

The higher the inlet pressure, the longer the life of the wet end of the pump.

When working at 165°F (73°C), the minimum feed pressure - measured directly in the inlet port of the pump when it is working - is 45 psi (3 bar).

The minimum feed pressure according to the different temperatures are:

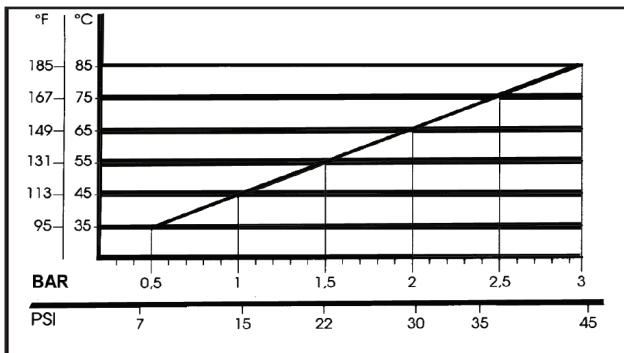

Naturally, if the application allows for feeding the pump with 45 psi (3 bar) even at low temperatures (for example: 115°F/45°C the life of the wet end of the pump will be even longer.

2) **The plumbing which feeds the pump must be of a diameter at least equal to the inlet port.**

Also, follow the suggestions below:

a) Make the plumbing as short and straight as possible, preferably in an upward direction to facilitate the expulsion of eventual air bubbles naturally if compatible with the requirements of the system.

b) It is always useful to put a filter at the inlet with capacity of 4 to 5 times the flow of

the pump, for example for a 4 gpm (15 l/min) pump, put a filter from 16 to 20 gpm (60-75 l/min). The mesh size suitable for this application is 0.016" (.4 mm).

c) It is extremely important to put a pressure switch on the suction port of the pump, and in any case downstream from the filter, so that it can stop the pump should the feed pressure drop by 20% due to the filter clogging or failure of the feed pump, etc.

3) **Change of oil**

We recommend the **first oil change after the first 50 hours**, with the **pump stopped** and the **oil still warm**.

This change is not recommended because the oil has lost its properties, but rather to eliminate the impurities that have gotten into the oil during the running-in phase. If these impurities are not removed, but are allowed to remain in the oil, they *may cause premature wear* to the moving parts and the oil seals. **After this initial change, the oil can then be changed every three months or 300 hours of operation thereafter.**

Please note: If the pump works in conditions with high humidity and with sharp temperature changes, it is possible that condensation will appear inside the crankcase, which mixing with the oil can change its properties. This is easy to see because the oil changes to a white, milky color.

If the pump does not have excessive water leaking from the packings, and the oil becomes milky, the oil has to be changed more frequently. The percentage of water in the oil must not exceed 20%.

Use oil per the following chart:

CHART OF COMPATIBLE OILS SAE15W40	
General Pump	Series 100
BP	VISCO 2000
CASTROL	CWX
MOBIL	SUPER
SHELL	HELIX SUPER
TOTAL	QUARTZ 4000-5000

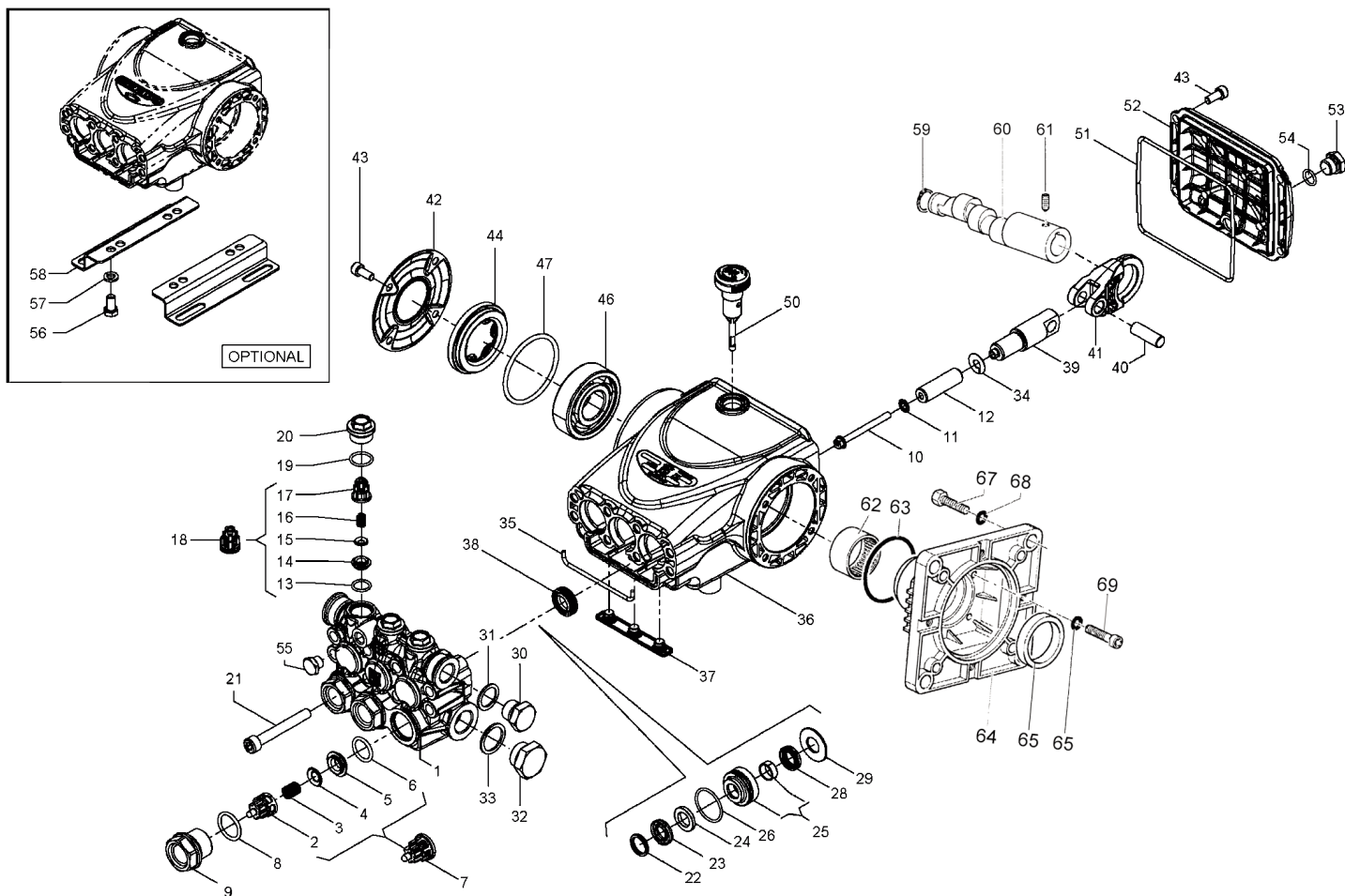

PARTS LIST

ITEM	PART NO.	DESCRIPTION	QTY	ITEM	PART NO.	DESCRIPTION	QTY	ITEM	PART NO.	DESCRIPTION	QTY	
1.	58120041	Manifold, Ø 13	1	23.	90260200	Packing, Ø 13, HP	3	41.	58030022	Connecting Rod	3	
	58120141	Manifold, Ø 15	1		90261100	Packing, Ø 15, HP	3	44.	44211801	Sight Glass	1	
	58120141	Manifold, Ø 18	1		90265300	Packing, Ø 18, HP	3	47.	90409700	O-ring, Ø 55.56x3.53	1	
2.	36202551	Valve Cage	3	24.	90507650	Anti-ext. Ring, Ø 13	3	50.	98210500	Oil Dipstick	1	
3.	94737600	Spring, Ø 9.4x14.8	3		90508990	Anti-ext. Ring, Ø 15	3	51.	90392550	O-ring, Ø 113.97x2.62	1	
4.	36711501	Valve	3		90511150	Anti-ext. Ring, Ø 18	3	52.	58160022	Rear Cover	1	
5.	36200366	Valve Seat	3	25.	58605601	Intermed. Ring, Ø 13	3	53.	98204100	Plug, 1/4"x9	1	
6.	701115	O-ring, Ø17.13x2.62	3		58605701	Intermed. Ring, Ø 15	3	54.	701013	O-ring, Ø 10.82x1.78	1	
7.	36711501	Valve Assembly	3		58605801	Intermed. Ring, Ø 18	3	55.	98196600	Plug, 1/8"x8	1	
8.	701002	O-ring, Ø20.24x2.62	3	26.	701023	O-ring, 26.7x1.78	3	56.	99303700	Screw, Hex Head	4	
9.	98222600	Valve Cap, M24x1.5x16.7	3	28.	90260100	Seal, Ø 13, LP	3	57.	96701600	Washer, Ø 8.4	4	
10.	99169000	Plunger Bolt, M5x55	3		90260800	Seal, Ø 15, LP	3	58.	50200074	Pump Foot	2	
11.	96690500	Washer, Ø 5x11.5x0.4	3		90265000	Seal, Ø 18 LP	3	59.	90063500	Circlip	1	
12.	58040009	Plunger, Ø 13x42	3	29.	58210670	Support Ring, Ø 13	3	60.	63023265	Crankshaft, 10 mm	1	
	58040109	Plunger, Ø 15x42	3		58210770	Support Ring, Ø 15	3		63023665	Crankshaft, 12 mm	1	
	58040209	Plunger, Ø 18x42	3		58210870	Support Ring, Ø 18	3		63029465	Crankshaft, 11 mm	1	
13.	701014	O-ring, Ø 12.42x1.78	3	30.	98210000	Plug, 3/8"x13	1		61.	99179000	Set Screw, M6x6	1
14.	36211366	Outlet Valve Seat	3	31.	96738000	Gasket, 17.5x23x1.5	1	62.	91856800	Needle Bearing	1	
15.	36211276	Outlet Valve Poppet	3	32.	98217600	Plug, 1/2" BSPx10	1	63.	90409700	O-ring, Ø 55.56x3.56	1	
16.	94733300	Spring, Ø 6.2x10.4	3	33.	96751400	Gasket, Ø 21.5x27x1.5	1	64.	10050422	Electric Flange	1	
17.	36211151	Outlet Valve Cage Guide	3	34.	96698000	Washer, Ø 7.5x15x0.5	3	65.	90168700	Oil Seal	1	
18.	36719301	Complete Outlet Valve	3	35.	58210582	Gasket, Ø 3x94	1	66.	203510	Washer, Ø 6.4x10x0.7	4	
19.	701016	O-ring, Ø 15.6x1.78	3	36.	58010022	Crankcase	1	67.	99460000	Screw, Hex, 1/2"x1-1/4"	4	
20.	98213700	Outlet Valve Cap, M18x1.5x10	3	37.	58210451	Drip Cover	1	68.	96719500	Washer, Ø 13x18x1.1	4	
21.	99317500	Screw, M8x60	8	38.	90156550	Oil Seal, Ø 15x24x5.7	3	69.	99191200	Screw, M6x30	4	
22.	44100251	Head Ring, Ø 13	3	39.	58050066	Piston Guide	3					
	63101051	Head Ring, Ø 15	3	40.	97734000	Piston Pin, Ø 10x29.5	3					
	63101151	Head Ring, Ø 18	3									

REPAIR KITS

KIT NO.	K269	K270	K271	Ø 15		Ø 18	
				K273	K276	K274	K277
ITEM NO'S INCLUDED IN KIT	2, 3, 4, 5, 6, 13, 14, 15, 16, 17, (7), (18)	8, 9, 19, 20	38	22, 23, 24, 26, 28	22, 23, 24, 25, 26, 28, 29	22, 23, 24, 26, 28	22, 23, 24, 25, 26, 28, 29
NUMBER OF ASSY'S IN KIT	6	6	3	3	1	3	1
NO. OF CYLINDERS KIT SERVICES	3	3	3	3	1	3	1

TORQUE SPECS*

Position	Ft.-Lbs.	Nm.
9	96	130
10	4.5	6
20	44.3	60
21	14.8	20
30	30	40
32	30	40
43	7.4	10
53	14.8	20
55	9.6	13
56	14.8	20
69	7.4	10

*Decrease torque by 20% if threads are lubricated.
**Use Loctite 542 Red

DIMENSIONS

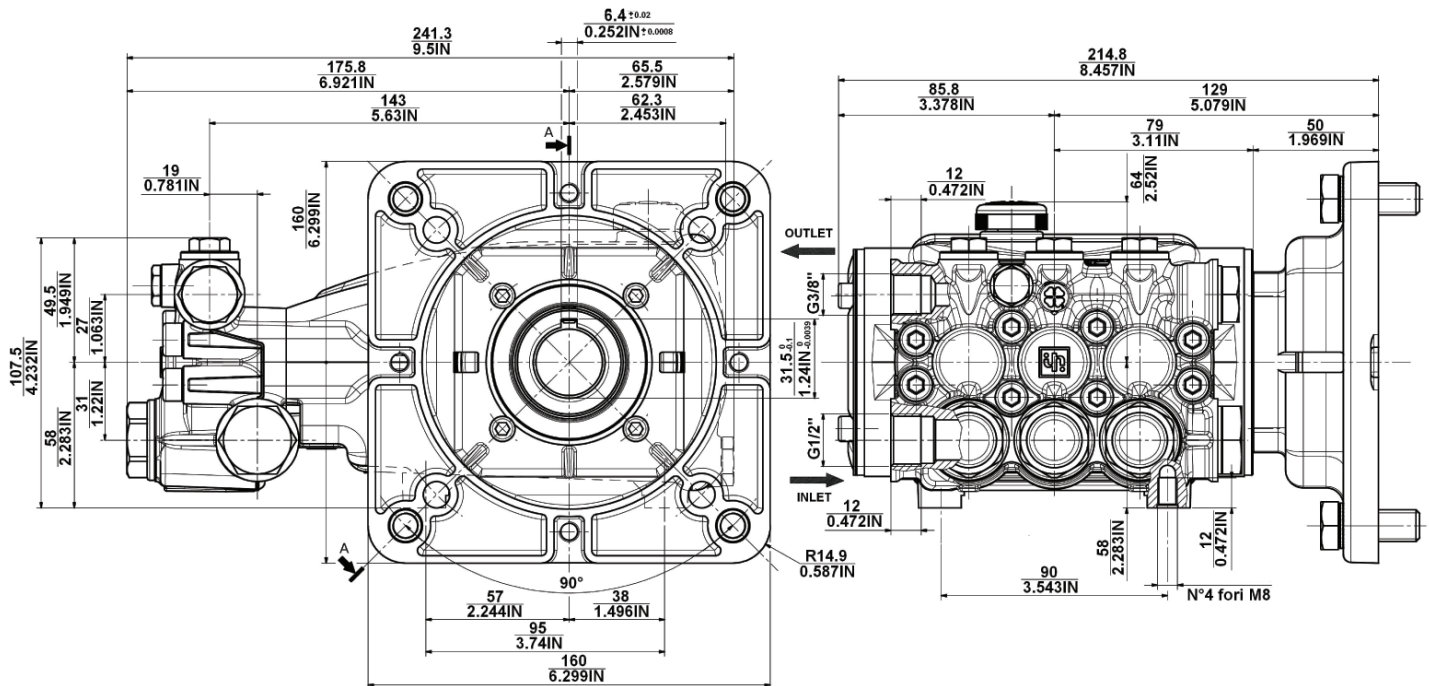

Ref 300921 Rev.C
03-15

