

SAFETY PRECAUTIONS

1. Make sure incoming pressure does not exceed the rated pressure.
2. Use proper eye protection when assembling and using the hose reel.
3. Assemble the hose reel on a clean workbench free of debris and moisture.
4. Use soap and water when checking for air leaks.
5. Keep children away from work area.

WARNING!

Exposure of skin directly to pressurized air or fluids could result in severe bodily injury!

Ref 300631 Rev. F
05-12

General Pump
1174 Northland Drive • Mendota Heights, MN 55120
Phone: 651.686.2199 • Fax: 800.535.1745
www.generalpump.com • email: sales@gpcompanies.com



- DIRECT HAND-CRANK REWIND WITH LOCKING MECHANISM
- SOLID STEEL CONSTRUCTION
- DURABLE POWDERCOAT FINISH
- FULL FLOW SWIVEL BRASS JOINT

INDUSTRIAL HOSE REELS

FROM GENERAL PUMP

DHR50100D
DHR50150D
DHR50200D

OPERATOR'S MANUAL

Ref 300631 Rev. F
05-12



General Pump
is a member of
The Interpump Group



ASSEMBLY AND OPERATING INSTRUCTIONS

1. Connect the handle to the flange. Nuts go on handle side of flange.
2. Use (4) 3/8" or 10 mm bolts when securing the hose reel to ceiling or wall.
3. Use the provided nuts, bolts and mounting bracket when securing hose reel to a cart.
4. Use thread sealant (not provided) on inlet threads and on outlet hose (not provided).
5. Attach pigtail end to high pressure pump outlet.
6. Attach hose reel hose to swivel on hose reel
7. The hose reel is ready for operation.

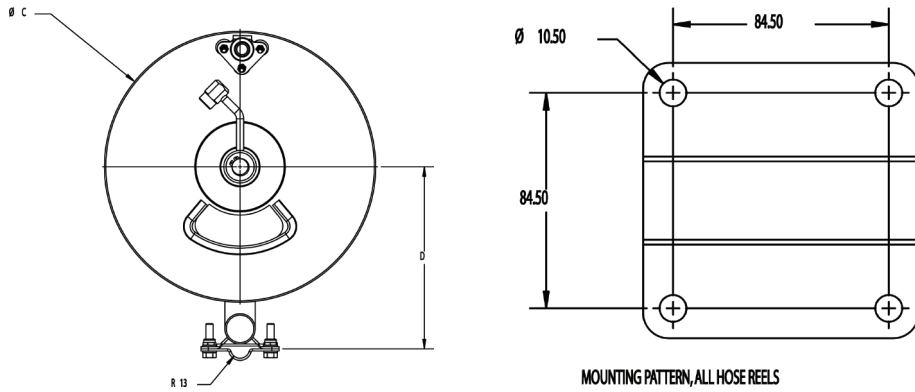

MOUNTING PATTERN, ALL HOSE REELS

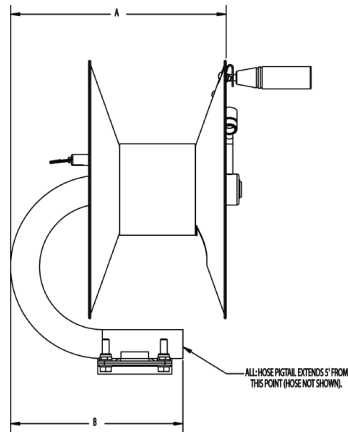

	Dimensions (mm)			
	A	B	C	D
DHR50100D	313.4	250.4	375.5	252.4
DHR50150D	411.5	348.4	375.5	252.4
DHR50200D	503.5	364.4	375.5	252.4

Ref 300631 Rev. F
05-12

SPECIFICATIONS

Model	3/8" Capacity	Swivel Pressure Rating	Inlet	Outlet
DHR50100D	100 Ft.	5000 PSI	3/8" NPT-M	3/8" NPT-F
DHR50150D	150 Ft.			
DHR50200D	200 Ft.			

MAXIMUM TEMPERATURE RATING: 185°F

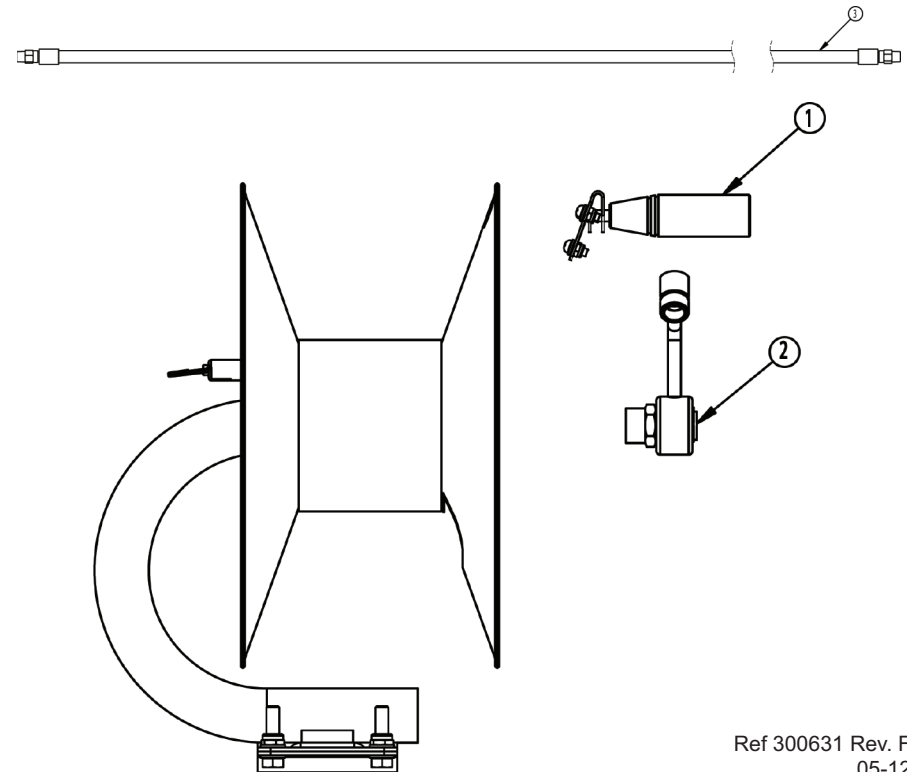

Ref 300631 Rev. F
05-12

PARTS LIST

	Item		
	1	2	3
DHR50100D	100056	2103051	2702006
DHR50150D	100056	2103051	2702009
DHR50200D	100056	2103051	2702050
2100278	SWIVEL REPAIR KIT		