

BERKELEY® BPD Series Self-Priming Corrosion-Resistant Sprinkler Pumps



Quick priming BPD Series Pumps feature lightweight construction in a self-priming design. These models offer a stronger pump body with reinforcement ribs and also a new 2" suction that is designed for the professional pump contractor.

APPLICATIONS

- Lawn and landscape sprinkling; self primer out of tanks or cisterns.
- Light chemical transfer for compatible fluids.

ORDERING INFORMATION

Catalog Number	HP	Pipe Tapping Sizes		Motor Voltage	Approx. Wt. Lbs.
		Suction	Discharge		
BPDH10	1	2"	1-1/2"	115/230	38
BPDH15	1-1/2	2"	1-1/2"	115/230	41
BPDH20	2	2"	2"	230	52
BPDH25	2-1/2	2"	2"	230	54

NOTE: All motors are shipped from the factory set at 230 Volt.

1 and 1-1/2 HP pumps also feature dual voltage motors. Easy to change voltage settings require switching only 2 wires to reset voltage. Just remove the dust cover and change the 2 leads on the terminal board as shown on motor nameplate.

SPECIFICATIONS

Body and Base – Fiberglass-reinforced thermoplastic

Impeller – Engineered polymer

Diffuser – Polypropylene

Shaft – 300 stainless steel

FEATURES

Quality Construction – Fiberglass-reinforced thermoplastic provides total corrosion resistance and high resistance to sandy water.

Lightweight Design – Space-age materials make these pumps more portable than conventional cast iron pumps.

Composite Impeller – Highest performance and efficiency from ultra-smooth materials precision molded for perfect balance.

Easily Serviced – Normal wearing parts are easily accessible for service and replacement, without disturbing piping or mounting.

Dustproof Cover – Electrical components protected from dust and insects.

Heavy-Duty Motor – Heavy-duty 1 through 2-1/2 HP motors. Designed for continuous operation. Stainless steel shaft.

Dual Voltage Capability – 1 and 1-1/2 HP motors have dual voltage motors and are shipped at the 230 Volt setting. 2 and 2-1/2 HP are 230 Volt setting only.

BERKELEY® BPD Series Self-Priming Corrosion-Resistant Sprinkler Pumps

OUTLINE DIMENSIONS

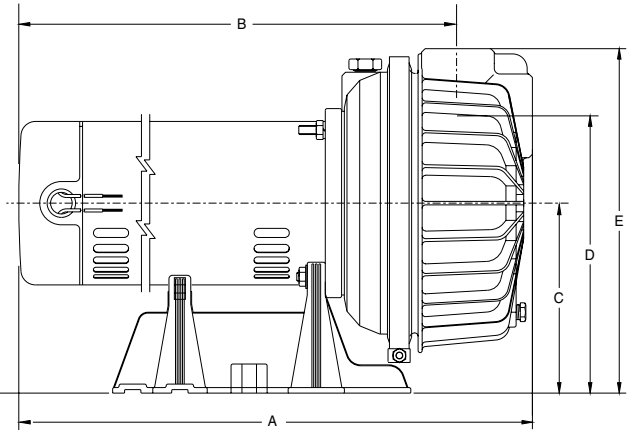

Catalog Number	A	B	C	D	E
BPDH10	18-5/8	16-1/8	6-9/16	9-9/16	11-13/16
BPDH15	19-3/4	17-1/4	6-9/16	9-9/16	11-13/16
BPDH20	21	17-3/16	6-9/16	8-7/8	12-3/8
BPDH25	21	17-3/16	6-9/16	8-7/8	12-3/8

Dimensions (in inches) are for estimating purposes only.

PERFORMANCE (Capacity in Gallons Per Minute)

Disch. Press. PSI	BPDH10					BPDH15					BPDH20					BPDH25									
	Distance Above Water																								
	5'	10'	15'	20'	25'	5'	10'	15'	20'	25'	5'	10'	15'	20'	25'	5'	10'	15'	20'	25'					
10	53	52	50	48	46	67	66	64	61	59	70	69	67	64	62	90	88	86	82	80					
20	45	42	39	37	35	59	56	54	50	47	61	59	56	53	50	79	76	72	70	65					
30	35	31	27	24	18	48	44	40	37	32	50	48	44	41	37	66	62	57	55	50					
40	17	10				31	26	20	10		36	33	25	23	19	50	45	42	37	32					
50											16	9				30	23	20							

PUMP PERFORMANCE

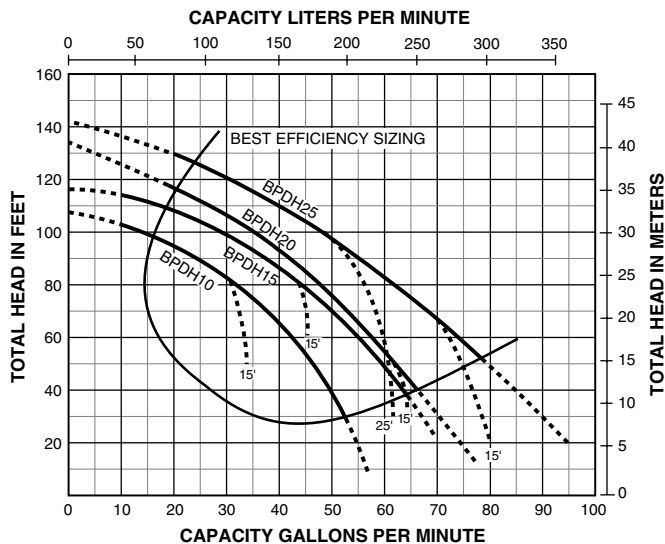

NOTE: Dotted lines indicate performance reduction at high suction lift.

