

**Pump Thermal Protectors**

Protects the pump from damaging heat build-up while it is in bypass mode. The thermal relief valve, sensing a rise in temperature, opens and discharges a small amount of heated fluid. This allows cooler water to enter the system and cool the pump. When the gun is discharged the cooler water will cause the valve to close immediately.

**FEATURES/BENEFITS**

- Most consistent temperature range on the market
- Quickest response to rising temperature
- Less stress on pump
- Most cost effective thermal protector in the market
- Mounts easily in the pump manifold, inlet water supply or bypass loop plumbing

**SPECIFICATIONS**

Part Number	Temperature	Description
100556	145 - 147° F	1/4" NPT
100557	145 - 147° F	3/8" NPT
100558	145 - 147° F	1/2" NPT
Hose Barb		90° , 1/4"
Weight		1.5 oz.
Dimensions		1-1.2" H x 1" W
Materials		Brass, Buna, Delrin, Stainless Steel

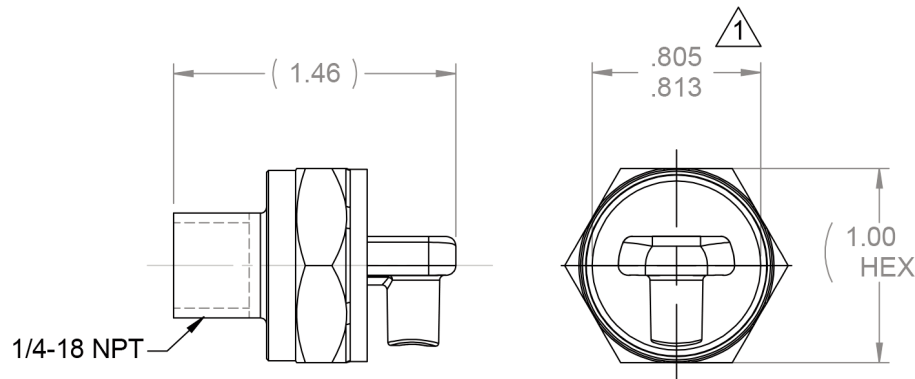
**FEATURES/BENEFITS****SPECIFICATIONS**

General Pump  
is a member of  
the Interpump Group

Ref 300963 Rev B  
05-17



**GENERAL PUMP** • 1174 Northland Drive • Mendota Heights, MN 55120  
Phone: 651.686.2199 • Fax: 800.535.1745 • email: sales@gpcompanies.com • www.generalpump.com