



Train Kitchen / 3D Central

UNION PACIFIC O-50-6 TANK CAR



First of all

I'm Sarah Griessenboeck and I'll guide you through the process of building the tank car. Careful planning went into the project and 3D central brought a ton of expertise and skill to print the parts.

You now own a resin freight car, a highly detailed model kit but building and handling the model will require more care than you might have been used to. I designed the parts to withstand operation on a layout, cut into a long and heavy consist. The brass weight serves as a stress absorber and does most of the pushing and pulling, not the resin. I'd say let's start!

Prototype Info

Union Pacific Class O-50-6 Tank Car	
Builder	GATC
Year Built	1937
Quantity	200
Numbers	69000 - 69199
Capacity	12,500 gallons
Trucks	National B
Decals	currently being made in cooperation with UP specialists

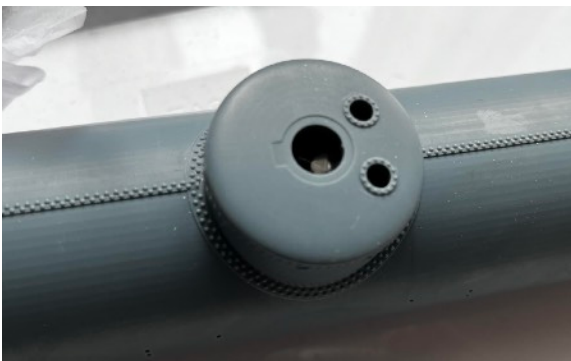

raw tank body

Preparation

I recommend to give the tank body and the car ends a good wet sanding with a 320 grit or finer for the best possible finish. Avoid rivet detail. The extra work will pay off. Do not dry-sand due to resin particles in the air.



smooth finish

Frame Preparation

insert the brass bar into the frame. It serves as a stiffener, weight and stress absorber. You should now decide what trucks you want to use for the car. An excellent choice is Protocraft trucks for which the car bolster was designed. We are working on National B's that will be available through 3D Central in the future.

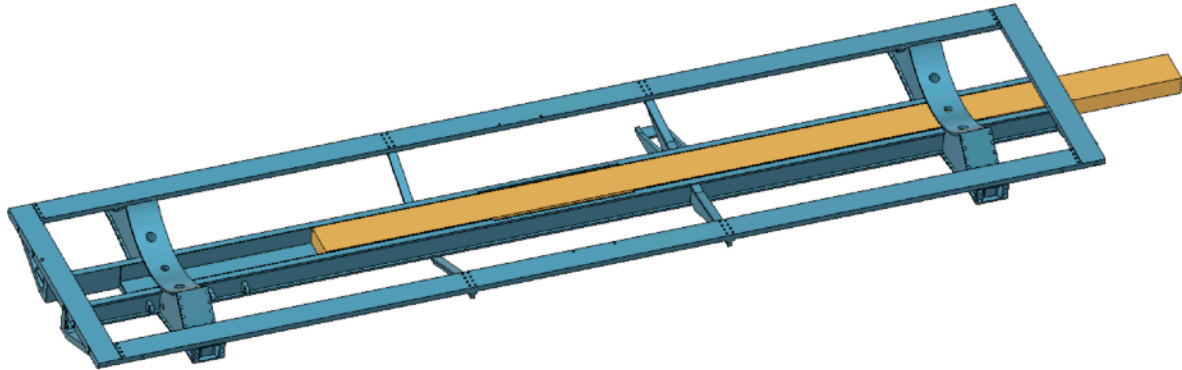

Mark, drill and tap the holes into the brass bar for the truck screws. Make sure the brass bar sits perfectly centered with no overhang where the coupler draft gear boxes will be located later. Test fit your trucks. There's nothing more annoying than fiddling with these steps when the car is fully detailed. Protocraft's truck mounting screw is an M2.

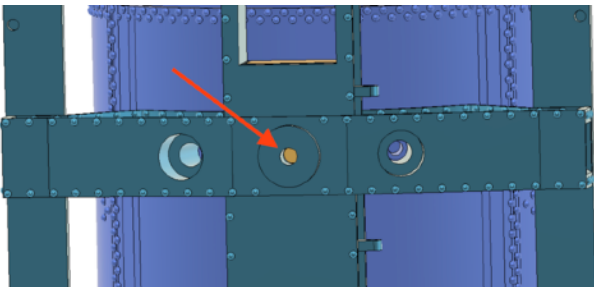

Test Fit The Parts

Make sure you get a good connection between tank body and frame. Inspect the two screw holes in each car bolster and that they align with the pre drilled parts of the tank body. You may have to widen those to accept the four mounting screws. Tapping recommended. **Do this now, later on, when the car is fully detailed, this will be a real pain.** With the car ends open you have more control, too. You can then glue the brass bar in place into the frame. Make sure your truck pin mounting holes align. I use 2K Epoxy glue for this connection.

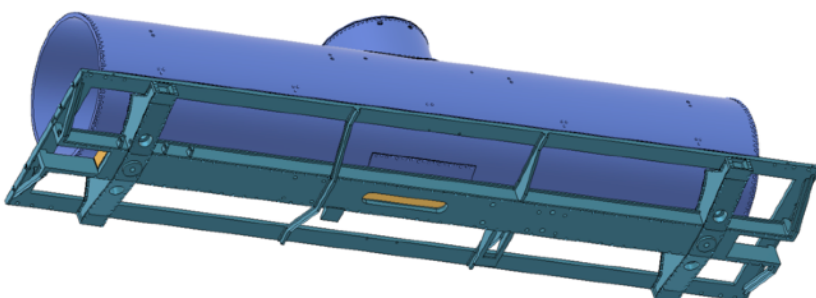

Tank

Glue tank ends, dome hatch and safety valves in place. A slow CA might be the ideal choice for most connections on this model. **DO NOT GLUE** the handrail stanchions into the tank ends yet! You'll need to be able insert the handrail later. Also glue the step board mounting brackets in place.

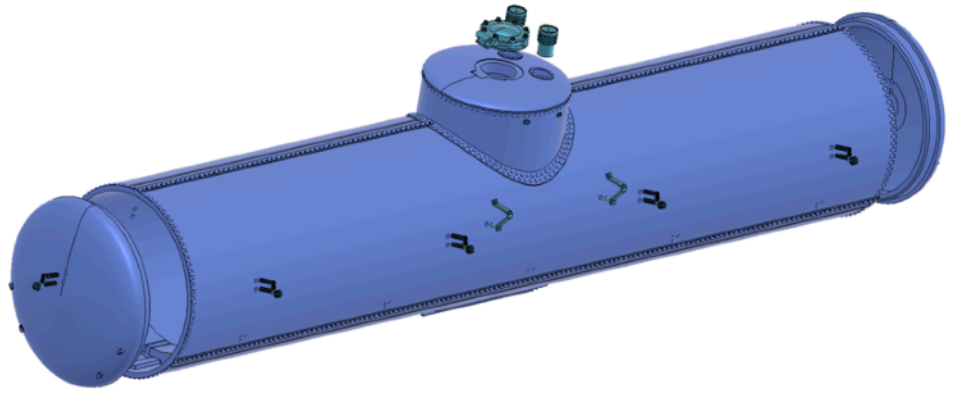

Make grab irons for the car ends and on each side of dome from 0.8mm brass wire. The dome grabs follow the round shape of the turret on a slight curve. The holes are pre-drilled and require some cleaning with a drill bit.



Use the bending jig to fabricate the handrail ends from 1mm brass rod. I recommend two sets of handrails that meet exactly in the middle of the car. You might have to do the bending around some rounded object and frequently come back and check with the bending jig.

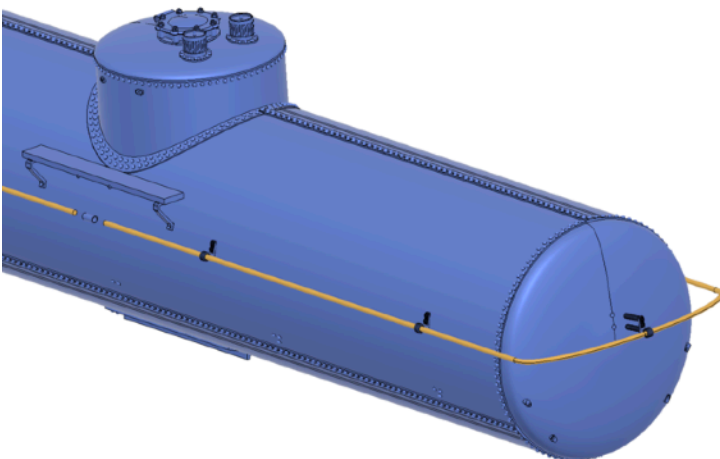
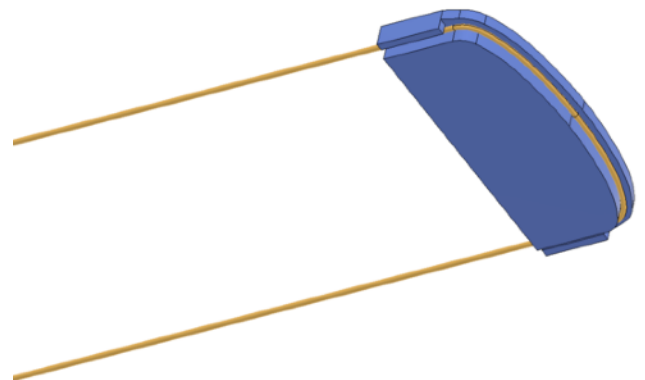

Once satisfied with the shape, place one loose handrail stanchion in the middle and insert your handrail into the tank's stanchions. You might want to ease this process by filing down the sharp edges of your brass handrail. Be careful. You can connect the two sections of handrail with the printed tubing in your kit. **Do not confuse these with your turnbuckles.** I recommend to install the step board after painting.

Couplers

With the tank prepared we can now detail the underframe. Now it is time to choose which couplers you wish to use. The kit has parts for both Protocraft and Kadee couplers. Both products share the top of the draft gear box. Slide the top part in place. **Do not use force. Sand the sides as needed.**

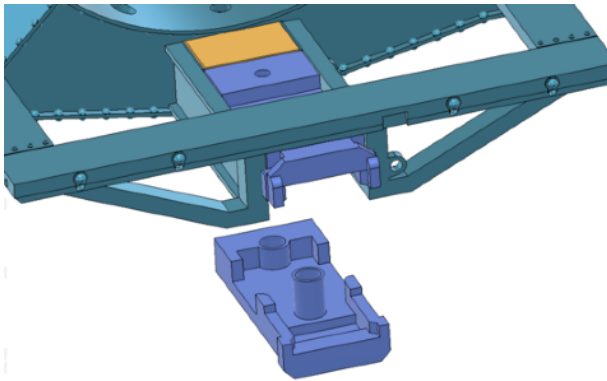
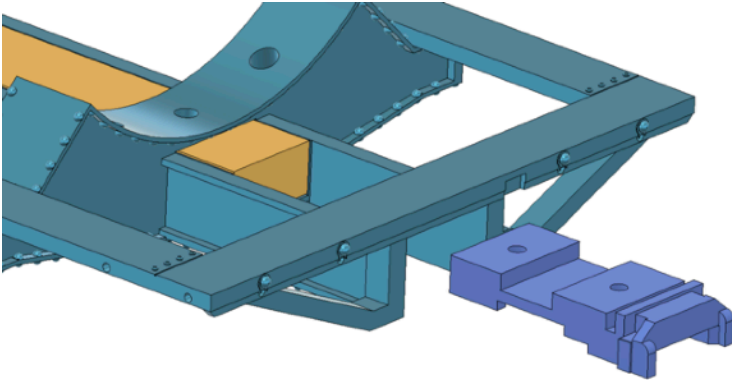

Kadee

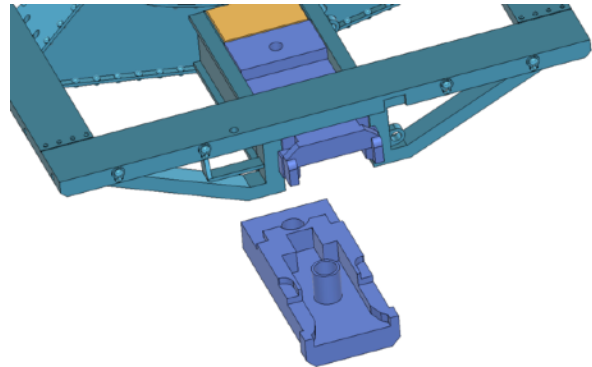

Protocraft

Test fit the coupler height with your trucks in place on a piece of track. Please do it, I know you don't want to but you'll thank me later.

When everything looks good, glue the top part of the draft gear box in place with 2K epoxy or CA, make sure you don't spill any glue to parts where later the coupler needs to move freely. You can mount the lower part of the draft gear box in place with two screws that are not included in the kit. Sorry. Do that later after painting.

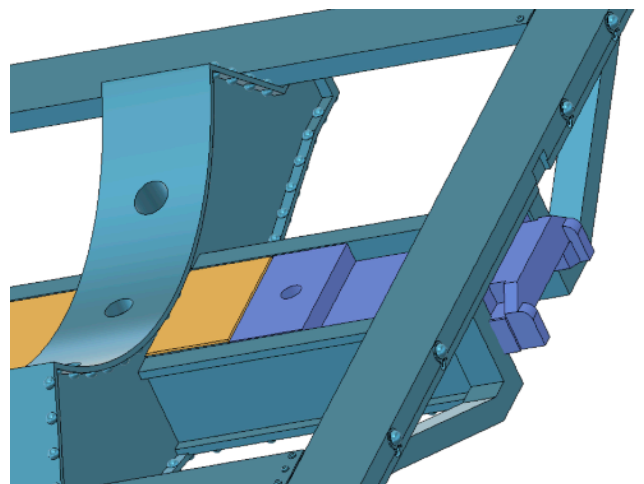

Air Line

Use 1mm brass rod to form your air lines, one for each end. When inserting the brass trough the mounting brackets, make sure they are completely open and wide enough. You can use a drill bit in a pin vise, 1.1mm would be ideal. Also smooth down sharp edges on your brass rod.

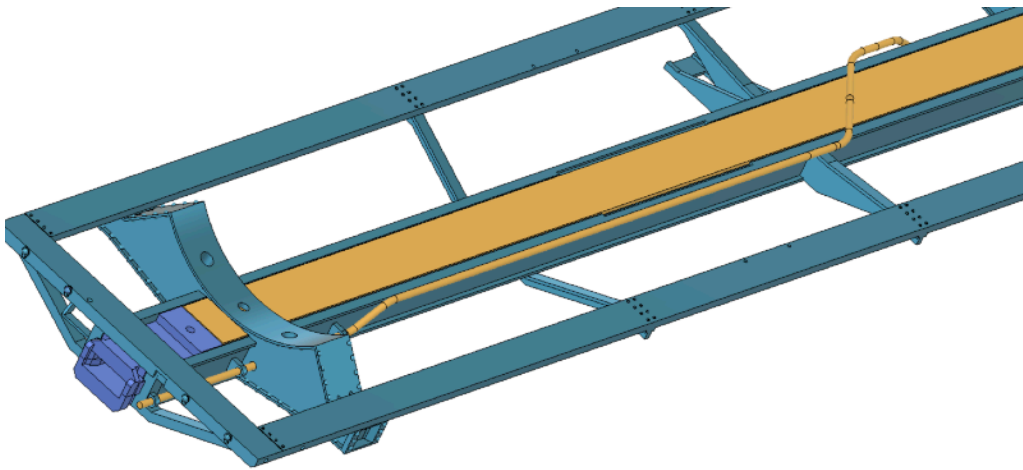
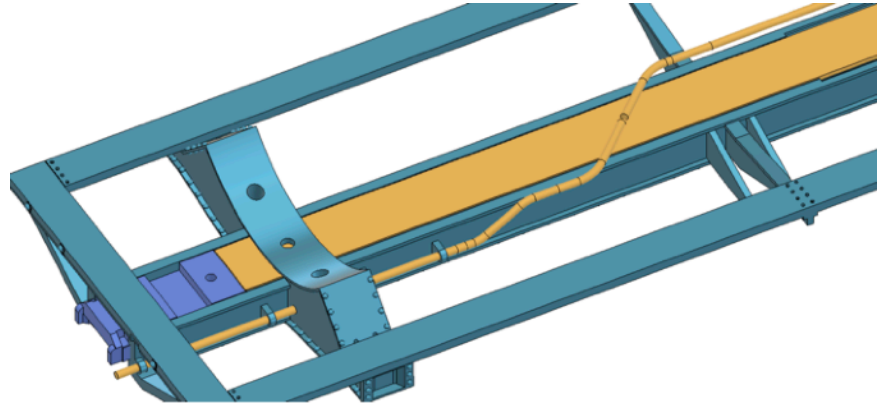

Do not break these delicate brackets. start from the car center towards the ends. Bend your shape before inserting the brass. It will look terrific! Do not yet mount the angle cocks, do that later and handling the model will be much easier.

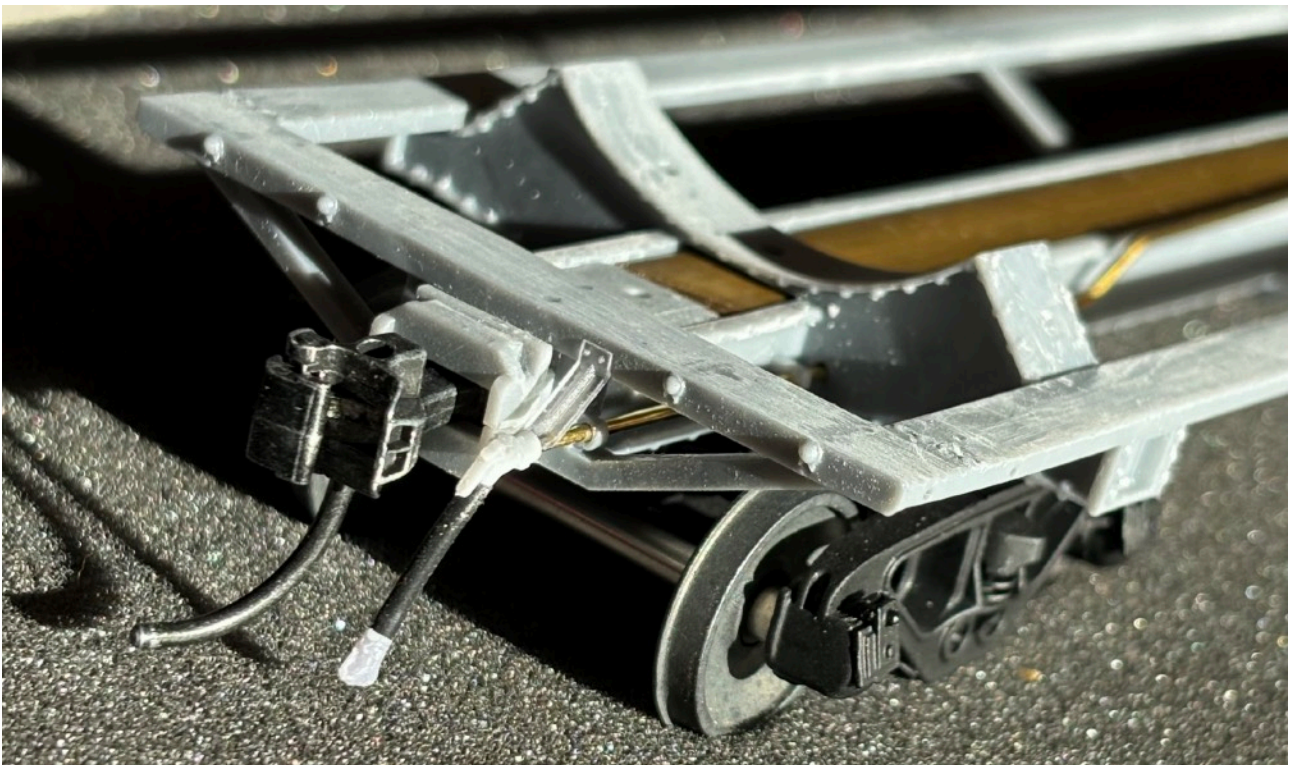

Angle cock test fit to determine air line length

Before you mount all the underbody detail, it is time to add the grab irons. You'll need to bend 4 on the car ends and 4 on the car sides. I use 0.8mm brass wire for this. The holes are pre drilled but need some cleaning with a drill bit. Also notice how your car parts are much cleaner prints than my home printed sample car here.

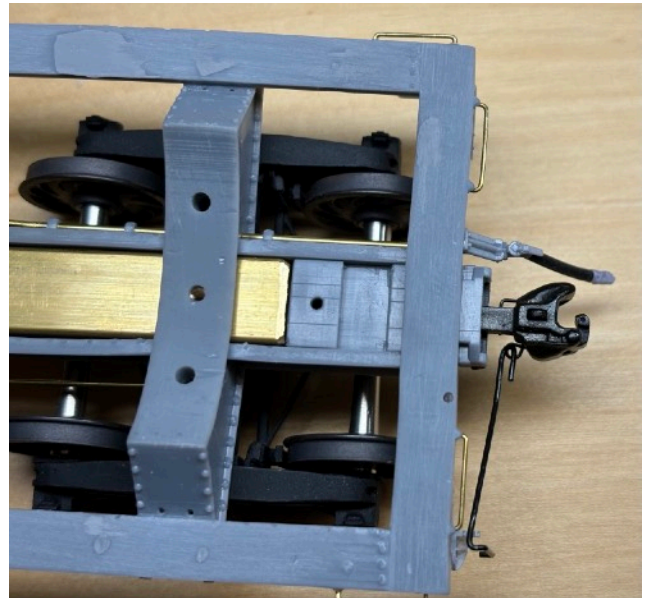

Time to add all remaining underbody components and brake gear. Take your time to test fit all components. The brake fulcrums are optimized for 0.8mm brass wire. Air reservoir orientation. It is good practice to glue the parts in place once the brass air

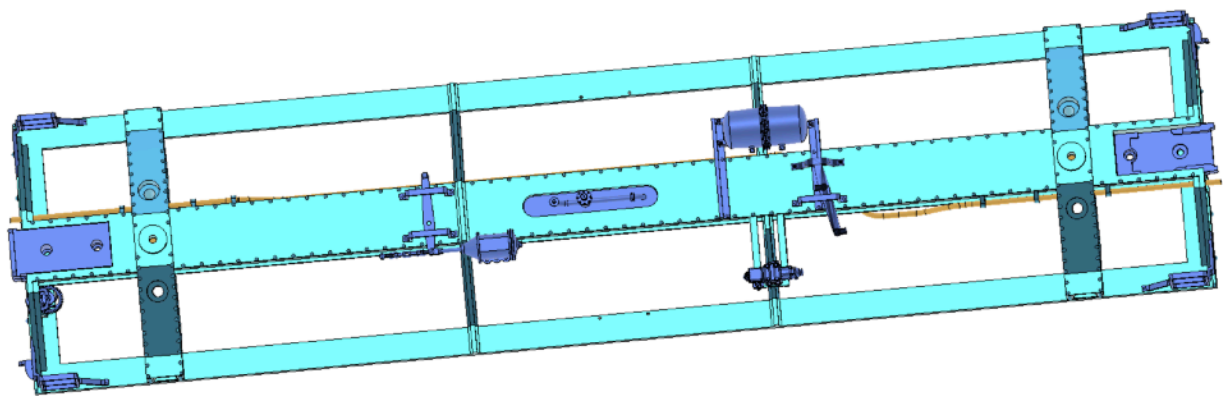

connections have been manufactured. I use 0.5mm brass rod for those fine lines. be sure to connect one line between brake cylinder and brake valve.

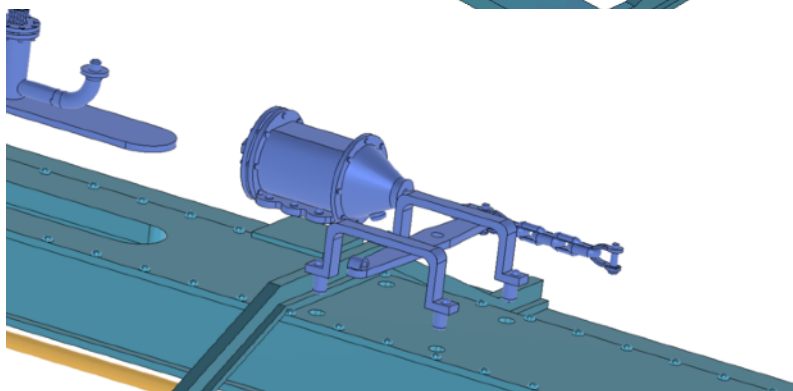
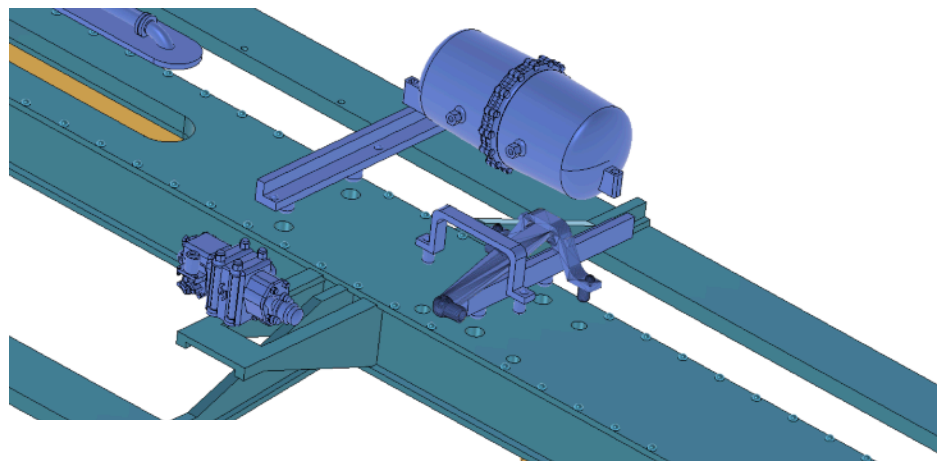

Tank drainage orientation

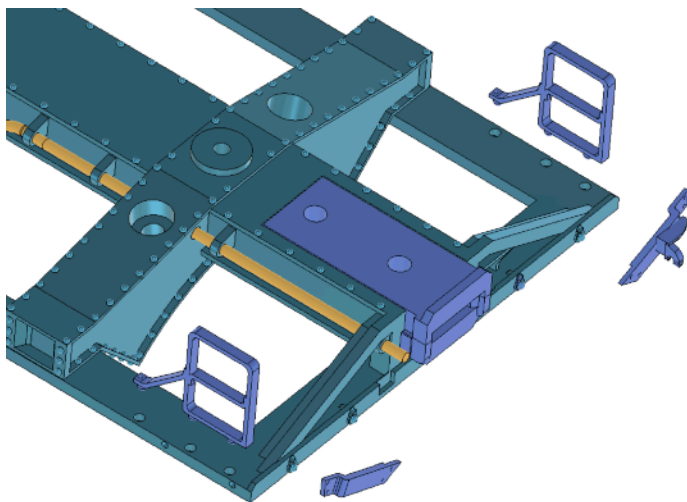
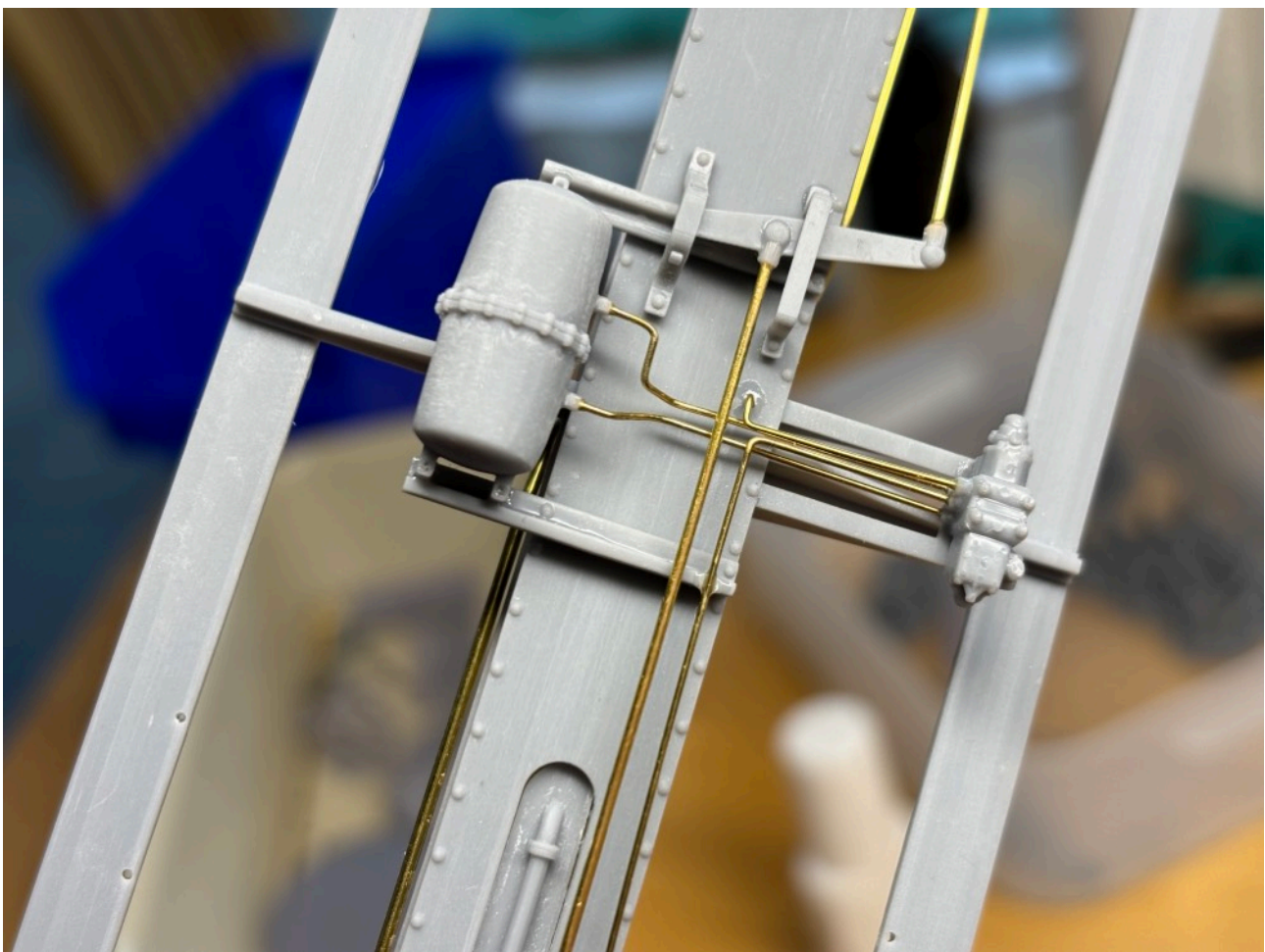

Also mount the stirrup steps. All parts have pre drilled holes. Make sure the stirrups are nice and square before gluing the diagonal straps. **Study orientation of these before using your CA.**

Handling of the car is getting more difficult now. Be careful with placing the frame on the stirrups, rather use the upper side to rest the model for now.

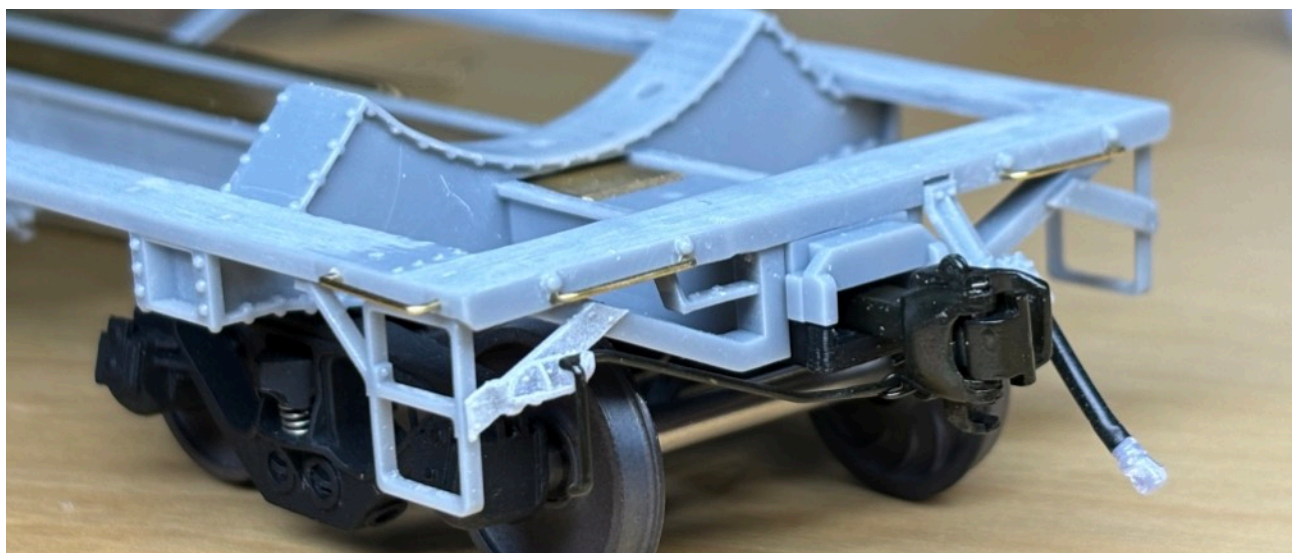

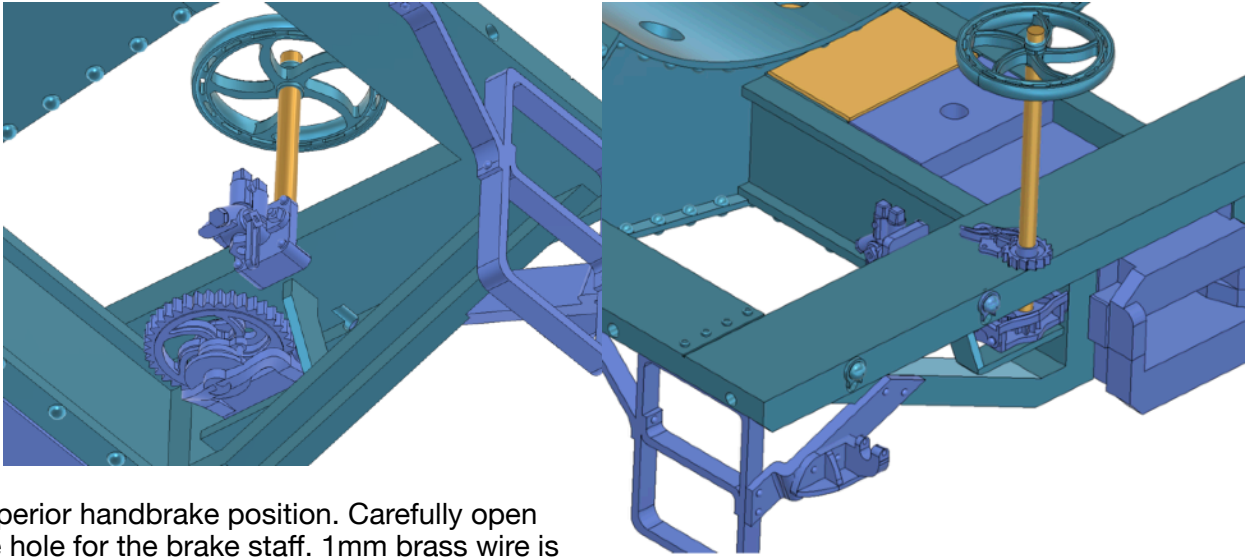

Superior handbrake position. Carefully open the hole for the brake staff. 1mm brass wire is a good choice. You might want to finally install the hand wheel and staff after completion of the model. The Westinghouse Dual-Pressure Retaining Valve's position is exactly where shown on the 3D pictures above.



The handbrake is very filigrane and easy to break. Be sure to carefully pre-drill.

Let's not forget to glue the angle cocks in place.

I use Precision Scale Co. Part #48388 rubber

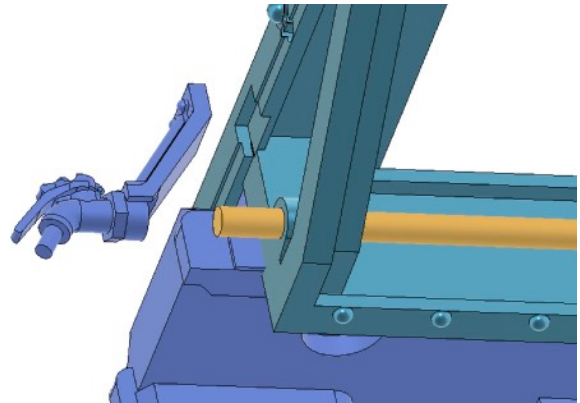

hose between glad hands and angle cocks.

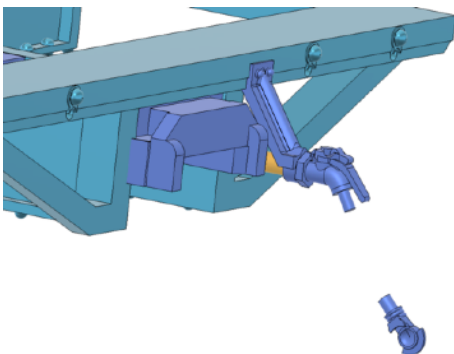

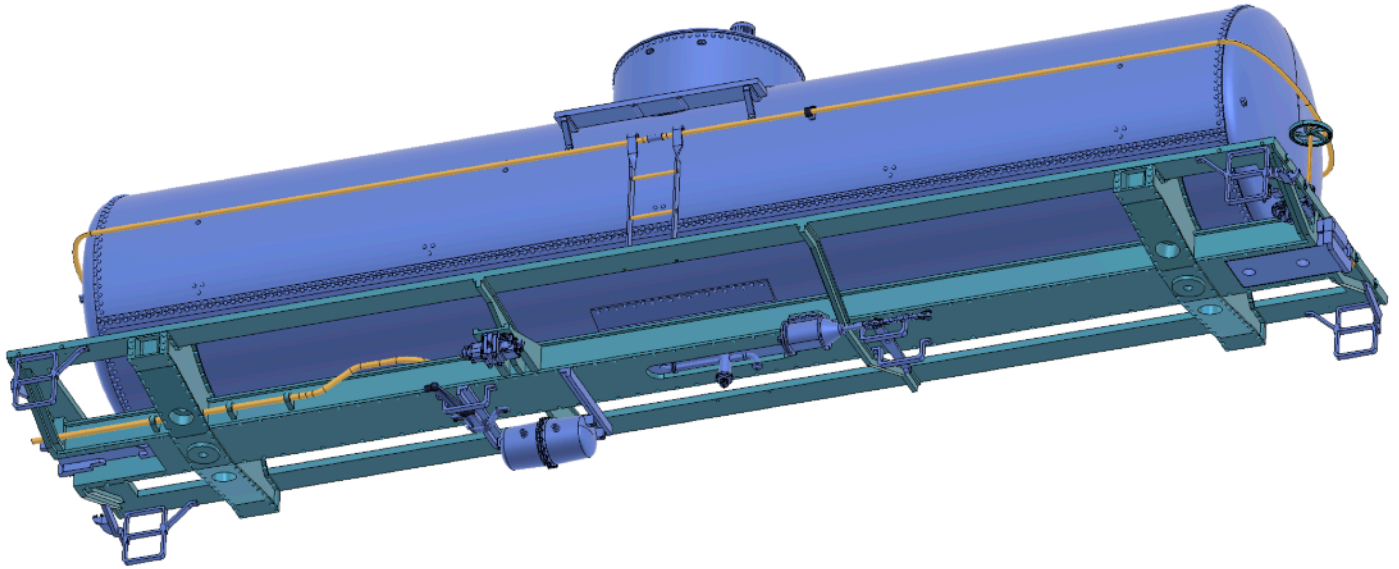

Ladders

Now is a good moment to build these. be sure to use the two pre drilled holes in your running boards to measure the ladder's width. 0.8mm brass wire make the perfect rungs. I would only mount the ladders in place after full assembly of the car. They can then be secured with brass wire bolts.

The running board has a certain amount of flexibility. When you glue and bolt the ladders, you do not want to lift the car right there. **THE BEST WAY TO HANDLE THE CAR IS AT THE BOLSTERS.**

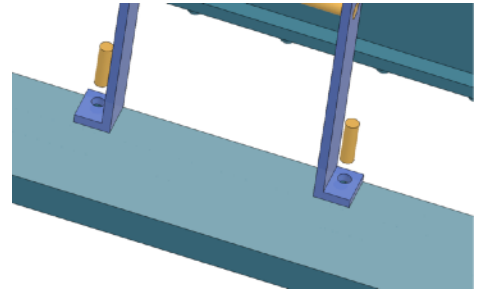

Tank straps

Evergreen item #123 styrene strips, 0.5 x 1.5mm make for a good choice here. The turnbuckles are designed for 0.8mm wire. Pre-drilled holes in the car bolster have to be cleaned out with a drill bit. It is a bit tricky to find the right length for the straps. Mounting the tank body to the frame temporarily will help with that. You might consider to only mildly glue the turnbuckles down to be able to de-assemble the tank one day. I separately painted straps, tank, ladders and frame.

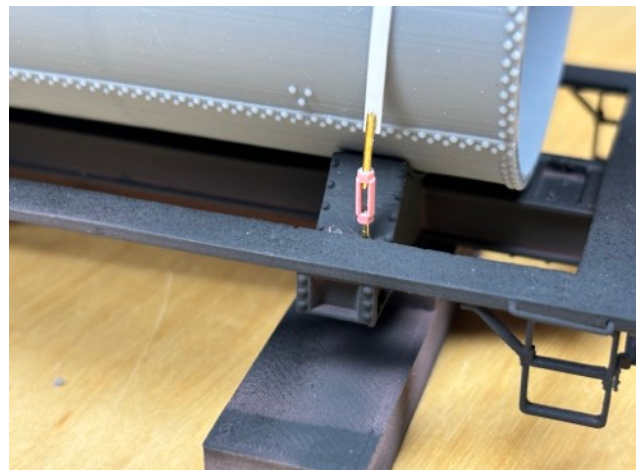

Painting

You might want to degrease your model with water and a bit of dish soap. Rinse, let completely dry. I use Tamiya primer on all printed resin parts with great success. It gives the paint a great base to stick and seals the UV resin. As you can see, I've installed my handrail after painting but I will not do that with the next cars. I painted my prototype with Tamiya spray can paint but will switch to TrueColor in the future.

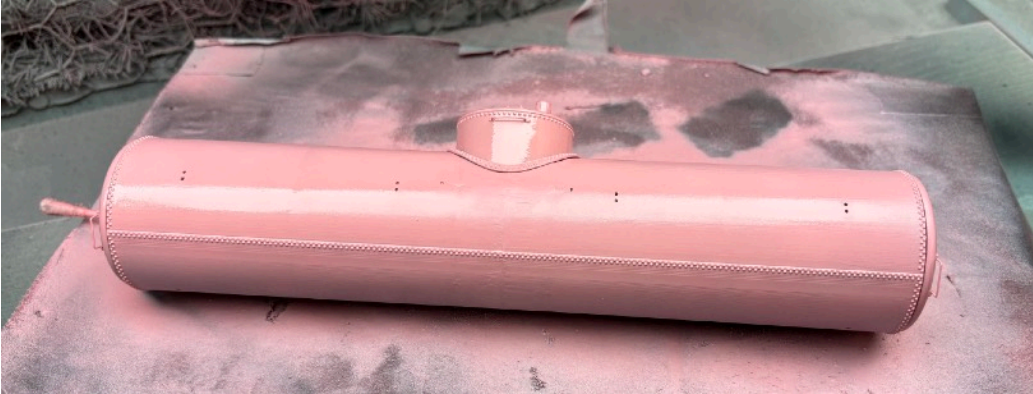

Parts

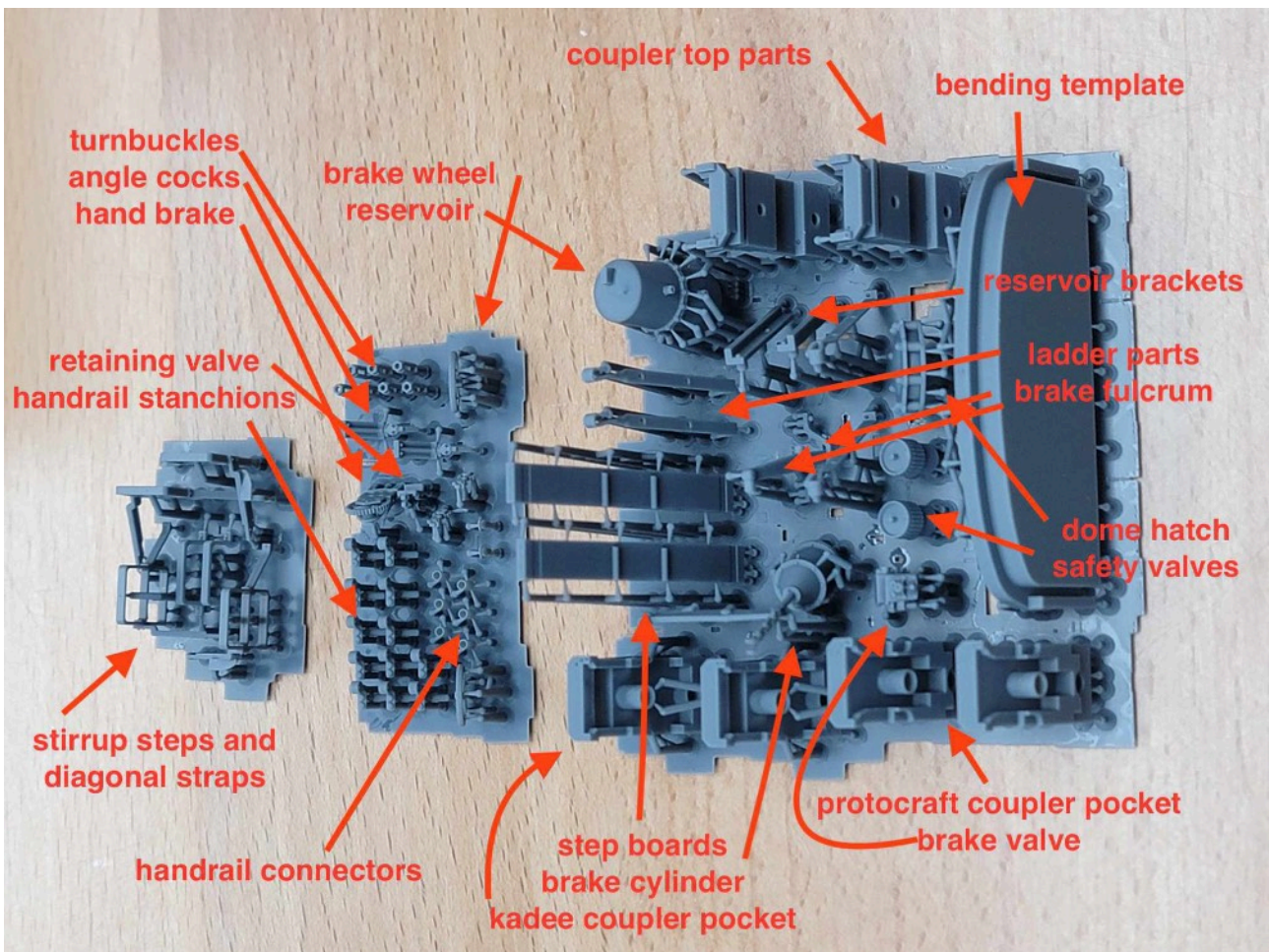



I hope you enjoyed the build - please let me see your cars! Do not hesitate to contact me via my website www.trainkitchen.com