



espresso coffee machines



MANUAL FOR USE AND MAINTENANCE

CS1

WEEE

Disposal of equipment by the users in the territory of the European Union (WEEE), according to standards 2011/65/UE, 2012/19/UE and 2015/863/UE, relating to the reduction of the use of dangerous substances in electrical and electronic equipment, as well as waste disposal.

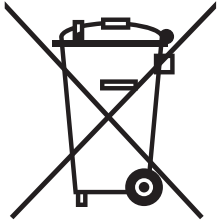

The symbol of the crossed waste bin indicated on the equipment or on the packaging means that the product at the end of its lifetime must be disposed of separately from all the other waste.

The separate collection of this equipment coming at the end of its lifetime is organized and run by the importer/distributor. The user who should have to dispose of such equipment should get in touch with the importer/ distributor and follow the procedure they have adopted for the separate disposal of the equipment coming at the end of its lifetime.

The proper separate disposal of disused equipment so that it can be recycled and treated according what is environmentally compatible contributes to avoid possible negative effects on the Environment and on Health and allows the reutilization and/or the recycling of the materials the equipment is composed of.

The improper disposal by the user causes the enforcement of the administrative sanctions according to current regulations.

GENERAL WARNINGS FOR THE INSTALLER

Read carefully the instructions and warnings contained in this manual and in the “INSTRUCTION MANUAL FOR THE INSTALLER” since they provide important indications concerning the installation of the appliance.



Attention!

The electric system, water supply system, drainage system **MUST** already be put in place by the customer in order to allow the proper installation of the machine. The installation engineer cannot change the existing system put in place by the customer. See chapter “INSTALLATION REQUIREMENTS FOR THE USER”.



Attention!

The appliance must be installed where use and maintenance are restricted to trained staff.

SAFETY NORMS



Attention!

CAREFULLY READ THE FOLLOWING WARNINGS, WHICH OFFER IMPORTANT GUIDELINES FOR THE SAFE USE AND MAINTENANCE OF THE APPLIANCE.

The appliance must only be used for its intended purpose and it must be installed in a suitable place for its use. Any other use is therefore considered as improper and unreasonable.

The manufacturer cannot be held liable for any damage caused by improper, incorrect or unreasonable use. Installation must be carried out by qualified personnel according to current laws and to the manufacturer's instructions. Incorrect installation may cause damage to people, animals or property for which the manufacturer cannot be held liable.



Danger!

The electrical safety of the appliance is fully achieved only after it has been correctly connected to an earthing system as required by the laws in force.

It is necessary to have the earthing connection checked by professionally qualified personnel. The manufacturer cannot be held liable for any damage caused by the lack or inefficiency of the system's earthing connection. The appliance has not been designed for outdoor use. It must only be operated in a place where the ambient temperature is between +5°C and +40°C.



Attention!

The use of any electrical appliance also requires observance of the following important regulations.

- Do not touch the appliance with wet or damp hands or feet.
- Do not use the appliance barefooted.
- Do not pull the power supply cord to unplug the appliance from the mains power.
- Do not children or unqualified people to use the appliance
- Access to the appliance's service area must be restricted to those people with the relevant practical experience and

familiarity with the appliance itself, especially in terms of safety and hygiene.

- This appliance is not intended for use by persons (including children) with reduced physical, sensory or mental capabilities or lack of experience and knowledge, unless they have been given supervision or instruction concerning use of the appliance by a person responsible for their safety. Children should be supervised to ensure that they do not play with the appliance.
- Before carrying out any routine maintenance or cleaning operation, disconnect the appliance from the mains power and close the water supply tap.
- In case of damage and/or malfunction of the appliance, switch it off completely without trying to make any direct repairs. Contact the nearest Service Centre authorized by the manufacturer.
- In order to guarantee the proper efficiency and operation of the appliance, it is important to follow the manufacturer's instructions, and to follow a regular maintenance schedule.
- The appliance has **IPX2** protection against water and therefore, it cannot be installed in areas where it may be subject to jets of water.
- The appliance has **class I** protection against electric shocks.
- The noise emitted by the appliance during normal operation is less than **70 dB**.
- The machine must be installed at a maximum height of 8000 meters
- Children do not play with the appliance.
- The maintenance and cleaning of the machine must not be carried out by unsupervised children.
- These instructions are also available in an alternative format, for example on the website



Attention!

Failure to comply with the above regulations could jeopardise the correct operation and safety of the appliance as well as its useful lifetime.

INSTALLATION REQUIREMENTS FOR THE USER

The appliance must be placed on a flat and stable surface and a surface height for the appliance of no less than 1.2 metres from the ground. Check this important requirement, since the manufacturer cannot be considered liable for any damage caused by the instability of the appliance. While preparing the system, take into account that a hole is needed on the bearing surface in order to carry out all electric and water connections through the opening below where a water softener will need to be placed, if recommended by the installation engineer. A hole of 10 x 10 cm is enough in the area (a) as indicated in Pict. 7.

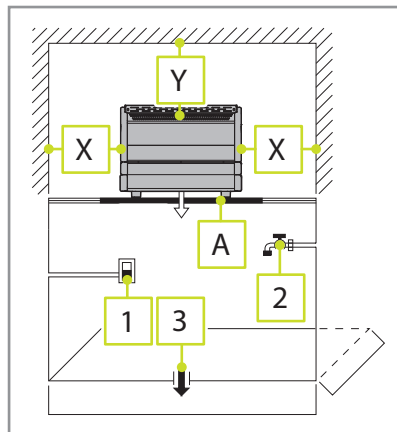

Legend:

- 1 Multi-pole power switch with a switch-contact gap of at least 3 mm
- 2 Water supply tap
- 3 Drain siphon
- X min. 20 cm.
- Y min. 40 cm.
- Z* min. 10 cm.

*) Distance between the back of the appliance and the wall.

The minimum size of the opening below is:

- height 60 cm
- width 40 cm
- depth 40 cm



INDEX

WEEE.....	II	5. SWITCHING ON THE MACHINE.....	12
GENERAL WARNINGS FOR THE INSTALLER.....	III	5.1 FILLING THE BOILER.....	12
SAFETY NORMS.....	III	5.2 SWITCHING ON THE APPLIANCE.....	12
INSTALLATION REQUIREMENTS FOR THE USER.....	VI	5.4 COFFEE PREPARATION.....	14
MINIMUM SIZE OF THE OPENING BELOW IS.....	VI	5.5 TAKING HOT WATER FOR INFUSIONS.....	14
TECHNICAL DATA.....	2	5.6 STEAM DELIVERY FOR HOT DRINK PREPARATION.....	15
1. GENERAL DESCRIPTION OF THE MACHINE.....	3	5.7 ELECTRIC CUP WARMER (OPTIONAL).....	15
1.1 CONTROL PANEL DESCRIPTION.....	8	5.8 UP FUNCTION (NOT AVAILABLE IN THE COMPACT LINE).....	16
2. WARNING AND TECHNICAL DATA LABELS AND PLATES APPLIED TO THE MACHINE.....	9	5.9 AUTOMATIC SYSTEM FOR MILK EMULSION WITH ADJUSTABLE TEMPERATURE-MAT (OPTIONAL).....	16
3. REMOVING THE PACKAGING.....	10	5.10 ALARM MANAGEMENT.....	17
3.1 STANDARD OUTFIT OF THE MACHINE.....	10	5.11 ALARM MANAGEMENT FOR COMPACT EK SERIES.....	19
3.2 OPTIONAL ACCESSORIES (SUPPLIED ONLY ON REQUEST OF THE CUSTOMER).....	11	6. ROUTINE APPLIANCE MAINTENANCE TO BE PERFORMED BY THE USER.....	20
4. STARTING THE SYSTEM.....	11	6.1 DAILY AT THE END OF THE JOB.....	20
		6.2 EVERY 3 DAYS.....	21

TECHNICAL DATA

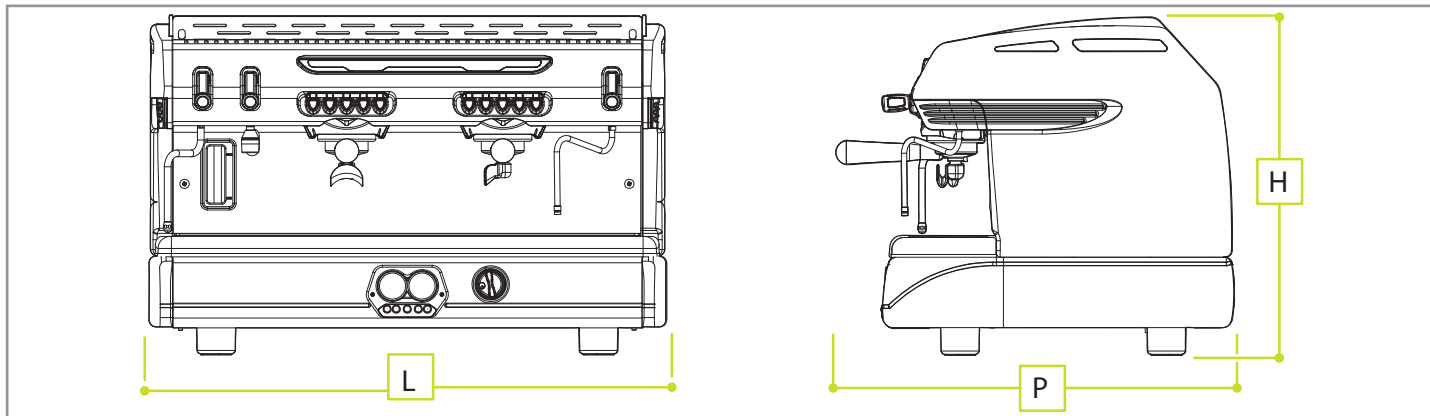

	MODEL						
	2 GR	2 GR TAKE AWAY	3 GR	3 GR TAKE AWAY	4 GR	4 GR TAKE AWAY	COMPACT
L	770	770	1000	1000	1235	1235	580
H	520	600	520	600	520	600	520
P	530	530	530	530	530	530	530
KG	65	70	80	86	97	104	54
VOLT	220/240/400		220/240/400		220/240/400		200/220/240
Hz	50/60		50/60		50/60		50/60
W	4100		6500		6500		3000
W+	-		-		-		3800

The symbol "W +" refers to the power of the machine' s power with upgraded heating element

1. GENERAL DESCRIPTION OF THE MACHINE

CS1

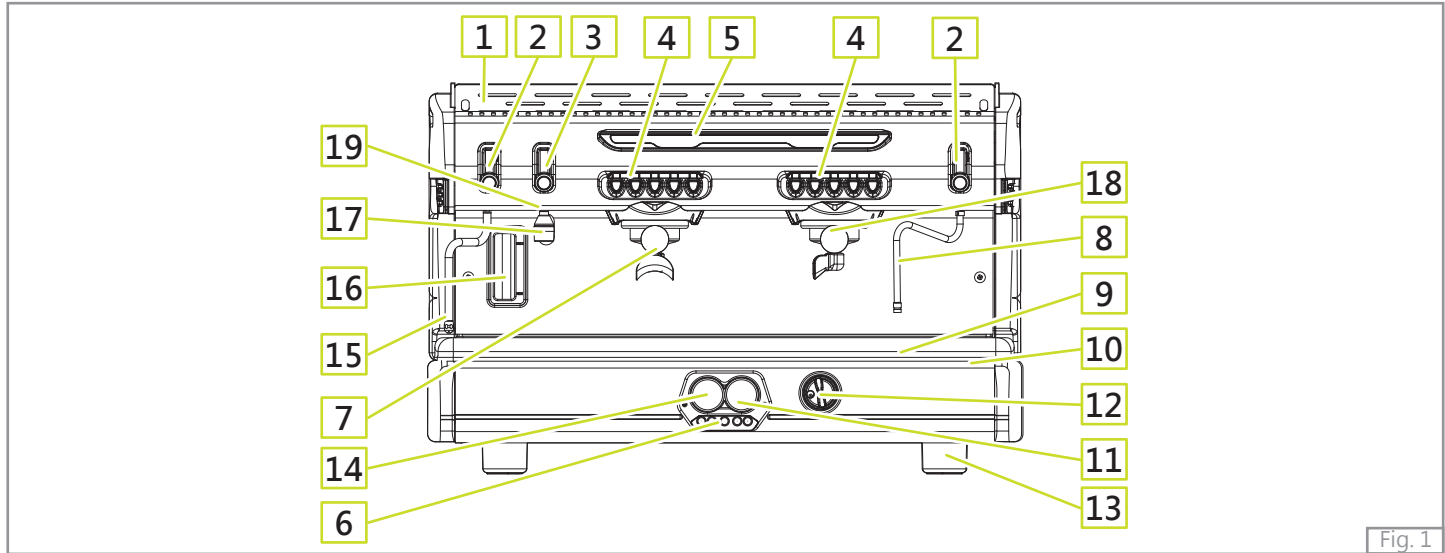

Fig. 1

LEGEND

- | | | |
|----------------------|---------------------------|-------------------------|
| 1. Top cup grid | 7. 2-cup portafilter | 14. Water mains gauge |
| 2. Steam tap | 8. Right steam wand | 15. Left steam wand |
| 3. Hot water tap | 7. Drip tray grid | 16. Water level glass |
| 4. Touchpad | 10. Water drip tray | 17. Hot water output |
| 5. Led light display | 11. Boiler pressure gauge | 18. One-cup portafilter |
| 6. Control panel | 12. Main on/off switch | 19. Filling valve |
| | 13. Adjustable foot | |

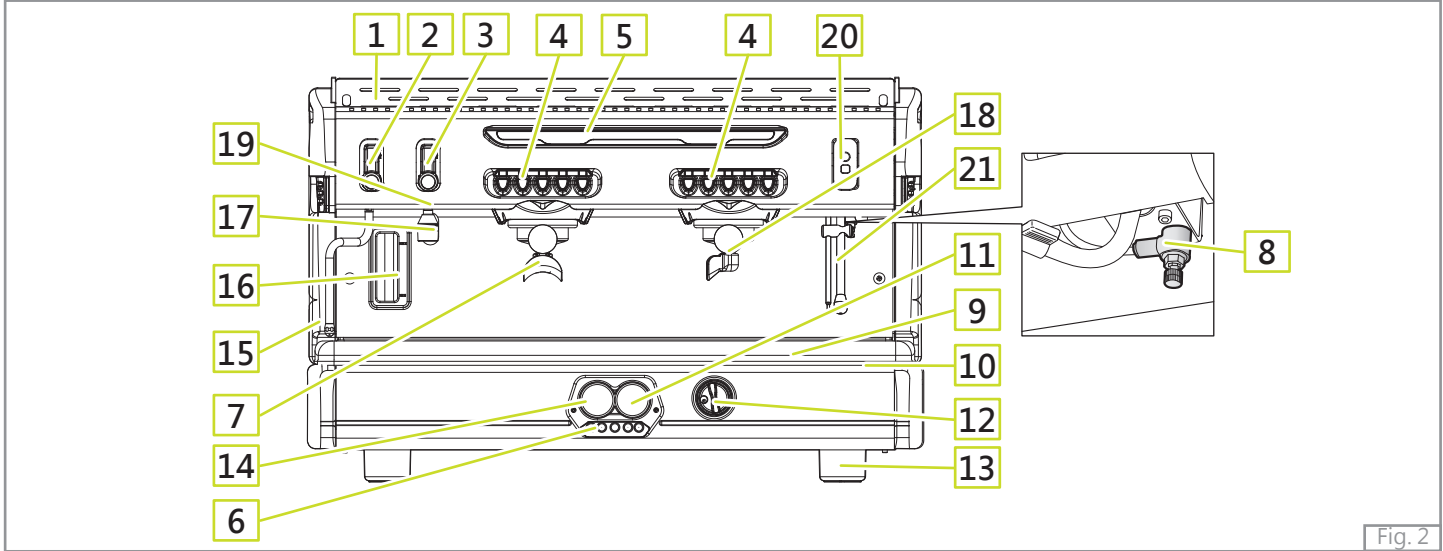

Fig. 2

LEGEND

- | | | |
|--|---------------------------|---|
| 1. Top cup grid | 9. Drip tray grid | 17. Hot water output |
| 2. Steam tap | 10. Water drip tray | 18. One-cup portafilter |
| 3. Hot water tap | 11. Boiler pressure gauge | 19. Filling valve |
| 4. Touchpad | 12. Main on/off switch | 20. Automatic steam delivery button
for milk foaming - M.A.T. (optional) |
| 5. Led light display | 13. Adjustable foot | 21. Steam wand with temperature sensor
- M.A.T. - (optional) |
| 6. Control panel | 14. Water mains gauge | |
| 7. 2-cup portafilter | 15. Left steam wand | |
| 8. Air adjustment for milk foaming
-M.A.T. (optional) | 16. Water level glass | |

CS1 AT

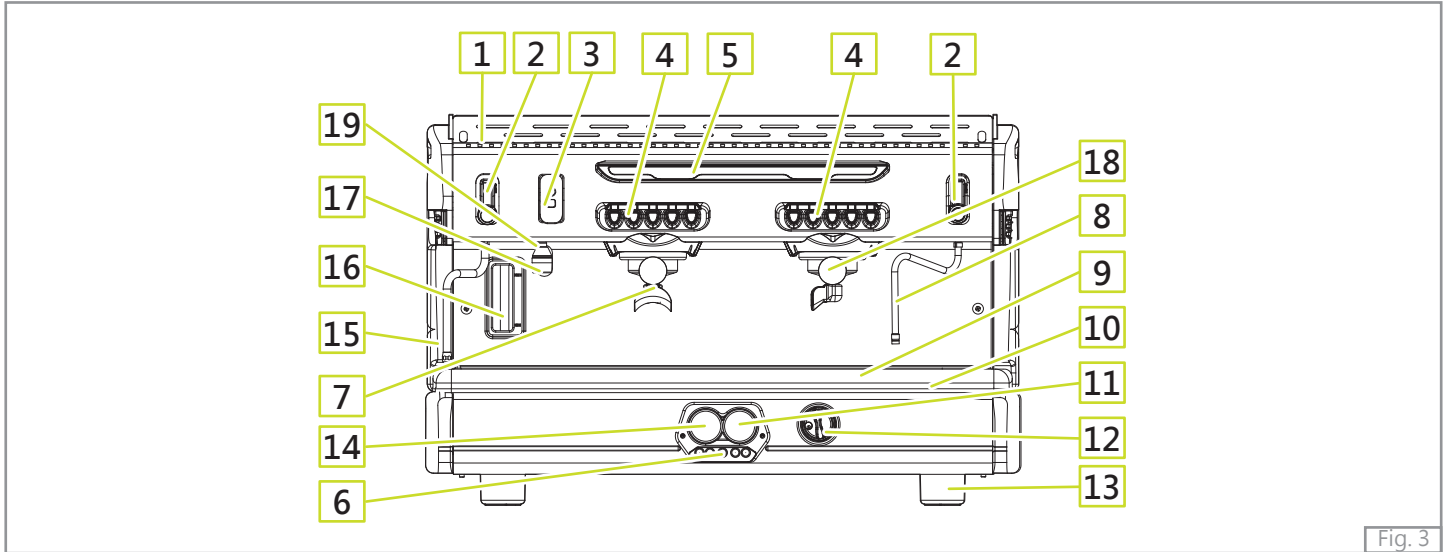

Fig. 3

LEGEND

- | | | |
|-------------------------------------|---------------------------|-------------------------|
| 1. Top cup grid | 7. 2-cup portafilter | 14. Water mains gauge |
| 2. Steam tap | 8. Right steam wand | 15. Left steam wand |
| 3. Preset hot water delivery button | 9. Drip tray grid | 16. Water level glass |
| 4. Touchpad | 10. Water drip tray | 17. Hot water output |
| 5. Led light display | 11. Boiler pressure gauge | 18. One-cup portafilter |
| 6. Control panel | 12. Main on/off switch | 19. Filling valve |
| | 13. Adjustable foot | |

CS1 TAKE AWAY

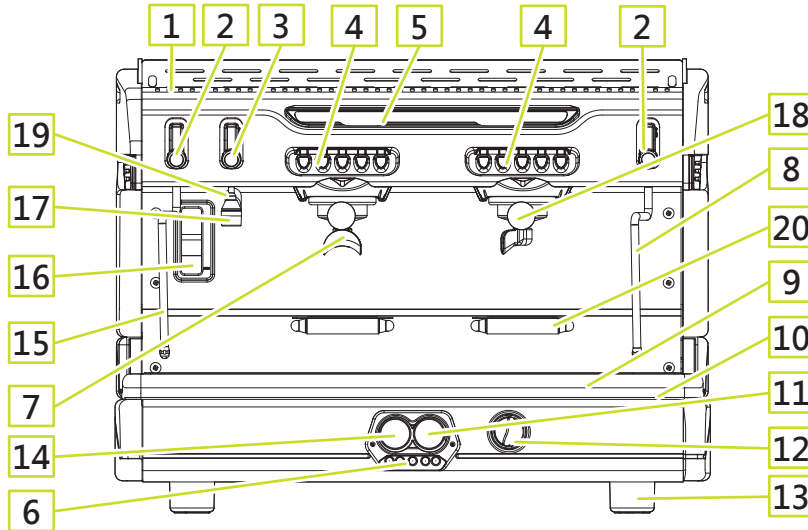

Fig. 4

LEGEND

- | | | |
|----------------------|---------------------------|-------------------------|
| 1. Top cup grid | 7. 2-cup portafilter | 14. Water mains gauge |
| 2. Steam tap | 8. Right steam wand | 15. Left steam wand |
| 3. Hot water tap | 9. Drip tray grid | 16. Water level glass |
| 4. Touchpad | 10. Water drip tray | 17. Hot water output |
| 5. Led light display | 11. Boiler pressure gauge | 18. One-cup portafilter |
| 6. Control panel | 12. Main on/off switch | 19. Filling valve |
| | 13. Adjustable foot | 20. Cup Grid |

CS1 COMPACT

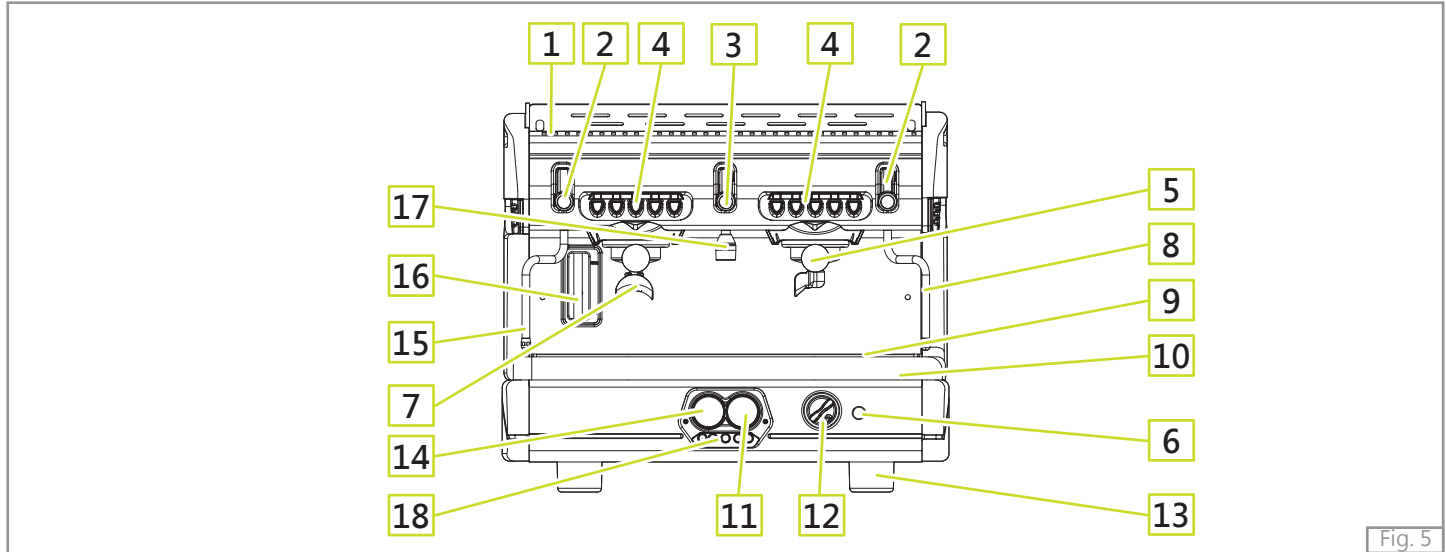
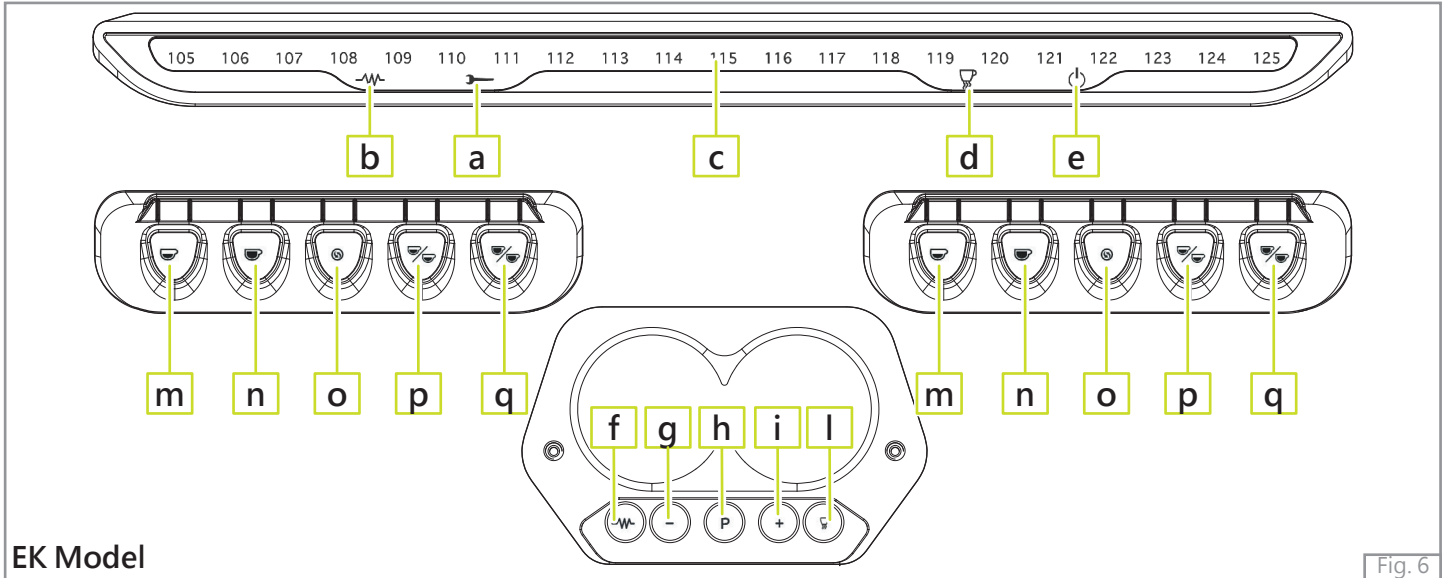

Fig. 5

LEGEND

- | | | |
|--|--|---|
| <ul style="list-style-type: none"> 1. Top cup grid 2. Steam tap 3. Hot water tap 4. Touchpad 5. One-cup portafilter | <ul style="list-style-type: none"> 6. Electric cup warmer button (optional) 7. 2-cup portafilter 8. Right steam wand 9. Drip tray grid 10. Water drip tray 11. Boiler pressure gauge | <ul style="list-style-type: none"> 12. Main on/off switch 13. Adjustable foot 14. Water mains gauge 15. Left steam wand 16. Water level glass 17. Hot water output 18. Control panel |
|--|--|---|

1.1 CONTROL PANEL DESCRIPTION



EK Model

Fig. 6

LEGEND

- a. Technical assistance indicator (optional)
- b. Indicator light for electric heating system status
- c. Temperature indicator lights
- d. Cup warmer heating element indicator light (optional)

- e. Stand/by indicator lights
- f. ON/OFF button for appliance electric heating
- g. Datum decrease button
- h. Datum confirmation button
- i. Datum increase button
- l. Cup warmer heating element activation button

- m. 1 short coffee preset delivery button
- n. 1 long coffee preset delivery button
- o. Continuous delivery key
- p. 2 short coffee preset delivery button
- q. 2 long coffee preset delivery button

2. WARNING AND TECHNICAL DATA LABELS

In the picture below are shown the warning/technical data labels and plates placed on the machine.



Attention!

Dedicate the time necessary to get to know these labels.

Make sure that they are readable and keep them clean or replace those that have deteriorated or have become illegible (both text and graphics). Use a soft cloth, soap and water to clean the labels.

Do not use solvents, petrol, etc.. If a label is placed on a component part that has to be replaced, make sure that the new component has the same label applied or a new one.

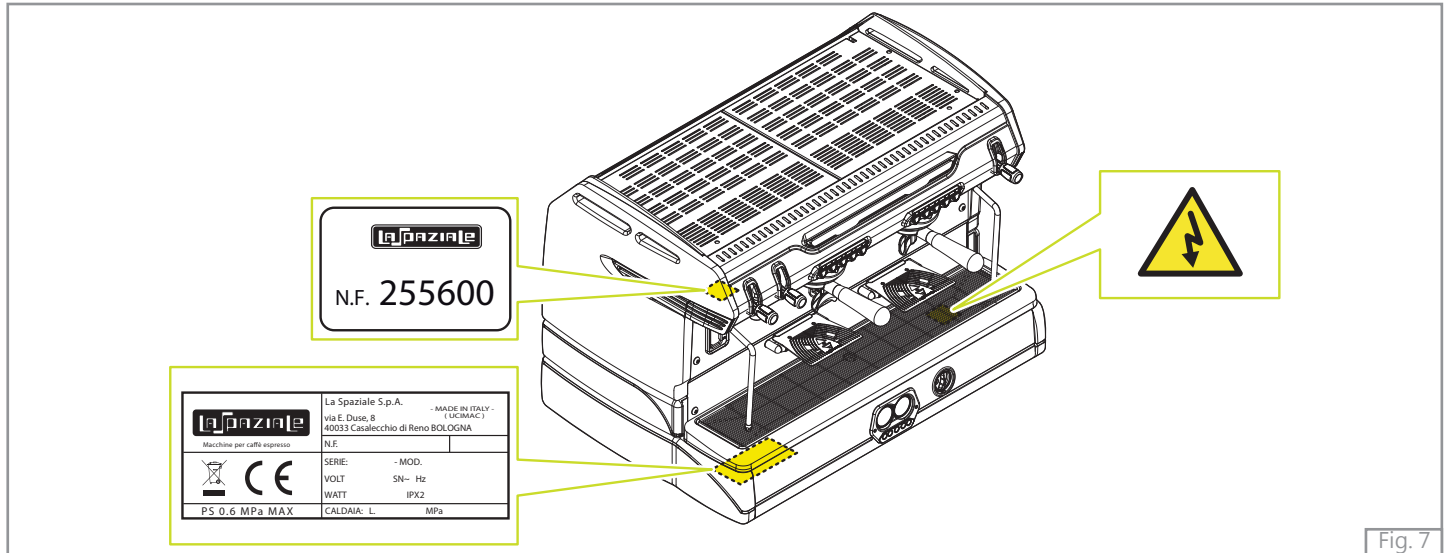

Fig. 7

3. REMOVING THE PACKAGING

After unpacking the machine, please check its integrity; in case of doubt, do not use it and consult the manufacturer. Packaging materials must not be left within children's reach since they are potentially dangerous.



Attention!

The appliance weight is more than 30 kg and therefore, it cannot be moved by a single person alone.



NOTE!

Dispose of the packaging elements in accordance with the regulations in force in the country where the machine is used.

3.1 STANDARD OUTFIT OF THE MACHINE

LEGEND

- A. 1 set of portafilters with relative spouts
- B. 1 complete set of hoses for connection to water mains
- C. 2 sets of filters
- D. 1 set of shower heads
- E. 1 wrench for shower head removal
- F. 1 brush
- G. 1 motor pump (excluding appliances where it is incorporated)
- H. 1 manual coffee tamper



3.2 OPTIONAL ACCESSORIES (supplied on request of the customer)

LEGEND

- I. Water softener
- L. Water line impurity filter
- M. Pressure reducer
- N. Detergent

4. STARTING THE SYSTEM

1. Open the water supply tap as arranged in the preparation for installation.
2. Check for any water leaks from the pipes/connections.
3. Turn on the main switch as arranged in the preparation for installation.

5. SWITCHING ON THE MACHINE

5.1 FILLING THE BOILER

- A. Open the water supply tap as arranged during the preparatory stages
- B. Verify that the water mains pressure (approx. 4 bars) is visualized on the water mains pressure gauge (14)
- C. Push the manual filling valve on the appliance (19) until the boiler level indicator is halfway (16)

In the COMPACT model, in order to have access to such tap, remove the drip tray (20); moreover, the tap closing is manual.

5.2 SWITCHING ON THE APPLIANCE

- A. Turn on the power supply switch that was prearranged during the system preparation and then, turn on the machine's main switch.
Once the machine is switched on, an electronic components check is carried through on 2-3-4 groups machines; all the symbols on the control panel, from left to right, are progressively turned on. At the end of this process, the symbol for the temperature setting will start to blink to indicate that the appliance is heating up.

In the Compact model, once the machine is switched on all the led lights of the touchpads turn on.



NOTE!

According to the amount of water filled manually, it is possible to activate the automatic refill system when the switch (12) is turned on, until the boiler water level indicated by the manufacturer is reached.

5.3 HEATING PHASE AND OPERATION SETTING OF THE APPLIANCE

- A. Fasten the portafilters to the delivery groups
- B. Open the steam delivery valves (more the lever upwards), then move the steam wands onto the grid
- C. wait for steam to come out of the wands and then, close the steam delivery knobs (moving the levers downwards).
- D. Wait for the machine to reach the operating temperature, which can be visualized on the boiler pressure gauge (11) positioned on the appliance on Compact series machine; on 2-3-4 groups machines check on the led lights display (5) for the operating temperature (expressed in °C) pre set at the moment of the installation, to be attained.
During the heating phase, make sure that the symbols on the control panel (6) switch on progressively as the temperature rises. The display will start to show this as soon as the temperature reaches 105° C and will continue until the appliance reaches its operating temperature (the set temperature symbol will go from flashing to fixed). Each time that the temperature drops below the preset value, the symbol indicating the operating temperature will start to flash (heating phase) until the set temperature is reached.
- E. The appliance is ready for use.



NOTE!

The operating temperature is the temperature of the boiler during normal operation.

5.4 COFFEE PREPARATION

- A. Remove a portafilter from the delivery group.
- B. Fill with ground coffee, taking care not to leave any coffee powder residues on the top edge of the portafilter, then press it using the special coffee tamper supplied.
- C. Attach the portafilter firmly.
- D. Place one or two cups below the portafilter.
- E. Press any of the coffee delivery buttons (**m-n-p-q**) with preset doses (set during installation) or, alternatively, use the free flow delivery button (**o**).



NOTE!

To stop coffee delivery earlier after using one of the buttons with preset doses, simply press again the same button on the same touchpad.

5.5 TAKING HOT WATER FOR INFUSIONS

- A. Place the pitcher underneath the hot water spout.
- B. Open the valve (3) by moving the lever upwards until the desired amount of water is withdrawn.
- C. In order to stop the withdrawal close the valve by bringing back the knob or the lever to the initial position.



Attention!

Do not use the knob to deliver hot water before placing the pitcher below the hot water spout, to prevent possible burns.

5.6 STEAM DELIVERY FOR HOT DRINK PREPARATION

- A. Insert the steam wand into the pitcher containing the drink to be heated up.
- B. Move the knob upward.
- C. At the end of the heating of the drink, shut the steam delivery by moving the knob downward.



Attention!

Do not turn the knob to deliver steam before inserting the steam wand into the pitcher in order to prevent possible burns.

5.7 ELECTRIC CUP WARMER (optional)

The appliances can also be equipped with an electric cup warmer (as optional) for an additional cup heating. To switch on the cup warmer, press the button (12). Press the same button to switch it off.

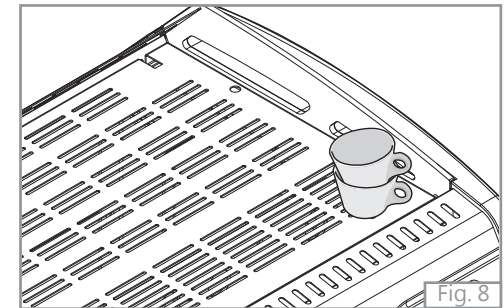

5.8 UP FUNCTION (not available in the Compact line)

When the machine is operated in conditions which may considerably reduce its temperature, the boiler temperature can be increased by 2°C by pressing the (i) button for approximately 5 seconds; by doing this, on the led display, the programmed SET temperature keeps blinking and at the same time the temperature symbol, 2°C higher with respect to the programmed SET, starts blinking as well (e.g. if the SET is 120°C, it blinks and keeps blinking, while the 122°C SET starts blinking as well).

The new SET will follow the temperature trend, flashing when the appliance is heating up and fixed when the set temperature has been reached.

To return to the initial status, press the button (g) for about 5 seconds.

5.9 AUTOMATIC SYSTEM FOR MILK EMULSION WITH ADJUSTABLE TEMPERATURE - M.A.T. (optional)

Appliances fitted with this system can foam milk in a completely automatic way.

- A. Insert the steam wand with temperature sensor into the pitcher of milk.
- B. Press the automatic steam delivery button for milk.
- C. The steam delivery will stop automatically as soon as the temperature set during installation has been reached.
- D. When the milk has been foamed, remove the pitcher and use a damp sponge to clean all milk residues from the steam wand with temperature sensor.



NOTE!

Do not press the automatic steam delivery button for milk foaming before inserting the steam wand with temperature sensor into the pitcher, in order to prevent possible burns.

5.10 ALARM MANAGEMENT

The machines of this series signal possible malfunctions through symbols on the control panel and touchpads.

1. LED CORRESPONDING TO THE COFFEE DOSE BEING delivered FLASHING AFTER 5-6 SECONDS:

Too fine grinding.

Failed reading of the pulses sent by the flow meter to the delivery group.

After checking grinding, if the problem continues, contact a Service Centre.

2. ALL DOSE SYMBOLS ON ALL TOUCHPADS FLASHING AND TEMPERATURE SYMBOLS SWITCHED OFF:

The automatic refill system for the boiler has been operating for longer than 3 minutes (total block of all machine functions).

To return to normal operation, turn off the machine with the ON/OFF switch (12). If the problem persists, switch off the appliance and contact a Service Centre.

3. "125 °C" SYMBOL ON AND BLINKING; ALL OTHER SYMBOLS SWITCHED OFF:

When the temperature taken by the sensor is above 140° C (total block of all machine functions).

To return to normal operation, turn off the machine with the ON/OFF switch (12). If the problem persists, switch off the appliance and contact a Service Centre.

4. "105 °C" SYMBOL BLINKING AND ALL OTHER SYMBOLS SWITCHED OFF:

When 20 minutes after switching on, the temperature taken by the sensor is less than 60° C (total block of all machine functions). To return to normal operation, turn off the machine with the ON/OFF switch (12). If the problem persists, switch off the appliance and contact a Service Centre.

5. ALL TEMPERATURE SYMBOLS FLASHING AND ALL TOUCHPAD SYMBOLS SWITCHED OFF:

Temperature sensor in short circuit or failure (total block of all machine functions).
Switch off the appliance and contact a Service Centre.

6. M.A.T. SYSTEM DELIVERY BUTTON SYMBOL SWITCHED OFF (only if present):

M.A.T. temperature probe short circuit or failure.
Contact a Service Centre.



NOTE!

When this alarm condition occurs, it is still possible to foam milk automatically by holding down the M.A.T. delivery button (20), until the required temperature is reached. When the button is released, steam delivery will stop.

7. TECHNICAL ASSISTANCE SYMBOL LIGHT ON

(only if SERVICE control has been set by the technical assistance):

This means the number of preset solenoid valve action cycles has reached the set alarm threshold.
Contact a Service Centre.



8. TECHNICAL ASSISTANCE SYMBOL LIGHT FLASHING

(only if FILTER control has been set by the technical assistance):

This means the number of pre-loaded litres for the softener has reached the set alarm threshold.
Contact a Service Centre.

5.11 ALARM MANAGEMENT FOR COMPACT EK SERIES

LED CORRESPONDING TO THE COFFEE DOSE BEING DELIVERED, FLASHING AFTER 5-6 SECONDS:

Too fine grinding.

Failed reading of the pulses sent by the flow meter to the delivery group.

ALL LEDS CORRESPONDING TO ALL DOSES ON ALL TOUCHPADS FLASHING:

The automatic filling function for the boiler tank has been operating for more than 4 minutes, total machine block. To return to the standard operating phase, switch the machine off using the main ON/OFF switch.

If the problem keeps occurring several times, verify the automatic boiler filling system.

6. ROUTINE APPLIANCE MAINTENANCE TO BE PERFORMED BY THE USER



NOTE!

To grant the efficiency of the appliance and to maintain correct operation, it is necessary to follow the manufacturer' s instruction as to cleaning and regular maintenance.



Attention!

Cleaning and routine maintenance operations must be carried out by the user according to the manufacturer' s instruzioni

6.1 DAILY AT THE END OF THE JOB

1) Replacing the water in the boiler.

After turning off the appliance,replace the water in the boiler as follows:

- Place a container that can withstand high temperatures below the hot water spout (17) to prevent any hot water spills
- Open, by rotating it anti-clockwise, move upwards the lever (3) up to the complete emptying of the boiler. Close the valve (3) and switch the machine back on. The correct water level gets restored automatically in the boiler.

2) Then clean the portafilters and the filters with the brush provided, making sure no dirt is left inside the portafilters and that all filter holes are clean.

3) Clean the shower heads below the delivery groups with the brush.

4) Clean the drip tray (10) and the cup grid (9), using the standard detergents available on the market, if necessary.



6.2 EVERY 3 DAYS

After turning off the machine, remove the shower heads using the wrench provided; brush them carefully, making sure that all the holes are clean. Then reassemble the parts following the sequence shown in the picture.

- A. Fastening screw
- B. Small shower head
- C. Large shower head
- D. Diffuser
- E. Delivery group

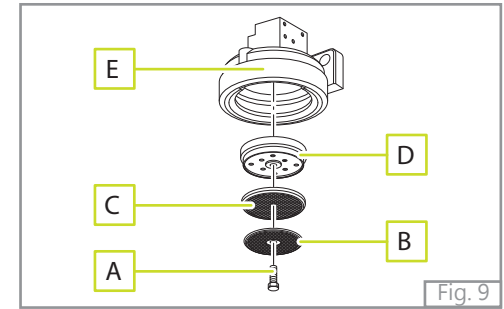

NOTE!

Do not use water jets to clean the machine.



Attention!

At the end of each workday and after performing the daily cleaning operations, deactivate the machine by closing the electrical system switch and the water mains tap.



WATER SOFTENER:

If the installation of a water softener has been recommended by the installation engineer because of hard water and problems of scale deposits, it is necessary to follow the instructions of the water softener's manufacturer (periodic regeneration).

MACHINE BODY:

Clean the body of the machine using mild detergents to avoid any damage.

We recommend not to use abrasive sponges that could damage the body panels.



espresso coffee machines

La Spaziale S.p.A.

Via E. Duse, 8 40033

Casalecchio di Reno Bologna - (Italy)

☎ +39 051 611.10.11

📠 +39 051 611.10.11

📠 +39 051 611.10.40

✉ info@laspaziale.com

