

Installation guide for a 12v Voltage Sense Ready Made Split Charge Relay System

Thank you for purchasing this kit from Simply Split Charge.

All of our systems are very easy to install if you follow the simple instructions. You will find all the components and fixings you need in the kit. Please have a look at the instructions below and if you have any questions then please contact us. All our kits should be installed by a qualified auto electrician.

You will need basic tools and fixings to install this kit including

1. Screwdrivers for trim work and fixing components
2. Spanners for battery terminals ECT.
3. Electrical multi-metre to check everything is working as it should when you are finished

in your kit you will have received.

1. Voltage sensed Split charge relay.
2. 2 x 250mm battery to fuse box leads, 1 x 500mm fuse box to relay lead, 1 x 1-9mtr relay to fuse box lead depending on kit ordered
3. 1mtr earth lead.
4. 2 x Fuse holders and Fuses including spares.
5. Split tubing to protect your cable in the engine bay.
6. 15 x cable ties & 10 x self-adhesive bases to keep it all tidy.
7. 15 x screws + drill bit to fix fuse boxes & cable tie bases.
8. 2 x double sided sticky pads to fix fuse boxes if required.
9. Spare terminals + heat shrink to modify leads if required.

Basic wiring diagram for Voltage sense system

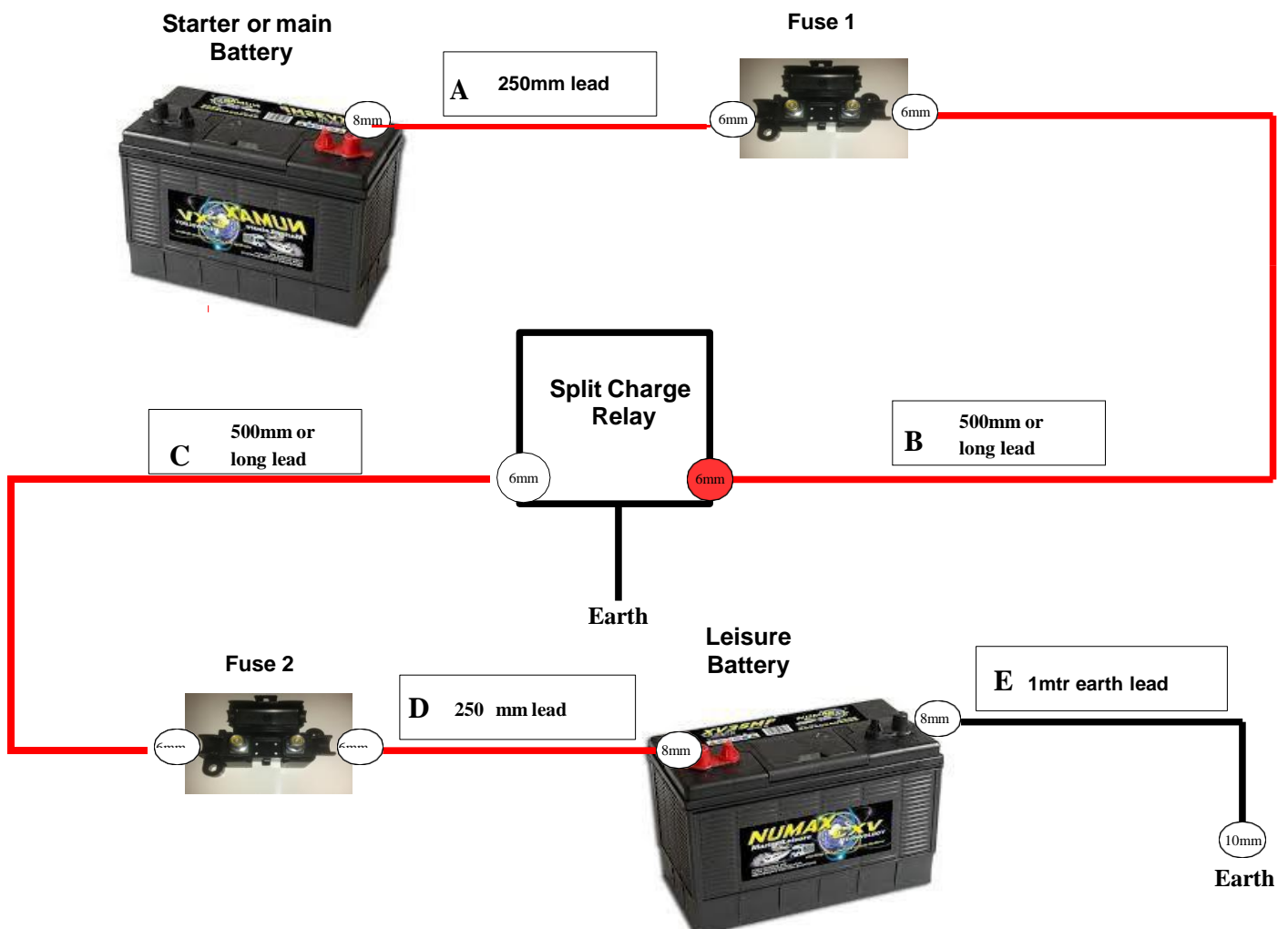

Before starting the installation, the first thing you need to do is make a plan of where you're going to fit all your components. Have a look at the diagram above. This is our basic wiring diagram of your voltage sensed split charge kit.

Things to remember when making your plan are,

That both the fuse boxes need to be positioned as close to the positive terminals of both the starter and the leisure battery as possible. This is because they are fitted to protect the cables running through your vehicle from either the current being too high, or that the cable may become damaged and short circuit.

The Split charge relay can be fitted close to the main starter battery or the Leisure battery. The Voltage sense relay we supply has a red indicator on the front to show you it is working so try to fit it in a position that you can see it if you need to as this may help you in the future if you have a problem. Remember though the relay will need to be earthed so bare that in mind when choosing the position.

1. With the screws provided, cable ties or the sticky pads attach the FUSE 1 and FUSE 2 as close to the main starter Battery and Leisure batteries positive battery terminal as you can.



2. Select where you're going to install the Split Charge relay. There are many types of Voltage Sense Relays. The one in the picture and our instructions is for the Durite, M-Power or VSR style 12V 140amp Relays



You will also see a small black lead that needs to be connected to the vehicle's earth, usually the bodywork so works out the best way to attach this lead.

If you need to modify any of your leads using the extra terminals supplied, please follow the basic lead making instructions below.

On some vehicles or installations, it might be easier to install the leads through smaller holes in the bodywork ECT. before you connect and modify the lead

Trim approx. 10mm of insulation off the end of each lead to attach the terminals.



On each terminal you will see 16-6t, 16-8t. Or 16-10t. The first figure indicates the cable size which is 16mm². The 6, 8 & 10 indicates the bolt hole size.

To fix on your terminals onto your leads first push the end of your cable as firmly into the terminal as you can. You can then crimp or solder the terminal onto your lead. If you don't have either a soldering kit or heavy duty crimps, then you will need to squash the terminal onto the cable as tightly as you can.



Slide the red heat shrink over the ends of the leads until it covers the cable and most of the terminal up to the bolt hole and heat gently until its shrunk tightly over the terminal using a small heat gun or even a normal household lighter.

4. Connecting your leads

Insert any long leads through bodywork and trim until they are all in position to connect to either the relay or the fuse holders.

First connect lead (D) to the Leisure battery positive terminal and tighten. Connect the other end of lead (D) to Fuse 2 but leave loose

Connect lead (C) to the other side of Fuse 2. Insert one of the 100amp strip link fuses and tighten both 8mm nuts. Connect the other end of lead (C) to the "Aux Batt terminal on the underside of the relay and tighten nut.

Connect lead (B) to the "Stater Batt Terminal" of the Split Charge Relay and tighten nut. The relay can now be fixed into the vehicle leaving the small black lead out.

The small black earth lead on the Split Charge Relay needs to be connected to suitable Earth. This can be the vehicles metal body work that's clean of rust or paint or if it will reach it can simply be connected to the negative battery terminal.

Connect the other end of lead (B) to Fuse 1 but do not tighten the nut.

Connect Lead (A) to Fuse 1, Insert another strip link fuse and tighten the 8mm nuts as before. Connect the other end of lead (a) to the Positive Battery terminal on the main Starter battery and tighten.

Connect lead (E) to the negative battery terminal on the Leisure Battery and the other end of lead (E) to a suitable earth. This must be a paint, rust free location to ensure you get a good earth.

Cover any leads in the engine bay with the split plastic tubing to protect them and any area that the leads may get squashed or damaged throughout the vehicle.

Finally using the cable tie bases and cable ties stick or screw on the bases and secure and tidy the leads throughout the kit.

Congratulations you have now installed your split charge kit

Now you kit is installed you can check that everything is working correctly.

Before starting the vehicle to check everything is working its essential you check all the leads are correctly installed and all the terminals are all tight.

You can now Start the Vehicle to check everything is working.

When you start your vehicle the voltage at your main starter battery voltage should rise from 12.5 volts to approx. 14.5 volts. This is because the vehicles charging circuit, the alternator will start working to charge your main battery.

As your Split Charge Relay Kit is now connected to your main battery this will now allow the alternator to charge your leisure battery as well.

The split charge relay switch will on and allow current to flow through to the leisure battery when the voltage rises above 13.3volts and should be indicated by a red LED on the relay.

With a multi-metre you can check that the voltage on both batteries are the same to ensure everything is working ok. The voltage in both batteries should be the same between 14volts to 14.5volts depending on how charged both batteries are.

If Both voltages are the same voltage and the red LED is on, then your split charge relay kit is working correctly and charging your leisure or second battery.

If they are not the same you will need to switch off the vehicle and check all the connections are tight and leads are fitted correctly, the fuses in both fuse boxes are ok and that the earth for the relay and the leisure battery are ok.

You can now go back to the top and start the vehicle again.

If everything is working ok now and both batteries are charging at the same voltage, then continue to the next test.

Switch off your vehicle

The voltage at your main battery should then drop back down. When it drops below 12.8 volts the relay will switch off isolating your leisure battery. This may take a few minutes depending on how well your main starter battery holds a charge. You will hear a click and the red LED will go out on your split charge relay.

When the vehicle is switched off and the LED on the relay is off both batteries will be isolated. This will ensure whatever you are using the leisure battery for you will never drain the main starter battery so you will always have enough power to start the vehicle

If you have a multi-metre you can now check both batteries voltage again. You will probably find them having a voltage if charged between 12volts and 12.8volts and its ok if each battery is different as it will have its own level of charge and this will also prove that both batteries are now isolated and everything is installed correctly.

If you have any problems with this kit or require any help, then please contact us at

simplysplitcharge@gmail.com Or on 01229 718098

so, we can deal with any problems you may have as quickly as we can.

ALL OF THE ABOVE FITTING INSTRUCTIONS ARE A GUIDE ONLY AND THIS KIT SHOULD BE ALWAYS INSTALLED BY AQUALIFIED AUTO ELECTRITION.

SIMPLY SPLIT CHARGE WILL NOT BE LIABLE FOR ANY WORK OR DAMAGES TO YOUR VEHICLE FOR ANY SPLIT CHARGE RELAY KITS FITTED BY YOURSELF OR ANY UNQUALIFIED PERSONS.