

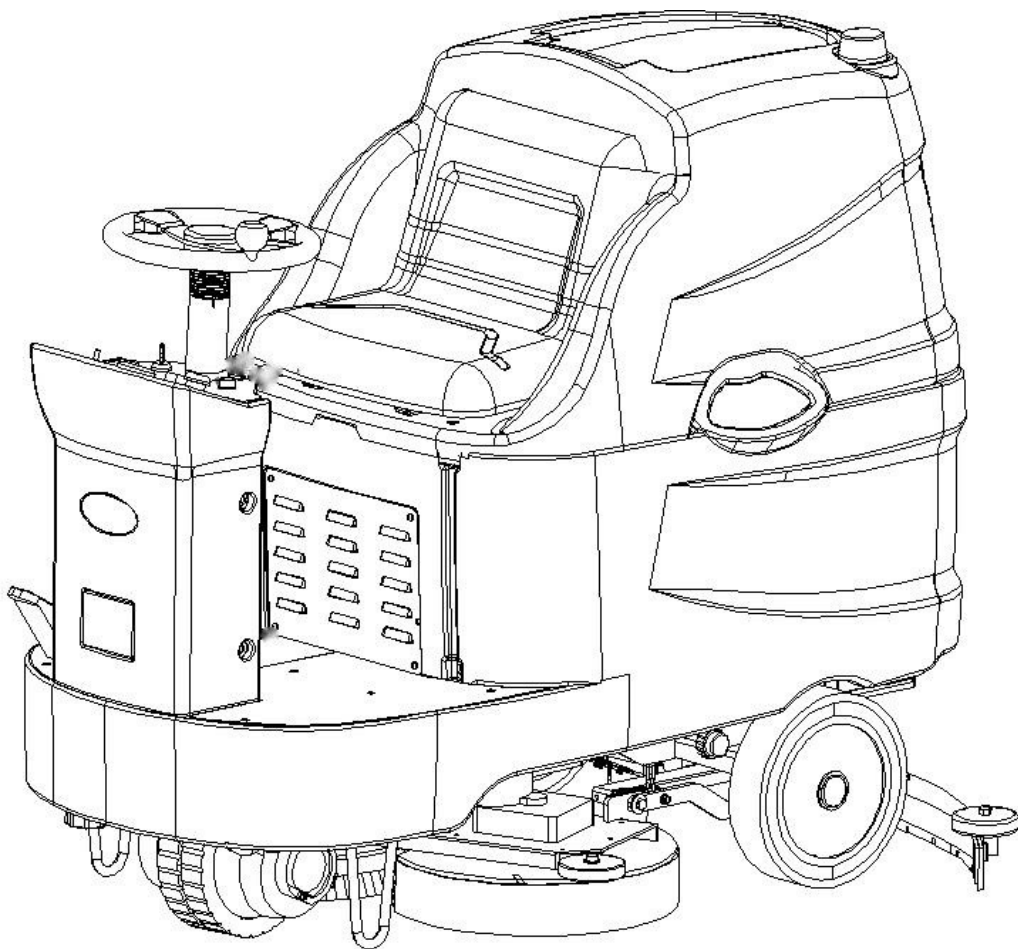

Operation and Maintenance Manual

# ***ACE 32R***



## TABLE OF CONTENTS

<b>PARTS LIST</b>	3
<b>INTRODUCING THE ACE<sup>32R</sup></b>	4
<b>TECHNICAL SPECIFICATIONS</b>	5
<b>SYMBOL LEGEND</b>	6
<b>GENERAL SAFETY GUIDELINES</b>	7
<b><i>PART I: MACHINE PREPARATION</i></b>	
<b>HANDLING THE PACKED MACHINE</b>	8
<b>HOW TO UNPACK THE MACHINE</b>	8
<b>PARTS OF THE MACHINE</b>	9
<b>BATTERY TYPE</b>	11
<b>BATTERY MAINTENANCE</b>	11
<b>BATTERY DISPOSAL</b>	12
<b>RECHARGING THE BATTERIES</b>	12
<b>BATTERY CHARGE LEVEL INDICATOR</b>	13
<b>HOW IT WORKS</b>	13
<b>SUTION DRIVE</b>	13
<b>FAILURE AND PROTECTION</b>	14
<b>FILLING THE SOLUTION TANK</b>	15
<b>RECOVERY TANK</b>	15
<b>ASSEMBLING THE SQUEEGEE</b>	16
<b>ADJUSTING THE SQUEEGEE HEIGHT</b>	16
<b>ASSEMBLING THE BRUSH</b>	17
<b>EMPTY SOLUTION TANK DEVICE</b>	18
<b><i>PART II: MACHINE OPERATION</i></b>	
<b>PREPARING TO USE THE ACE<sup>32R</sup></b>	19
<b>OVERFLOW DEVICE</b>	20
<b><i>PART III: DAILY MAINTENANCE</i></b>	21
<b><i>PART IV: WEEKLY MAINTENANCE</i></b>	23
<b><i>PART V: TROUBLESHOOTING</i></b>	24
<b><i>PART VI: CHOOSING THE RIGHT BRUSHES</i></b>	25

## List CRATE CONTENTS

order	name	unit	quantity
1	ACE <sup>32R</sup> Machine	set	1
2	Charging cable	set	1
3	Battery cable	piece	5
4	Squeegee assembly	set	1
5	Suction hose	piece	1
6	Manual	piece	1
7	QC certificate	piece	1



### ADDITIONAL PARTS

Pad holder 17"  
 Front squeegee blade rubber  
 Rear squeegee blade rubber

### ON RECEIPT OF THE MACHINE

Upon receipt of the machine to the customer, it is essential to conduct a thorough check. This check serves two primary purposes:

- Verification of Shipment Contents:** Ensure that all materials listed in the shipping documents have been received. This step is crucial to guarantee that the delivered package aligns with the documented contents.
- Assessment of Transportation Damage:** Additionally, it is vital to inspect the machine for any signs of damage incurred during transportation. Should such damage be identified, the carrier must take immediate action to determine the extent of the damage. Simultaneously, the carrier must promptly communicate this information to our customer service office.

By taking swift and decisive action in such instances, two critical outcomes can be achieved:

- **Recovery of Missing Material:** Swift action allows us to expedite the acquisition of any missing material. Timely communication can initiate the process of acquiring any items that were not included in the delivered package.
- **Successful Damage Compensation:** Prompt identification and reporting of transportation-induced damage enhance the likelihood of successfully claiming compensation for any harm inflicted on the machine during transit.

Furthermore, to ensure the safety of the machine operator and to prevent any potential harm to the machine itself, it is strongly advised to carefully review the contents that are indicated by a specific symbol. This symbol serves as an indicator of crucial information that warrants thorough attention.

Your commitment to following these procedures will not only safeguard the interests of all parties involved but also contribute to the seamless operation and longevity of the machine.

## INTRODUCING THE ACE<sup>32R</sup>

This is the ACE<sup>32R</sup>, a ride-on floor scrubbing machine, designed to effectively clean various types of flooring using both mechanical action from its rotating brush and chemical action from a water/detergent solution. As it moves forward, it not only cleans the floor but also collects loosened dirt and excess detergent.

It's important to note that the machine should only be used for its intended purpose. Even the most advanced machines can only perform well when used correctly and maintained properly. We strongly recommend thoroughly reading and revisiting this instruction booklet whenever you encounter challenges while using the machine. If needed, our assistance service, in collaboration with our dealers, is readily available for advice or hands-on support.

### Intended Use:

The scrubbing machine is exclusively designed for professionally cleaning surfaces and floors in industrial, commercial, and public settings. For optimal performance, it should only be operated indoors, ideally in enclosed or covered spaces.

Please be aware of the following restrictions:

1. **Avoid Rain and Water Jets:** The machine should never be used in rainy conditions or under direct water jets.
2. **No Hazardous Dusts or Inflammable Liquids:** Do not use the machine to pick up dangerous dusts or flammable liquids, especially in environments with potentially explosive atmospheres.
3. **Non-Transport Usage:** The machine is not suitable for transporting people or objects.

By adhering to these guidelines, you'll ensure the safe and effective operation of the scrubbing machine. Your attention to proper usage will not only prolong the machine's lifespan but also enhance its cleaning performance

---

**TECHNICAL SPECIFICATIONS**

<b>TECHNICAL SPECIFICATIONS</b>	<b>ACE<sup>32R</sup></b>
Scrub path	39 in
Squeegee width	47 in
Disc brush rotations	180
Brush motor	450W * 2
Brush pressure	143 lbs
Traction motor	650W
Vacuum motor	730W
Solution tank	47.5 gal
Recovery tank	52.8 gal
Minimum bending radius	44 in
Machine dimensions LWH (Excluding Squeegee)	59" x 40" x 49.6"
Battery compartment (length/width)	23" x 19"
Working voltage	36V
Battery weight (max)	462 lbs
Machine weight (empty and without batteries)	507 lbs
Gross weight in running order (machine + batteries + water + operator)	1521 lbs

**SYMBOL LEGEND**



**Attention**



**Manual**



**Watch Your Hand**



**Warning: hand injury**



**No open flames**



**Caution: Danger of exhalation of gas**



**Recycle**

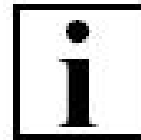

**Information**



**corrosion**



**Caution: shock**



**Dangerous waste**



**Lifting means**

## GENERAL SAFETY GUIDELINES

The regulations below must be carefully followed in order to avoid harm to the operator and damage to the machine.

- ◆ Read machine labels carefully, replace if damaged
- ◆ Use machine only by authorized, trained personnel.
- ◆ Pay attention to others while using.
- ◆ Avoid mixing different detergents.
- ◆ Don't store the machine with residual liquid.
- ◆ The storage temperature must be between -13°f and 131°f.
- ◆ Conditions of use: room temperature between 32°f and 104°f with relative humidity between 30 and 95%.
- ◆ Do not use the machine in an explosive atmosphere.
- ◆ Do not use the machine as a means of transport.
- ◆ Avoid acid solutions.
- ◆ Avoid using brushes when machine is stationary.
- ◆ Do not vacuum flammable liquids
- ◆ Do not use the device to collect dangerous powders.
- ◆ In the event of a fire, use a powder extinguisher. Do not use water.
- ◆ Avoid knocking against objects.
- ◆ Select operating speed as per traction.
- ◆ Avoid using on steep surfaces.
- ◆ Store properly when not in use.
- ◆ Use machine only in authorized areas.
- ◆ Perform routine maintenance.
- ◆ Use original spare parts for replacements.
- ◆ Use specified brushes.
- ◆ Use emergency brake in risky situations.
- ◆ Switch off before maintenance.
- ◆ Ensure full electrical connection after maintenance.
- ◆ Do not remove protection devices.
- ◆ Avoid corrosive substances and high-pressure water.
- ◆ Service after 200 hours of use.
- ◆ Prevent scale formation in solution tank.
- ◆ Check hatches and covers before use.
- ◆ Empty recovery tank before moving.
- ◆ Observe disposal laws for consumables.
- ◆ Dispose materials properly.

**I. MACHINE PREPARATION**

**HANDLING THE PACKED**

**MACHINE**

The machine is fixed to a pallet, which is specially designed for forklift handling.

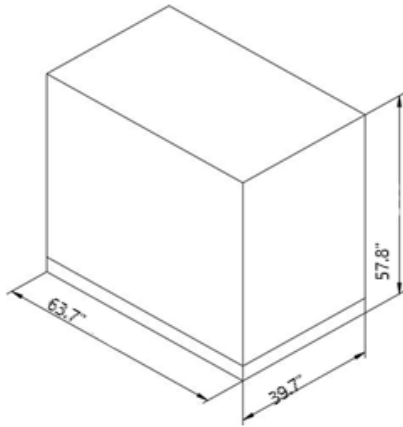

Overall dimensions of the package:

L: 63.7"

W: 39.7"

H: 57.8"

Total weight (Including batteries) : 455KG.



**DO NOT STACK ANYTHING ON TOP OF MACHINE PALLET.**

**HOW TO UNPACK THE MACHINE**

1. Remove the outer packaging
2. The machine is fixed to the pallet with wedges and belts. Remove belts.
3. Get the machine down from the pallet. Keep pallet for transport.

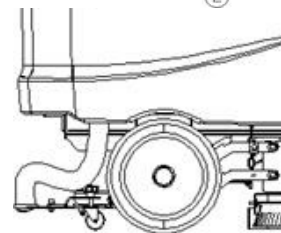
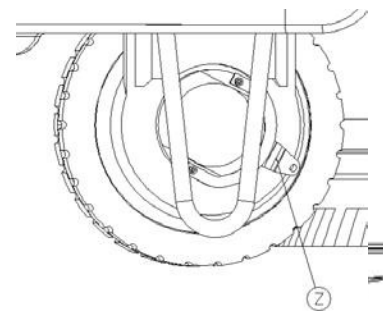

Handle the packed product with suitable lifting means that comply with the legal requirements.



During this operation, ensure that there are no people or objects near the machine.



OVERALL INTRODUCTION

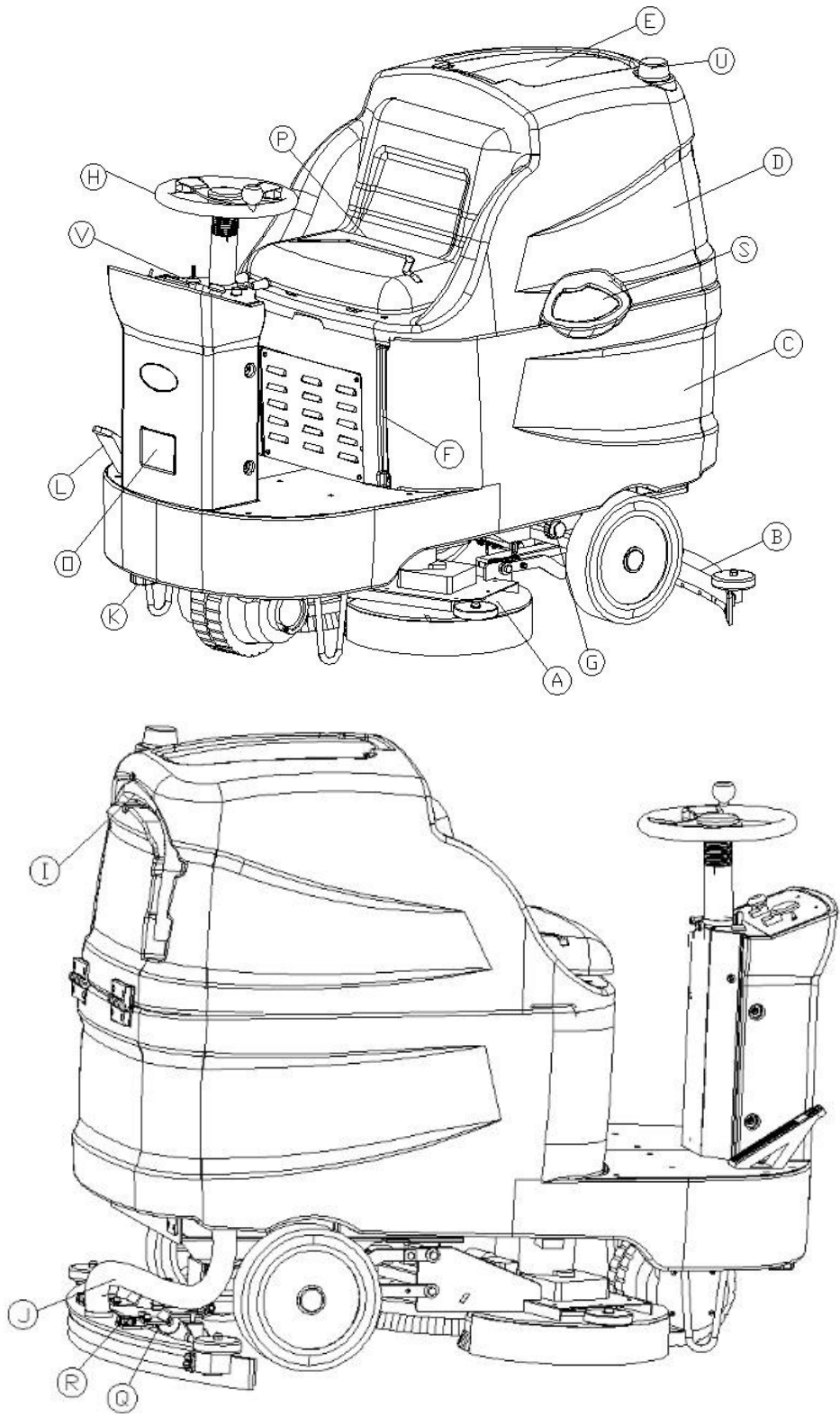

- |                                      |                          |                     |                         |
|--------------------------------------|--------------------------|---------------------|-------------------------|
| A: Brush head assembly               | B: Squeegee assembly     | C: Solution tank    | D: Recovery tank        |
| E: Recovery tank cover               | F: Water level adjuster  | G: Filter           | H: Steering wheel       |
| I: Drain pipe                        | J: Suction pipe          | K: Drain            | L: Drive pedal          |
| O: Light                             | P: Chair                 | Q: Squeegee support | R: Handwheel            |
| S: Water filling nozzle              | T: Cover                 | U: Caution light    | V: Instrument panel     |
| W: Level indicator for battery meter | X: Emergency stop button | Y: Key switch       | Z: Speed-control switch |

**Control panel**

W: Level indicator for battery meter

X: Emergency stop button Y:

Key switch

Z: Speed-control switch Z1:

Brush switch Z2: Squeegee

switch Z3: Forward back switch

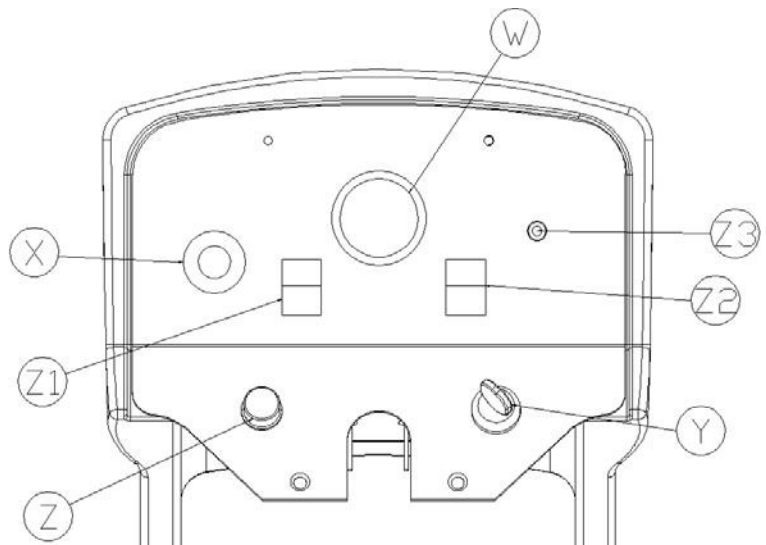

**TYPE OF BATTERY**

To power the machine there are three types of batteries below:

- Lead-acid battery composed of liquid plumbic acid, called WET Battery.
- Liquid electrolyte lead traction batteries, called AGM Battery.
- Sealed traction batteries with gas recombination or gel technology, called GEL Battery.

For a good operating performance, we suggest the use of six 6V - 200 Ah batteries.

**OTHER TYPES MUST NOT BE USED.**

Max size of the battery: Length=10" Width=7" Height=8.5"

Max weight of the battery: 79 lbs

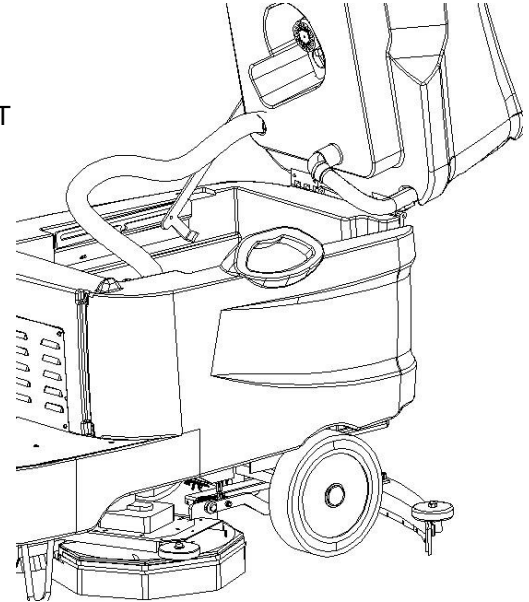

You are advised to always wear protective gloves, to avoid the risk of serious injury to your hands.



You are advised to only lift and move the batteries with lifting and transportation means suitable for the specific weight and size. Connect the battery clamp at the top of the box and then put the battery into the battery compartment.

**BATTERY MAINTENANCE**

The type of battery must satisfy the requirements of Standard CEI21-5 description  
The dimensions of the battery compartment are: 24" x 21" x 15"

To insert batteries proceed as follows:

1. Lock the machine by activating the electronic brake, and then turn the lever (on the rear right-hand side of the machine) count-clockwise.
2. Make sure the recovery tank is empty, turn it as far as it will go.
3. House the batteries in the compartment.
4. Turn the recovery tank back into position.



You are advised to use airtight batteries only, to avoid the leakage of acids!



You are advised to always wear protective gloves, to avoid the risk of serious injury to your hands.



This process must be carried out by qualified personnel. An incorrect connection may cause problems with machine functioning.

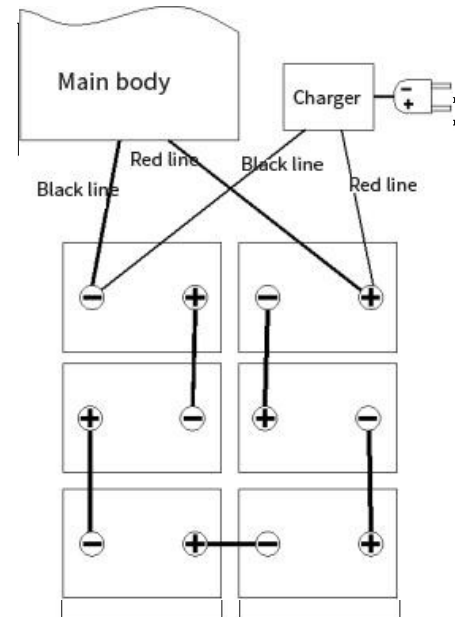

### BATTERY MAINTENANCE

Follow battery manufacturer's maintenance instructions. Choose suitable charger. Dispose of worn-out batteries properly.

### BATTERY DISPOSAL

Disconnect and remove worn-out batteries by trained personnel. Dispose according to laws and regulations.

### RECHARGING THE BATTERIES

Recharge batteries before complete discharge to prevent damage. Follow charging indicator. Keep recovery tank raised during recharging.

NOTE: never leave the batteries completely discharged, even if the machine is not being used.



Danger of gas exhalation and leakage of corrosive liquids



Danger of fire: do not go near with free flames

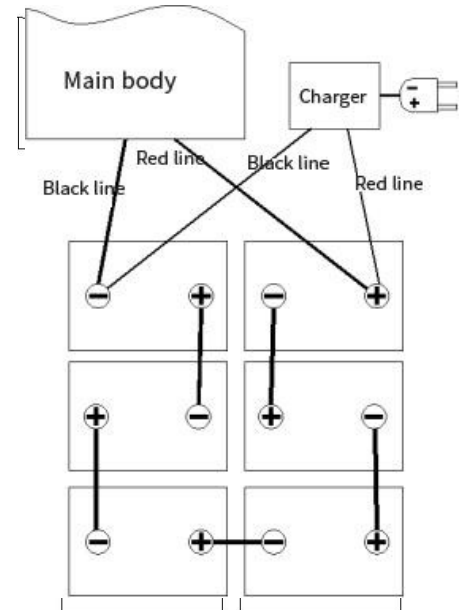

## BATTERY CHARGE LEVEL INDICATOR

The battery indicator has 8 positions and 1 blinking light.

8=100%      blinking light = 0%

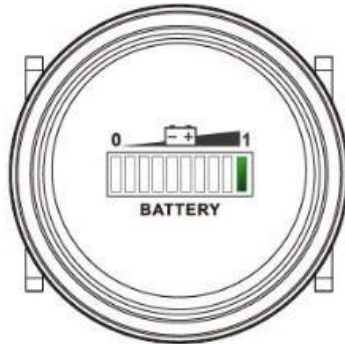

Shortly after the indicator light activates, the brush motor will automatically deactivate. However, there's still enough remaining charge to carry out the drying process before needing to recharge.

### HOW IT WORKS

#### Forward Movement:

- To move the machine forward, press the forward button (Z3) and depress the drive pedal (L).
- The speed can be adjusted by varying the pressure applied to the pedal (L).

#### Backward Movement:

- For backward movement, choose the backward button (Z3) and push down the drive pedal (L).
- Adjust the speed by altering the pressure on pedal (L).

#### Walking Forward with Squeegee Dropped:

- When the squeegee is dropped, the machine can only move forward.

#### Brush Operation:

- To engage the brush, press the forward button (Z3), lower the brush head, and push down the drive pedal (L).
- The brush will only function when the brush head is lowered and the drive pedal (L) is pressed. It will stop if the brush head is raised or if the drive pedal (L) is released.

#### Suction (Squeegee) Operation:

- For squeegee operation, press the forward button (X) and drop the squeegee.
- After sixty seconds, the squeegee operation will cease if the squeegee is raised.

By following these instructions, you can control the machine's movements and functions effectively.



The reverse speed is lower than the forward speed to comply with current health and safety standards

When making even brief reverse movements, make sure the squeegee is raised

**FAILURE AND PROTECTION**

When battery is low, all operations are prohibited.

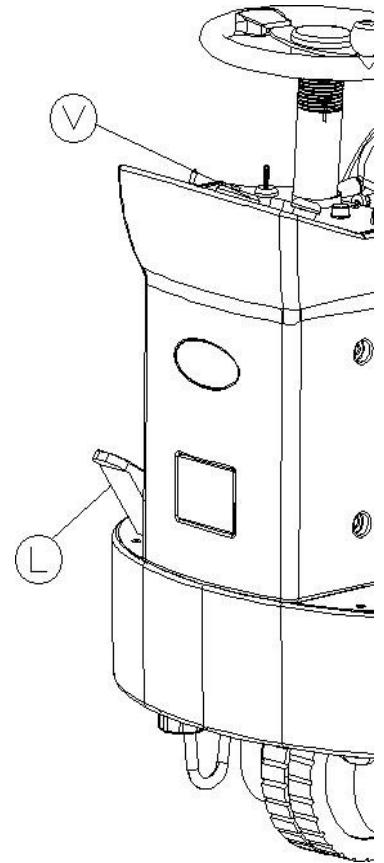

## FILLING THE SOLUTION TANK

Before filling the solution tank:

1. Remove the filler plug on the left of the machine and check that the solution filter is installed properly;
2. Check that the solution filter cap (K), under the solution tank in the front left of the machine is properly closed.



The recovery tank must be completely empty each time the solution tank is filled

The solution tank can be filled as below:

Removing the inlet cap (S) and filling it using a rubber tube, left side of the machine. Fill with clean water at a temperature not exceeding 50°C.

The amount present in the tank can be seen through the level pipe on the front-right of the seat.

The solution tank has a maximum capacity of about 100 liters. Add the liquid to the tank in the concentration and manner indicated on the detergent manufacturer's label.

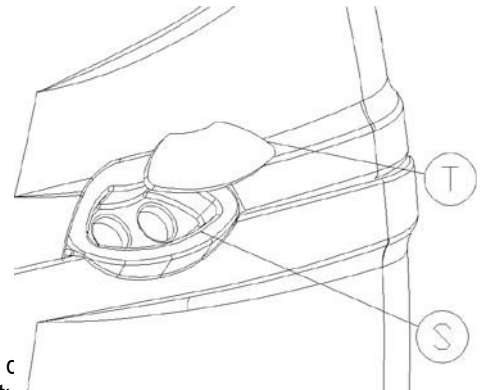

Always use detergents whose manufacturer's label indicates their suitability for scrubbing machines. Do not use acid or alkaline products or solvents without this indication. Acid or alkaline maintenance detergents can be used, as long as they have PH values between four and ten, and do not contain oxidizing agents, chlorine or bromine, formaldehyde, mineral solvents.



Protective gloves should always be worn before handling detergents or acidic or alkaline solutions to avoid serious injury to hands



Always use low foam detergent. To avoid the production of foam, before starting to clean, put a minimum quantity of antifoam liquid into the recovery tank. Do not use pure acids.

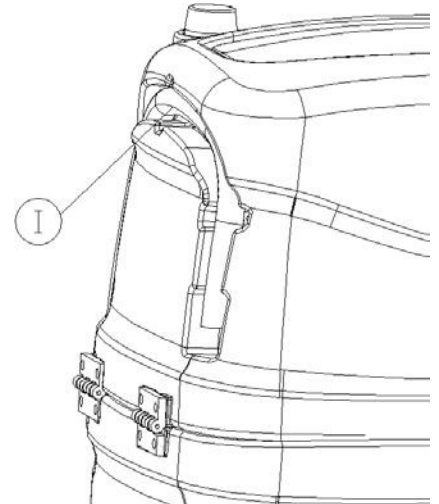

## RECOVERY TANK

Make sure the recovery tank is empty, otherwise empty it completely. Check the cap of the drainage tube (I) (on the rear of the machine) is correctly closed.

## ASSEMBLING THE SQUEEGEE

The squeegee is packaged separately for shipping. Follow the instructions below to assemble.

1. Lift the squeegee (Q), push the Squeegee lifting switch (N) to move it clockwise.
2. Turn the main switch key counter-clockwise to the "0" position.
3. Remove the key from the instrument panel.
4. Loosen the knobs (R) in the squeegee pre-assembly.
5. Insert the left-hand squeegee pin in the left-hand slit of the squeegee connection.
6. Insert the right-hand squeegee pin in the right-hand slit of the squeegee connection, then tighten the knob (R), making sure the washer and spring adhere in the upper part of the squeegee support.
7. Insert the suction hose (J) in the squeegee sleeve.



These operations must be carried out using protective gloves to avoid any possible contact with the edges or tips of metal objects

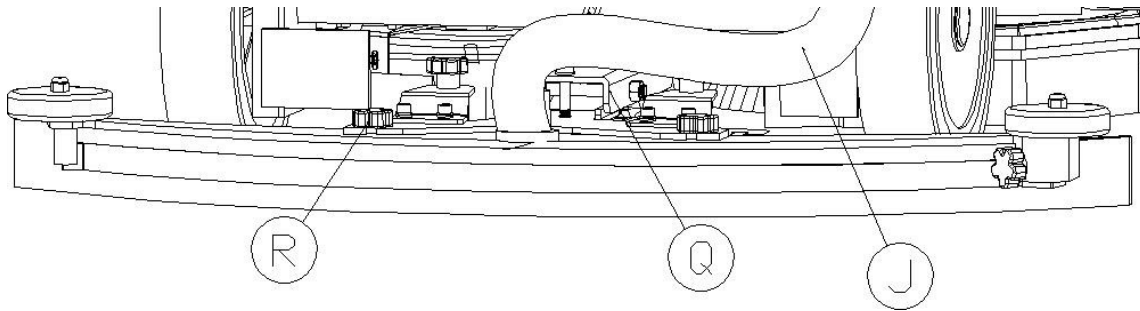

## ADJUSTING THE SQUEEGEE HEIGHT

The height of the squeegee must be adjusted on the basis of the state of wear and tear of the rubber. Carry out the following operations for adjustment:

1. Unscrew the locking nut;
2. Rotating wheels, adjusting its height;
3. Tighten lock nut once the required height is reached.



**ASSEMBLING THE BRUSH**

To assemble the brushes of the brush head body, follow these instructions:

1. Make sure that the main switch is in the "OFF-0" position.
2. Lift the brush head by pushing brush head lifting switch (M) to move the brush head anticlockwise.
3. With the brush head in a high position, put the brushes in the housing of the plate under the brush head, turning them until the three buttons go into the niches of the plate itself; turn the brush clockwise until the pin is pushed towards the coupling spring and is locked into place.

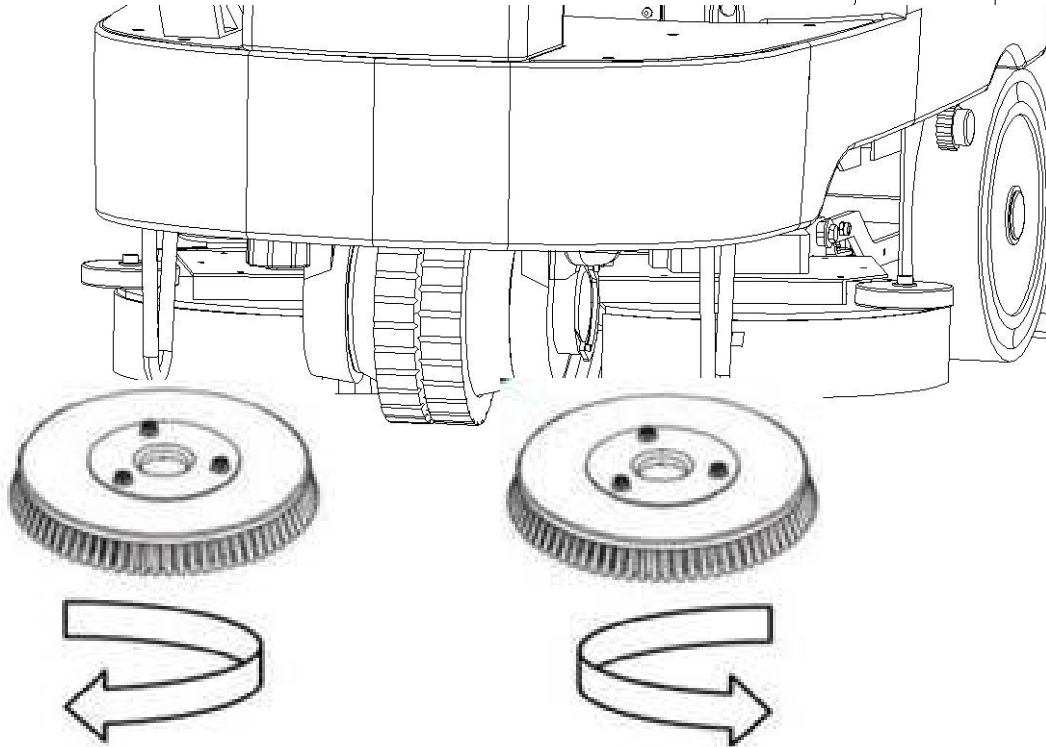



You are always advised to wear protective gloves, to avoid the risk of serious injury to your hands.

Cut down all electric current in order to protect your hands



During this operation, ensure that there are no people or objects near the brush.

**ATTENTION:** Check the brush is correctly inserted. If this is not the case, the machine could move in an irregular, sudden manner.

It is recommended to switch the sides of the brushes daily. Change the right brush to the left side, and the left side to the right. This ensures there is no un-even wear on any parts of the brush.

### EMPTY SOLUTION TANK DEVICE

1. To check the quantity of water in the solution tank there is a level indicator tube (F) placed on the right of the driver seat.
2. Push machine to the drain area, unscrew the drain-pipe (K) and drain the water from the tank until empty.
3. Tightened the Solution tank drain pipe (K) cap, and then put it back to its position.

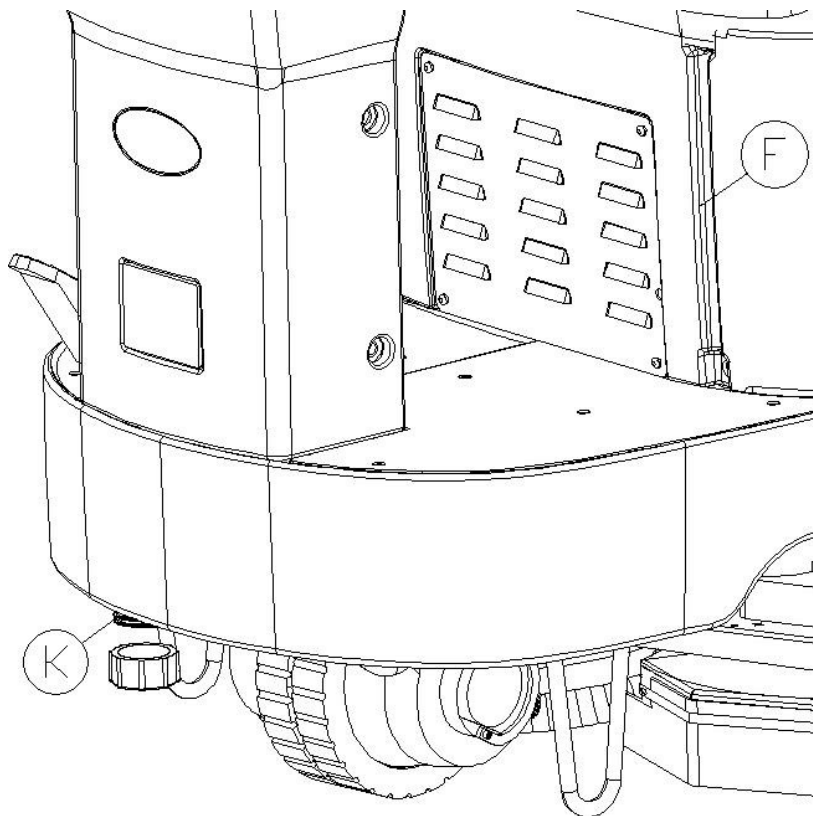

## II. MACHINE OPERATION

### PREPARING TO USE THE ACE<sup>32R</sup>



Make sure the recovery tank is empty before starting.

1. Check the key switch (Y) is on "0"; if this is not the case, turn the key of the main switch to "0".
2. Connect the battery connector to the electric system connector.
3. Check the electronic brake
4. Sit on the driver's seat
5. Turn the key of the main switch a quarter of a turn. The display on the instrument panel will immediately come on. Please refrain from performing any operations for the next 5 seconds, as the machine initiates a self-check during this time.
6. Lower the brush head by turning the right lever clockwise, then lower the squeegee turning the left lever anticlockwise;

#### 1. Detergent Dispensing and Vacuum Activation:

- Once the forward movement pedal is engaged while the brush head is in its operational position, the solenoid valve activates to dispense the detergent solution.
- When the squeegee is also in its operational position, the vacuum motor will start and begin its operation.

#### 2. Selecting Forward Gear:

- Choose the forward gear by using the switch located on the steering column.

#### 3. Initiating Forward Movement:

- To start moving the machine forward, press the forward-back switch (Z3).

#### 4. Moving Backward:

- To move backward, first bring the machine to a stop.
- Select the desired direction using the forward-back switch (Z3) on the steering column. Lift the squeegee from the ground before moving.
- Then, depress the pedal (L) to engage reverse movement.

During the initial meters of movement, ensure that an adequate detergent solution is being dispensed and that the squeegee is efficiently drying the cleaned area.

The machine will continue to operate with optimal efficiency until the battery's charge is depleted or the detergent solution is exhausted.



The squeegee must be lifted from the ground during backward movement.



During the first feet, check that there is sufficient solution and that the squeegee dries well. The machine will now begin to work with full efficiency until the battery is dead or the detergent solution has finished.

**OVERFLOW DEVICE**

When the recovery tank is full, the overflow valve shuts off the air to the suction motor intake.

**EMERGENCY BUTTON**

In the event of any issues during operation, follow these steps:

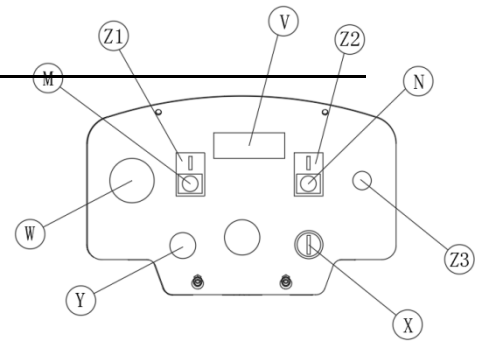

1. Press the emergency button (W), located under the seat.
  - This action immediately breaks the electric circuit between the batteries and the machine system.
  - As a result, the machine comes to a stop and the electric brake engages.
2. To resume work after resolving the problem:
  - Turn off the machine using the key.
  - Put the emergency button (W) back to its normal position.
  - Turn the key back on.

**AFTER USING THE MACHINE**

After using the machine, and before maintenance follow these steps:

1. Close the tap by moving the knob upwards.
2. Lift the brush head by pushing the Brush head lifting switch (M), then lift
3. Turn the machine off by turning the key one quarter turn counter-clockwise and remove it from the panel.
4. Disconnect the hose (I) from its seat, unscrew the drainage cap (H) and empty the recovery tank.
5. Screw the drainage cap and replace the tube (I) back to the seat.



Be sure to remove the key as well as tighten auxiliary brake on the drive wheel when the operator leaves the seat, and if the machine will be parked for a long time



### III. DAILY MAINTENANCE

#### I. DAILY MAINTENANCE

##### CLEANING THE RECOVERY TANK

1. Disconnect the tube (I) from its seat, unscrew the drainage cap (H) and empty the recovery tank



Before performing any maintenance, remove the keys from the panel and disconnect the battery connector of the machine.

2. Lift the recovery tank (E);
3. Clean and rinse the recovery tank
4. Reassemble all the elements.



Be careful not to hit the recovery tank float directly, as this could damage the float.

##### CLEANING THE SOLUTION TANK FILTER

Careful cleaning of the detergent/water solution filter ensures a better working capacity. Proceed as follows for cleaning

1. Check the main switch is on "0";
2. Loosen the filter (G) cap on the front of the machine
3. Remove the internal filter cartridge and rinse everything thoroughly with running water
4. Reassemble all the elements



These operations must be carried out using gloves to protect against contact with dangerous solutions.

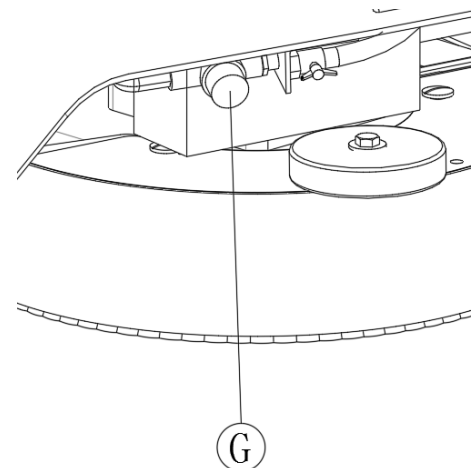
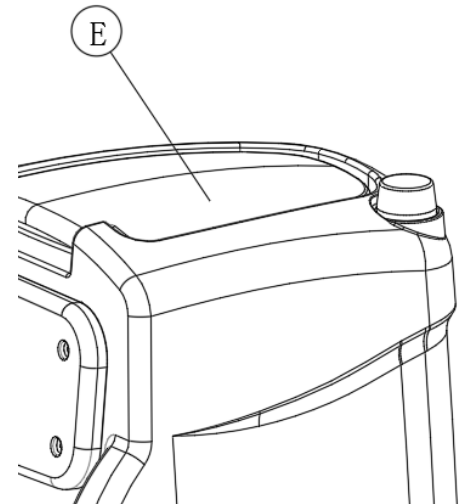

## CLEANING THE SQUEEGEE

The cleaning of the vacuum unit ensures better drying and cleaning of the floor as well as greater duration of the suction motor.

1. Remove the tube (J) from the squeegee.
2. Release the Squeegee (Q) fixed nut (R), then take down the squeegee (B).
3. Carefully clean the inside of the squeegee and rubbers.
4. Every week, or whenever suction seems to be unsatisfactory, check the squeegee tube is not obstructed.
5. Reassemble all the elements again.



This operation must be carried out using gloves to protect against contact with dangerous solutions

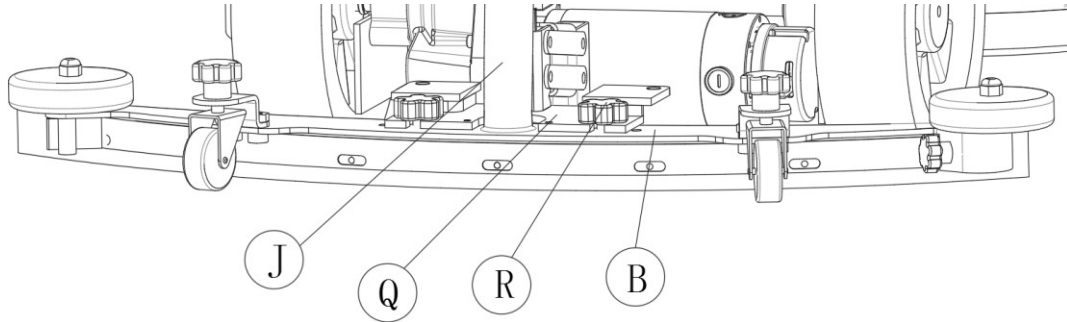

## CLEANING THE BATTERY COMPARTMENT

Empty the battery compartment each time you remove the batteries, check there is no fluids.



This operation must be carried out using gloves to protect against contact with dangerous solutions.



Danger of fire: do not go near with free flames.



Danger of exhalation of gas and leakage of corrosive liquids.

## IV: WEEKLY MAINTENANCE

### CLEANING THE BRUSH

5. Raise the brush head by pushing brush head lifting switch (M).
6. Turn down the brush.



During this operation, ensure that there are no people or objects near the brush.

7. Take the brush and clean it under a flowing jet of water.
8. Reassemble it on the brush head body.

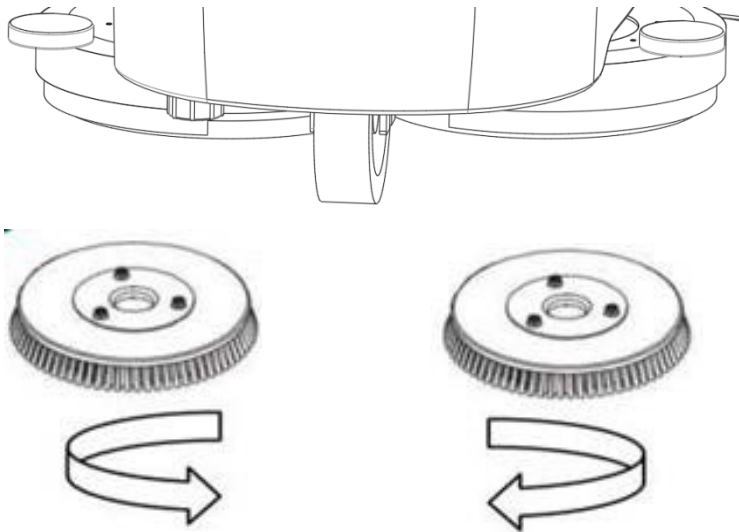

### Replacing the squeegee rubbers

1. Remove the tube (J) from the sleeve on the squeegee.
2. Rotate the nut (R) the squeegee.
3. Unthread the squeegee (B)
4. Loosen the screw that blocks the rubber-pressing blade and take down the plate stainless steel.
5. Reassemble the rubber,

Then reassemble all the elements

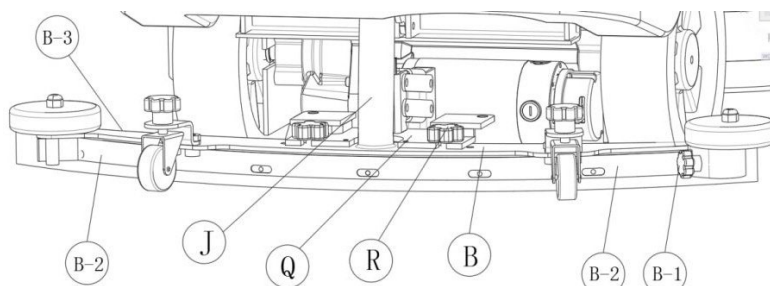

## I TROUBLE SHOOTING

Check common problems before seeking assistance

Problem	Possible Cause	Solution
Brush motor will not work	<ol style="list-style-type: none"> <li>1. Electric not working</li> <li>2. Low voltage</li> <li>3. Motor not connected properly</li> </ol>	<ol style="list-style-type: none"> <li>1. Plug in the power and make sure the fuses are working</li> <li>2. Make sure the batteries are fully charged</li> <li>3. Check motor connections</li> </ol>
Low solution/ no solution flow	<ol style="list-style-type: none"> <li>1. Filter or joint is clogged</li> <li>2. The solenoid valve is clogged or needs replaced</li> <li>3. Solution tank is empty</li> </ol>	<ol style="list-style-type: none"> <li>1. Clean out the filter or joint</li> <li>2. Take out the solenoid valve, then wash it</li> <li>3. Fill solution tank</li> </ol>
Machine will not suction	<ol style="list-style-type: none"> <li>1. The cover of recovery tank is not sealed</li> <li>2. Hose clamp loose</li> <li>3. Suction Motor loose or defection</li> <li>4. Suction hose is partially blocked</li> <li>5. Battery low</li> <li>6. Recovery tank is full</li> </ol>	<ol style="list-style-type: none"> <li>1. Check the seal</li> <li>2. Check the hose clamp</li> <li>3. Make sure the is motor install correctly</li> <li>4. Clean the hose</li> <li>5. Charge the batteries</li> <li>6. Empty recovery tank</li> </ol>
Battery terminal cable is hot	<ol style="list-style-type: none"> <li>1. Cable has bad connection</li> <li>2. Cable has a short or break</li> </ol>	<ol style="list-style-type: none"> <li>1. Tighten the screw</li> <li>2. Replace the battery cable</li> </ol>
Water absorption is not even	<ol style="list-style-type: none"> <li>1. Suction motor does not work</li> <li>2. Suction hose is blocked</li> <li>3. The squeegee is blocked with something</li> <li>4. The squeegee is total worn-out</li> <li>5. The height of the squeegee is not suitable</li> </ol>	<ol style="list-style-type: none"> <li>1. Check the motor</li> <li>2. Clean the suction hose</li> <li>3. Clean the squeegee</li> <li>4. Change squeegee blades</li> <li>5. Adjust the height of the squeegee</li> </ol>
The brush does not clean well	<ol style="list-style-type: none"> <li>1. The brush motor does not work</li> <li>2. Dirt will not come off floor</li> <li>3. Brush is scratching the floor</li> <li>4. Something is tangled in the brush</li> </ol>	<ol style="list-style-type: none"> <li>1. Check the motor</li> <li>2. Use appropriate cleaning fluid</li> <li>3. Change the brush</li> <li>4. Clean the brush</li> </ol>



**I CHOOSING THE RIGHT BRUSHES****II POLYPROPYLENE BRUSH (PPL)**

Used on all types of floors. Good resistance to wear and tear, and hot water (no greater than 140°F). Brush is non-hygroscopic and retains its characteristics even when working in wet conditions.

**NYLON BRUSH**

Used on all types of floors. Good resistance to wear and tear, and hot water (no greater than 140°F). Brush is hygroscopic and easy-extended will not retain characteristics when working in wet conditions.

**ABRASIVE BRUSH**

The bristles of this type of brush are extremely hard. It is used to clean very dirty floors. To avoid floor damage, work only with the pressure strictly necessary.

**STEEL BRUSH**

It is made up of steel wire and artificial fiber blends and used to clean rough roads, floors with big joints or dirt which is difficult to clean up.

**THICKNESS OF THE BRISTLES**

Thicker bristles are more rigid and are therefore used on smooth floors or floors with small joints. On uneven floors or those with deep joints, it is advisable to use softer bristles which can enter the gaps more easily.

Remember that when the bristles are worn and therefore too short, they will become rigid and are no longer able to penetrate and clean deep down. In this case, like with over-large bristles, the brush tends to jump.