

# A-CLASS GulfStream

A Condensing Primary Storage Appliance  
for Hot Water Supply and Central Heating

## DESIGN, INSTALLATION AND SERVICING INSTRUCTIONS

### APPLIANCE TYPE

- This is a Floor Mounted Fan Assisted Balanced Flue Gas Condensing Combination appliance for hot water supply and central heating.
- This appliance is for use with Natural Gas (G20) only at 20mbar.
- This appliance for use in GB & IE only
- Appliance category: I<sub>2H</sub>
- Appliance types: C<sub>13'</sub>, C<sub>53'</sub>, C<sub>33</sub>

### MODELS

These instructions cover the following models and only apply to the appliances sold and installed in Great Britain (GB) and Ireland (IE). These appliances have been certified for safety and therefore it is important these instructions must be followed. The appliance and the installation specifications of the appliances must not be modified unless recommended and approved by Gledhill Water Storage Limited.

Model Ref	Sedbuk Band	Maximum Space Heating Load (kW)	Gas Council No.	Heating System Type
GS <sup>A</sup> -CLASS 12/OV	A	10.0	55-317-33	Open vented heating system
GS <sup>A</sup> -CLASS 12/SS	A	10.0	55-317-34	Sealed heating system
GS <sup>A</sup> -CLASS 20/OV	A	18.0	55-317-35	Open vented heating system
GS <sup>A</sup> -CLASS 20/SS	A	18.0	55-317-36	Sealed heating system
GS <sup>A</sup> -CLASS 30/OV	B	26.0	55-317-37	Open vented heating system
GS <sup>A</sup> -CLASS 30/SS	B	26.0	55-317-38	Sealed heating system

All models are WRAS approved and listed.

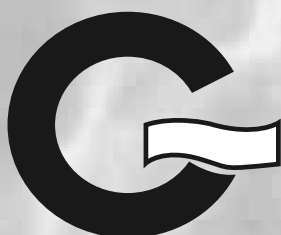

### SAFETY

#### 1. The Gas Safety (Installation and use) Regulations 1998

"In your own interest, and that of safety, it is law that all gas appliances are installed by competent persons, in accordance with the above regulations. Failure to install appliances correctly could lead to prosecution."

#### 2. Control of Substances Harmful to Health

When working with insulation materials, avoid inhalation as it may be harmful to health, avoid contact with skin, eyes, nose and throat. Use disposable protection. Dampen the material and ensure that the area is well ventilated.

#### 3. INSTRUCTIONS

- Read these Instructions before installing or lighting the appliance
- Leave these instructions (which include the Benchmark Gas Boiler Commissioning Checklist) in the pocket provided on the back of the appliance front panel.

# IMPORTANT NOTICES

## 1. Handling and Storing the Appliance

This appliance should be handled carefully to avoid damage and the recommended method is shown opposite. A team lift - When lifting the unit:-

- Work with someone of similar build and height if possible.
- Choose one person to call the signal
- Lift from the hips at the same time, and then raise the unit to the desired level.
- Move smoothly in unison.

The appliance is supplied shrink wrapped on a timber installation base. Carrying handles are provided towards the top of the left hand side of the casing and at the bottom of the opposite side.

If the unit needs to be stored prior to installation it should be stored upright in a dry environment and on a level base/floor.

**Note:** Although the above guidance is provided any manual handling/lifting operations will need to comply with the requirements of the Manual Handling Operations Regulations issued by the H.S.E.

The appliance can be moved using a sack truck on the left hand face although care should be taken and the route should be even. In apartment buildings containing a number of storeys we would recommend that the appliances are moved vertically in a mechanical lift. *If it is proposed to use a crane expert advice should be obtained regarding the need for slings, lifting beams etc.*

## 2. System Installation

Any installation must be in accordance with the relevant requirements of the current issue of Gas Safety (Installation and Use) Regulations, Local Building Regulations, Local Water Company Bylaws and Health & Safety Document No. 635 – The Electricity at Work Regulations 1989. The detailed recommendations are contained in the current issue of the following British Standards and Codes of Practices:-

BS 5440 Pts. 1 & 2; BS 5449; BS 5546; BS 7074 Part 1; BS 6700; BS 6798; BS 6891, BS 7593, IGE/UP/7/1998

## 3. Gas Consumer Council

The Gas Consumer Council (GCC) is an independent organisation which protects the interest of all gas users. If you need advice, you will find the telephone number in your local telephone directory under Gas.

## 4. Equipment selection

This information is provided to assist generally in the selection of equipment. Responsibility for selection and specification of our equipment must, however, remain that of our customers and any expert or consultants concerned with the installation(s). Therefore please note that:-

- a) We do not therefore accept any responsibility for matters of design selection or specification for the effectiveness of an installation containing one of our products.
- b) All goods are sold subject to our Conditions of Sale which are set out in the Appendix to this document.

## 4. Warnings

- a) The GulfStream<sup>A-Class</sup> is for use on Natural Gas only and must not be used on any other gas.
- b) This appliance must be serviced and installed by a competent person e.g. CORGI Registered installer. All CORGI registered installers carry a CORGI ID Card and have a registration number. You can call CORGI direct on 01256 372300.

### c) Building Regulations and Benchmark Commissioning

The Building Regulations (England & Wales) require that the installation of a heating appliance be notified to the relevant Local Authority Building Control Department. From 1st April 2005 this can be achieved via a Competent Person Self Certification Scheme as an option to notifying the Local Authority directly. Similar arrangements will follow for Scotland and will apply in Northern Ireland from 1st January 06.

## Issue 5: 06-08

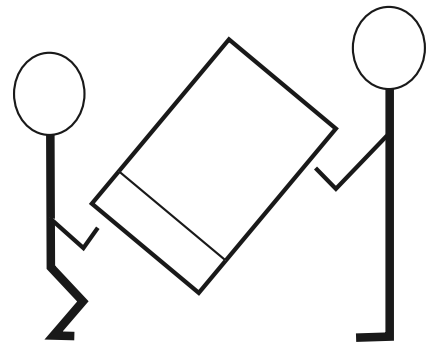

CORGI operates a Self Certification Scheme for gas heating appliances.

These arrangements represent a change from the situation whereby compliance with the Building Regulations was accepted if the Benchmark Logbook was completed and this was then left on site with the customer.

With the introduction of a self certification scheme, the Benchmark Logbook is being replaced by a similar document in the form of a commissioning check list and a service interval record is included with all gas appliance manuals. However, the relevant Benchmark Logbook is still being included with all Thermal Storage products and unvented cylinders.

Gledhill fully supports the Benchmark aims to improve the standards of installation and commissioning of central heating systems in the UK and to encourage the regular servicing of all central heating systems to ensure safety and efficiency.

Building Regulations require that the heating installation should comply with the manufacturer's instructions. It is therefore important that the commissioning check list is completed by the competent installer. This check list only applies to installations in dwellings or some related structures.

**d) If sealed components in the appliance are replaced and/or re-commissioned in the field then these must be done strictly in accordance with manufacturer's instructions and these components must be re-sealed.**

## 5. Continuous Improvements

In the interest of continuously improving the GulfStream<sup>A-CLASS</sup> range, Gledhill Water Storage Ltd reserves the right to modify the product without notice and in these circumstances this booklet which is accurate at the time of printing should be disregarded.

	Page
<b>1. INTRODUCTION</b>	4
1.1. OPERATION	4
1.2. FLUEING OPTIONS	5
1.3. OPTIONAL EQUIPMENT	6
1.4. MODEL SELECTION GUIDE	7
1.5. GAS SUPPLY	7
1.6. ELECTRICITY SUPPLY	7
1.7. APPLIANCE LOCATION	7
<b>2. TECHNICAL DATA</b>	8
2.1. PHYSICAL DATA	9
2.2. HOT WATER PERFORMANCE DATA	10
2.3. SPACE HEATING PERFORMANCE	10
<b>3. SYSTEM DESIGN</b>	11
3.1. VENTILATION REQUIREMENTS	11
3.2. HOT AND COLD WATER SYSTEM	11
3.3. SPACE HEATING SYSTEM DESIGN	13
3.4. FLUE SYSTEM DESIGN	16
<b>4. INSTALLATION AND WIRING</b>	17
4.1. FITTING THE APPLIANCE	17
4.2. ELECTRICAL WIRING	19
<b>5. COMMISSIONING</b>	23
5.1. INITIAL SYSTEM FILLING	23
5.2. PRELIMINARY ELECTRICAL AND GAS SYSTEM CHECKS	23
5.3. CLEANSING AND WATER TREATMENT	24
5.4. FLUE SYSTEM	24
5.5. CONTROL PANEL DISPLAY AND DIAGNOSTICS	25
5.6. INITIAL LIGHTING	27
5.7. CENTRAL HEATING SYSTEM	29
5.8. DOMESTIC HOT WATER SYSTEM	29
5.9. HANDOVER TO THE USER	29
<b>6. ROUTINE ANNUAL SERVICE</b>	30
6.1. BURNER, GAS VALVE, VENTURI & FAN SUB-ASSEMBLY	30
6.2. CLEANING THE HEAT EXCHANGER	30
6.3. CLEANING THE CONDENSATE TRAP	30
6.4. POWER FLUSHING/CLEANING THE HEAT EXCHANGER	30
<b>7. SERVICING AND CHANGING COMPONENTS</b>	32
<b>8. PARTS LIST</b>	36
<b>9. APPENDIX A WATER SAVINGS</b>	39
<b>10. APPENDIX B INHIBITOR / SCALE PROTECTION</b>	40
<b>11. MANUAL HANDLING OF APPLIANCE</b>	41
<b>12. GAS BOILER COMMISSIONING CHECKLIST</b>	42
<b>13. TERMS AND CONDITIONS OF TRADING</b>	46



*The code of practice for the installation,  
commissioning & servicing of central heating systems*

Gledhill Water Storage Limited  
Sycamore Estate  
Squires Gate  
BLACKPOOL  
Lancs  
FY4 3RL

# INTRODUCTION

## 1 INTRODUCTION

GulfStream<sup>A-CLASS</sup> is a room sealed gas fired fan flued condensing boiler with an integrated store for space heating and domestic hot water. The appliance incorporates a primary store for producing mains pressure hot water. All models meet the essential requirements of the European Gas Appliance Directive 90/396/EEC and are WRAS listed.

All models in the GulfStream<sup>A-CLASS</sup> range are supplied with an integrated 9kW electric boiler for space heating and domestic hot water in the event of a failure on the gas side.

The operation is automatic and the fully modulating pre-mixed burner ensures that the gas is burned efficiently and cleanly (< 17ppm NO<sub>x</sub> Class 5) within the condensing heat exchanger. The advanced integrated control system includes monitoring of all safety features and diagnostics.

An important feature of this design is that domestic hot water can be supplied directly from the mains without the need for additional safety controls in the domestic hot water (DHW) supply. This is achieved by passing the mains water through a plate heat exchanger which is heated instantaneously by the preheated primary water from the store. The domestic hot water outlet temperature is maintained at about 52°C by the appliance controller which regulates the speed of the pump circulating the primary hot water from the thermal store through the primary side of the plate heat exchanger.

The Building Regulations L1A: New dwellings/L1B: Existing dwellings and the requirements set out in the Domestic Heating Compliance Guide specify that "where the mains water hardness exceeds 200ppm provision should be made to treat the feed water to water heaters and the hot water circuit of combination boilers to reduce the rate of accumulation of lime scale"

To comply with this requirement the hardness of the mains water should be checked by the installer and if necessary the optional factory fitted in-line scale inhibitor should be specified at the time of order for hardness levels between 200 and 300 ppm (mg/l).

Where the water is very hard ie 300ppm (mg/l) and above the optional polyphosphate type, inhibitor should be specified at the time of order. However, this will need to be fitted by the installer at a suitable point in the cold water supply to the appliance.

The '-OV' models (figure 1.1) are suitable for open vented heating systems only and the '-SS' models (figure 1.2) are suitable for sealed heating systems only.

### 1.1 OPERATION

The appliance control works on the principle of "hot water priority" and the hot water store is directly heated. Therefore although the central heating output may be temporarily interrupted if the store temperature falls below the pre-set value, the heating off-period will be very short (usually less than 6 minutes). The hydraulic and component arrangements of the open vented and the sealed system models are shown schematically in figures 1.3 and 1.4 respectively.

To suit conventional radiator based central heating systems, the appliance will normally provide flow temperature of about 82°C. The appliance controls will automatically responds to lower central heating and hot water demands by modulating the burner i.e. reducing the heat output which also decreases wasteful on-off cycling.

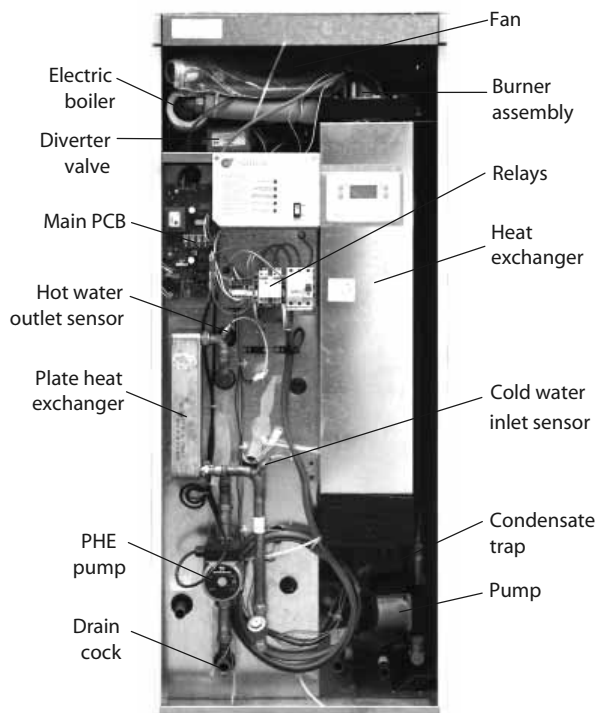

Figure 1.1 Open Vented GulfStream<sup>A-CLASS</sup>

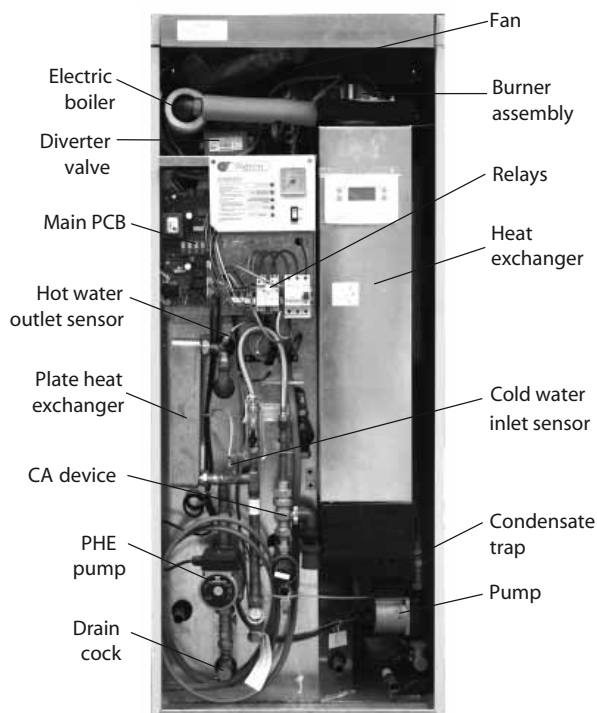

Figure 1.2 Sealed System GulfStream<sup>A-CLASS</sup>

# INTRODUCTION

The GulfStream<sup>A-CLASS</sup> is supplied complete with a 2 channel factory fitted programmer for control of heating and hot water. However, provision is also made for fitting separate controls if needed to suit a multi zone heating system. In this case the model with 'no' clock option should be ordered. The appliance has its own built in frost protection which will prevent the appliance temperature dropping below about 5°C.

The appliance is fitted with a 9kW electric backup boiler in the event a gas boiler fails. The user has the option of selecting and operating the heating and hot water system with this backup system until the gas boiler functioning is restored.

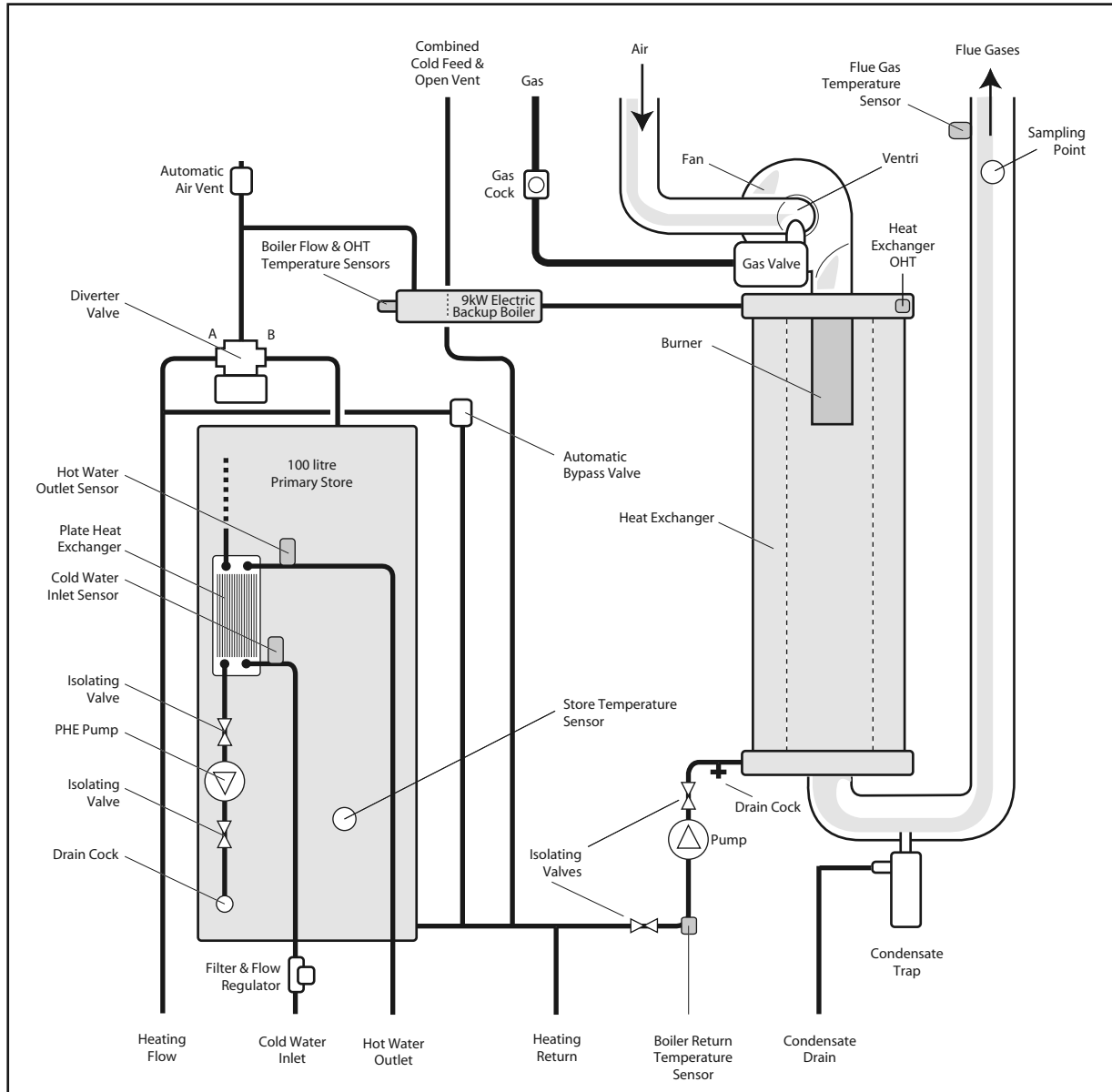

Fig 1.3 Schematic diagram of the open vented model of GulfStream<sup>A-CLASS</sup>

## 1.2 FLUEING OPTIONS

The small diameter twin pipe flue system has been designed for lengths up to 30m. The air intake and flue discharge pipes are connected to sockets positioned top-rear of the GulfStream. From this point, they may be run in any direction sanctioned within this literature. The flue options are: -

### 1.2.1 Ridge terminal flue kit

This unbalanced ridge terminal flue system comprises a number of push fit socketed concentric and single pipe components and is designed to allow air to be taken from the ventilated roof space and the flue gases to be discharged to atmosphere through a suitable ridge tile terminal.

### 1.2.2 Gable terminal flue kit

This unbalanced flue system comprises a number of push fit socketed concentric and single pipe components and is designed to allow air to be taken from the ventilated roof space and the flue gases to be discharged to atmosphere through a gable wall terminal.

# INTRODUCTION

## 1.2.3 Balanced flue terminal kit

The balanced flue kit comprises a number of push fit socketed concentric components and is designed to allow the appliance to be fitted internally on an outside wall with air intake and flue gas outlet discharged to atmosphere through a suitable concentric terminal. This arrangement is suitable for rear, left or right hand discharge.

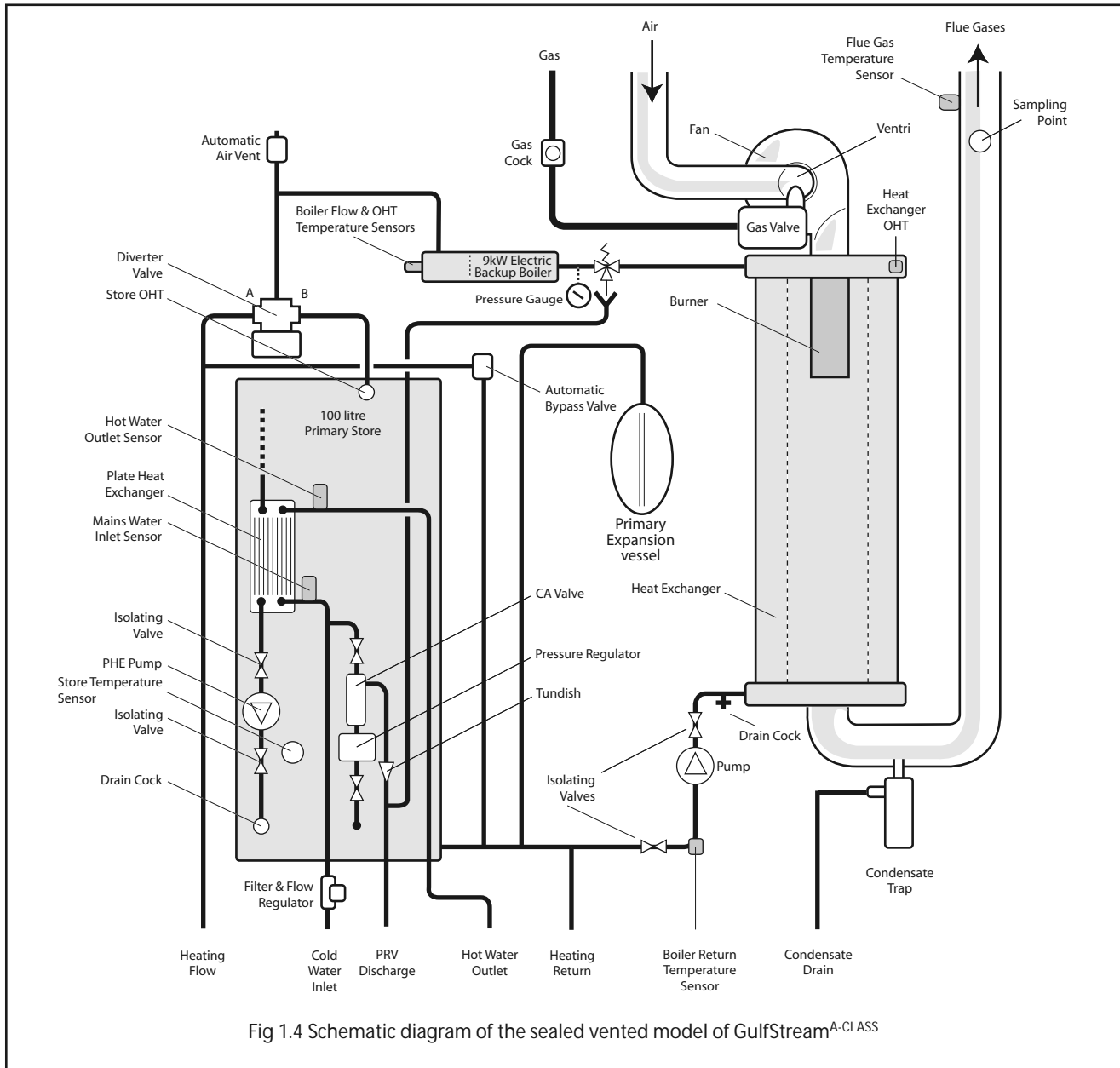

Fig 1.4 Schematic diagram of the sealed vented model of GulfStream<sup>A-CLASS</sup>

## 1.2.4 Twin pipe horizontal flue kit

The balanced twin pipe flue system comprises a number of push fit socketed concentric and single pipe components. It is designed to allow the installation of flues within ceiling voids, or ducts, in apartments with fresh air and flue exhaust being provided from concentric wall terminal built into the external wall.

## 1.2.5 Roof terminal flue kit

The balanced flue roof terminal flue system comprises a number of push fit socketed concentric components and it is designed to allow air and flue gases to be discharged to atmosphere through a suitable concentric roof terminal. Pitched and flat roof options are both available.

## 1.3 OPTIONAL EQUIPMENT

- Flexible hose connection kit. For further details see Installation & Wiring section of this manual.
- Grundfos UPR 15-60 modulating pump for larger space heating systems.

**Table 1.1: Model Selection Guide**

	OV and SS Model		
	12	20	30
<b>Overall dimensions (mm)</b>			
Height	1450	1450	1450
Width	595	595	595
Depth	595	595	595
<b>Weight (kg)</b>			
Empty/Full - OV models	88/188	88/188	88/188
Empty/Full - SS models	104/204	104/204	104/204
<b>Maximum dwelling heat loss</b>	10.0	18.0	26.0
<b>Property Selection Guide</b>			
Bedrooms	1-3	2-4	3-6
Bathrooms	1	1	2 1
En-Suite showers	1	2	1 3

## 1.4 MODEL SELECTION GUIDE

General selection criterion is shown in table 1.1. However before selecting the model, the space heating and hot water requirements of the dwelling are correctly assessed. If the appliance is to be installed in a cupboard, then the minimum dimensions and clearances specified in section 2.1 (figure 2.1 and table 2.1) must be observed.

## 1.5 GAS SUPPLY

(a) The Local Gas Supplier should be consulted at the installation planning stage in order to establish the availability of an adequate supply of gas.

(b) An existing service pipe **MUST NOT** be used without prior consultations with the gas supplier.

(c) A gas meter can only be connected by the Local Gas Supplier or by his Contractor.

(d) An existing meter should be of sufficient size to carry out the maximum boiler input plus the demand of any other installed gas appliance, (BS 6891:1988). See section Technical Data (Table 3) for the gas required for each specific model.

(e) A minimum of 22mm diameter pipe work must be used up to at least 500mm from the appliance gas cock.

(f) The governor at the gas meter must give a constant outlet pressure of 20mbar when the appliance is running.

(g) The gas supply line must be purged. **WARNING:** before purging open all doors and windows and also extinguish any cigarettes, pipes and any other naked lights.

(h) The complete gas installation must be tested.

## 1.6 ELECTRICITY SUPPLY

(a) The mains supply required is 230V~, 50Hz, 45A because all GulfStream<sup>A-CLASS</sup> models have a 9kW electric backup boiler. However the gas boiler/control and electric boiler circuits are internally fused separately. Minimum external fuse rating and the mains supply cable rating are given in "Electrical Wiring" section of this manual. All fuses must be ASTA approved to BS 1362. This appliance **MUST BE EARTHED**.

(b) All external wiring to the boiler must be in accordance with the latest I.E.E. Wiring Regulation, and any local regulations which may apply.

(c) There must be only one common isolator for the boiler and its control system, and it must provide complete electrical isolation via a fused double pole isolator with a contact separation of at least 3mm in both poles.

(d) In the event of an electrical fault after installation of the appliance, preliminary electrical checks must be carried out i.e. Earth Continuity, Short Circuit, Polarity, and Resistance to Earth.

## 1.7 APPLIANCE LOCATION

(a) GulfStream<sup>A-CLASS</sup> is room sealed and therefore can be located in any room/compartment in a domestic property. Although the appliance is essentially quiet, it does incorporate a fan and pumps. Therefore the chosen position should bear this in mind and not be the one which is particularly sensitive to noise.

(b) The boiler is **NOT** suitable for external installation. The position selected for installation should be within the building, unless otherwise protected by a suitable enclosure, and **MUST** allow adequate space for installation, servicing, and operation of the appliance and for air circulation around it.

(c) The installation position **MUST** allow for the flue and air inlet system to be fitted in correct position as per installation manual(s).

(d) The boiler must be installed on a flat surface, which is capable of supporting the weight of the appliance and any other ancillary equipment.

# TECHNICAL DATA

- (e) If the boiler is to be fitted in a timber framed building, it should be fitted in accordance with the British Gas publication "Guide for Gas Installations in Timber Frame Housing, Reference IGE/UP/7:1998". If in doubt, advice must be sought from the Local Gas Supplier.
- (f) A compartment used to enclose the appliance MUST be designed and constructed specifically for this purpose. An existing cupboard or compartment may be used provided it is modified accordingly. BS6798 gives details of the essential features of cupboard/compartment design, including airing cupboards.
- (g) It is recommended to put some sound deadening material (e.g. felt) between the boiler and the floor to absorb any vibration from the pumps and fan.

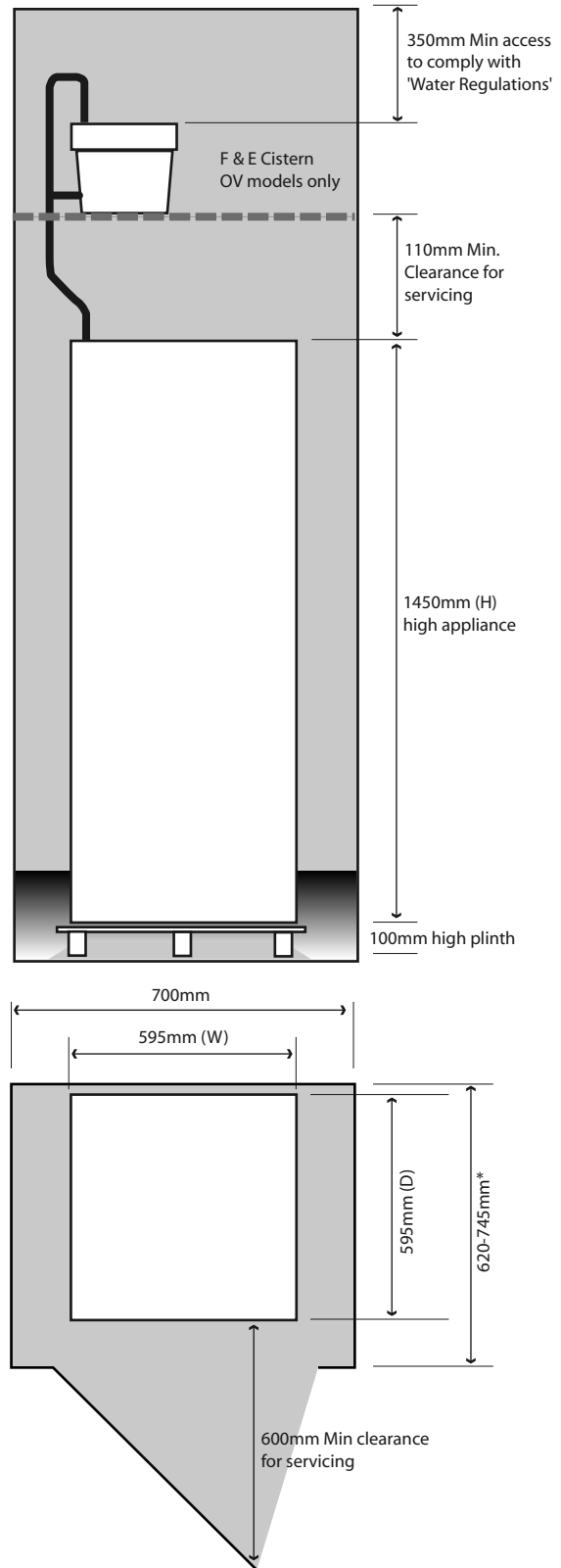

## 2 TECHNICAL DATA

Table 2.1 Clearances and cupboard sizes	
Overall dimensions - All models (mm)	
Height (H)	1490
Width (W)	595
Depth (D)	595
Service & installation clearances (mm)	
Top OV Models	110 <sup>(1)</sup>
Top SS Models	300
Rear - depending upon flue type	5
Left hand side (from door frame)	5
Right hand side (from door frame)	5
Front (unless door opens)	Nil
Base - appliance on a plinth	
Minimum cupboard dimensions (mm)	
Width - All models	700
Depth - All models	620 - 745 <sup>(2)</sup>
Height OV models	2,310 <sup>(3)</sup>
Height SS models	1850
Pipe connections	
Heating flow & return - copper pipe	22mm
Cold water inlet - copper	22mm
Hot water outlet - compression	22mm
Gas inlet - Gas union valve	R1/2"
Condensate drain - plastic pipe	22mm
Cold feed & open vent - copper pipe	22mm
Pressure relief valve - copper pipe	22mm
<b>Notes:</b>	
<b>(1)</b> If F&E cistern is located in the same cupboard. If not the minimum access required is 300mm; same as the SS models.	
<b>(2)</b> Depending upon the flue system used.	
<b>(3)</b> Assumes that the appliance is installed on a plinth and the feed and expansion cistern is installed in the same cupboard.	

Figure 2.1 Clearances and cupboard dimensions



# TECHNICAL DATA

All models have integral 9kW electric boiler for emergency backup for space heating and hot water. Therefore although these appliances are internally fused at 6A for the gas boiler circuit, a 230V ~, 50Hz electricity supply fused at 45A is required direct from the consumer unit via a 45A double pole local isolator.

## 2.1 Physical DATA

The physical characteristics and the clearances required for installing the appliance in a cupboard are shown in figure 2.1 and table 2.1. The 170mm clearance at the top for the open vented models is based on the assumption that the F&E cistern is located in the same cupboard as shown schematically in figure 2.1. If the F&E cistern is located elsewhere, the minimum clearance required at the top is 300mm i.e. same as for the '-SS' models. The minimum opening of the cupboard door (measured between the door stops) must be at least 605mm.

The connection details of the appliance are given in figure 2.5

Table 2.2 Performance Data						
	GS <sup>A</sup> -CLASS 12 OV & SS		GS <sup>A</sup> -CLASS 20 OV & SS		GS <sup>A</sup> -CLASS 30 OV & SS	
Maximum heat output - Condensing (kW)	12.8		21.0		31.0	
Maximum heat output - Non condensing (kW)	11.6		19.3		28.8	
Minimum heat output - Condensing (kW)	10.7		10.7		10.7	
Minimum heat output - Non condensing (kW)	9.7		9.7		9.7	
Maximum GROSS heat input (kW)	13.3		22.2		33.3	
Maximum NET heat input (kW)	12.0		20.0		30.0	
Minimum GROSS heat input (kW)	11.10		11.10		11.10	
Minimum NET heat input (kW)	10.00		10.00		10.00	
Maximum gas rate (m <sup>3</sup> /h)	1.27		2.11		3.17	
Minimum gas rate (m <sup>3</sup> /h)	1.06		1.06		1.06	
Flue gases maximum flow rate (gm/s)	5.8		9.4		14.0	
NO <sub>x</sub> (mg/kWh)	Class 5 to BS EN 483		Class 5 to BS EN 483		Class 5 to BS EN 483	
CO (mg/kWh)	<75mg/kWh		<75mg/kWh		<75mg/kWh	
Burner offset pressure (Pa)	-18 to -20		-18 to -20		-18 to -20	
Electrical Supply via double pole 45 A isolator	230 ~ 50hz 45A fused		230 ~ 50hz 45A fused		230 ~ 50hz 45A fused	
Power consumption @ 230V 50Hz (W)						
Minimum in standby mode	10		10		10	
Maximum in running mode with gas boiler operating	205		216		248	
Maximum in running mode with electric boiler operating	8,990		8,990		8,990	
Losses from store 70°C (W)	60		60		60	
<b>Hot water performance (figure 2.2)</b>						
Min. flow rate at approx 55°C (l/min)	2.0		2.0		2.0	
Max flow rate at 35°C temperature rise (l/min)	24		24		35	
Specific flow rate 35°C temperature rise (l/min)	8.5		16.0		24.5	
Min inlet pressure for nominal flow rate (bar)	2.0		2.0		2.0	
Maximum inlet water pressure (bar)	10.0		10.0		10.0	
Maximum recommended inlet water pressure (bar)	3.5		3.5		3.5	
Nominal hot water temperature set point (°C) @ 18 l/min	55± 2°C		55± 2°C		55± 2°C	
	OV	SS	OV	SS	OV	SS
<b>Central heating circuit characteristics</b>						
Maximum stored water temperature (°C)	82	82	82	82	82	82
Nominal heating flow temperature (°C)	82	82	82	82	82	82
Minimum water pressure (bar)	---	1.0	---	1.0	---	1.0
Maximum water pressure (bar)	1.0	2.5	1.0	2.5	1.0	2.5
Expansion relief valve setting (bar)	---	3.0	---	3.0	---	3.0
Expansion vessel volume (l)	---	16	---	16	---	16
<b>Connections (See figure 2.5)</b>						
Heating flow and return	22mm copper pipe					
Cold water (mains) inlet	22mm compression					
Hot water outlet	22mm copper pipe					
Condensate discharge	22mm OD flexible plastic pipe					
Pressure relief / Tundish (copper pipe)	---	22mm	---	22mm	---	22mm
Open vent	22mm	---	22mm	---	22mm	---

# TECHNICAL DATA

**Figure 2.2 Hot water performance of GulfStream<sup>A-CLASS</sup> models**  
(Volumes for 35°C temperature rise and 10°C mains inlet temperature)

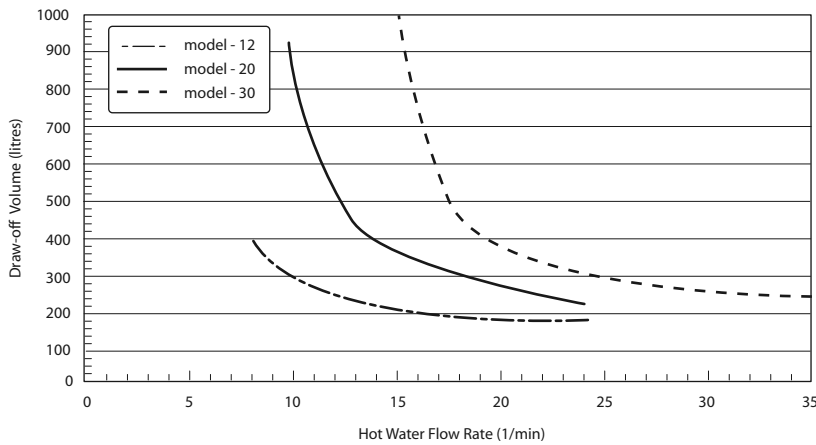

## 2.2 HOT WATER PERFORMANCE

This appliance has hot water priority control logic and the hot water storage vessel is directly heated by the boiler and therefore full boiler output is used for heating hot water resulting in very short recovery times. Typical recovery times for raising the stored water temperature by 45°C for models '-12', '-20', '-30' are 25, 15 and 10 minutes respectively.

The hot water performance of the appliance is shown in figure 2.2. The flow rates and the corresponding maximum hot water volumes drawn off and quoted in table 2.2 and figure 2.2 assume adequate dynamic pressure and flow to property and the store is charged to design temperature of 75°C.

The mixed flow temperature will provide a 35°C rise when water is drawn off at up to 24 l/min for the '12' and '20' and 35 l/min for the '30' as shown in figure 2.2 provided the maximum water volume is not exceeded. At nominal 35°C temperature rise, the maximum hot water production of the models '-12', '-20' and '-30' is 400, 560 and 770 litres per hour respectively.

In practice the '12' and '20' models are fitted with an 18 l/min flow regulator and the '30' model with a 26 l/min regulator which will allow them to deliver hot water at the design temperature of 55°C ± 2°C.

## 2.3 SPACE HEATING PERFORMANCE

All models modulate down to about 10kW heat output without burner cycling and if the demand is below this level, the burner will cycle to match the heat demand.

GulfStream<sup>A-CLASS</sup> has 'hot water priority' controls and therefore full boiler output is available for space heating i.e. no allowance is necessary for domestic hot water load when selecting the appliance.

All GulfStream<sup>A-CLASS</sup> models are fitted with Grundfos UPR 15-50 modulating pumps as standard. The net pump head available for space heating circuit is shown below in figure 2.3.

All models are factory fitted with an automatic bypass valve and is factory set to operate at a differential pressure of 2.5m head.

For optimum performance, this valve must be set during commissioning to suit the heating system. The characteristic of the automatic bypass valve is shown in figure 2.4.

**Figure 2.3 Space Heating Pump Characteristics of GulfStream<sup>A-CLASS</sup>**

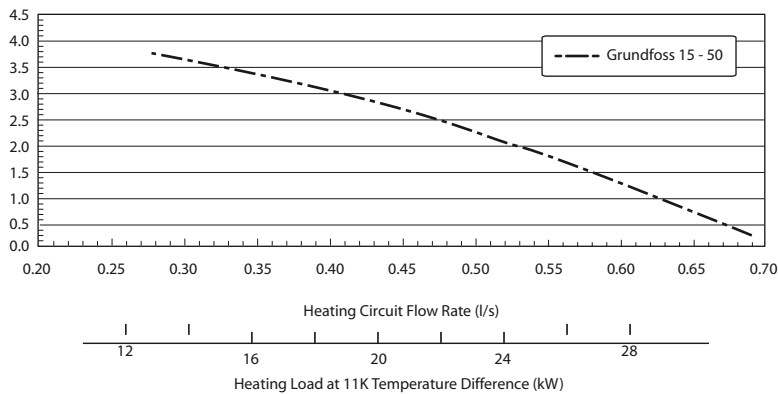

**Figure 2.4 Characteristics of the automatic bypass valve**

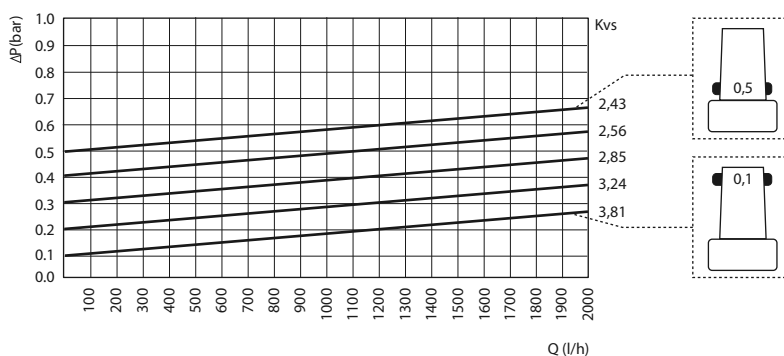

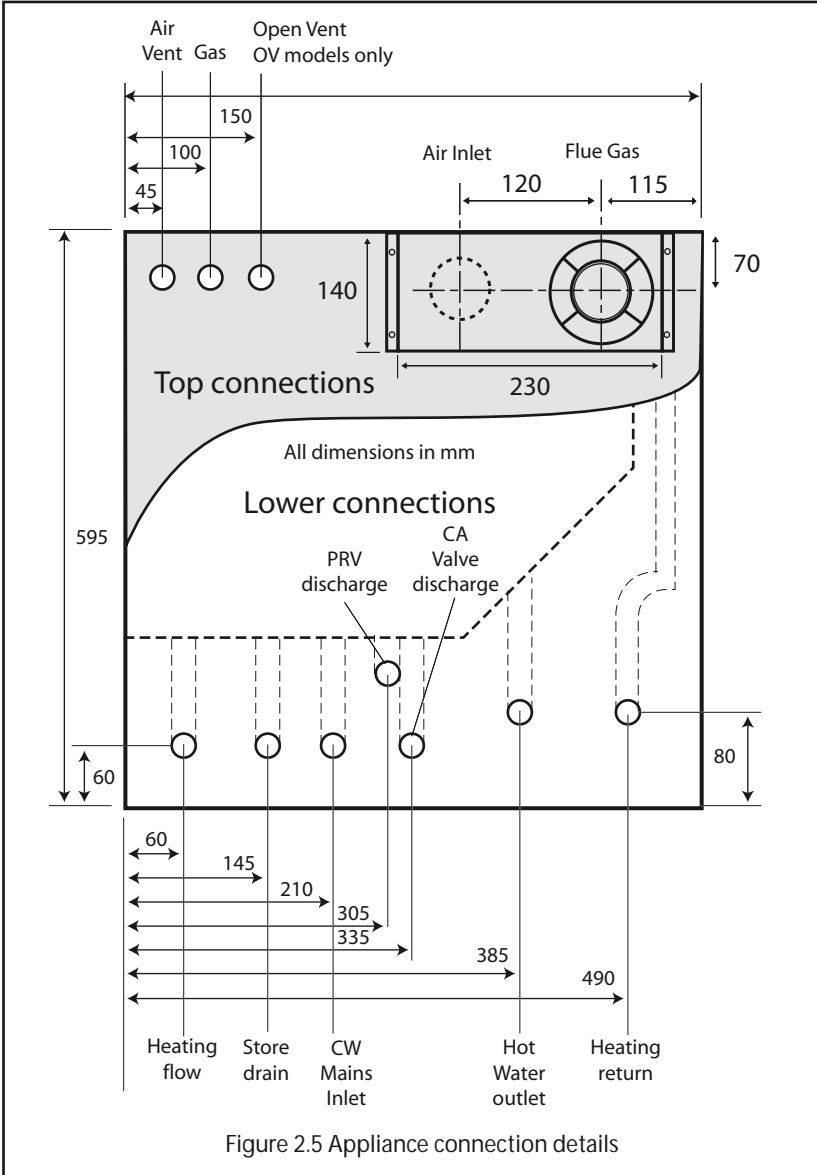

Figure 2.5 Appliance connection details

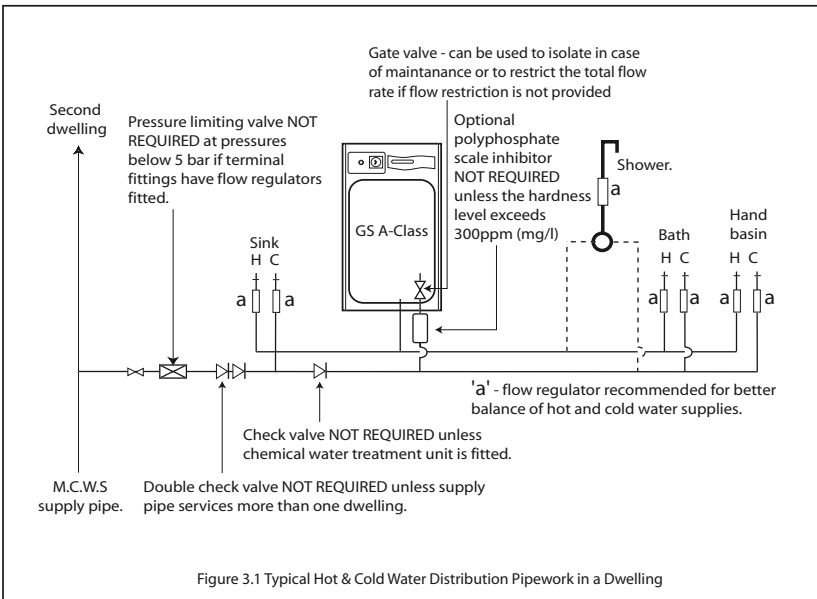

Figure 3.1 Typical Hot & Cold Water Distribution Pipework in a Dwelling

### 3.1 VENTILATION

(a) The GulfStream<sup>A-CLASS</sup> is a room sealed appliance and therefore it does not take air for combustion from the dwelling. Therefore when this room sealed appliance is installed in a room or habitable internal space, there are no specific ventilation requirements.

Position of opening	Ventilated to	Area of each vent (cm <sup>2</sup> )
High and low level	Room	80
High and low level	Outside	40

(b) When the appliance is installed in an airing cupboard of minimum dimensions specified in section 1.7 (table 2.1 and figure 2.1) no vents are required in the airing cupboard. The normal infiltration rate through the cupboard is sufficient to provide cooling air for the appliance.

(c) When the appliance is installed in a purpose built boiler compartment it is essential that permanent high and low level vents are provided for the circulation of cooling air. Purpose made vents must have a non-adjustable free area not less than the minimum specified in table 3.1.

### 3.2 HOT AND COLD WATER SYSTEM

(a) All recommendations with regard to pipe work systems in this manual are generally based on the use of BS/EN Standard copper pipework and fittings.

(b) However the plastic pipework system can be used in place of copper internally as long as the chosen system is recommended by the manufacturer for use in cold and hot water systems and is fully designed and installed in accordance with their recommendations.

(c) This is particularly important in relation to use of push fit connections when using the optional flexible hose kits (See Installation and Wiring section of this document).

(d) It is also important that if an alternative pipework material or system is chosen, then, the manufacturer confirms that the design criterion for the new system is at least equivalent to the use of BS/EN Standard copper pipework and fittings.

# SYSTEM DESIGN

## 3.2.1 Mains pressure and water supply

- (a) GulfStream<sup>A-CLASS</sup> is designed to be connected directly to the mains and fulfill the requirements of Water Byelaw 91 and therefore do not require a check valve to be fitted to the supply pipe. However should ancillary equipment requiring a non-return valve be fitted to the same mains supply as the GulfStream, then this valve must not be fitted between the inlet of this mains supply to the property and the GulfStream (see figure 3.1).
- (b) The hot water flow rate achievable from the GulfStream<sup>A-CLASS</sup> and the performance of the domestic hot and cold water systems is directly related to the adequacy of the cold water mains serving the property. For this reason the cold water supply to the dwelling must be capable of providing for those services which could be required simultaneously and this maximum demand should be calculated. Also if a water meter is fitted its nominal rating should match the anticipated maximum simultaneous hot and cold water demand calculated in accordance with BS 6700. This could be 50 litres per minute in some properties.
- (c) The GulfStream<sup>A-CLASS-OV</sup> models will operate at pressure as low as 1 bar but the recommended range is between 2 and 3 bar. These pressures must be dynamic and be available at the appliance when local demand is at its maximum.
- (d) The GulfStream<sup>A-CLASS-SS</sup> models are fitted with an automatic filling device which charges the system to 1.0 bar and for this to work correctly; a recommended dynamic pressure of between 2-3 bar **must** be available to the appliance at all times.
- (e) As a general guideline, although a 15mm service may be sufficient for smaller dwellings with one bathroom, a 22mm service (25mm MDPE) is preferred and should be the minimum for larger dwellings.
- (f) If the incoming mains pressure exceeds 5 bar at any time in a 24 hour cycle, then, a pressure regulating valve set at 3.5 bar should be fitted down stream of the stop tap where the cold supply enters the property.
- (g) Equipment used in the system should be suitable for a working pressure of up to 5 bar.

## 3.2.2 Use in Hard Water Areas

The Building Regulations L1A: New dwellings/L1B: Existing dwellings and the requirements set out in the Domestic Heating Compliance Guide specify that "where the mains water hardness exceeds 200ppm provision should be made to treat the feed water to water heaters and the hot water circuit of combination boilers to reduce the rate of accumulation of lime scale"

To comply with this requirement the hardness of the mains water should be checked by the installer and if necessary the optional factory fitted in-line scale inhibitor should be specified at the time of order for hardness levels between 200 and 300 ppm (mg/l).

Where the water is very hard ie 300ppm (mg/l) and above the optional polyphosphate type, inhibitor should be specified at the time of order. However, this will need to be fitted by the installer at a suitable point in the cold water supply to the appliance.

## 3.2.3 Cold and hot water distribution network

- (a) As a minimum, it is recommended that the cold supply to the appliance internally is run in 22mm copper or equivalent in plastic and then from the appliance in 22mm past the hot water draw-off to the bath .

- (b) We would recommend that the best results for a balanced system are achieved by fitting appropriate flow restrictors to each hot and cold water outlets. These must be fitted in cases where the final branch pipe sizes are not as recommended in (c) below or the water pressures are above the recommended 2 – 3 bar range. See appendix A for details of suitable flow regulators.
- (c) Alternatively the tee-offs to the outlets should be in 10mm except for bath and shower, which should be in 15mm (1 meter minimum length).
- (d) The hot water supply to a shower-mixing valve should be the first draw-off point on the circuit. The cold water supply to a shower-mixing valve should be fed directly from the rising main and should be the first draw off point on the cold water circuit.
- (e) It is important that the cold water pipe work is adequately separated from any heating/hot water pipe work to ensure that the water remains cold and of drinking water quality.

## 3.2.4 Taps and Shower Fittings

- (a) Ensure that all terminal fittings are suitable for mains pressure. Use aerated taps whenever possible to prevent splashing.
- (b) Any shower mixing valve used must be suitable for mains fed hot and cold supplies. However all mains pressure water systems are subject to dynamic changes particularly when other hot and cold water taps are opened and closed. For this reason, a thermostatic shower **MUST** be used with this appliance.
- (c) Note that the shower fittings must comply with the backflow prevention requirements (Para 15, Schedule 2) of the Water Supply Regulations 1999.
- (d) A bidet can be supplied from the GulfStream<sup>A-CLASS</sup> appliance as long as it is of the over rim flushing type and incorporates a suitable air gap.

## 3.2.5 Dead leg volumes

This appliance is not suitable for a secondary circulation system.

If the dead leg volumes of the hot water draw-off pipework is excessive and the delivery time will be more than 60 seconds before hot water is available at the tap, you may consider using trace heating such as the 'RaychemHWAT' system. Please call Gledhill technical department for further details.

## 3.3 SPACE HEATING SYSTEM DESIGN

### 3.3.1 General

- (a) **All GulfStream<sup>A-CLASS</sup>** models are available for both the sealed and the open vented heating systems and this is discussed below in sections 3.3.2 and 3.3.3.
- (b) **Appliance selection:** We recommend that the method for heat loss calculations, radiator and boiler sizing contained in BS 5449:1990 is used and then compared to data in table 1.1 for selecting the appropriate model. The allowance for hot water is built in and therefore no additional hot water allowance should be added to the calculated requirement for space heating.
- (c) **Design:** The installation must comply with the requirements of BS 6798 and BS 5449. To suit conventional radiator based central heating systems, the appliance will normally provide flow temperature of  $82 \pm 2^\circ\text{C}$ . Therefore normal procedures for sizing heating circuit network and radiators should be used.

The pump head available for heating circuit is shown in figure 2.3. The appliance is fitted with an automatic bypass valve, which is factory set to operate at a differential pressure of 2.4m head. Its characteristics are shown in figure 2.4. The appliance connection details are shown in figure 2.5.

If the appliance is at the highest point, automatic air vent is provided on the appliance. However if any point of the heating system is higher than the appliance, then an automatic air vent must be fitted at the highest point in the system.

At least one flushing point should be fitted at the lowest point in the system to enable the system water to be adequately flushed during commissioning.

*For low temperature heating systems e.g. under floor heating, the low flow temperature can be factory set or can be programmed by a Gledhill ATSM.*

- (d) **Frost protection:** The appliance has its own built in frost protection which will prevent the appliance temperature dropping below about  $5^\circ\text{C}$ . However, if it is necessary, to protect other parts of the system installed in unheated spaces (e.g. garage, outhouse and ventilated roof space), a frost thermostat(s) must be fitted and wired as shown in section 4.
- (e) **User controls:** The GulfStream<sup>A-CLASS</sup> is supplied with factory fitted and wired two channel programmer for programming the hot water and space heating on-off time periods. If required other user controls can be connected to the appliance as shown in section 4.

An automatic bypass valve is built into the appliance to allow thermostatic radiator valves (TRV's) to be fitted. To meet the requirements of Building Regulations for a boiler interlock it is recommended that the radiator in the area where the room thermostat is installed should be fitted with lock shield valves on both connections.

The bypass valve is set at the factory to 2.5m head but this should be adjusted on site by the installer to ensure that the temperature rise across the boiler is not greater than  $12^\circ\text{C}$  when the boiler is firing at its maximum rating.

- (f) **Plastic pipework:** All the recommendations with regard to pipework systems in this manual are generally based on use of BS/EN Standard copper pipework and fittings. However plastic pipework can be used in place of copper internally as long as it is recommended by the manufacturer and installed fully in accordance with their recommendations. We always recommend the barrier plastic pipework for these systems.

It is important that if the system is to be installed using plastic pipework then ensure that it is designed and sized for plastic pipework. This is particularly important in relation to use of push fit connections when using the optional flexible hose kits. (See Installation and Wiring section of this document).

# SYSTEM DESIGN

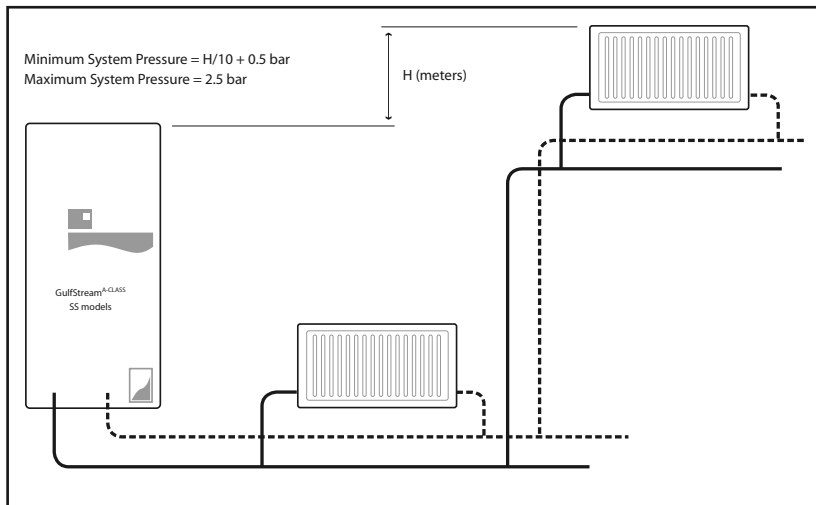

Figure 3.2 Schematic diagram of the sealed heating system

### 3.3.2 Sealed central heating system

(a) **Sealed System SS models:** These are suitable for sealed central heating systems shown schematically in figure 3.2 and are fitted with an automatic arrangement. Minimum of 2 bar mains pressure must always be available for correct operation of the CA device (figure 3.3) These models incorporate the following additional components:-

- 16 litre expansion vessel precharged to 1.0 bar.
- 0-4 bar pressure gauge
- Expansion relief valve - set to operate at 3.0 bar
- Automatic filling assembly incorporating CA type backflow prevention valve.
- Store overheat thermostat.

(b) **CA automatic filling device:** The automatic system filling arrangement incorporating CA type backflow prevention valve and pressure regulator replaces the normal system filling loop used with sealed heating systems and this will allow any loss of water from the heating system to be automatically replenished as with an open vented system fitted with a feed and expansion cistern.

CA automatic filling device and pressure regulating valve is set to fill the system to 1.0 bar. This is usually sufficient for the heating systems in most domestic properties. However the minimum system pressure should not be less than "0.5 + H/10" bar as shown in figure 3.2. The system filling pressure can be adjusted by the pressure regulator (see figure 3.3)

**Note:** If the system pressure is adjusted, then the expansion vessel charge pressure should be adjusted and the expansion vessel size must also be recalculated.

(c) **Expansion vessel:** The expansion vessel must accommodate the change in volume of system water heated from 10°C to 110°C (see BS 5449:1990 clause 16.2). When calculating the system water content, the capacity of the hot water store (100 litres) must be included. The expansion vessel requirements are shown in table 3.2

**Note:** After first filling the system to a pressure of 1.0 bar at mains supply temperature (typically 15°C in summer), the system (space heating and hot water) should be heated to its maximum temperature. If the pressure gauge indicates 2.6 bar or higher, then an additional expansion vessel may be required. Expansion vessel requirements are shown in table 3.2

(d) **Discharge pipe:** The discharge pipes from the system pressure relief valve and the CA valve are terminated into 2 individual tundish arrangements inside the appliance. These are combined to run in a 22mm minimum diameter discharge pipe which must have a continuous fall throughout its length. The discharge pipe details are shown in table 3.3 and figure 3.4

The discharge pipe should be terminated in a way that it permits safe discharge of hot water such that no hazard to persons or damage to property or electrical components is caused.

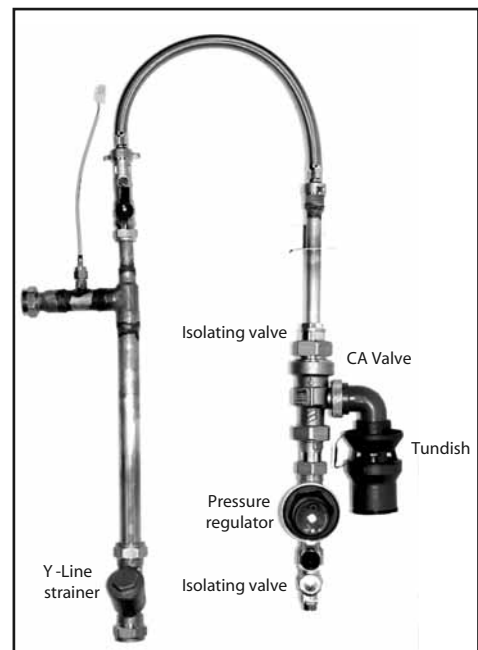

Figure 3.3 CA Filling device

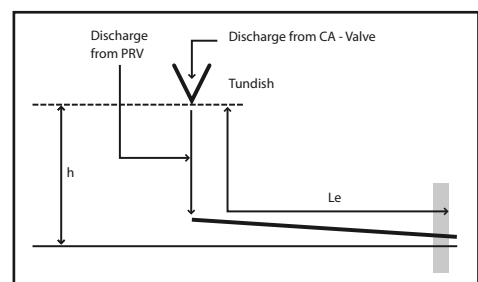

Figure 3.4 Tundish discharge pipe requirements

# SYSTEM DESIGN

**Table 3.2 Expansion vessel requirements**

Safety valve settings (bar)		3.0			
Initial vessel charge pressure (bar)		1.0		1.5	
Initial system pressure (bar)		1.0	1.5	1.5	2.0
Total water content of system (1)	Total water content of heating system (1)	Expansion vessel volume (litres)			
120	20	13.1	19.2	18.7	39.7
135	35	13.7	21.6	21.1	44.7
150	50	16.4	24.0	23.4	49.7
175	75	19.1	28.0	27.3	57.9
For other volumes multiply the system content by factor		0.109	0.190	0.156	0.331
Total system water content (1) = 100 + heating system water content (1)					

### 3.3.3 Open vented heating system

(a) **Open vented ('-OV') models** are only suitable for an open vented heating system shown schematically in figure 3.5.

(b) **F & E cistern:** The cistern supplied with the unit, can be fitted up to 10m above the base of the appliance i.e. the maximum static pressure in the appliance must not exceed 1.0 bar. The water level in the F & E cistern should be at least 250mm above the highest point on the system including the radiators.

(c) **Overflow pipe:** The overflow/warning pipe should be in 20mm internal diameter pipe of suitable material for use in heating systems in accordance with BS 5449 (such as copper). It should have continuous fall and discharge in a conspicuous external position. It should not have any other pipework directly branched into it.

**Cold feed and open vent:** This appliance uses combined cold feed and open vent. This should be run in 22mm copper pipe and connected to the Feed and Expansion cistern as shown in figure 3.5.

**Table 3.3: Discharge pipe sizes**

Height-h (m)	Pipe size (mm)	Maximum length- $L_e$ (m)
0.2	15	1
	22	9
	28	30
0.3	15	2
	22	13
	28	45
0.4	15	3
	22	19
	28	63
0.6	15	4
	22	27
	28	94
0.8	15	5
	22	27
	28	127
1.0	15	7
	22	46
	28	157

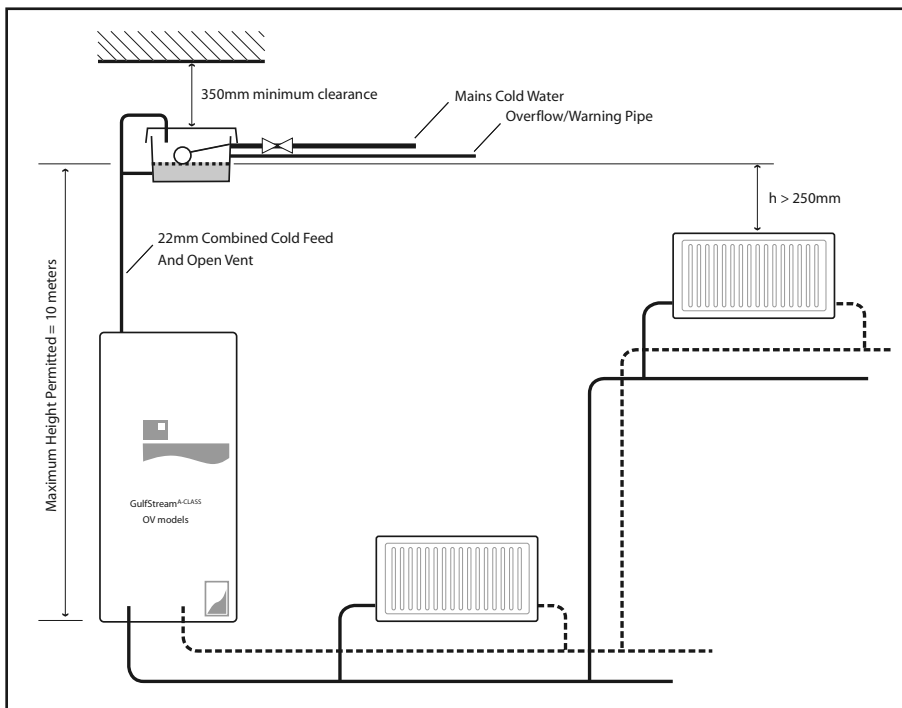

Figure 3.5 Schematic diagram of the open vented heating system

# SYSTEM DESIGN

## 3.4 FLUE SYSTEM DESIGN

A full range of flue options are available (figure 3.6) for the GulfStream<sup>A-CLASS</sup> and the details can be found in the following separate flue system design and installation manuals.

- 1) Ridge terminal flue kit
- 2) Gable terminal flue kit
- 3) Balanced flue terminal kit
- 4) Twin pipe horizontal flue kit
- 5) Roof terminal flue kit

**Note:** This appliance **must** only be installed using one of the above approved flue kits available only from Gledhill Water Storage Ltd and should be ordered with the appliance

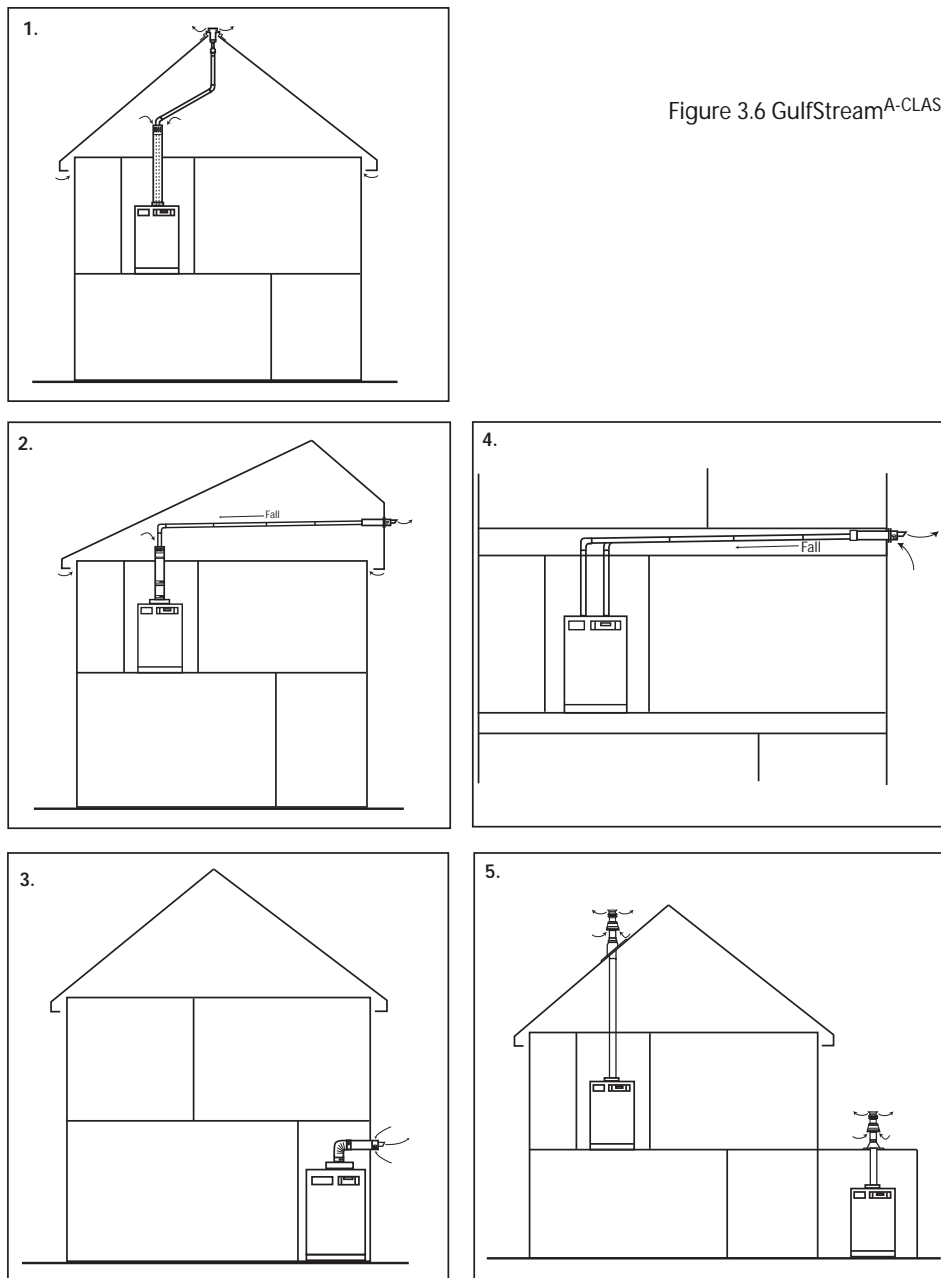

Figure 3.6 GulfStream<sup>A-CLASS</sup> flue options



# INSTALLATION AND WIRING

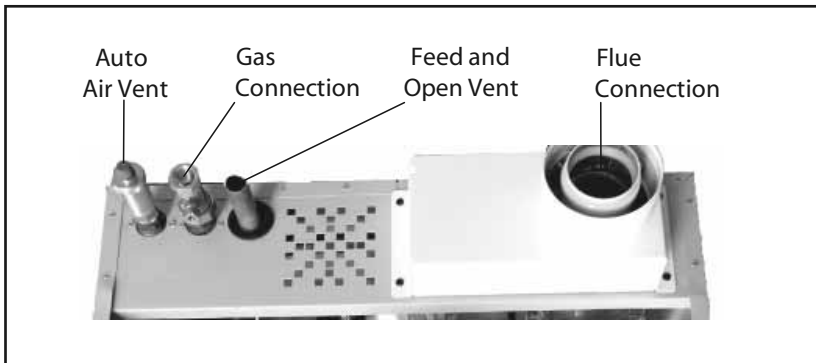

Figure 4.1 Connections at the top

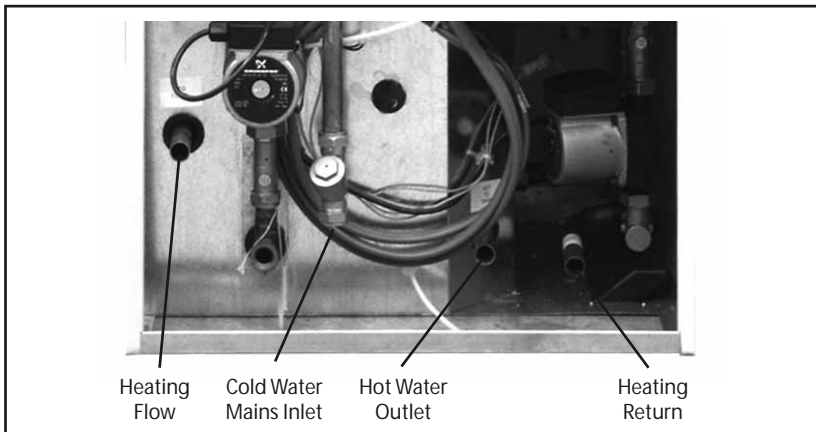

Figure 4.2 Open vented model connections

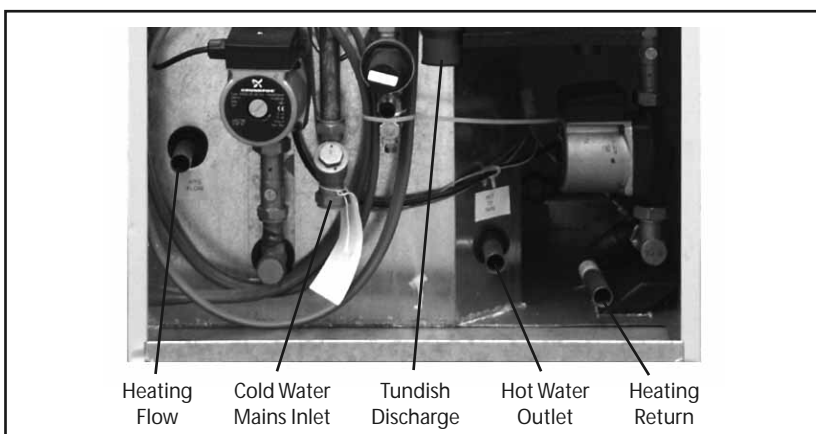

Figure 4.3 Sealed system model connections

## 4.1 FITTING THE APPLIANCE

### 4.1.1 General

- The appliance should be handled carefully to avoid damage and the recommended method is shown on page 2 of this manual.
- The appliance should be mounted on the 100mm high plinth supplied with the appliance to facilitate the pipework connections at the front of the appliance.
- When using push fit connectors with the flexible hose kits it is important to check that they are compatible. We currently recommend push fit connectors from the following manufacturers:

- Hepworth – Hep<sub>2</sub>O BITite
- John Guest – Speedfit
- Yorkshire – Tectite

The installer must check and confirm the suitability of any other types of push fit connectors.

- The gas connection, and on the OV model the combined cold feed and open vent connection are located at the top of the appliance. (See figures 3.3, 4.1, 4.2 and 4.3) All other connections are located at the bottom front of the appliance (figure 4.1).
- The appliance is supplied with 2 metre long 10mm<sup>2</sup> 3-core flexible cable for connecting to the fixed wiring in the dwelling. The fixed wiring to the appliance must incorporate a double pole isolator with at least 3mm contact separation at all poles. This 45A double pole isolator must be within 2m of the appliance and the appliance mains cable must be wired to this isolator.

### 4.1.2 Access to the Appliance

- Remove front panel by unscrewing the two screws on the left hand and right hand sides at the top of the appliance. Disengage the front panel from the top panel by lifting and pulling it forward at the top. Lift the front panel to disengage it from the bottom edge.
- The top panel can now be removed by gradually lifting it at the front and pulling it forward.

# INSTALLATION AND WIRING

## 4.1.3 Flue System

Only flue system supplied by Gledhill Water Storage Ltd for this appliance should be used. Unless already fitted, install the flue system as shown in the installation instructions supplied with the flue kit.

## 4.1.4 Gas Supply

- (a) Ensure that the gas supply is isolated.
- (b) The gas supply to the appliance should be in 22mm copper or equivalent steel pipe up to within 0.5 metre of the appliance gas cock.
- (c) The gas connection is made at the top of the appliance and the union gas cock is supplied as a loose item in the fitting kit. The male liner with the union nut should be fitted to the RC ½" gas inlet using an approved jointing compound. The gas cock can then be fitted and gas supply connected.
- (d) **DO NOT** turn on the gas supply or the appliance at this stage.

## 4.1.5 Central Heating and Domestic Hot Water Connection

- (a) The central heating flow and return connections are clearly labelled. Using 22mm copper pipework connect the appliance to the central heating system. Heating system isolating valves should be fitted as close as possible to the appliance.
- (b) The mains cold water supply and the domestic hot water outlet connections are clearly labelled. Using 22mm copper pipework connect the appliance to the mains supply and hot water supply network. Cold water mains supply isolating valve should be fitted as close as possible to the appliance.

## 4.1.6 Condensate Drain Pipe

- (a) Before fitting the condensate drain pipe, remove and fill the condensate trap with water and refit to the appliance..
- (b) The condensate will be slightly acidic and the condensate pipe should be run in a high temperature plastic drain pipe material (e.g. PP, UPVC etc). Copper tube **MUST NOT** be used and 'Push Fit' overflow pipe **MUST NOT** be used.
- (c) Internal pipework should have a bore diameter no smaller than 20mm.
- (d) The external pipework should be kept to minimum, and have a bore diameter no smaller than 32mm.
- (e) The pipe should not have any upward pipe runs and must fall at least 2.5° (1:20) throughout its length towards the discharge point.
- (f) **It is strongly recommended that the condensate pipe should be run internally to the house soil or vent stack or to a waste pipe.**
- (g) Alternatively the condensate may be discharged into a rainwater system, external gully or a purpose-built soakaway. Any local building control authority requirements must be complied with.
- (h) It is recommended that the pipe should not be installed externally but if it is it should be insulated and terminated below the grating level of the gully or at least 50mm above the soak away to minimise the effects of freezing.

## 4.1.7 Feed and Expansion Cistern (Open vented '-OV' models only)

- (a) The feed and expansion cistern should be installed on a level and flat base to ensure that it is fully supported.
- (b) The feed and expansion cistern should not rest on top of the appliance case. Adequate access must be provided for maintenance of the F & E cistern (See figure 2.1).
- (c) Connect the combined cold feed and open vent pipe in 22mm copper from the appliance to the cistern as shown schematically in figure 2.1.
- (d) Run the overflow/warning pipe in at least 20mm internal diameter pipe in material complying with BS 5449 (such as copper). It should have a continuous fall and discharge in a conspicuous external position with no other pipe connected to it.

## 4.1.8 Tundish discharge pipe (Sealed system '-SS' model only)

- (a) The pressure relief discharge is connected to the tundish discharge from the automatic CA filling device (figure 4.3).
- (b) The common discharge pipe should be run in copper with an internal diameter of at least 20mm and have a continuous fall of 0.25° (i.e. minimum 1:200).
- (c) The discharge must terminate in a way that it permits safe discharge of hot water such that no hazard to persons or damage to property or electrical components is caused.

# INSTALLATION AND WIRING

## 4.2 ELECTRICAL WIRING

The standard models are supplied with factory fitted two channel heating and hot water programmer. Therefore only a room thermostat is required to be supplied and wired to the appliance.

However, other system controls e.g. for multi zone systems or a programmable room thermostat can be connected to the appliance and for this, the appliance model with no clock option should be ordered.

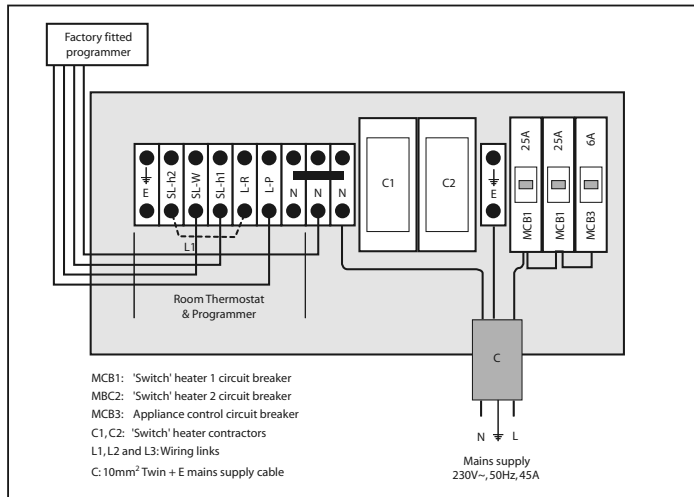

Figure 4.4A Appliance wiring panel with factory fitted Programmer

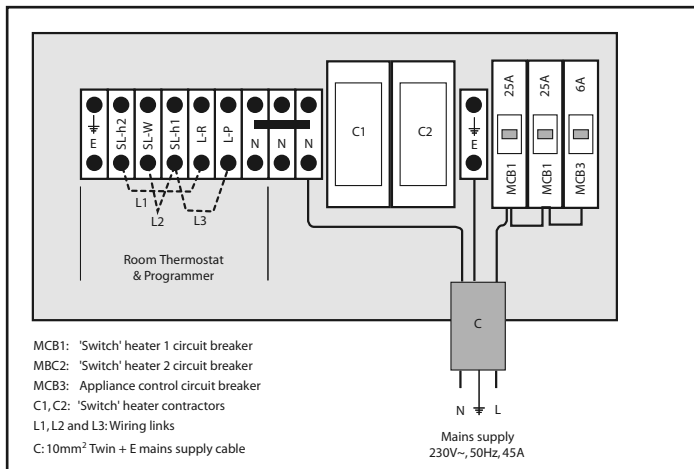

Figure 4.4B Appliance wiring panel with NO clock option

Table 4.4 Wiring specification and general guide for all models

Rating @ 230V - 50Hz <b>Note: All models are fitted with 9kW electric backup boiler</b>	9.0kW, 41.3A
Power consumption when gas boiler is operating @ 230V - 50Hz	Model 12: 205W, 0.9A Model 20: 216W, 1.0A Model 30: 248W 1.1A
Minimum rating of isolating switch	45A @ 250V ~ 50Hz
Maximum cable run based on a 9.2 volt drop & earth fault loop impedance for 0.4s disconnection time, when using type B protection device to BS EN 60898	10mm <sup>2</sup> cable: 45m
9.3kW appliance - Recommended circuit protection device (CPD) to ensure 0.4s disconnection time under fault conditions * Provides best protection	45A type 1 mcb to BS 3871 45A type B circuit breaker to BS EN 60898* 50A type 1 mcb to BS 3871 50A type B circuit breaker to BS EN 60898

### 4.2.1 General

- WARNING:** This appliance **MUST BE EARTHED**.
- The wiring must comply with the current I.E.E Requirements for Electrical Installations (BS 7671) and the requirements of the local electricity utilities.
- It is the responsibility of the competent electrical installer to use the details in this manual with the latest British Standards.
- The appliance has integral 9kW electric backup boiler and therefore the supply must be 230V~, 50Hz rated at 45A as discussed below in table 4.4.
- All electrical wiring to the appliance should be secured to prevent the wires/cables touching any hot surfaces inside and outside the appliance case.
- The appliance is supplied with 2m long, 10mm<sup>2</sup> (twin + E) flexible cable and it must be connected to a local (not more than 2m away from the appliance) 45A double pole isolator having a contact separation of at least 3mm in both poles as shown in figure 4.5.

### 4.2.2 Connecting Power Supply to the Appliance

- Ensure that the electricity supply is switched off.
- The appliance is supplied with 2m long 10mm<sup>2</sup> (twin + E) flex. Uncoil this and connect it to the local fixed isolator (figures 1.1.1.2 and 4.5).
- DO NOT SWITCH ON** the electricity supply to the appliance at this stage.

### 4.2.3 Room Thermostat (Standard Models)

The standard GulfStream models are supplied with factory fitted and wired two channel programmer for controlling the hot water and space heating on-off time periods. This appliance is only suitable for connecting 230V, 50Hz i.e. mains voltage room thermostats.

- Wire the room thermostat to the appliance terminals as shown in figure 4.6.

# INSTALLATION AND WIRING

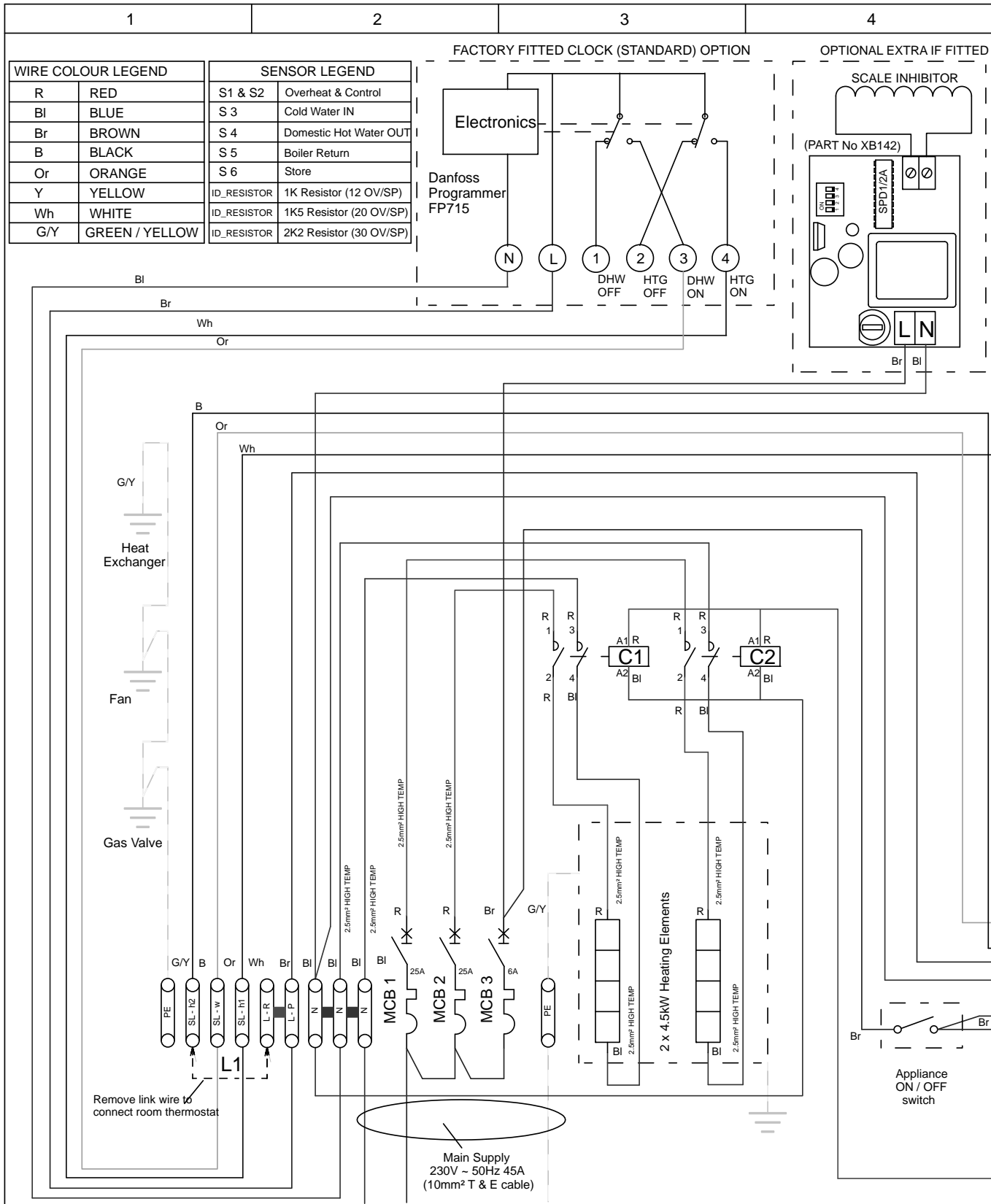

NOTE : Diverter Valve  
 Port A = Heating  
 Port B = Hot Water  
 Blue/Brown (2 & 3) energised = Port A closed  
 Blue/Black (2 & 6) energised = Port B closed

DRN. G. Bott  
 DATE 09-11-06  
 CHK S. M

DATE: NOVEMBER 2006

ISSUE No : 3

APPROVED

# INSTALLATION AND WIRING

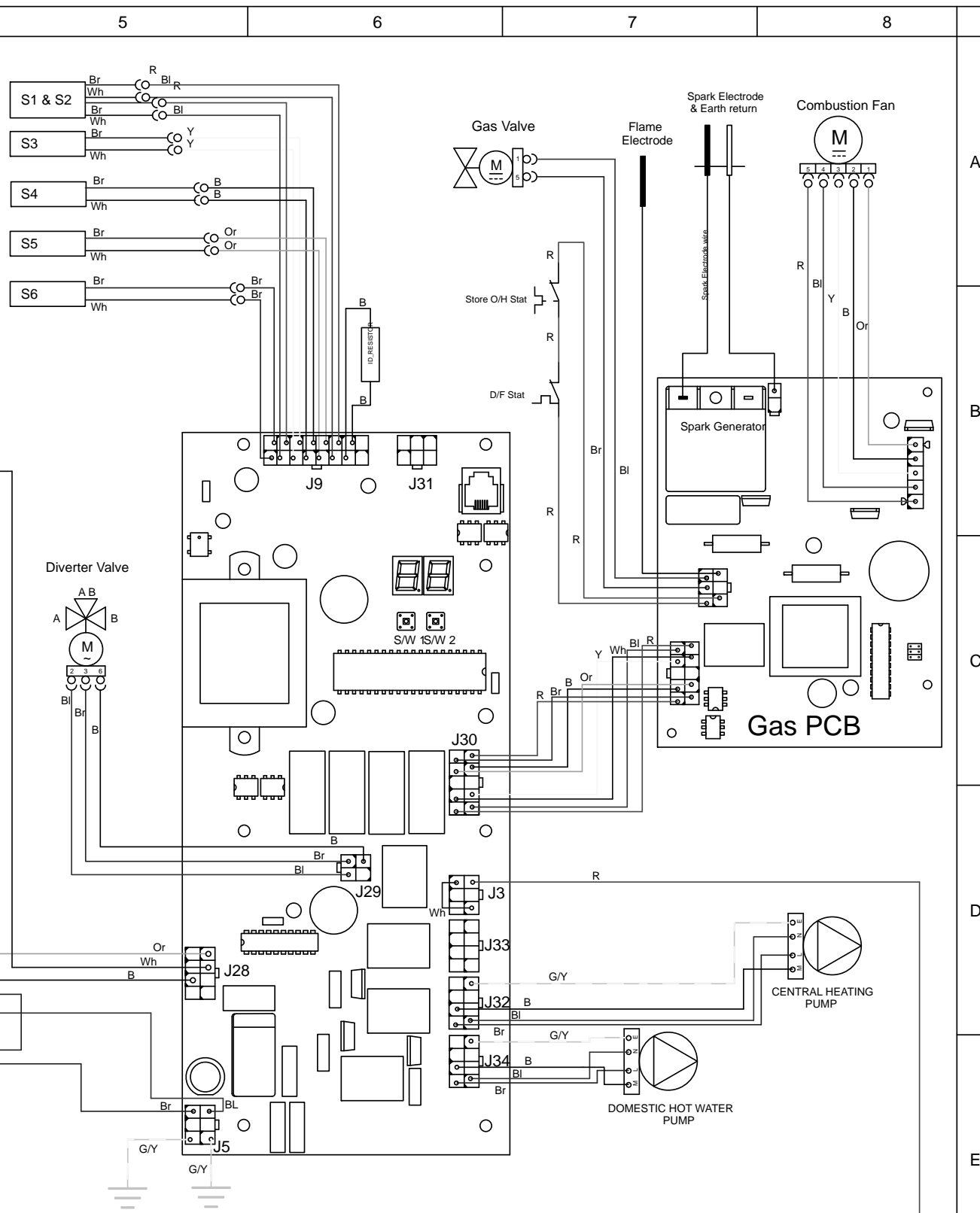

\* All wire sizes 0.5mm<sup>2</sup> unless otherwise stated

D. McGachie	APP'D. S. Gataora	DATE 09-11-06	TITLE 'A' CLASS GULFSTREAM APPLIANCE ELECTRICAL SCHEMATIC DRAWING	JOB NAME 'A' CLASS GULFSTREAM APPLIANCE
GLEDHILL WATER STORAGE LTD. SYCAMORE TRADING ESTATE SQUIRES GATE LANE BLACKPOOL LANCASHIRE FY4 3RL			DO NOT SCALE FROM THIS DRAWING. COPYRIGHT OF THIS DRAWING IS RESERVED. IT IS NOT TO BE REPRODUCED COPIED OR DISCLOSED TO A THIRD PARTY EITHER WHOLLY OR IN PART WITHOUT OUR WRITTEN CONSENT. © GLEDHILL WATER STORAGE LTD.	DRG. SIZE A3 DRG. NAME 'A' Class Gulfstream Issue 3.ai

# INSTALLATION AND WIRING

Appliance terminal	Room thermostat terminal
L-R	'L' supply in
N	'N' supply in
E	'E' supply in
SL-h2	Switched live 'SL' out

## 4.2.4 2-Channel programmable room thermostat

Any make of 230V ac, two channel programmable room thermostat for controlling the hot water and space heating on-off time periods can be connected to the NO clock option models of the GulfStream.

- Remove links L1, L2 and L3 from terminals labelled 'L-P'; 'L-R'; 'SL-W'; 'SL-h1' and 'SL-h2' (see figure 4.4B).
- Wire the programmable room thermostat to the appliance terminals as shown in figure 4.7.

- A link between terminals 'SL-h2' and 'SL-h1' must be inserted.

Appliance terminal	Programmable room thermostat terminal
L-P	'L' supply in
N	'N' supply in
E	'E' supply in
SL-h2	Space heating switched live 'SL-HTG' out
SL-W	Hot water switched live 'SL-HW' out

## 4.2.5 Remote programmer and room thermostat

A two channel remote programmer and a room thermostat for controlling the system can be connected to the NO clock option models of the GulfStream. This appliance is only suitable for connecting 230V, 50Hz i.e. mains voltage external user controls.

- Remove links L1, L2 and L3 from terminals labelled 'L-P'; 'L-R'; 'SL-W'; 'SL-h1' and 'SL-h2' (see figure 4.4B).
- Wire a remote programmer and a room thermostat to the appliance terminals as shown in figure 4.8

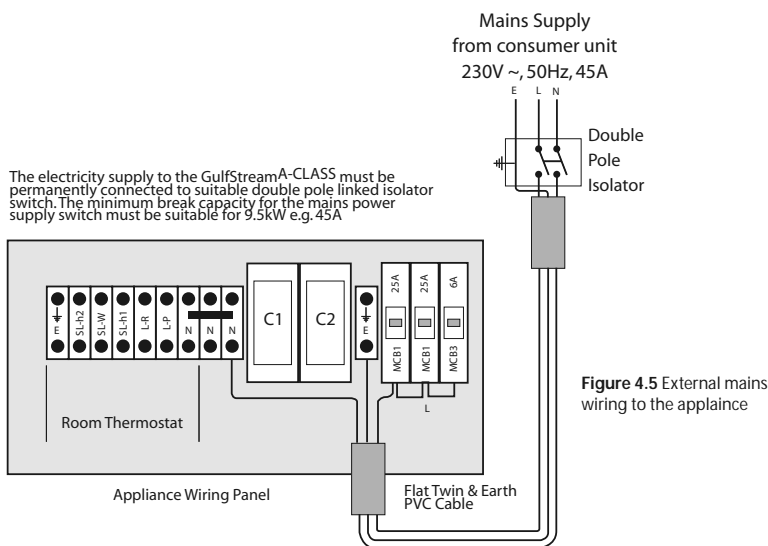

Figure 4.5 External mains wiring to the appliance

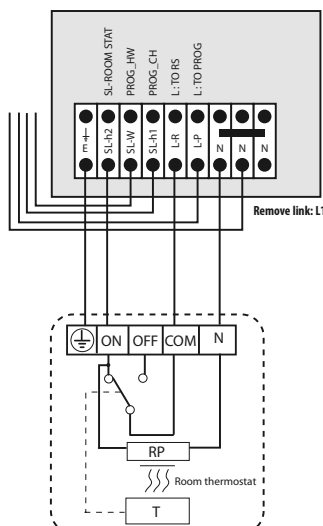

Figure 4.6 Room thermostat wiring diagram for standard GulfStream models with factory fitted 2 channel programmer (Standard)

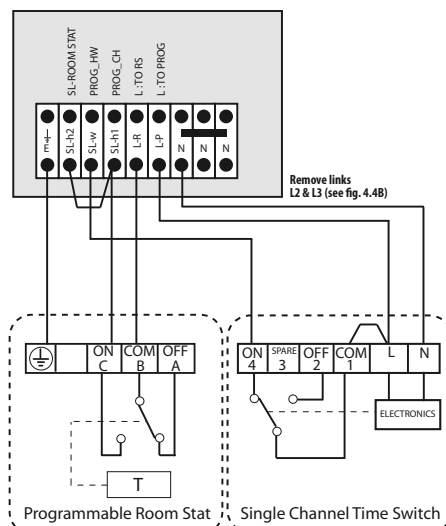

Figure 4.7 Danfoss programmable room thermostat (TP5000) wiring diagram for space heating & single channel time clock for the hot water, for GulfStream with NO factory fitted clock option

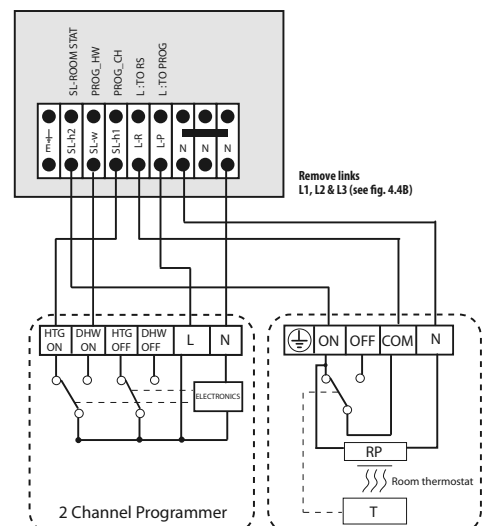

Figure 4.8 Remote 2-Channel Programmer and standard room thermostat wiring diagram for GulfStream with NO factory fitted clock option

Appliance terminal	Programmer & room thermostat terminal
L-P	Programmer 'L' supply in
N	Programmer 'N' supply in
E	Programmer 'E' supply in
SL-h1	HTG switched live 'SL' out from programmer
SL-W	HW switched live 'SL' out from programmer
L-R	Room thermostat 'L' supply in
N	Room thermostat 'N' supply in
E	Room thermostat 'E' supply in
SL-h2	Switched live 'SL' out from room thermostat

#### 4.2.6 Frost Thermostat

- (a) The appliance has built in frost protection which will prevent the appliance temperature dropping below about 5°C.
- (b) However if a frost thermostat is required and fitted to protect other parts of the system, then it should be wired in to the appliance control panel across terminals L-P and SL-h1 and SL-h2. For further details please contact our technical department.

## 5. COMMISSIONING

- (a) It is essential that the system functions properly for optimum performance. To achieve this, the heating and the hot water system should be commissioned in accordance with good practice and generally with the requirements of BS 6798, BS 5449 and BS 7593. Full details of the requirements are given in PAS 33:1999 under section 10 Commissioning.
  - (b) An automatic air vent is built into the top of the appliance and the red cap should be open during commissioning to ensure all air has been removed from the system. After a suitable commissioning period the cap should be tightened for long term safety.
- IMPORTANT:** To enable the appliance/system to fill easily please follow the instructions on the appliance and remove the 3 port valve actuator.
- (c) **WARNING:** Do not attempt to start this appliance unless the appliance and the heating system have been filled with water and thoroughly vented.

### 5.1 INITIAL SYSTEM FILLING

- (a) Open the cold water stop cock on the inlet to the appliance and allow water to flow through the appliance to the domestic hot water taps. Ensure all air is vented and there are no leaks.
- (b) Open the central heating flow and return isolating valves.

#### 5.1.1 Open Vented System

- (a) Fill the open vented system in the normal way through the feed and expansion (F & E) cistern.
- (b) When the system is full check if the water level in the F & E cistern is correct and adjust the ballvalve if necessary.
- (c) Check the functioning of the overflow/warning pipe and regulate the service valve so that in a fault condition, the warning/overflow pipe can carry the maximum water supply into the F&E cistern.

#### 5.1.2 Sealed System

- (a) The sealed system model is fitted with an automatic filling device (CA-Valve) and the system is filled directly from the mains supply to a nominal operating pressure of 1.0 bar (when cold).
- (b) Before filling check the air pressure in the expansion vessel is 1.0 bar and if necessary adjust it to 1.0bar or the recommended system design pressure.
- (c) Open any isolating valves and fill and vent the system in the normal way.
- (d) If draining down is necessary, first release any internal pressure by opening the pressure relief valve, then after ensuring that all system and boiler vents are open, open the drain valve.

### 5.2 PRELIMINARY ELECTRICAL AND GAS SYSTEM CHECKS

- (a) These electrical checks must be carried out prior to attempting to start the appliance. They are; Earth Continuity, Short circuit, Resistance to Earth and Polarity.

The gas installation including the gas meter must be inspected and tested for gas soundness and purged in accordance with the recommendations of the current issue of BS 6891 before attempting to start the appliance.

# COMMISSIONING

## 5.3 CLEANSING AND WATER TREATMENT

### 5.3.1 Water Treatment

**WARNING:** We only recommend 'Fernox Superfloc' cleaning agent and Fernox MB1 protector for this appliance. The correct use of this cleaning agent and the correct strength of this inhibitor will ensure that the system water is clean and the pH level is between 7 and 8, which is essential to maintain the efficient operation and long life of the aluminium heat exchanger. Failure to do this correctly will result in premature corrosion of the heat exchanger/blocking of the waterways and neither of these situations will be covered by the appliance warranty.

The correct quantities of cleaning and treatment agents should be determined from the manufacturer's instructions and the 100 litre water content of the store must be included. General guidelines for quantities of cleansing and treatment agents are shown in table 5.1.

- (a) Ensure that all cleansing/treatment of the heating system is carried out fully in accordance with the instructions provided by Fernox.
- (b) The water system must be thoroughly flushed out, initially with cold water and ensuring that all valves are fully open.
- (c) Refill the system to normal working pressure. Examine for water leaks. Rectify if necessary.
- (d) Add Fernox Superfloc Cleansing Agent to ensure that all flux residues and installation debris are removed from the system.
- (e) Heat the system to full operating temperature, check for water leaks and rectify if necessary. Flush the system again until it is clean.
- (f) Refill the system and add Fernox MB1 Protector to the system ensuring that the system is fully vented.

**Table 5.1 Quantities of cleansing and treatment agents (litres)**

Heating circuit design heat loss (kW)	Fernox Superfloc	Fernox MB1
6	5.0	1.2 - 2.4
12	5.9	1.5 - 3.0
18	6.9	1.7 - 2.4
24	7.8	2.0 - 4.0
30	8.8	2.2 - 4.4

### 5.3.2 Power Flushing/Cleaning of the Heating System

- (a) When carrying out the work, always comply fully with the manufacturers' instructions for the power flushing equipment.
- (b) We would always recommend that the GulfStream<sup>A-CLASS</sup> appliance is isolated from the heating system being cleaned.
- (c) If in any doubt, please consult our Technical Help line.

## 5.4 FLUE SYSTEM

- (a) The flue system should have been designed and installed in accordance with the requirements under 'Flue System Design, section 3.4' in this manual.
- (b) Check that sealing of terminal(s) and pipes is sound and acceptable.
- (c) Check that horizontal lengths of flue pipe fall back to the boiler and that there are no low points where the condensate could collect.



# COMMISSIONING

## 5.5 CONTROL PANEL, DISPLAY & DIAGNOSTICS

The appliance controls fitted to the GulfStream<sup>A-CLASS</sup> have been designed to be fully automatic and to provide functional and diagnostic information to the installer/commissioning engineer.

### 5.5.1 Appliance model identification

In order to comply with the latest gas safety regulations, this appliance is fitted with a model identification resistance. The controller reads this ID tag and compares it with the appliance code set on the controller. The two must match for the appliance to function. If there is a mismatch, the appliance will shut down safely and flag the error message '33' on the display.

The appliance ID data is shown in table 5.2 and the procedure for setting the appliance code if a controller is replaced is described in section 5.5.3 (h)

**(Warning:** Under no circumstances should the appliance ID resistor be changed or tampered with).

Table 5.2 Appliance ID data		
Model	Appliance code	Appliance ID resistor
12 OV/SP	10	1K
20 OV/SP	20	1K5
30 OV/SP	30	2K2

If the boiler develops a fault (indicated by flashing red indicator light i.e. Led 3) then proceed as follows:

1. If the red light **is** flashing
  - (a) Press button 1 to reset and return to gas boiler operation
  - (b) If the red light switches off - the fault has been cleared
  - (c) If the red light flashes again after 2 minutes - the fault has not been cleared. Go to 2 below.
2. If the red light **is still** flashing
  - (a) Press button 2
  - (b) If the red light switches on permanent - the 'switch' electric backup has been selected. Pressing button 2 again will deselect the 'switch'.
  - (c) If red light continues flashing - 'switch' electric backup cannot be used.

Table 5.3: Description of front panel controls		
LED	Status	Function indication
Led 1 (green)	ON	Control circuit power supply is on
	OFF	Control circuit power supply switched off or faulty
Led 2 (yellow)	OFF	Gas boiler in standby mode i.e. burner is off
	FLASHING	Gas boiler is in ignition phase
	ON	Flame has been sensed and the gas boiler (i.e. burner) is on
Led 3 (Red)	OFF	Gas boiler is in standby mode i.e. healthy
	FLASHING	Boiler requires resetting e.g. lockout fault has occurred. (See below)
	ON	Electric backup boiler has been selected (See below)
Push Button		
	1	Used to reset gas boiler and clear faults
	2	Used to select 'Switch' electric backup

### 5.5.2 Front Panel Controls

The operation of the appliance is indicated on the front panel (figure 5.1) by green, yellow and red indicator lights (LEDs). The push buttons 1 and 2 are used to reset the boiler and to switch the backup electric boiler on /off in the event of a gas boiler failure. The functions of the front panel controls are described below in table 5.3.

If the electric backup boiler has been selected, (indicated by permanently ON Red Led\_3). The user can switch the electric backup boiler ON and OFF by pressing Button\_2. To permanently switch the electric boiler off and select the gas boiler, switch OFF by pressing Button\_2 and then press Button\_1.

### 5.5.3 Main PCB Functions & Diagnostics

The controller functions and faults are indicated on the 2 digit display mounted on the main PCB and the display functions are selected by the push buttons B1 and B2 (figure 5.2). The flow chart of the display mode is shown in figure 5.3. The display functions are described below: -

- (a) **Normal mode:** In this mode the display (figure 5.2) is used to indicate the status of different input demands and output functions. The first left hand digit is used to indicate demands sensed by the controller and the second right hand digit indicates the output functions of the controller.

This mode is selected by button B1 and the display description is presented in table 5.4.

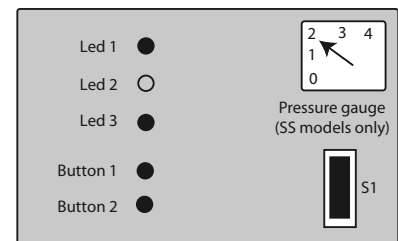

Figure 5.1: Front panel display

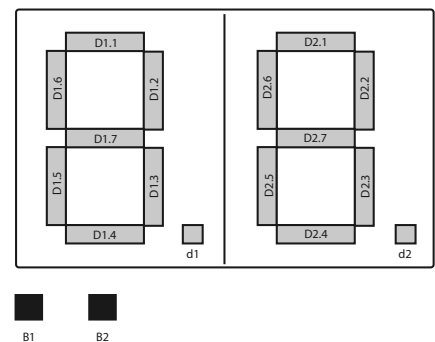

Figure 5.2 Display and push buttons on main PCB

# COMMISSIONING

- (b) **Temperature mode:** In this mode the current temperature read by the selected sensor is displayed. The button B1 is used to select this mode and the button B2 is used to select the appropriate sensor.

The temperature is indicated by alternatively flashing the sensor number and its temperature reading or the error code. For example if sensor S1 is selected and the temperature reading is 90°C, then the display will flash to indicate 'S1' and '90'. If the temperature sensor is faulty, then the display will flash to indicate 'S1' and 'EN' when EN is the error code. The error code will be as follows:

- E1 – Open circuit
- E2 – Short circuit
- E3 – Temperature >99°C

The sensors used in this appliance are described in table 5.5.

- (c) **Set point mode:** In this mode the set points used in the control of the appliance are displayed. The button B1 is used to select the mode and the button B2 is used to select the set-point. The set-point readings are displayed by alternatively flashing the set-point number and its value. The set points which can be displayed are shown in table 5.6.
- (d) **Fan speed mode:** In this mode fan speeds used in control of the boiler are displayed. The button B1 is used to select this mode and the button B2 is used to select the appropriate fan speed reading.

The fan speed reading, in rpm, is displayed by alternatively flashing the fan speed number 'FN' and the corresponding fan speed reading divided by 100. For example preset ignition speed of 3222 rpm will be displayed by alternatively flashing 'F3' and '32'. The fan speed readings available for this appliance are shown in table 5.7. (**Note:** The fan speed i.e. appliance input can only be read but not changed.)

Segment	Indication
D1.1	ON - Boiler in ignition phase OFF - Boiler in standby phase
D1.2	ON - Store thermostat calling OFF - Store thermostat satisfied
D1.3	ON - Room thermostat calling OFF - Room thermostat satisfied
D1.4	ON - Electric backup ON OFF - Electric backup not ON
D1.5	ON - Programmer calling for HTG OFF - Programmer not calling for HTG
D1.6	ON - Programmer calling for HW OFF - Programmer not calling for HW
D1.7	ON - Boiler firing OFF - Boiler in standby mode
D2.1	ON - PHE pump running OFF - PHE pump in standby mode
D2.4	ON - Boiler pump running OFF - Boiler pump in standby mode
D2.7	ON - Diverter valve in HTG position OFF - Diverter valve in HW position
d1	Flashing - Controller working OK
d2	Flashing - Boiler lockout mode

Display	Sensor
S1	Boiler overheat/control 1
S2	Boiler overheat 2
S3	PHE cold water inlet
S4	DHW outlet
S5	Boiler return
S6	Store
Note: When backup electric boiler is selected, sensors S1 - S6 are used to control the 'switch'	
S7	Appliance I.D.

Display	Set point
S1	Store thermostat S6 on set-point
S2	Store thermostat S6 off set-point
S3	DHW inlet sensor S3 set-point
S4	DHW outlet sensor S4 set-point
S5	Boiler on S1 set-point
S6	Boiler off S1 set-point

Display	Fan speed
F1	Minimum
F2	Maximum
F3	Ignition
F4	Current

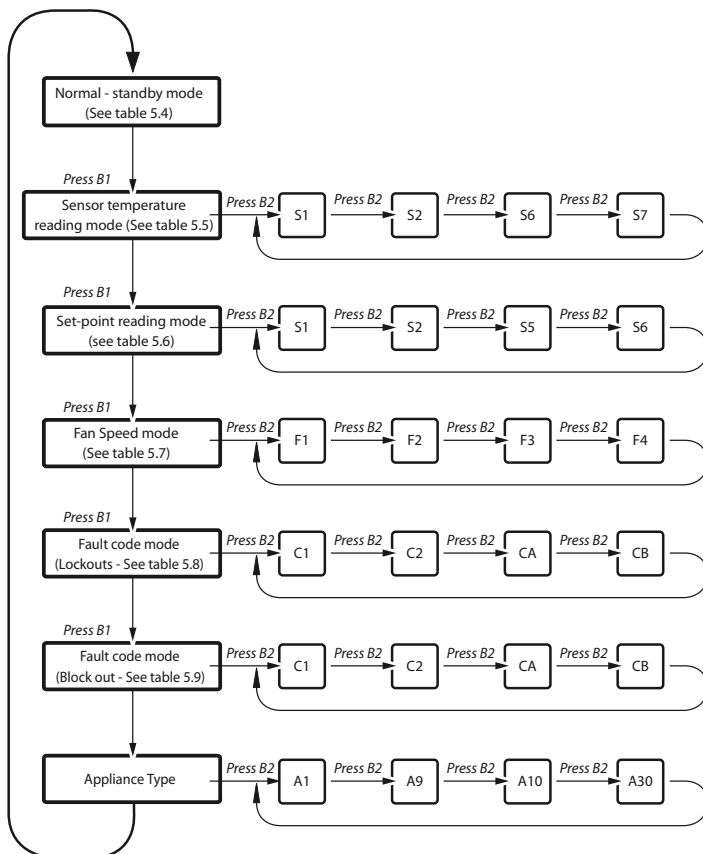

Figure 5.3 Display and push buttons on main PCB

- (e) **Lock out fault Code mode:** In this mode the lockout fault codes are displayed. The button B1 is used to select this mode and the button B2 is used to cycle between the stored faults. The fault code reading is displayed by alternatively flashing the fault number and the internal error number.

There are 16 fault codes stored in order of occurrence. The fault code 'C0' is the current or last fault code and the fault code 'CF' is the previous fault.

When no fault is stored at the displayed fault number, an 'FF' is displayed. It is also possible that 'EE' is displayed for an internal error number. This means that the controller is busy reading the memory. The lockout error codes are listed in table 5.7.

The locking errors can be cleared by pressing the reset button B1.

- (f) **Block out fault code mode:** In this mode the block out fault codes can be displayed. The button B1 is used to select this mode and the button B2 is used to cycle between the stored faults. Fault code reading is displayed by alternatively flashing the fault number and the internal error number.

There are 16 fault codes stored in order of occurrence. The fault code 'c0' is the current or last fault code and the fault code 'cF' is the previous fault.

When no fault is stored at the displayed fault number, an 'FF' is displayed. It is also possible that 'EE' is displayed for an internal error number. This means that the controller is busy reading the memory. The block out error codes are listed in table 5.8.

Blocking errors are displayed as a non blinking number, with or without a dot. The error will be reset when the fault is cleared. To reset some internal errors switch power off, wait 10 seconds and switch power on again.

- (g) **Non Blocking or Locking Errors**

These are displayed as a blinking number with or without a dot between normal operation state and error code. These errors do not require resetting. To remove the error the defective part or component must be repaired.

These errors do not stop the controller from functioning, although the service may be impaired in some circumstances.

### 5.5.3(h) Appliance type mode

The appliance type/code selection menu (A10, A20, A30) is hidden. It is only possible to get to the appliance selection using the reset button (B1) on the main board. When going from the show 'locking error' to show 'blocking error' menu do not release the button but hold it for 10 seconds. The display will change from 'c' to 'A'. At this stage the appliance type can be selected.

All models have a unique ID tag as part of the appliance wiring harness (see section 5.1). The controller reads this tag and compares it with the model selected on the controller and the procedure for setting the appliance code in the controller is described below.

- The appliance selection menu (A0 ... A9, A10 ... A30) on the controller is hidden. It is only possible to get to the appliance selection using the reset button (Left hand, B1) on the main board.
- When going from the show 'locking error' to show 'blocking error' menu (see figure 5.3), do not release the button but hold it for 10 seconds. The display will change from 'c' to 'A'. At this stage the push button (B1) can be released.
- The appliance type can now be selected by using right hand push button, B2, e.g. A03.

- Press the reset button, B1, to accept the setting.

- If the selected appliance code does not match with the ID Resistor fitted to the appliance, then, an error '33' will be displayed.

### 5.5.3(i) Error codes and handling

Errors are divided into two categories with two groups each. The categories are;

- Main errors for the main control including the burner and CH errors
- DHW errors for the DHW state machine

The first category is divided into two groups. One group of locking errors and one group of blocking errors.

A main locking error can only be reset by pressing the reset button. If the appliance power supply is interrupted the appliance will return to the main locking state it was in before the interruption occurred. Locking errors are used to indicate severe errors that can cause a safety critical situation.

Less critical errors are indicated as blocking errors. These errors can sometimes be resolved without user intervention. Once the cause for the blocking error disappears the appliance resumes with normal operation.

If no error (locking or blocking) is detected the internal error number is set to 255 and the digital point of the left display digit flashes. If any error is detected the fault number is set to the corresponding internal error number, the digital point of the right display digit flashes and if necessary the burner is stopped. If more than one error conditions occurs at the same time the error with the highest priority overrules the error with a lower priority. The lower the internal error number, the higher the priority of an error.

## 5.6 INITIAL LIGHTING

- (a) Check that the electricity supply is ISOLATED and basic electricity supply checks listed in section 5.2 have been carried out.
- (b) Ensure that the boiler and system are full of water and the system is thoroughly vented. For sealed systems ensure that the system is charged to 1.0 bar nominal pressure.
- (c) Turn on the gas supply and open the gas service cock to purge the gas line in accordance with the current issue of BS 6891. After purging procedure check for gas leaks and rectify any faults.

# COMMISSIONING

Table 5.7 Locking error name	Internal error number	Remarks	Eh backup enabled
E2PROM_READ_ERROR	0	Control error	No
SAFETY_RELAY_ERROR	1	Control error	No
E2PROM_ERROR	2	Control error	No
WRONG_EEPROM_SIGNATURE	3	Control error	No
ROM_ERROR	4	Control error	No
RAM_ERROR	5	Not used (control is reset)	-
20MS_ERROR	6	Not used (control is reset)	-
41MS_ERROR	7	Not used (control is reset)	-
STACK_ERROR	8	Not used (control is reset)	-
GV_RELAY_ERROR	9	Control error	No
OVERHEAT_ERROR	10	Sensor error, overheat detected	No
OVERHEAT_DIFFER_ERROR	11	Sensor error, overheat sensors differ	No
T_MAX_LOCK_ERROR	12	Burner error (overheat)	Yes
FLAME_OUT_TOO_LATE_ERROR	13	Burner error	Yes
FLAME_ERROR_1	14	Burner error	Yes
IGNIT_ERROR	15	Burner error	Yes
TOO_MANY_FLAME_FAILURES	16	Burner error	Yes
15MS_ERROR	17	Not used (control is reset)	-
FLAG_BYTE_INTEGRITY_ERROR	18	Control error	No
AD_HI_CPL_ERROR	19	Control error	No
AD_LO_CPL_ERROR	20	Control error	No
REGISTER_ERROR	21	Control error	No
FAN_ERROR	22	Not used	Yes
BOILER_RELAY_ERROR	23	Not used	Yes
EH_RELAY_ERROR	24	Not used	No

- (d) Ensure that both space heating and hot water are switched off at the 2 channel programmer.
- (e) Switch on the mains supply. The controller will initialise and green LED on the front panel will illuminate.
- (f) Switch on hot water demand at the 2 channel programmer. The bars D1.6 and D1.2 (figure 5.2) will come on and the boiler will go through the ignition sequence and then start heating the store. During the ignition sequence, the yellow LED on the front panel will flash and when the burner is on, the yellow LED will be permanently on.
- (g) If the burner fails to ignite the controller will automatically restart the ignition sequence and will make 5 attempts to ignite the burner. If a lock out condition occurs, it will be indicated by a flashing red LED on the front panel. The lockout can be cleared by pressing button B1 on the front panel.
- (h) Measure and record the inlet gas pressure in the 'Benchmark' logbook.

Table 5.8 Blocking error name	Internal error number	Remarks	Eh backup enabled
REFHI_TOO_LO_ERROR	25	Control error	No
REFHI_TOO_HI_ERROR	26	Control error	No
REFLO_TOO_LO_ERROR	27	Control error	No
REFLO_TOO_HI_ERROR	28	Control error	No
WD_COMMUNICATION_ERROR	29	Control error	No
PHASE_DETECTION_ERROR	30	Control error	No
50HZ_ERROR	31	Control error	No
RESET_BUTTON_ERROR	32	Control error	No
APPLIANCE_SELECTION_ERROR	33	Control error	No
OVERHEAT_1_ERROR	34	Sensor error	No
OVERHEAT_2_ERROR	35	Sensor error	No
GP_LOST_ERROR	36	Burner error / Control error	Yes
T_OVERHEAT_1_OPEN	36	Sensor error	No
T_TANK_BOTTOM_OPEN	38	Sensor error	Yes
SPARE_BLOCK_ERROR_39	39	Not used	-
T_FLUE_OPEN	40	Sensor error	Yes
SPARE_BLOCK_ERROR_41	41	Not used	-
T_TANK_MIDDLE_OPEN	42	Sensor error	Yes
SPARE_BLOCK_ERROR_43	43	Sensor error	Yes
T_OVERHEAT_2_OPEN	44	Sensor error	No
T_OVERHEAT_1_SHORTED	45	Sensor error	No
T_TANK_BOTTOM_SHORTED	46	Sensor error	Yes
SPARE_BLOCK_ERROR_47	47	Not used	-
T_FLUE_SHORTED	48	Sensor error	Yes
SPARE_BLOCK_ERROR_49	49	Not used	-
T_TANK_MIDDLE_SHORTED	50	Sensor error	Yes
SPARE_BLOCK_ERROR_51	51	Not used	Yes
T_OVERHEAT_2_SHORTED	52	Sensor error	No
FLAME-ERROR-2	53	Burner error	Yes

When the T\_TANK\_MIDDLE sensor is defective store heating is still possible. Because the demand for store depends on this sensor, in this case the T\_OVERHEAT sensor can be used instead of T\_TANK\_MIDDLE to determine if demand for store is active.

Table 5.9 DHW Warning error names	Internal DHW error number	Remarks	DHW handling enabled
DHW_T_DHW_OUT_OPEN	0	DHW error	Limited
DHW_T_DHW_IN_OPEN	1	DHW error	Limited
DHW_T_DHW_OUT_SHORTED	2	DHW error	Limited
DHW_T_DHW_IN_SHORTED	3	DHW error	Limited

There are no locking errors for DHW. If a DHW\_ERROR occurs both the error - and ok indicators will flash on the display to indicate a non fatal error.

Table 5.10 Tank Temperature Warning Table		
No.	Definition	Store Heating
0	T_Tank_Top/Middle_Open	limited
1	T_Tank_Bottom_Open	limited
2	T_Tank_Top/Middle_Shorted	limited
3	T_Tank_Bottom_Shorted	limited
4	EB_Failure	limited

# COMMISSIONING

## 5.7 CENTRAL HEATING SYSTEM

- Once the store is heated and this can take between 10 and 15 minutes, switch on heating on the 2 channel programmer/room thermostat. This will be indicated by bars D1.3 and D1.5 on the main PCB display.
- Please note that if the store temperature is less than about 65°C, the radiators will not heat.
- With flow to the central heating circuit, bleed every radiator and pipework high points until air or air/water mix has been removed.
- The GulfStream appliance is fitted with an automatic air valve. This should be open during the commissioning but the plastic cap should be closed once all the air has been released from the system to protect against any leaks. The valve should be opened in the normal way whilst any work is being carried out on the system and closed again on completion.
- Wait until the heating circuit has reached its normal temperature of approximately 80°C before balancing the system in the usual way to achieve a temperature drop between 10 and 12°C.
- Ensure that the system has been flushed and treated.
- For sealed systems record the cold and hot system pressures in the 'Benchmark' logbook.
- Set the programmable room thermostat as per manufacturer's instructions supplied with the appliance and ensure that the room thermostat instructions (along with the appliance) are left with the user.

## 5.8 DOMESTIC HOT WATER SYSTEM

- Open a hot water tap nearest to the appliance at approximately 6 litres/minute. After about 2 – 3 seconds, the plate heat exchanger pump will start. This is indicated by on main PCB display by bar D2.1.

- Record the hot water outlet temperature in the 'Benchmark' logbook. Close this tap and open the hot bath tap at 18 litres/minute flow rate and record the flow rate and the hot water temperature in the 'Benchmark' logbook.
- Close the hot water tap(s) and after few seconds, the plate heat exchanger pump will stop running and bar D2.1 on the main PCB will switch off.

## 5.9 HAND OVER TO USER

- Explain the system and the appliance controls to the user
- Explain how to operate the heating and hot water controls to the user. This should include setting heating and hot water 'on' and 'off' times on the 2 channel programmer, the room temperature on the programmable room thermostat and the use of thermostatic radiator valves.
- Advise that the appliance should be serviced regularly and only by a CORGI registered service person.
- Explain how to start the appliance if the red neon indicates ignition lockout.
- Explain how to select the emergency backup electric boiler if the red neon indicates boiler failure.
- Handover appliance and room thermostat user instructions and put the completed "Benchmark" logbook and the appliance instruction manual in the pocket on the inside of the appliance front panel.
- DON'T place any clothing or other combustible materials against or on top of

The unique **switch** Emergency back-up system

This unit has an emergency electric back-up system, for heating and hot water in the heating season or hot water only in the summer.

If the boiler develops a fault proceed as follows:

- If the red light is flashing
  - Press button 1 to reset and return to gas boiler operation.
  - If red light switches off - the fault has been cleared.
  - If red light flashes again after 2 minutes - the fault has not been cleared. Go to 2 below.
- If the red light is still flashing
  - Press button 2.
  - If red light switches on permanent - the 'Switch' electric backup has been selected.
  - If red light continues flashing - 'Switch' electric backup cannot be used.

\* Call service engineer if the boiler has not reset to gas boiler operation after 2 attempts.

In all Gledhill products there is no release of ozone depleting substances or harmful emissions.

**ON:** Control circuit power on

**OFF:** Gas boiler burner off  
**FLASHING:** Gas boiler in ignition phase  
**ON:** Gas boiler burner on

**OFF:** Gas boiler in standby mode  
**FLASHING:** Gas boiler fault (see opposite)  
**ON:** 'Switch' electric backup boiler selected (see opposite)

**BUTTON 1:** Used to reset Gas Boiler and clear faults

**BUTTON 2:** Used to select 'Switch' electric backup

234

↑

10

OFF

ON

Appliance

# ROUTINE ANNUAL SERVICING

## 6. ROUTINE ANNUAL SERVICING

To ensure safe and efficient operation of the appliance, it is necessary to carry out routine servicing at regular intervals. The frequency of servicing will depend on the particular installation conditions and use to which the appliance is put. In general, once a year should be adequate.

It is the law that any service work must be carried out by a competent person such as British Gas or other CORGI registered personnel.

- a) **IMPORTANT** Before commencing a service or changing a component, ISOLATE the mains electric supply TURN OFF the gas supply at the main service cock and when necessary turn off and drain the heating/domestic water system.
- b) **To gain access to all components:** First remove the front panel by unscrewing the two retaining screws towards the top LH and RH sides. Lift the panel slightly and swing it forward from the top. Lift the panel to disengage it at the bottom edge. Remove the top panel by lifting front edge from the brass studs provided and slide/lift forward; the top front support bar can be removed by unscrewing the brass studs at the top and the two self-tapping screws on the front.

A combustion sampling point has been provided on the flue outlet at the top of the boiler. Remove the hex. screw to access (See Figures 1.1 and 1.2).



Figure 6.1 Venturi and Fan Assembly

### 6.1. BURNER, GAS VALVE AND VENTURI –FAN SUB-ASSEMBLY

Remove the sub assembly shown in figures 6.1 and 6.2 for inspection as follows:

- Disconnect HT – Sensor and Earth leads from the burner.
- Slacken flexible air hose clip around Venturi inlet and remove hose.
- Pull the sensor line off the nipple on the gas valve.
- Remove the plug in electrical connector from the gas valve.
- Disconnect the gas line (union connection) from the gas valve.
- Remove the (3) hexagon nuts fixing the assembly to the top of the boiler using a 11mm AF spanner.
- Lift the assembly clear of the mounting studs – ease the end of the gas line out of its fitting.
- If the assembly is clean (apart from acceptable dust) it will not be necessary normally to disassemble it further, unless a careful inspection shows signs of deterioration.
- Should it become necessary to remove or replace components, follow the procedure under 'Component Exchange'. Carefully clean the assembly i.e. remove any dirt with soft brush and check for signs of wear or deterioration of supply leads, burner, igniter and sensor assemblies. The burner must show no sign of oxidation or cracking.
- Check and if necessary reset the ignition spark gap to  $4.5 \pm 0.5$ mm and the flame sensor position (figure 6.2).

### 6.2. CLEANING THE HEAT EXCHANGER

- Reach down and carefully lift out the central core (ceramic fibre) of the boiler heat exchanger.
- Examine and replace if there are indications of it beginning to break up or there is evidence of ceramic particles dropping to the bottom of the heat exchanger.
- Remove the condense trap from the boiler.
- Remove the (3) hexagon nuts fixing the bottom boiler casting using a 11mm AF spanner.
- Lower the bottom casting clear off the mounting studs – ease the flue outlet from its socket.
- Clean the heat exchanger if necessary with a brush and remove any debris.
- After completing this part of the service procedure refit the ceramic core to the heat exchanger and reassemble the appliance in reverse order.
- CARRY OUT A GAS SOUNDNESS TEST
- Examine the remainder of the appliance checking for signs of deterioration or wear in other components – replace as necessary. Look for signs of water leaks – repair/replace as necessary.

- Open the cap on the automatic air vent fitted on the appliance to release any small amounts of air which may have collected since the last service and close again on completion of the commissioning procedure.
- Refer to the 'Commissioning' Procedure. Operate the appliance – preferably commencing with a dry run (GAS OFF). Check all safety controls and boiler operation under normal conditions. Adjust as necessary.

### 6.3. CLEANING THE CONDENSATE TRAP

This procedure must be carried out after the appliance has been switched off and made safe. Remove the trap by undoing nuts 'A' and 'B'. Clean the trap by removing plug 'C' taking precautions regarding water in the trap (figure 6.3). Refit in reverse order and check for leaks. It is normal to expect a build up of deposits in the trap.

### 6.4. POWERFLUSHING/CLEANING OF HEATING SYSTEM

If it is proposed to 'powerflush' the heating system we would recommend that the GulfStream appliance is isolated from the heating system being cleaned. Failure to do this could seriously damage the appliance.

When carrying out the work always comply fully with the manufacturers instructions for the 'power flushing' equipment being used. If in any doubt please consult our Technical Helpline.

# ROUTINE ANNUAL SERVICING

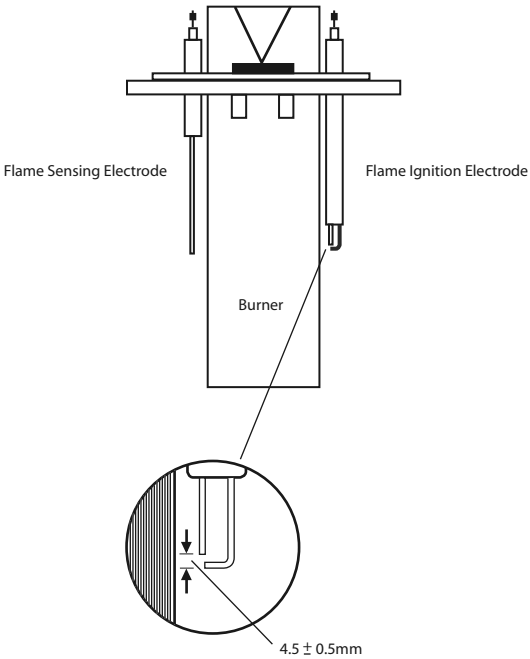

Figure 6.2 Spark & Flame sensing electrodes

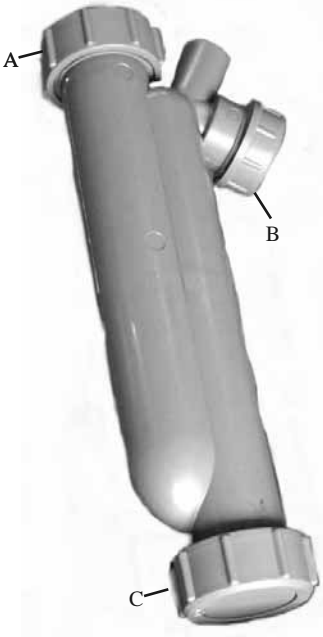

Figure 6.3 Condensate trap

# SERVICING AND CHANGING COMPONENTS

## 7 SERVICING AND CHANGING COMPONENTS

- (a) **IMPORTANT:** Before commencing a service or changing a component, ISOLATE the mains electrical supply at the main isolator and TURN OFF the gas supply at the service cock and when necessary turn off and drain the heating/domestic water systems.
- (b) To assist with a component identification and associated wiring refer to Figures 1.1, 1.2, 1.3, and 1.4.
- (c) Before changing any part please check the part/stock code no/voltage ratings are the same as the part being replaced.

Free of charge replacements for any faulty components are available from Gledhill during the in-warranty period (normally 12 months). After this, spares should be obtained direct from Gledhill using the 'Speed Spares' service or through any of the larger plumbers merchants/specialist heating spares suppliers.

Help and advice is also available from the Technical Helpline on 08449 310000. However, all components are readily accessible and can be changed quickly and easily by the installer using common plumbing practice.

- (d) It is recommended that all subsequent service calls are recorded on the Service Interval record which can be found on page 40. Details from the Benchmark checklist and Service Interval record will be required when requesting warranty work. Failure to provide these details or the lack of a current service will delay a warranty visit and may incur a charge for the visit.

### 7.1 GAS VALVE AND VENTURI

- (a) The burner, gas valve, venturi and fan components form part of a sub-assembly, which must be removed before one of them can be exchanged. Remove this assembly by following the procedure detailed under 'Routine Annual Servicing'. Remove these components as a common assembly – then split and replace as necessary.
- (b) Disconnect the valve from the Venturi by removing the three torque head screws. DO NOT MISPLACE THE SYNTHETIC RUBBER SEALING WASHER – BETWEEN THE COMPONENTS.
- (c) The Venuri is easily removed by unscrewing the 2 slotted pan head screws to reveal the cork gasket. If the gas valve is to be replaced remove the male ½" gas connection from the old valve. Fit it to the replacement valve using an approved jointing compound.
- (d) BEFORE re-assembling the gas valve/Venturi, check the soundness of the cork gasket and rubber washer. Replace if deteriorated or damaged. Check and reset gas rate and burner pressure page (see table 2.2)
- (e) **NOTE:** Exchange of either gas valve or venturi will necessitate re-commissioning of the appliance. This requires special equipment and should only be undertaken if this equipment is available. The commissioning procedure is supplied with the parts.

### 7.2 COMBUSTION AIR FAN

- (a) Remove the main sub-assembly as stated above (Section 7.1 (a)) and remove the gas valve/Venturi assembly.
- (b) Disconnect the fan from the burner/adaptor casing by removing the (4) hexagon nuts behind the mounting flange using a 7mm AF spanner.
- (c) If necessary exchange the fan and re-assemble in reverse order.
- (d) Replace the fan sealing gasket if the existing shows any signs of deterioration.
- (e) Check boiler/controls operation.

### 7.3 BURNER – REMOVAL

- (a) Remove the main sub-assembly as stated above (Section 7.1 (a)).
- (b) Disconnect the burner from the burner/adaptor casing by removing the (4) hexagon nuts on top of the casting using an 8mm AF spanner/socket.

- (c) If necessary exchange the burner and reassemble in reverse order.
- (d) REPLACE the fan sealing gasket if the existing shows any signs of deterioration.
- (e) Check boiler/controls operation.

### 7.4 IGNITION AND FLAME SENSOR ELECTRODES

- (a) Both components are removed in the same manner.
- (b) Disconnect the appropriate lead.
- (c) Ignition Electrodes – HT and EARTH
- (d) Sensor – SENSOR LEAD
- (e) Remove the (2) cross head screws retaining the component and carefully lift it up out of the combustion chamber.
- (f) If necessary exchange the component.
- (g) ALWAYS fit a new ceramic sealing gasket.
- (h) Re-assemble in reverse order.
- (i) Check boiler/controls operation.

### 7.5 FLAME VIEWING WINDOW

- (a) Remove the (2) cross head screws retaining the frame.
- (b) Lift off the frame and site glass.
- (c) Clean/exchange the site glass as necessary
- (d) ALWAYS fit new ceramic sealing gaskets.
- (e) Re-assemble in reverse order.

### 7.6 DRY FIRING THERMOSTAT

- (a) Pull off the leads on top of the thermostat.
- (b) Unscrew the body (counter clockwise).
- (c) If necessary exchange and re-assemble in reverse order.
- (d) Check boiler/controls operation.

### 7.7 STORE OVERHEAT THERMOSTAT ('-SS' MODEL ONLY)

- (a) Remove (pull off) the leads from the back.
- (b) Remove the central fixing nut.
- (c) Remove the split pin at the thermostat phial pocket and pull out the phial.
- (d) Remove the thermostat.
- (e) Replace as necessary and re-assemble in reverse order. Finally depress thermostat reset button.
- (f) Check boiler/controls operation.

### 7.8 BOILER OVERHEAT THERMOSTAT – REMOVAL

See 7.20.

### 7.9 PRESSURE GAUGE ('-SS' MODEL ONLY)

- (a) Isolate the appliance from the heating system.
- (b) Isolate the cold supply to the primary system/appliance at the quarter turn valve on the inlet to the CA valve assembly.
- (c) Open the safety valve to release internal boiler pressure.
- (d) Drain down the boiler to below the level of the safety valve.



# SERVICING AND CHANGING COMPONENTS

- (e) Unscrew (counter clockwise) the capillary at the valve using a 14mm AF spanner.
- (f) Remove the knurled nut at the back of the gauge and pull the capillary out through the panel.
- (g) If necessary exchange and re-assemble in reverse order.
- (h) Refill the boiler ensuring all air is removed.
- (i) UNDERTAKE WATER SOUNDNESS TEST.
- (j) Check boiler/controls operation.

## 7.10 SAFETY I.E. PRESSURE RELIEF VALVE ('-SS' MODEL ONLY)

- (a) Isolate the appliance from the heating system.
- (b) Isolate the cold supply to the primary system/appliance at the quarter turn valve on the inlet to the CA valve assembly.
- (c) Open the safety valve to release any internal pressure. Drain down the boiler to below the level of the safety valve.
- (d) Operate the valve once more to remove residual water and disconnect the capillary of the pressure gauge from the valve using a 14mm AF spanner.
- (e) Disconnect the valve inlet and discharge pipe nuts using a 22mm AF spanner and remove the valve.
- (f) If necessary exchange the valve and re-assemble in reverse order.
- (g) Refill the boiler ensuring all air is removed.
- (h) UNDERTAKE WATER SOUNDNESS TEST.
- (i) When full allow the appliance to reach full temperature and check the valve is water tight.
- (j) Check boiler/controls operation.

## 7.11 EXPANSION VESSEL ('-SS' MODEL ONLY)

- (a) Isolate the appliance from the heating system.
- (b) Isolate the cold supply to the primary system/appliance at the quarter turn valve on the inlet to the CA valve assembly.
- (c) Open the safety valve to release any internal pressure.
- (d) Drain down the boiler to below the level of the safety valve.
- (e) Remove all residual water possible through safety valve discharge.
- (f) Disconnect the flexible pipe from the top of the expansion vessel using a 30mm spanner and pull the vessel upwards and to the left out of its recess. DO NOT MISPLACE THE SEALING WASHER.
- (g) Exchange the vessel if required and re-assemble in reverse order.
- (h) Check the air pressure is set at 1.0 bar at the Schrader valve provided on the top of the expansion vessel.
- (i) Refill the boiler ensuring all air is removed.
- (j) UNDERTAKE WATER SOUNDNESS TEST.
- (k) Check boiler/controls operation.

## 7.12 FASCIA MOUNTED BURNER CONTROL PCB

- (a) Undo the 2 slotted screws and drop down the hinged fascia panel.
- (b) Remove terminal/block plugs (3) and spade connector from the pcb.
- (c) Undo the 4 x 5mm plastic securing nuts and remove the PCB.
- (d) Disconnect the earth lead from the pcb.
- (e) Replace if necessary and re-assemble in reverse order ensuring the terminal blocks are pushed fully home.
- (f) Replace any severed cable ties.
- (g) Check and ensure the jumper positions are correct (See instructions supplied with the part)
- (h) Check boiler/controls operation.

## 7.13 MAIN 'ACB' PCB

- (a) Remove the terminal/block plugs (8) at the edge of the PCB.
- (b) Gently ease the PCB off its supports (8).
- (c) Replace if necessary and re-assemble in reverse order.
- (d) Ensure 'A' parameter for appliance type is correctly set (see table 5.2)
- (e) Check boiler/controls operation.

## 7.14 COLD WATER SENSOR

- (a) Isolate and drain down as necessary the hot/cold water system.
- (b) Remove the electrical connector from the thermistor.
- (c) Unscrew using a 15mm AF spanner and remove the thermistor.
- (d) Replace if necessary and reassemble in reverse order making a watertight seal using PTFE tape.
- (e) Refill cold water system.
- (f) UNDERTAKE WATER SOUNDNESS TEST.
- (g) Check boiler/controls operation.

## 7.15 DHW SENSOR

- (a) Isolate and drain down as necessary the hot/cold water system.
- (b) Remove the electrical connector from the thermistor.
- (c) Unscrew using a 15mm AF spanner and remove the thermistor.
- (d) Replace if necessary and reassemble in reverse order making a watertight seal using PTFE tape.
- (e) Refill cold water system.
- (f) UNDERTAKE WATER SOUNDNESS TEST.
- (g) Check boiler/controls operation.

## 7.16 STORE SENSOR

- (a) Remove the thermistor from its pocket and disconnect from the plug.
- (b) Replace if necessary and re-assemble in reverse order ensuring the thermistor is pushed fully into its pocket.
- (c) Check boiler/controls operation.

## 7.17 BOILER RETURN SENSOR

See 7.20.

## 7.18 PLATE HEAT EXCHANGER (PHE)

- (a) Isolate the boiler from the heating system.
- (b) Isolate the incoming stop valve and drain down the hot/cold water system.
- (c) With the SP model open the safety valve to release any internal pressure.
- (d) Drain down the boiler to below the level of the PHE.
- (e) Disconnect the union connectors (4) at the corners of the plate heat exchanger using a 29mm AF spanner and remove the plate.  
**Note:** It is easier to remove the 2 front nuts and adjacent pipework to get access to the back 2 nuts.
- (f) When draining the plate heat exchanger take precautions against standing water in the pipework and the heat exchanger.
- (g) Replace if necessary and re-assemble in reverse order.
- (h) NOTE: Replace the sealing washers at each connection during re-assembly.
- (i) Undertake water soundness test.
- (j) Check boiler/controls operation.

# SERVICING AND CHANGING COMPONENTS

## 7.19 ELECTRIC BOILER (SWITCH)

- (a) Isolate the boiler from the heating system.
- (b) Isolate the cold supply to the appliance at the servicing valve to the F & E cistern of the OV model and at the quarter turn valve on the inlet to the CA valve if the SP model.
- (c) With the SP model open the safety valve to release any pressure.
- (d) Drain down the boiler to below the level of the electric boiler.
- (e) Disconnect mains supply cables (4) to the heater element from the bottom of the 2 relays.
- (f) Remove the split pin and pull out the control/OH thermistor from its pocket.
- (g) Disconnect the union connectors (2) at the inlet and outlet of the electric boiler using a 37mm AF spanner and remove it.
- (h) Unscrew the cable from the earth tag.
- (i) When removing the electric boiler take precautions against any standing water in the pipework.
- (j) Replace if necessary and reassemble in reverse order.
- (k) UNDERTAKE WATER SOUNDNESS TEST.
- (l) Replace any cable ties.
- (m) Check boiler/controls operation

## 7.20 BOILER OVERHEAT THERMOSTAT / ELECTRIC BOILER CONTROL THERMOSTAT

- (a) Isolate and drain down as necessary the primary water system.
- (b) Remove the 4 way electrical connector from the thermistor
- (c) Unscrew using a 15mm AF spanner and remove the thermistor
- (d) Replace as necessary and reassemble in reverse order making a watertight seal using PTFE tape.
- (e) Refill primary system
- (f) Undertake water soundness test
- (g) Check boiler/ controls operation

## 7.21 DHW PUMP

- (a) Close the isolation valves on the inlet and outlet of the pump.
- (b) Remove the protective cover from the pump terminal block and disconnect the supply cable from the quick release terminals.
- (c) Unscrew the 4 securing bolts using a 4mm allen key and remove the pump head.
- (d) NOTE: SOME RESIDUAL WATER FROM THE PUMP HOUSING IS UNAVOIDABLE.**
- (e) Replace if necessary and re-assemble in reverse order.
- (f) UNDERTAKE WATER SOUNDNESS TESTS
- (g) Check boiler/controls operation.
- (h) The pump is a Grundfos UPR 4 wire type and any replacement must be the same model, obtained direct from Gledhill.

## 7.22 BOILER/CH PUMP

- (a) Close the isolation valves on the inlet and outlet of the pump.
- (b) Remove the protective cover from the pump terminal block and disconnect the supply cable from the quick release terminals.
- (c) Unscrew the 4 securing bolts using a 4mm allen key and remove the pump head.
- (d) NOTE: SOME RESIDUAL WATER FROM THE PUMP HOUSING IS UNAVOIDABLE.**
- (e) Replace if necessary and re-assemble in reverse order.
- (f) UNDERTAKE WATER SOUNDNESS TEST.
- (g) Check boiler/controls operation.
- (h) The pump is a Grundfos UPR 4 wire type and any replacement must be the same model, obtained direct from Gledhill.

## 7.23 AUTOMATIC AIR VENT

- (a) Gently unscrew the cylindrical top part of the valve (above the hexagonal nut) by hand checking no water is released. If no water is released replace the top part only of the valve.

- (b) If water is released drop the system pressure using the safety relief valve (SS model only) and then drain down the boiler to below the level of the AAV. Unscrew the hexagonal bottom part of the valve incorporating a non return valve using a 22mm AF spanner.
- (c) Replace the total valve using PTFE tape on the threads to make watertight.
- (d) UNDERTAKE WATER SOUNDNESS TEST.
- (e) Check boiler/controls operation.

## 7.24 BYPASS VALVE

- (a) Isolate the boiler from the heating system.
- (b) With the SP model drop the system pressure using the safety relief valve and then drain down the boiler to below the level of the bypass valve.
- (c) Release the two jubilee clips and remove the flexible air inlet hose.
- (d) Unscrew the union connection on the heating flow to the right of the bypass valve using a 40mm AF spanner.
- (e) Unscrew the bottom inlet nut of the bypass valve.
- (f) Remove the bypass valve and pipework assembly and unscrew the outlet nut of the bypass valve.
- (g) Replace the bypass valve and reassemble in reverse order using new washers on the heating flow and expansion vessel connections.
- (h) On the SP model unscrew the nut on the flexible connector to the expansion vessel using a 30mm AF spanner taking precautions against any standing water in the hose.

## 7.25 CA VALVE – (SP MODEL ONLY)

- (a) Isolate the 2 quarter turn valves either side of the CA/pressure reducing valve assembly.
- (b) Unscrew the 2 union nuts either side of the CA valve using a 37mm AF spanner push off the silver bezel on the connection to the tundish and remove the valve.
- (c) When removing the valve take precautions against any standing water in the valve.
- (d) Replace the valve and reassemble in reverse order making sure the new valve is inserted in the correct direction (arrow down) and the 2 washers are replaced.
- (e) UNDERTAKE WATER SOUNDNESS TEST.
- (f) Check boiler/controls operation.

## 7.26 PRESSURE REDUCING VALVE ('-SS' MODEL ONLY)

- (a) Isolate the quarter turn valve on the inlet (top) of the CA valve assembly.
- (b) Isolate the heating system and drain down the boiler.
- (c) Disconnect the compression nut on the outlet of the quarter turn valve (bottom) below the pressure reducing valve using a 24mm AF spanner.

# SERVICING AND CHANGING COMPONENTS

- (d) Disconnect the union nut on the inlet (above) the pressure reducing valve using a 37mm AF spanner and remove the valve/assembly.
- (e) Replace the valve in the assembly and reassemble in the boiler in reverse order making sure to replace the washer in the union connector.
- (f) UNDERTAKE WATER SOUNDNESS TEST.
- (g) Check boiler/controls operation.

## 7.28 3-WAY HYDRONIC VALVE ACTUATOR (Figure 6.4)

- (a) Depress the tab and unplug the 3 way connector from the left hand side of the actuator.
- (b) To remove the actuator press in (forward) the latch mechanism to the centre rear of the actuator. At the same time press the actuator towards the body of the valve and turn the actuator counter clockwise (to the left) by 45 degrees (1/8 turn). Pull the actuator away from the body.
- (c) Replace the actuator and reassemble in reverse order.

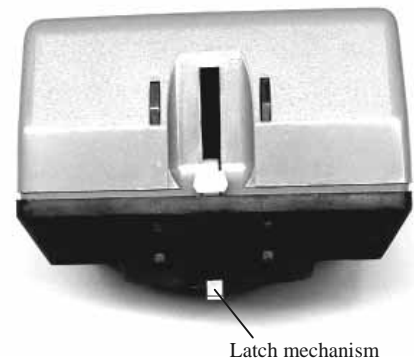

Figure 6.4 Diverter Valve Actuator

## 7.29 3-WAY DIVERTER VALVE BODY

- (a) Any faults with the valve itself are overcome by replacing the removable internal cartridge.
- (b) Other than due to a faulty casting/leaking joint there should be no need to replace the valve body itself.
- (c) Instructions for replacing the cartridge and the necessary removal tool are all provided with the replacement cartridge.
- (d) Before replacing the cartridge isolate the appliance from the heating system.
- (e) With the SP model open the safety valve to release any internal pressure and isolate the cold supply at the quarter turn valve on the inlet to the CA valve.
- (f) With the OV model shut off the servicing valve on the cold inlet to the ball-valve in the F & E cistern in both cases then drain down the boiler to below the level of the 3-way valve.
- (g) Remove the actuator following the instructions above and then remove the cartridge using the special tool provided.
- (h) Replace if necessary the cartridge and reassemble in reverse order.
- (i) UNDERTAKE WATER SOUNDNESS CHECK.
- (j) Check boiler/controls operation.

## 7.30 ELECTRICAL CONTACTOR (Figure 6.5)

- (a) Release the wires from the terminals on both sides of the 25 amp contactor.
- (b) Insert a 4mm slotted head screwdriver into the release tab below the contactor and push down.
- (c) Pull the contactor upwards and lift off the mounting rail.
- (d) Replace and reassemble in reverse order ensuring the tab clips back into position and all wiring connections are tight.
- (e) Check boiler/controls operation.

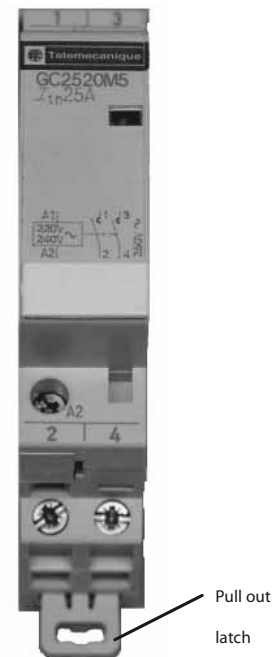
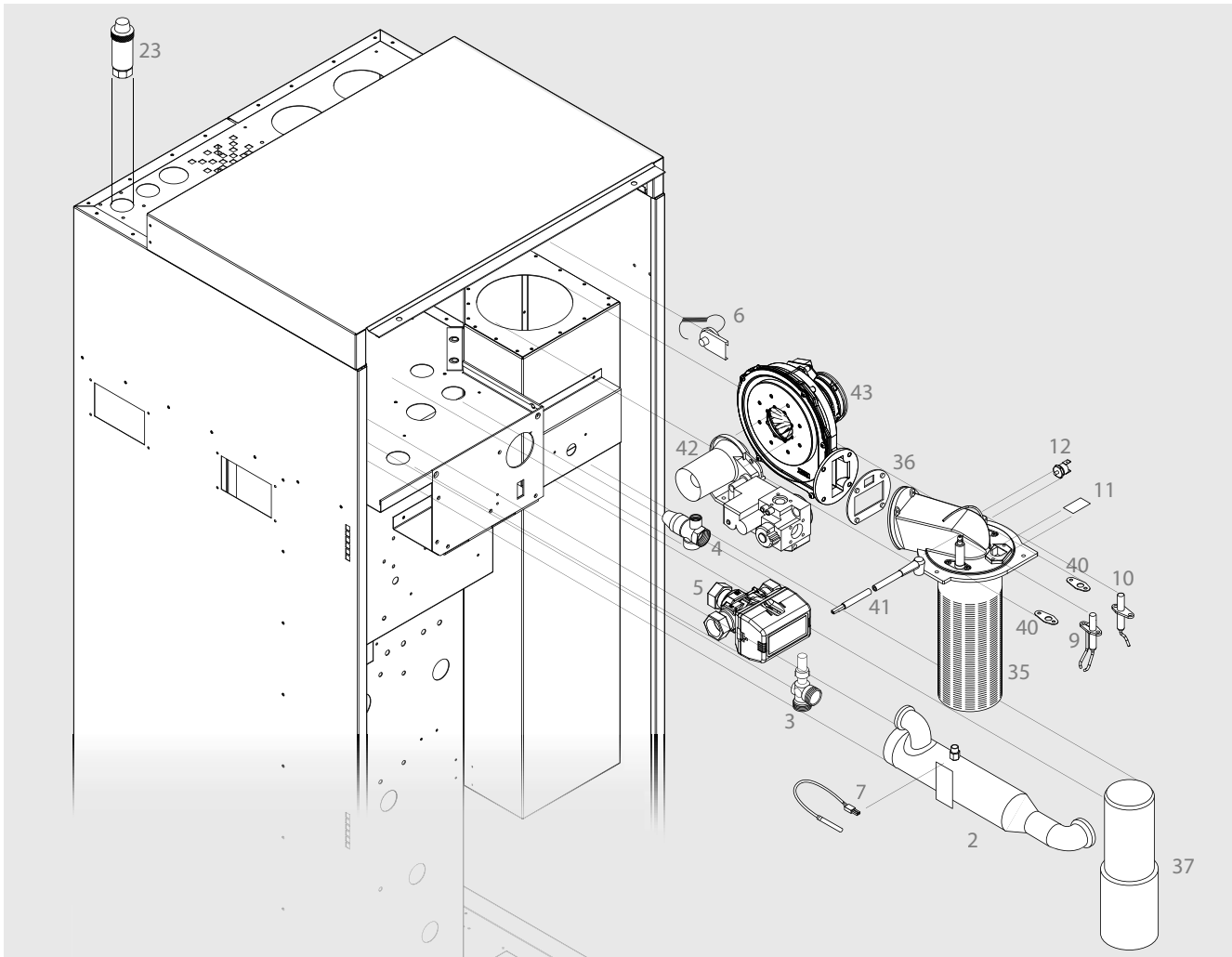

Figure 6.5 25A Contactor

## 7.31 M.C.B. – REMOVAL

- (a) Release the wires from the terminals on both sides of the MCB and remove the bus bar from the inlet (bottom).
- (b) Insert a 4mm slotted head screwdriver into the release tab below the MCB and push down.
- (c) Pull the MCB upwards and lift off from the mounting rail.
- (d) Replace and reassemble in reverse order ensuring the tab clips back into position and all wiring connections are tight.
- (e) Check boiler/controls operation.

# PARTS LIST



Item No.	Description	No. off	Stock Code
2	Switch element	1	GT061
3	By-pass Valve	1	XG185
4	3 Bar Expansion Relief Valve	1	GT195
5	Honeywell Hydronic Valve Cartridge and Hydronic Actuator	1	GT047
6	Store Overheat Thermostat	1	GT064
7	Electric Boiler Control / Overheat Thermostat	1	GT199
9	Spark Electrode	1	GT307
10	Flame Sensing Electrode	1	GT309
11	Sight Glass	1	GT248
12	Boiler Dry Firing Safety Thermostat	1	GT171
23	Auto Air Vent	1	GT015
35	Burner assembly	1	GT163
36	Gasket fan	1	GT165
37	Displacement ceramic case	1	GT166
40	Gasket electrode	1	GT310
41	Ignition lead	1	GT451
42	Gas valve and Venturi Assembly	1	GT185/GT338
43	Fan blower	1	GT335

# PARTS LIST

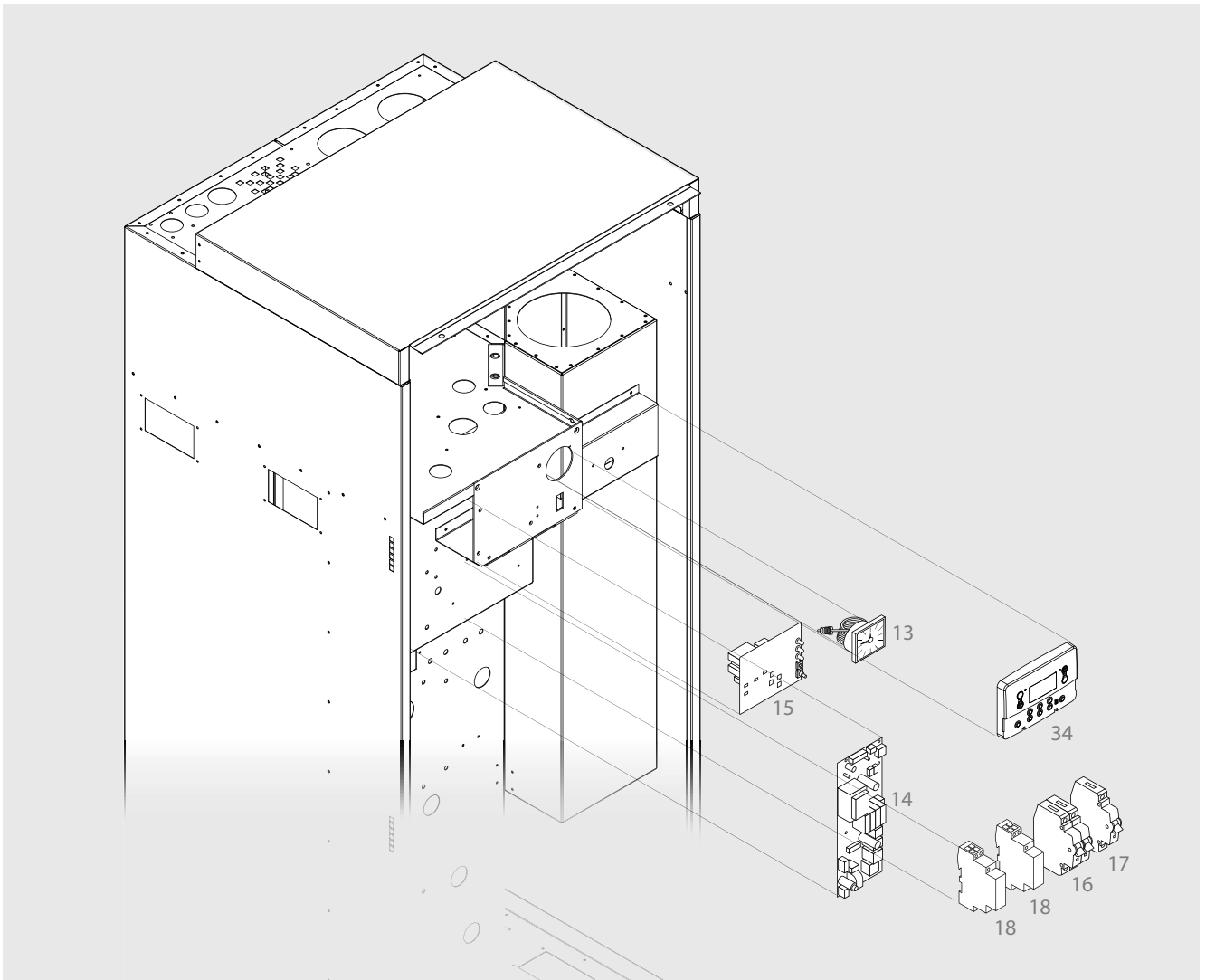

Item No.	Description	No. off	Stock Code
13	Primary System Pressure Gauge	1	GT179
14	Main PCB	1	GT490
15	Gas plugin PCB	1	GT102
16	MCB - Single Pole 25 Amp	2	XB452
17	MCB - Single Pole 6 Amp	1	XB449
18	Contactor 2 Pole N/O 25 Amp	2	XB014
34	Danfoss FP715 Programmer	1	GT394

# PARTS LIST

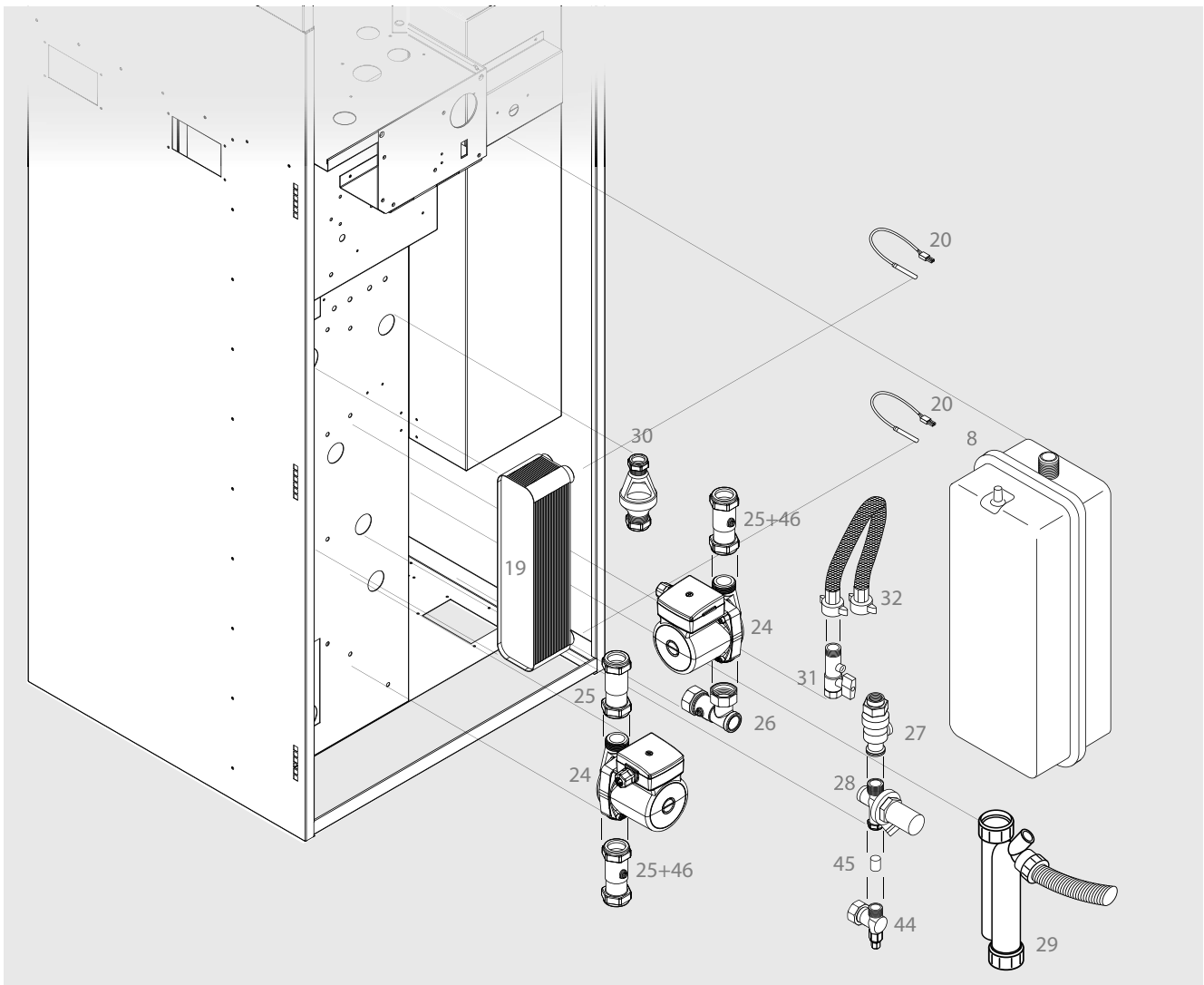

Item No.	Description	No. off	Stock Code
8	12 Litre Expansion Vessel	1	GT162
19	Plate Heat Exchanger	1	GT017
20	PHE Sensor (S3/S4)	1	GT198
24	Grundfos 15/50 Pump with 1" connections	2	GT089
25	1" x 22mm Straight Pump Valve	3	GT133
26	1" x 22mm Angle Pump Valve	1	GT135
27	CA Backflow Prevention Valve	1	XB390
28	Pressure Reducing Valve	1	XB391
29	Condense Trap	1	GT059
30	22 x 15mm Straight Tundish	1	XG173
31	15mm Double Check Valve	1	XG004
32	½ inch hose	1	XG005
44	15mm x 1/2" Angled Isolation Valve	1	XB398
45	Check Valve	1	GT391
46	Isolation Valve	2	GT134

## WATER SAVINGS

WATER RELATED COSTS CAN BE REDUCED BY GOOD PLUMBING PRACTICE.

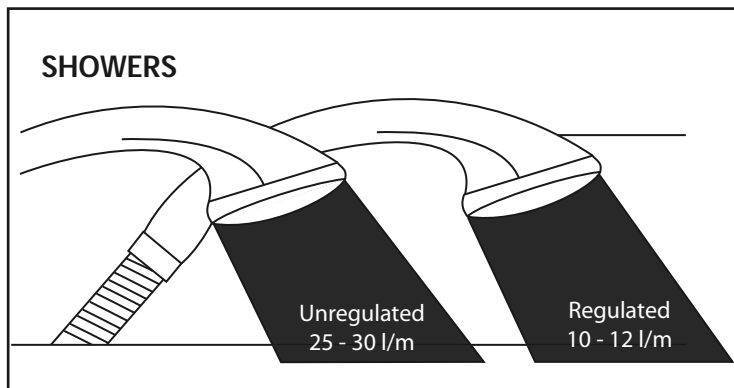
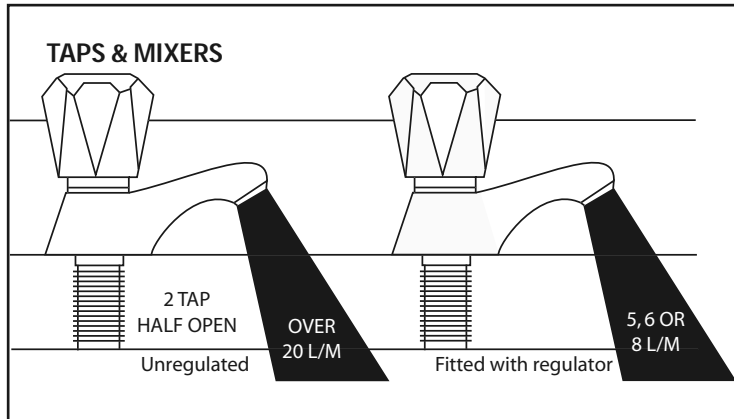

Vast quantities of water are needlessly run off to waste due to Taps, Mixers and Showers discharging flow rates far in excess of the rates required for them to perform their duties. The contrasting flow rates shown on this leaflet clearly illustrate the savings that can be made whilst still providing a good performance. British made Aquaflow Regulators provide constant flow rates by automatically compensating for supply pressure changes between 1 bar & 10 bars. To facilitate installation into the wide range of plumbing equipment which is encountered in the U.K, Four Fixing Options are available:-

## OPTIONS FOR SHOWERS

1. MXF "DW" Range - For fitting behind Fixed Shower Heads or onto Flexible Hoses for Handshowers (preferably onto the inlet end when lightweight hoses are used).
2. Compression Fitting Range. "In Line" regulators as in Option 4 for Taps & Mixers.

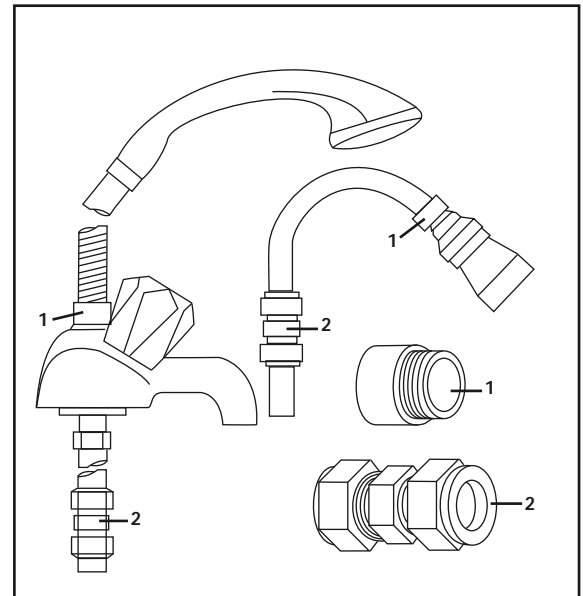

## 4 FIXING OPTIONS FOR TAPS & MIXERS

1. MK Range - Combined Regulators & Aerator for screwing onto Taps & Mixers with internal or external threads on their noses. Anti Vandal models also available.
2. MR05-T Range - Internal Regulators. Push-fit into Tap or Mixer seats. Produced in three sizes - 12.5mm (BS1010), 12mm & 10mm, Flangeless models also available for Taps with Low Lift washers.
3. MXF Standard Range - Screw on tail models for Taps & Mixers. Fix onto the tails before fitting the tap connectors. Available in 3/8", 1/2", 3/4" and 1" BSP.
4. Compression Fitting Range - "In Line" regulators housed in 15mm & 22mm CXC Couplers & Isolating Valves. "UK WFBS listed by the Water Research Centre. Isolation valves available for slotted screwdriver operation or with coloured plastic handles. Now available also in plastic bodied push-fit couplers & valves.

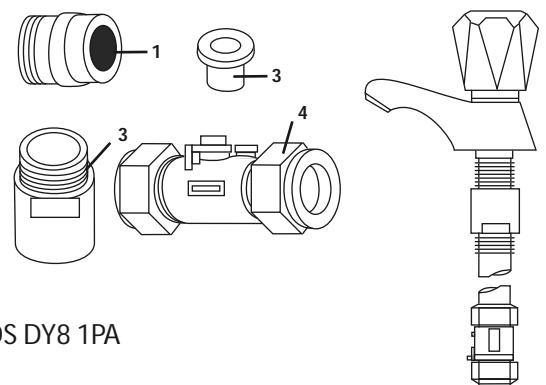

INFORMATION BY COURTESY OF  
**AQUAFLOW REGULATORS LTD**

HAYWOOD HOUSE, 40 NEW ROAD, STOURBRIDGE, WEST MIDLANDS DY8 1PA  
TELEPHONE (01384) 442611 FAX: (01384) 442612

### 2 Inhibitor (Corrosion & scale protection of primary heating circuit)

On filling the heating system and before the boiler is fired up, it is important to ensure the system water is treated with a suitable corrosion inhibitor, in accordance with the boiler manufacturer's instructions.

Since the concentration of inhibitor present in a system can become diluted, for a number of different reasons, the system should be checked annually and re-treated as required, or after every full or partial drain-down. A water treatment manufacturer's test kit may be used to check the correct concentration of inhibitor in the system.

Where recommended by a boiler manufacturer, a 'physical corrosion protection device' may be fitted in the primary pipework in accordance with the boiler manufacturer's instructions.

The Benchmark log book should be completed indicating the date and details of any of the above products added and a permanent label should be fixed to the system in a prominent location.





### 3 Scale protection (Domestic hot water service)

Where a combi boiler and/or a hot water storage vessel is installed in areas where the mains water can exceed 200ppm Total Hardness (as defined by BS 7593: 1993 Table 2) a scale reduction device should be installed, in accordance with the boiler manufacturer's instructions. The levels of water hardness may be measured using a water hardness test kit.

#### BUILDING REGULATIONS

Completion of the BENCHMARK log book requires that the 'competent person' undertaking the installation and commissioning provide information relating to Cleaning, Inhibitor and Scale Protection. This will demonstrate that the work complies with the requirements of the appropriate Building Regulations.

This Guidance Note is produced on behalf of its members by the Central Heating Information Council. For a full list of members visit [www.centralheating.co.uk](http://www.centralheating.co.uk) and for further advice on water treatment contact the following members:

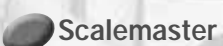
Heating & Hotwater Information Council, 36 Holly Walk, Leamington Spa,  
Warwickshire CV32 4LY Tel: 0845 600 2200 Fax: 01926 423284  
[www.centralheating.co.uk](http://www.centralheating.co.uk)



## MANUAL HANDLING OF APPLIANCE PRODUCTS

### Description

Manual handling means any transporting or supporting of a load (including lifting, putting down, pushing, pulling, carrying or moving) by hand or bodily force.

### Scope

This assessment will cover the largest Appliances, namely ElectroMats, GulfStream, BoilerMats, SyntexMats, PulseCoil, Accolade and Stainless Lite manufactured by Gledhill.

The maximum weight of the largest product in each range is 50kg and the size is 595 x 595 x 2120 mm high.

### Main Hazards

Vision may not be clear due to the size of the products. Adopting an incorrect method of lifting may cause injury, attempting to lift these products will require help from others. (Team lifts)

### Control Measures

#### Manual lifting procedure

The lift, key factors in safe lifting are:

- a. Balance
- b. Position of back
- c. Positioning of the arms and body
- d. The hold
- e. Taking the lead for team lifts

a. **Balance** - Since balance depends essentially upon the position of the feet, they should be apart about hip breadth with one foot advanced giving full balance sideways and forward without tension. In taking up this position, lifting is done by bending at the knees instead of the hips and the muscles that are brought into use are those of the thigh and not the back.

b. **Position of back** - Straight - not necessary vertical. The spine must be kept rigid, this coupled with a bent knee position, allows the centre line of gravity of the body to be over the weight so reducing strain.

c. **Positioning of arms and body** - The further arms are away from the side, the greater the strain on the shoulder, chest and back. Keep elbows close to the body arms should be straight.

d. **The hold** - Before lifting ensure you have a good hold. Two handles are provided on Appliance products at the top rear side, these allow one or two persons to have a purposely-designed hold at the top of the appliance to ensure easy lifting at the top of the product. Each appliance is supplied with a pallet, which has been attached to the unit via the packaging. The pallet will also allow for one or two persons to get a good hold.

- e. **Taking the lead for team lifts**- As more than one person is required for these products ensure that one person is taking the lead. This may be you so ensure that each person that is helping is made aware of the weight and of the items listed within this assessment. Make sure you and any others helping know the route you intend to take that it is clear of any obstructions. Never jerk the load as this will add a little extra force and can cause severe strain to the arms, back and shoulders. If there are steps involved decide on where you will stop and take a rest period. Move smoothly and in unison taking care to look and listen to others helping with the lift. Where possible use a sack truck to move the product over long flat distances, only lift the products when necessary. If in doubt stop and get more help. The unit handles and packaging with the pallet have been designed to ensure that two-four people can assist when lifting up stairs or over longer distances.

#### Individual capability

Individual capability plays an important part in handling these products. Persons above average build and strength will find it easier and should be in good health. Persons below average build and strength may require more rest periods during the handling process.

Pregnant women should not carry out this operation.

Persons who are not in good health should seek medical advice prior to commencing any lifting or manual handling operation.

#### Residual risk

Following the guidelines given above will reduce any risk to injury.

All persons carrying out this operation must be fully trained and copies of the specific risk assessment made available for inspection and use in their training process.

Further guidance on Manual Handling can be obtained from the Health and Safety Executive. Manual Handling Operations Regulations 1992.



BENCHMARK No. | | | | | | | |

# GAS BOILER COMMISSIONING CHECKLIST

BOILER SERIAL No. \_\_\_\_\_ NOTIFICATION No. \_\_\_\_\_

**CONTROLS** To comply with the Building Regulations, each section must have a tick in one or other of the boxes

TIME & TEMPERATURE CONTROL TO HEATING	ROOM T/STAT & PROGRAMMER/TIMER <input type="checkbox"/>	PROGRAMMABLE ROOMSTAT <input type="checkbox"/>
TIME & TEMPERATURE CONTROL TO HOT WATER	CYLINDER T/STAT & PROGRAMMER/TIMER <input type="checkbox"/>	COMBI BOILER <input type="checkbox"/>
HEATING ZONE VALVES	FITTED <input type="checkbox"/>	NOT REQUIRED <input type="checkbox"/>
HOT WATER ZONE VALVES	FITTED <input type="checkbox"/>	NOT REQUIRED <input type="checkbox"/>
THERMOSTATIC RADIATOR VALVES	FITTED <input type="checkbox"/>	
AUTOMATIC BYPASS TO SYSTEM	FITTED <input type="checkbox"/>	NOT REQUIRED <input type="checkbox"/>

### FOR ALL BOILERS CONFIRM THE FOLLOWING

THE SYSTEM HAS BEEN FLUSHED IN ACCORDANCE WITH THE BOILER MANUFACTURER'S INSTRUCTIONS?

THE SYSTEM CLEANER USED \_\_\_\_\_

THE INHIBITOR USED \_\_\_\_\_

### FOR THE CENTRAL HEATING MODE, MEASURE & RECORD

GAS RATE  m<sup>3</sup>/hr  ft<sup>3</sup>/hr

BURNER OPERATING PRESSURE (IF APPLICABLE)  N/A  mbar

CENTRAL HEATING FLOW TEMPERATURE  °C

CENTRAL HEATING RETURN TEMPERATURE  °C

### FOR COMBINATION BOILERS ONLY

HAS A WATER SCALE REDUCER BEEN FITTED? YES  NO

WHAT TYPE OF SCALE REDUCER HAS BEEN FITTED? \_\_\_\_\_

### FOR THE DOMESTIC HOT WATER MODE, MEASURE & RECORD

GAS RATE  m<sup>3</sup>/hr  ft<sup>3</sup>/hr

MAXIMUM BURNER OPERATING PRESSURE (IF APPLICABLE)  N/A  mbar

COLD WATER INLET TEMPERATURE  °C

HOT WATER OUTLET TEMPERATURE  °C

WATER FLOW RATE  lts/min

### FOR CONDENSING BOILERS ONLY CONFIRM THE FOLLOWING

THE CONDENSATE DRAIN HAS BEEN INSTALLED IN ACCORDANCE WITH THE MANUFACTURER'S INSTRUCTIONS? YES

### FOR ALL INSTALLATIONS CONFIRM THE FOLLOWING

THE HEATING AND HOT WATER SYSTEM COMPLIES WITH CURRENT BUILDING REGULATIONS

THE APPLIANCE AND ASSOCIATED EQUIPMENT HAS BEEN INSTALLED AND COMMISSIONED IN ACCORDANCE WITH THE MANUFACTURER'S INSTRUCTIONS

IF REQUIRED BY THE MANUFACTURER, HAVE YOU RECORDED A CO/CO<sub>2</sub> RATIO READING? N/A  YES  CO/CO<sub>2</sub> RATIO

THE OPERATION OF THE APPLIANCE AND SYSTEM CONTROLS HAVE BEEN DEMONSTRATED TO THE CUSTOMER

THE MANUFACTURER'S LITERATURE HAS BEEN LEFT WITH THE CUSTOMER

**COMMISSIONING ENG'S NAME** PRINT \_\_\_\_\_ CORGI ID No. \_\_\_\_\_

SIGN \_\_\_\_\_ DATE \_\_\_\_\_

# SERVICE INTERVAL RECORD

It is recommended that your heating system is serviced regularly and that you complete the appropriate Service Interval Record Below.

**Service Provider.** Before completing the appropriate Service Interval Record below, please ensure you have carried out the service as described in the boiler manufacturer's instructions. Always use the manufacturer's specified spare part when replacing all controls

**SERVICE 1** DATE \_\_\_\_\_  
ENGINEER NAME \_\_\_\_\_  
COMPANY NAME \_\_\_\_\_  
TEL No. \_\_\_\_\_  
CORGI ID CARD SERIAL No. \_\_\_\_\_  
COMMENTS \_\_\_\_\_  
SIGNATURE \_\_\_\_\_

**SERVICE 2** DATE \_\_\_\_\_  
ENGINEER NAME \_\_\_\_\_  
COMPANY NAME \_\_\_\_\_  
TEL No. \_\_\_\_\_  
CORGI ID CARD SERIAL No. \_\_\_\_\_  
COMMENTS \_\_\_\_\_  
SIGNATURE \_\_\_\_\_

**SERVICE 3** DATE \_\_\_\_\_  
ENGINEER NAME \_\_\_\_\_  
COMPANY NAME \_\_\_\_\_  
TEL No. \_\_\_\_\_  
CORGI ID CARD SERIAL No. \_\_\_\_\_  
COMMENTS \_\_\_\_\_  
SIGNATURE \_\_\_\_\_

**SERVICE 4** DATE \_\_\_\_\_  
ENGINEER NAME \_\_\_\_\_  
COMPANY NAME \_\_\_\_\_  
TEL No. \_\_\_\_\_  
CORGI ID CARD SERIAL No. \_\_\_\_\_  
COMMENTS \_\_\_\_\_  
SIGNATURE \_\_\_\_\_

**SERVICE 5** DATE \_\_\_\_\_  
ENGINEER NAME \_\_\_\_\_  
COMPANY NAME \_\_\_\_\_  
TEL No. \_\_\_\_\_  
CORGI ID CARD SERIAL No. \_\_\_\_\_  
COMMENTS \_\_\_\_\_  
SIGNATURE \_\_\_\_\_

**SERVICE 6** DATE \_\_\_\_\_  
ENGINEER NAME \_\_\_\_\_  
COMPANY NAME \_\_\_\_\_  
TEL No. \_\_\_\_\_  
CORGI ID CARD SERIAL No. \_\_\_\_\_  
COMMENTS \_\_\_\_\_  
SIGNATURE \_\_\_\_\_

**SERVICE 7** DATE \_\_\_\_\_  
ENGINEER NAME \_\_\_\_\_  
COMPANY NAME \_\_\_\_\_  
TEL No. \_\_\_\_\_  
CORGI ID CARD SERIAL No. \_\_\_\_\_  
COMMENTS \_\_\_\_\_  
SIGNATURE \_\_\_\_\_

**SERVICE 8** DATE \_\_\_\_\_  
ENGINEER NAME \_\_\_\_\_  
COMPANY NAME \_\_\_\_\_  
TEL No. \_\_\_\_\_  
CORGI ID CARD SERIAL No. \_\_\_\_\_  
COMMENTS \_\_\_\_\_  
SIGNATURE \_\_\_\_\_

**SERVICE 9** DATE \_\_\_\_\_  
ENGINEER NAME \_\_\_\_\_  
COMPANY NAME \_\_\_\_\_  
TEL No. \_\_\_\_\_  
CORGI ID CARD SERIAL No. \_\_\_\_\_  
COMMENTS \_\_\_\_\_  
SIGNATURE \_\_\_\_\_

**SERVICE 10** DATE \_\_\_\_\_  
ENGINEER NAME \_\_\_\_\_  
COMPANY NAME \_\_\_\_\_  
TEL No. \_\_\_\_\_  
CORGI ID CARD SERIAL No. \_\_\_\_\_  
COMMENTS \_\_\_\_\_  
SIGNATURE \_\_\_\_\_





# Gledhill (Water Storage) Ltd

AMD, JUNE 2008

## CONDITIONS OF SALE & GUARANTEE TERMS

1. Gledhill (Water Storage) Ltd ("We" or "Gledhill") only do business upon the Conditions which appear below and no other. Unless we so agree in writing these Conditions shall apply in full to any supply of goods by us to the satisfaction of any Conditions or terms sought to be imposed by any purchaser. These Conditions of Sale and Warranty Terms override those which are contained on the Invoice Forms and all Sales are made subject to these Conditions of Sale and Warranty Terms only.

### 2. PRICE

Once an order or call off has been accepted the price will be held for three months but if delivery is estimated beyond that period at the customer's request, then we reserve the right to amend the price when necessary. The company reserves its pricing normally to adjust for changes in our cost base. We reserve the right to alter prices at any time to cover movements in raw materials (notably copper and steel). If there is to be a change we will give customers at least four weeks notice but anything delivered after that date will be at the revised price. An order may not be cancelled or varied after acceptance without the written consent of the company. Such cancellation or variation shall be subject to such acceptable changes as may be appropriate.

### 3. SPECIFICATION

The goods are supplied in accordance with the Specifications (if any) submitted to the Purchaser and any additions and alterations shall be the subject of an extra charge. Any goods not as specified shall be in accordance with our printed literature or the literature of any of our component suppliers subject to any modifications made there public alike. If we accept any changes in construction or design of the goods, or in the specifications printed in our literature, the Purchaser shall accept the goods as changed in fulfillment of the order.

### 4. PAYMENT

The Invoice price of goods shall be payable within 30 days of dispatch by us of our Invoice for the goods or such longer time as may be stated by our quotation or Invoice. If we receive payment in full or before the due date we will allow an appropriate settlement discount except where we have quoted a special net price. If payment is not received in full or before the due date we shall be entitled in addition to the Invoice price to:

- (i) payment of a sum equal to any increase in the copper price supplement applicable to the particular goods said between the date of receipt of order and the date of receipt of payment in full; and
- (ii) interest on any part of the Invoice price unpaid after the due date at the rate of 3% per annum over the base rate for the time being of HSBC Bank plc.

### 5. TITLE

We give estimates of delivery dates in good faith and time of delivery is not set shall be scale of the nature of any contract nor shall we be liable for any loss or damage occasioned by delay in delivery.

### 6. DELIVERY

We deliver normally by our own vehicles within 25 miles of any of our manufacturing depots. Delivery to any place more than 25 miles from one of our manufacturing depots may be subject to our special delivery charges. We reserve the right to make delivery of goods contained in one order by more than one consignment and at different times. Where a period is agreed for delivery and such period is not complied by our Agreement, the Purchaser shall take delivery within that period. If the Purchaser fails to take delivery, we shall be entitled at the Purchaser's risk and expense to store the goods at the Purchaser's premises or elsewhere and to demand payment as if they had been despatched. Off loading at point of delivery shall be the responsibility of and to undertake by the Purchaser.

### 7. INSURANCE OR DAMAGE

Goods sent by Inland water shall be at the risk of the carrier and any damage, shortage or discrepancy noted on the delivery note and the goods returned on the same vehicle. The buyer must also give us immediate written notice of the damage, shortage or discrepancy so that we may prompt investigation.

### 8. RETURN OF GOODS

Goods may not be returned to the Company except by prior written permission of an authorized officer of the Company and such return shall be subject to payment by the Purchaser of handling and re-stocking charges, transport and all other costs incurred by the Company.

### 9. COMPANY LIABILITY AND GUARANTEE

9.1. Subject to the terms of these Conditions of Sale and General or Terms Gledhill provide Guarantee in respect of specific products as set out in this clause.

9.2. Each Guarantee is strictly conditional upon the following:

9.2.1. Complaints must be given to us immediately, before any action is taken, as responsibility cannot be accepted if repairs or reworks are attempted on site without our written approval.

9.2.2. The unit has been installed in accordance with manufacturer and service instructions and all relevant codes of practice and regulations in force at the time of installation.

9.2.3. All necessary inlet controls and safety valves have been fitted correctly.

9.2.4. The unit has only been used for the storage of potable water supplied from the public mains.

9.2.5. Where appropriate the unit has been regularly maintained as detailed in the installation and service instructions.

9.2.6. Defects caused by corrosion or scale deposits are not covered by any Guarantee.

9.2.7. Where we agree to modify any detail we reserve the right to undertake the work on our own premises.

9.3. Guarantees are provided in respect of specified goods supplied by Gledhill as follows:-

(a) Domestic and Commercial Open Venting Cylinders and Tanks  
The copper storage vessel is guaranteed for ten years and if it proves to be defective either in materials or workmanship, we will either repair or supply replacement at our option with the closest substitute in the case of any obsolete product to any address in Great Britain.

(i) Free of all charge during the first year after delivery by us.

(ii) Thereafter at a charge of one-tenth of the then current list price and any copper price supplement and delivery charge during the second year after delivery by us and increasing by a further one-tenth on the second and subsequent anniversary of delivery by us.

(b) Domestic Inlet and Pressure (Primary) Valves

The copper storage vessel is guaranteed for five years and if it or any integral pipework as part of the storage vessel assembly proves to be defective either in materials or workmanship, we reserve the right to either repair or supply replacements or the closest possible substitute in the case of any obsolete product and will collect and deliver to any address in England, Wales and Scotland (including all Scottish Islands).

(i) Free of all charge during the first year after delivery by us.

(ii) Thereafter at a charge of one-tenth of the then current list price or any copper price supplement and delivery charge during the second year after delivery by us increasing by a further one-tenth on the second and subsequent anniversary of delivery by us.

(c) Integrated Inlet and Storage Vessel Products and Stand Alone Inlets

In the case of the full-house range of products and the Gledhill Inlet range of products, Gledhill guarantees as the best manufacturer (factory) for materials and construction costs for two years. THE RESPONSIBILITY FOR THE EXECUTION OF THIS GUARANTEE LIES WITH THE INSTALLER.

The guarantee becomes null and void if the appliance is used incorrectly, or in the event of proven negligence or incorrectly implemented repairs OR FAILURE TO CHECK GUY THE RECOMMENDED INSTALLATION MAINTENANCE. The guarantee also becomes null and void if changes are made to the appliance without our knowledge, or if the serial number on the appliance is removed or made illegible.

The annual service must be carried out by a competent installer in accordance with the advice given by Gledhill and using Gledhill approved parts.

(d) Maximum Hot Watered Cylinders  
Gledhill guarantees the components including controls, valves and electrical parts for two years from the date of purchase. IT SHOULD BE NOTED THAT THE FACTORY FITTED TEMPERATURE AND PRESSURE RELIEF VALVE MUST NOT BE REMOVED OR ALTERED IN ANY WAY OR THE GUARANTEE WILL NOT BE VALID. GLEDHILL WILL NOT BE RESPONSIBLE FOR ANY CONSEQUENTIAL LOSS OR DAMAGE HOWEVER IT IS CAUSED.

The guarantee for the stainless steel vessel is for twenty five years if the unit is returned to us UNENCHARGED:-

(i) If it has been installed as per the Design, Installation & Servicing Instructions, relevant standards, regulations and codes of practice.

(ii) If it has not been modified, other than by Gledhill.

(iii) If it has not been subjected to misuse or improper use or left unattended for.

(iv) If it has only been used for the storage of potable water.

(v) If it has not been subjected to frost damage.

(vi) The benchmark log book is completed after each annual service.

(vii) The unit has been serviced annually.

It should be noted that the guarantee does not cover:-

- The effects of scale build up

- Any labour charges associated with replacing the unit or parts.

If the stainless steel vessel proves to be defective either in materials or workmanship we reserve the right to either repair or supply replacements or the closest possible substitute in the case of any obsolete product and will collect and deliver to any address in England, Scotland and Wales (including all Islands).

(i) Free of charge during the first year after delivery by us.

(ii) Thereafter at a charge of one-tenth of the then current list price and any copper price supplement and delivery charge during the second year after delivery by us and increasing by a further one-tenth on the second and subsequent anniversary of delivery by us.

### ACTION IN THE EVENT OF FAILURE

If the stainless steel cylinder develops a leak we will either a) replace or b) repair the supply of a new one. This will be subject to the failure is within the terms of the warranty when it has been accepted by us.

(a) Boiler Pumps and auxiliary equipment

Gledhill provides a five year warranty for defects in the collector (except broken glass and collector accessories eg metal splashes). If the collector demonstrably fails to meet one of the requirements of the standard BS1457 part 3 we will replace it free of charge based on the date of invoice. We can not be responsible for damage caused by mechanical stress and/or damage caused by weather related influences. The warranty excludes other surface damage that does not affect performance or installation also in improper assembly or installation.

### Please note

- Installation used have been carried out by a licensed specialist company (installing contractor or plumber) following the version of installation instructions in force.

- Gledhill or its representative has given the opportunity to check, complete an site immediately after any defect occurred.

- Installation notes that the system was commissioned properly and that the system was checked and maintenance was performed annually by a specialist company licensed for this purpose.

(b) Components of our products other than Storage Vessels and Inlet Pipework.

We will either attend in the purchaser the same terms of warranty as we are given by the manufacturer of the component or if the manufacturer does not give any warranty, replace free of charge any component which becomes defective within two years after the date of the delivery by us and is returned to us at the purchaser's expense but we shall not meet the cost of removal or shipping or return of the component or any other cost charge or damage incurred by the purchaser.

If the appliance manufactured by Gledhill incorporates a factory fitted scale inhibitor then during the period

of these years from the date of delivery. Goodwill will replace, free of charge, any plate heat exchanger fitted to the appliance as original equipment in which a scale description occurred, substantially reduces the effectiveness of the plate heat exchanger. This guarantee does not extend to any other component installed within the Goodwill appliance or elsewhere in the Purchaser's domestic water system.

**9.8.**

**9.8.1.** In respect of goods supplied by us and in respect of any installation work carried out by or on our behalf, our entire liability and the purchaser's sole remedy (subject to the Guarantees) shall be as follows:-

- (a) We accept liability for death or personal injury to the extent that it results from our negligence or that of our employees;
- (b) Subject to the other provisions of this clause 9 we accept liability for direct physical damage to tangible property to the extent that such damage is caused by our negligence or that of our employees, agents or sub-contractors;
- (c) Our total liability to the purchaser over and above any liability in respect of the Guarantees (whether in contract or in tort including negligence) in respect of any one claim of loss or damage claimed to result from any breach of our obligations hereunder, shall be limited to actual monetary damages which shall not exceed £25,000 provided that such monetary limit shall not apply to any liability on the part of ourselves referred to in paragraph (a) above;
- (d) Except as provided in paragraphs (a) above but otherwise notwithstanding any provision herein contained in no event shall we be liable for the following loss or damage to ourselves caused and over if then actionable by us or in our contemplation:
  - (i) economic loss which includes loss of profits, business revenues, goodwill or anticipated savings;
  - (ii) damage in respect of special interest or consequential loss or damage (other than death, personal injury and damage to tangible property);
  - (iii) any claim made against the purchaser by any other party (save as expressly provided in paragraph (b) above);
- (e) Except in respect of our liability referred to in paragraph (a) above no claim may be made or action brought (whether in contract or in tort including negligence) by the purchaser in respect of any goods supplied by us more than one year after the date of the invoice for the relevant goods;
- (f) Without prejudice to any other term we shall not be liable for any other damage caused directly or indirectly as a result of any loss or other defect in the goods. We cannot control the condition of use of the goods or the time or manner or location in which they will be installed and the purchaser agrees to be fully responsible for fitting and the checking of vents which include the goods at all relevant times (a) to, including and after commencing) and for taking all necessary steps to identify any loss and prevent any damage being caused thereby;
- (g) Nothing in these Conditions shall confer on the purchaser any rights or remedies in which the purchaser would not otherwise be legally entitled.

**10. LIMIT OF LIABILITY**

Notwithstanding any other provision contained herein the purchaser hereby agrees to fully indemnify us against any damage, losses, costs, claims or expenses incurred by us in respect of any claim brought against us by any third party (a) :-

- (a) any loss, injury or damage wholly or partly caused by any goods supplied by us or their use;
- (b) any loss, injury or damage wholly or partly caused by the defective installation or substantial non-compliance or maintenance used in the installation of any goods supplied by us;
- (c) any loss, injury or damage in any way connected with the performance of this contract;
- (d) any loss resulting from any failure by the purchaser to comply with its obligations under these terms as to installation and/or check, vents correctly.

**PROVIDED** that this paragraph will not require the purchaser to indemnify us against any liability for our own acts of negligence or those of our employees or agents or sub-contractors.

**FURTHER** in the case of goods supplied by us which are re-sold or distributed by a third party the purchaser will be the sole responsibility of the purchaser to take the goods immediately after their installation to ensure that later alterations are correctly installed and in proper working order from the date and are not likely to cause any loss, injury or damage in any person or property.

**11. VALIDATION OF NECESSARY AND REASONABLE**

Should our warranty and schedule be unacceptable you are prepared to negotiate for variation in their terms but only on the basis of an increase in the price to allow for any additional liability or risk which may result from the variation.

Purchasers are advised to insure against any risk or liability which they may incur and which is not covered by our warranty.

**12. TITLE AND RETENTION OF TITLE**

- (a) Goods supplied by us shall be at the Purchaser's risk immediately upon delivery to the Purchaser or into custody on the Purchaser's behalf or in the Purchaser's name. The Purchaser shall effect adequate insurances of the goods against all risks to the full invoice value of the goods, such insurances to be effective from the time of delivery until property in the goods shall pass to the Purchaser as hereinafter provided.
- (b) Property in the goods supplied hereunder will pass to the Purchaser when full payment has been made by the Purchaser to us (a) :-
  - (i) the goods of the subject of this contract;
  - (ii) all other goods the subject to of any other contract between the Purchaser and us which, at the time of payment of the full price of the goods sold under this contract, have been delivered to the Purchaser but not paid for in full.
- (c) until property in the goods supplied hereunder passes to the Purchaser in accordance with paragraph (b) above:
  - (i) the Purchaser shall hold the goods in a fiduciary capacity for us and shall show the same separately from any other goods in the Purchaser's premises and in a manner which enables them to be identified as our goods;
  - (ii) the Purchaser shall immediately return the goods to us should our self-named representative so request. All the necessary incidents associated with a fiduciary relationship shall apply.
- (d) the Purchaser's rights in possession of the goods shall cease forthwith upon the happening of any of the following events, namely :-
  - (i) if the Purchaser fails to make payment in full for the goods within the time stipulated in clause 4 hereof;
  - (ii) if the Purchaser, not being a company, commits any act of bankruptcy, makes a proposal to its or her creditors for a composition or does anything which would entitle a petition for a Bankruptcy Order to be presented;
  - (iii) if the Purchaser, being a company, does anything or fails to do anything which would entitle an administrator or an administrative receiver or a receiver to take possession of any assets or which would entitle any person in possession a petition for winding up or to apply for an administration order;
- (e) the Purchaser hereby grants to us an irrevocable licence to enter at any time any vehicle or premises owned or occupied by the Purchaser or in the possession of the Purchaser for the purposes of repossessing and

recovering any such goods the property in which has remained in us under paragraph (b) above. We shall not be responsible for and the Purchaser will indemnify us against liability in respect of damage caused in any vehicle or premises in such repossession and removal being damaged which it was not reasonably practicable to avoid.

- (f) notwithstanding paragraph (b) hereof and subject to paragraph (7) hereof, the Purchaser shall be permitted to sell the goods to third parties in the normal course of business. In this regard the Purchaser shall act in the capacity of our commission agent and the proceeds of such sale :-

- (i) shall be held in trust for us in a manner which enables such proceeds to be identified as such; and
- (ii) shall not be mixed with other monies or paid into an overdraft bank account.

We, as principal, shall reimburse the Purchaser as commission agent a commission depending upon the profit which the Purchaser can obtain over and above the sum, stipulated in this contract of supply which will satisfy us.

- (g) in the event that the Purchaser shall sell any of the goods provided to clause (b) hereof, the Purchaser shall forthwith inform us in writing of such sale and of the identity and address of the third party to whom the goods have been sold.

- (h) if, before property in the goods passes to the Purchaser under paragraph (b) above the goods are or become affixed to any land or building owned by the Purchaser it is hereby agreed and declared that such affixation shall not have the effect of passing property in the goods to the Purchaser. Furthermore if, before property in the goods shall pass to the Purchaser under paragraph (b) hereof, the goods are or become affixed to any land or building (whether or not owned by the Purchaser), the Purchaser shall :-

- (i) ensure that the goods are capable of being removed without material injury to such land or building;
- (ii) take all necessary steps to prevent title to the goods from passing to the tenant of such land or building;
- (iii) forthwith inform us in writing of such affixation and of the address of the land or building concerned.

The Purchaser warrants to repair and make good any damage caused by the affixation of the goods to or their removal from any land or building and to indemnify us against all loss, damage or liability we may incur or sustain as a result of affixation or removal.

- (i) in the event that, before property in the goods has passed to the Purchaser under paragraph (b) hereof, the goods or any of them are lost, stolen, damaged or destroyed :-

- (a) the Purchaser shall forthwith inform us in writing of the fact and circumstances of such loss, theft, damage or destruction;
- (b) the Purchaser shall assign to us the benefit of any insurance claims in respect of the goods so lost, stolen, damaged or destroyed.

**13. NON-PAYMENT**

If the Purchaser shall fail to make full payment for the goods supplied hereunder within the time stipulated in clause 4 hereof or to its default of payment for any other reason then, without prejudice to any of our other rights hereunder, we shall be entitled to stop all deliveries of goods and materials to the Purchaser, including deliveries or further deliveries of goods under this contract. In addition we shall be entitled to terminate all outstanding orders.

**14. VALUE ADDED TAX**

All prices quoted are exclusive of Value Added Tax which will be charged at the rate ruling at the date of dispatch of invoice.

**15. WHOLESALE ONLY**

We are only prepared to deal with those who are not consumers within the terms of the Unfair Contract Terms Act 1977, the Sale of Goods Act 1979 and the Supply of Goods and Services Act 1982. Accordingly any person who purchases from us shall be deemed to have represented that he is not a consumer by so purchasing.

**16. JURISDICTION**

This agreement is subject to English law for products delivered in England and Scottish law for products delivered in Scotland and any disputes hereunder shall be settled in accordance therewith dependent upon the location.

