



The eBike Display

User Manual

KD986

Product name and model

Name: Intelligent TFT display for E-bike

Model: KD986

Specifications

- 24V/36V/48V Power Supply
- Rated working current: 50mA
- The maximum working current: 200mA
- Off-state leakage current: <math><1\mu\text{A}</math>
- Operating temperature: $-20^{\circ}\text{C}\sim 60^{\circ}\text{C}$
- Storage temperature: $-30^{\circ}\text{C}\sim 70^{\circ}\text{C}$

Appearance and Size

- ◆Display appearance and dimensional drawing (unit: mm)

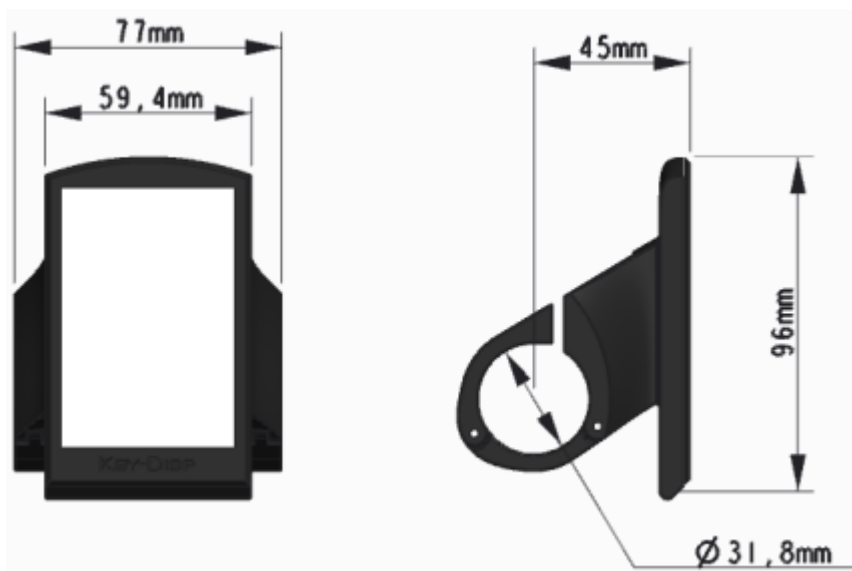

◆ Remote control appearance and dimensional drawing (unit: mm)

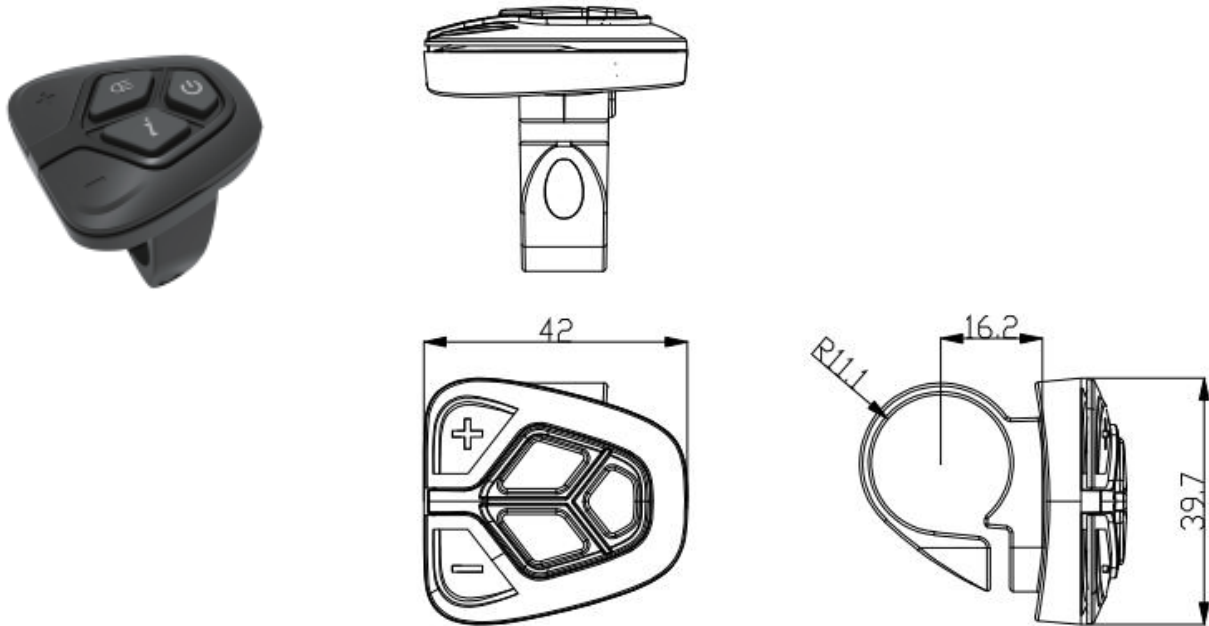

Function Summary

KD986 can provide a lot of functions to fit the Users needs. The indicating contents are as follows:

- Battery SOC percentage indication
- Motor Power indication
- Assist-level indication
- Speed indication (incl. running speed, Max. speed and Ave. speed)
- Odometer and trip distance
- The push-assistance function
- Trip time indication
- Backlight On/Off
- Error code indication
- USB connection indicator
- Various Parameters Settings (e.g., wheel size, speed limit, voltage set, assistance level, controller limited current, password enable/change/disable, etc.)

General Operation

◆ Switching the E-bike System On/Off

Briefly press the power button to switch on the E-bike system.

To hold the power button for 2s, the E-bike system will be switched off. The E-bike system no longer uses the battery power.

When switching off the E-bike system, the leakage current is less than 1 μ A.

■ When parking the E-bike for more than 10 minutes, the E-bike system switches off automatically.

◆ Display Interface

After switching on the E-bike system, the display will show Speed and Trip Distance by default. Pressing the “i” button to switch between following elements:

Trip (Km) → ODO (Km) → Max. Speed (Km/h) → Avg. Speed (Km/h) → Time (Min.) .



Display Indication Cycle Interface

◆ Switching Push-assistance Mode On/Off

To activate the push-assistance function, hold the “-” button. After 2s, The E-bike’s drive

is activated at a uniform speed of 6 Km/h while the screen displays “”. The push-assistance function is switched off as soon as you release the “-” button on the operating unit .The E-bike system stops the power output immediately.



Push-assistance Mode

■ Push-assistance function may only be used when pushing the E-bike.

Be aware of danger of injury when the wheels of the E-bike do not have ground contact while using the push-assistance function.

◆ Switching the Lighting On/Off

To switch on the headlight, hold the  button. The backlight brightness is automatically reduced. Hold the  button again, the lighting can be switched off.



Switching the Lighting Mode On/Off Interface

◆ Assist Level Selection

Briefly press "+" or "-" button to switch between assistance levels so as to change the motor output power, The default assistance level ranges from level “0” to level “5” , The output power is zero on Level “0” . Level “1” is the minimum power. Level “5” is the maximum power. When you reach “5” , press the "+" button again, the interface still shows “5” , and blinks at “5” to indicate the power highest. After the power downshift reaches “0” , press the "-" button again, the interface still shows “0” and blinks at “0” to indicate the power minimum. The default value is level “1” .



Assist Level Interface

◆ **Battery SOC Indicator**

By default, the battery SOC is displayed by percentage. The battery bar is in green color when the battery is in high voltage. When percentage is less than 20%, red square for low voltage appears and battery needs to be recharged immediately.



Battery SOC Indication Interface

◆ **Motor Power Indicator**

The power of the motor can be read via below interface



Motor Power Indication Interface

◆ **USB connection indication**

When the display is inserted into a USB external device, the display interface will show as below.



USB Connection Indication Interface

◆ **Error Code Indication**

The components of the E-bike system are continuously and automatically monitored. When an error is detected, the respective error code is indicated in text indication area.

Here is the detail message of the error code in **Attached list 1**.

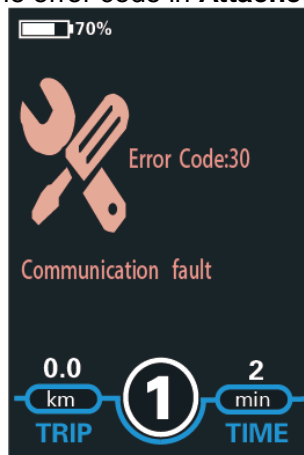

Error Code Indication

■ Have the display repaired when error code appears. Otherwise, you will not be able to ride the bike normally. Please always refer to an authorized dealer.

Setting

Press the **On/Off** button to switch on the display.
 To access Setting page, hold both the “+” button and the “-” button for 2s. **Display setting and Advanced settings**

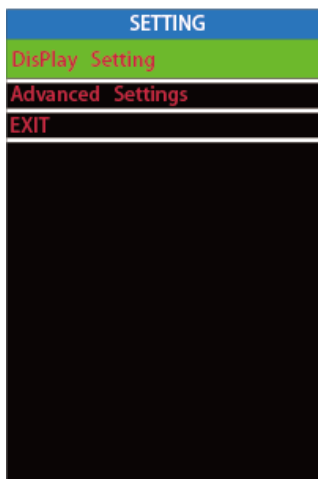

Setting interface

■ All the Settings are operated on a parked E-bike.

◆ Dormancy Settings

Dormancy represents display auto-off time settings.

To change display automatic shutdown time, press Dormancy and press the “+” button or the “-” button to choose the desired duration. The default auto-off time is 5 minutes.

To store a changed setting, briefly press the “i” button.

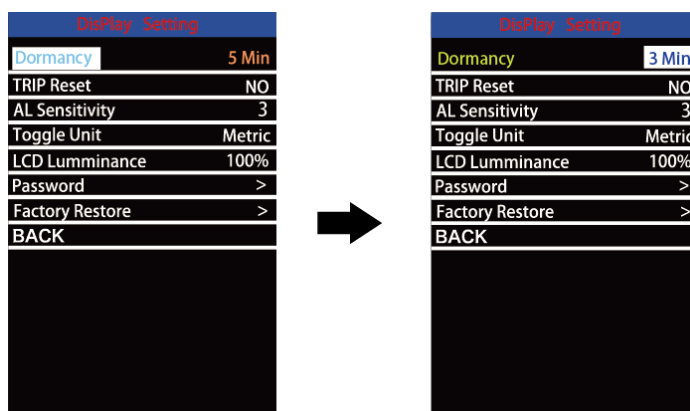

Dormancy setting interface

◆ Trip Distance Clearance

Trip Reset represents trip distance clearance setting.

To clear trip distance, press the “+” button or the “-” button to select Yes or No. Yes represents clearing a single ride distance. No represents not clearing a single ride distance.

To store a changed setting, briefly press the “i” button to confirm.

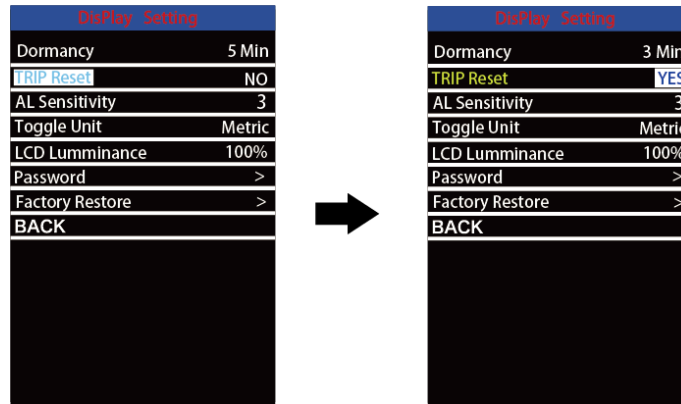

Trip Distance Clearance Settings Interface

◆AL sensitivity

AL sensitivity represents Ambient Light Sensor settings. It can help with adjusting the screen brightness as per the ambient light conditions automatically. When you ride the bike at night or in a place where there is a lack of light, the display backlight and bike light will be turned on automatically.

The sensitivity of AL sensor ranges from 1 to 5 and OFF (light sensor function is disabled). The default value is 3. Press +/- button to choose the desired sensitivity value.

To store a changed setting, briefly press the “i” button to confirm.

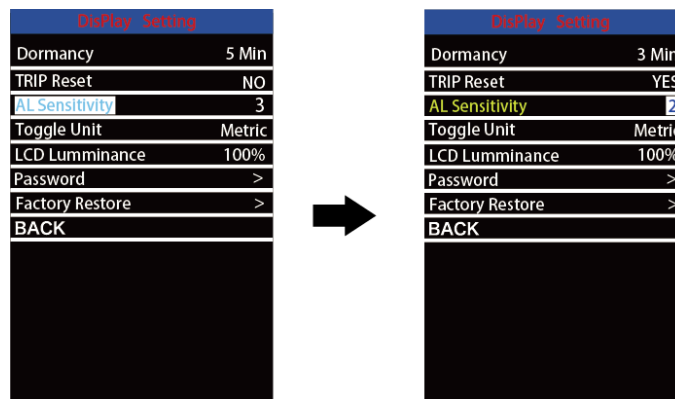

AL sensitivity setting interface

◆Unit km/mile Conversion

Toggle Unit represents unit settings.

To toggle the unit, press the “+” button or the “-” button to choose the desired unit and press the “i” button to confirm. The default unit is “Metric (km)”.

To store a changed setting, briefly press the “i” button to confirm.

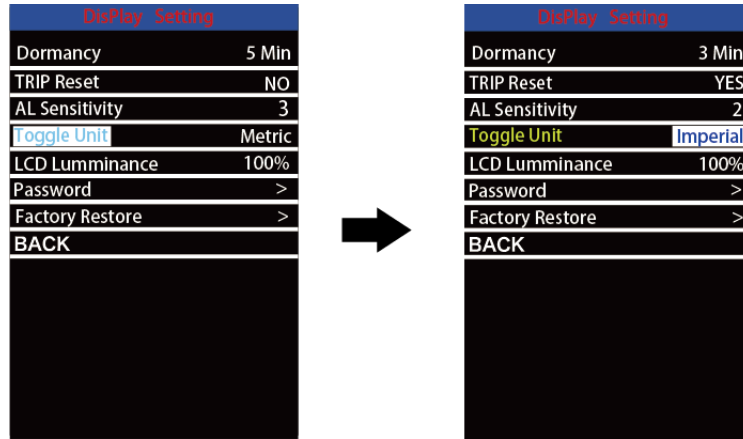

Mile and Kilometer Toggling Interface

◆LCD luminance Settings

LCD luminance represents backlight brightness settings. The less the percentage value, the lower the backlight brightness.

To change the backlight brightness, press the “+” button or the “-” button to choose the desired percentage.

To store a changed setting, briefly press the “i” button to confirm.

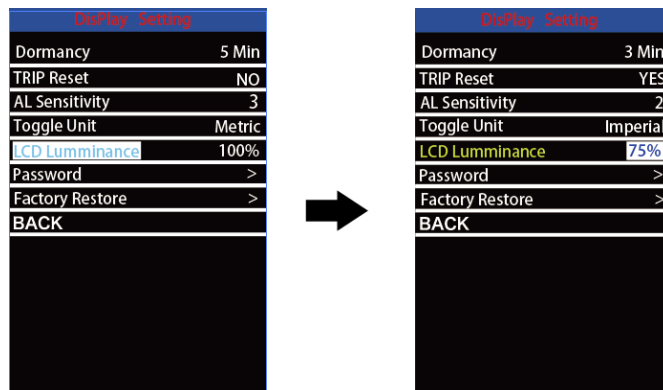

LCD luminance Settings Interface

◆Password Settings

Password means display power-on password settings

To access the power-on password setting page, select ‘**Password**’ in the menu and press “i” button to confirm.

PassWord Set means power-on password settings. Power-on password is a 4-digit code. The default password is '1212'

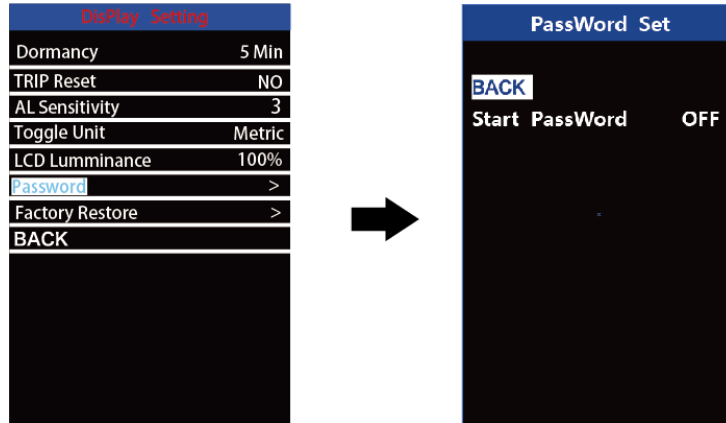

Password Setting Interface

1.Power-on Password Disable/Enable

To enable or disable **Start PassWord** settings, press the “+” or the “-” button to select ON or OFF. ON means enabling a power-on password while OFF means disabling a power-on password. The default value is OFF.

To enable a power-on password, choose ON and press “i” button to confirm and input the current password or default password'1212'. Press the “+”or the “-”button to change the number and press the “i”button to confirm digits one by one until the correct password(*current password or default password'1212'*) is completed.

To disable the current password, choose OFF and press “i” button to confirm and input the current password correctly. The screen displays 'PassWord Canceled Successfully'. ***Then the display resumes to use the default code '1212'**.



Password Enable/Disable Settings Interface

2.Power-on Password Reset

From the last interface above, press the “+” or the “-” button to select ‘Reset PassWord’ and press the “i” button to confirm to access power-on password reset interface. There are 3 pages for setting up a new password:

In the **first** page, please enter the current password or default password ‘1212’ correctly.

Then it moves to the **second** page for inputting a new password. Press the “+” or the “-” button to increase or decrease the number and then press the “i” button to confirm digits one by one until a new 4-digit password is completed.

Finally, it comes to the **third** page and reenter the new password again for confirmation. The screen displays ‘ PassWord Reset Successfully’

When switching on the E-bike system next time, please enter the new password to power on the display.

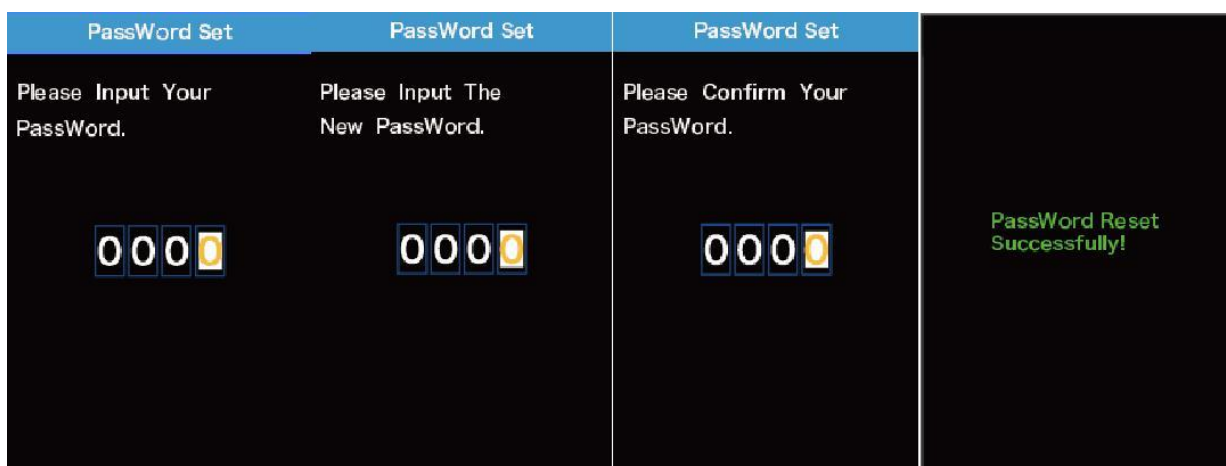

Password Change Interface

◆ Factory Defaults

Factory settings. To reset to factory defaults, press +/- to choose YES or NO. The default is NO. Press “i” button to store a changed setting.

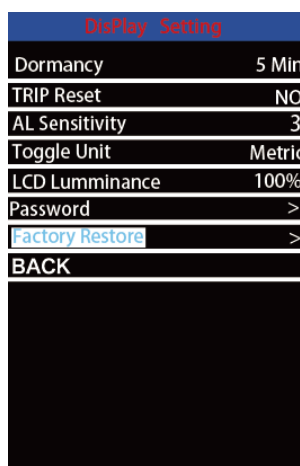

Factory defaults setting interface

Advanced setting

◆Wheel Diameter Settings

Wheel represents wheel diameter settings. To change basic settings, press the “+” or the “-” button to increase or decrease until the desired value is displayed. The default value is 28”.

To store a changed setting, press the “i” button to confirm.

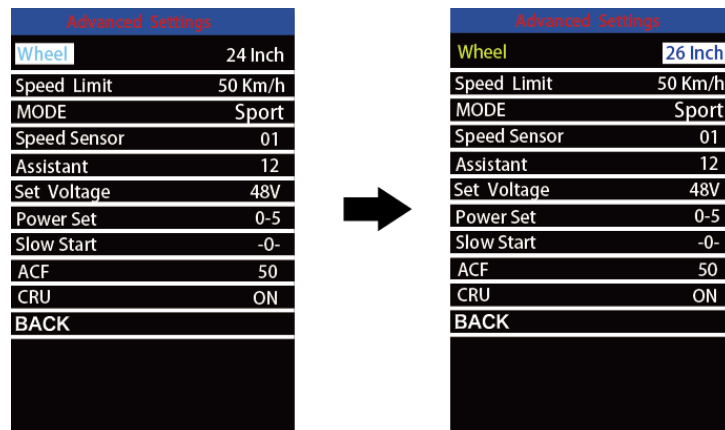

The diagram shows two screenshots of the 'Advanced Settings' menu. The left screenshot shows 'Wheel' set to '24 Inch'. The right screenshot shows 'Wheel' set to '26 Inch'. An arrow points from the left to the right, indicating the change.

Advanced Settings	
Wheel	24 Inch
Speed Limit	50 Km/h
MODE	Sport
Speed Sensor	01
Assistant	12
Set Voltage	48V
Power Set	0-5
Slow Start	-0-
ACF	50
CRU	ON
BACK	

Advanced Settings	
Wheel	26 Inch
Speed Limit	50 Km/h
MODE	Sport
Speed Sensor	01
Assistant	12
Set Voltage	48V
Power Set	0-5
Slow Start	-0-
ACF	50
CRU	ON
BACK	

◆Speed-limit Settings

Speed Limit represents the limited speed settings. When the current speed is faster than speed limit, the E-bike system will be switched off automatically. Speed limit range is 15Km/h to 99.9Km/h.

To change basic settings, press the “+” or the “-” button to increase or decrease until the desired value is displayed. Press the “i” button to confirm.

To store a changed setting, press the “i” button to confirm.

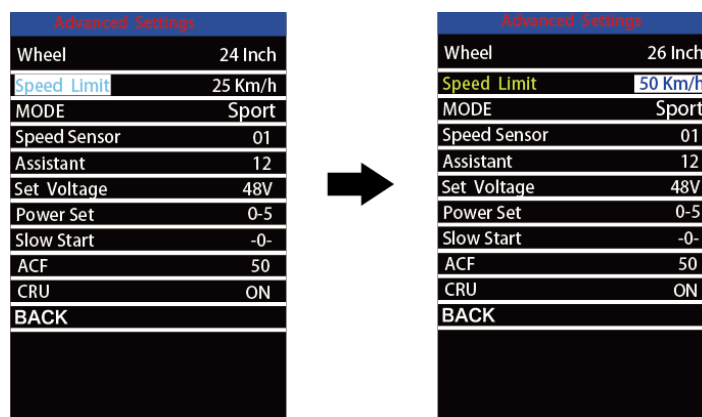

The diagram shows two screenshots of the 'Advanced Settings' menu. The left screenshot shows 'Speed Limit' set to '25 Km/h'. The right screenshot shows 'Speed Limit' set to '50 Km/h'. An arrow points from the left to the right, indicating the change.

Advanced Settings	
Wheel	24 Inch
Speed Limit	25 Km/h
MODE	Sport
Speed Sensor	01
Assistant	12
Set Voltage	48V
Power Set	0-5
Slow Start	-0-
ACF	50
CRU	ON
BACK	

Advanced Settings	
Wheel	26 Inch
Speed Limit	50 Km/h
MODE	Sport
Speed Sensor	01
Assistant	12
Set Voltage	48V
Power Set	0-5
Slow Start	-0-
ACF	50
CRU	ON
BACK	

Speed limit settings interface

◆MODE

MODE options: ECO and SPORT two options. Press +/- to change the mode option.

Sport mode: motor is in high speed running condition. Assistance response is more active with better power strength; speed pick-up is faster.

Economy mode: motor is low speed running condition. Power assist response and speed pick-up is relatively lower than sport mode. But save battery power.

Normal mode: motor is in the normal running condition. Assistance response and speed pick-up both are medium.

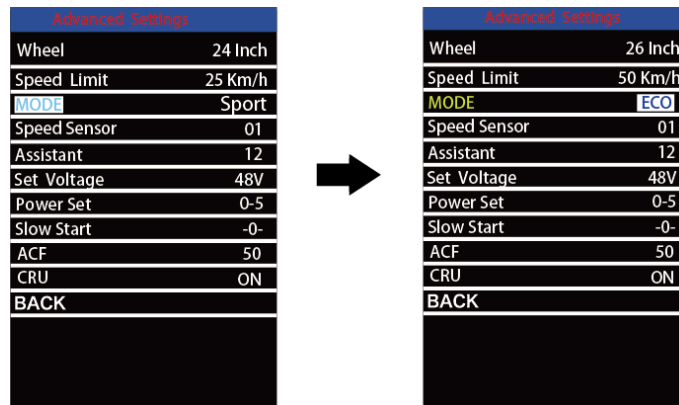

MODE setting page

◆Speed Sensor

Speed Sensor represents speed sensor settings.

To change speed sensor settings, press the “+” or the “-” button to select the quantity of magnet poles on the e-bike spoke (the range is from 1 to 15). The default value is 1.

To store a changed setting, press the “i” button to confirm.

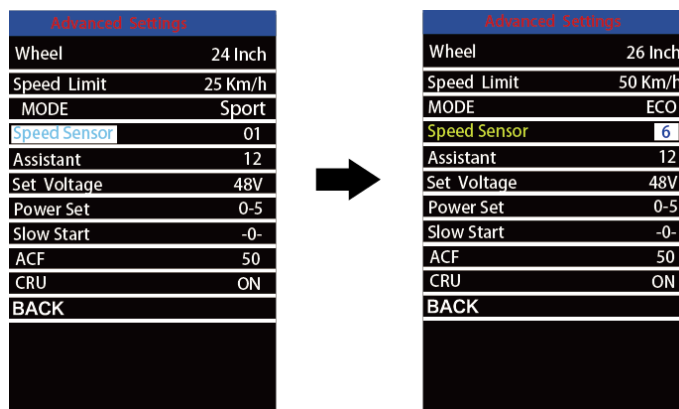

Speed sensor setting

◆Power Assistant Sensor Magnets

Assistant represents the number of magnets in the PAS disk.

To change the magnet number of power assist sensor, press the “+” or the “-” button to choose the desired number.

To store a changed setting, press the “i” button to confirm

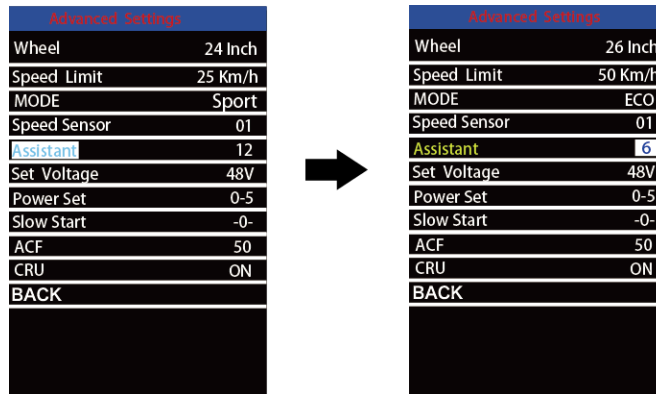

Assistant setting interface

◆Battery Power Bar Settings

Set Voltage represents battery voltage segmented value settings. 36V/48V switchable.

5 bar-voltage values for 36V or 48V must be entered one by one. Take 48V for example, “1-” is the first bar voltage value and its default value is 41.2V.

To set battery power bar value, press the “+” or the “-” button to increase or decrease the voltage values.

To store a changed setting and access the next bar voltage setting, press the “i” button.

In the same manner, after 5 bar-voltage values are entered completely, press the “i” button to confirm.

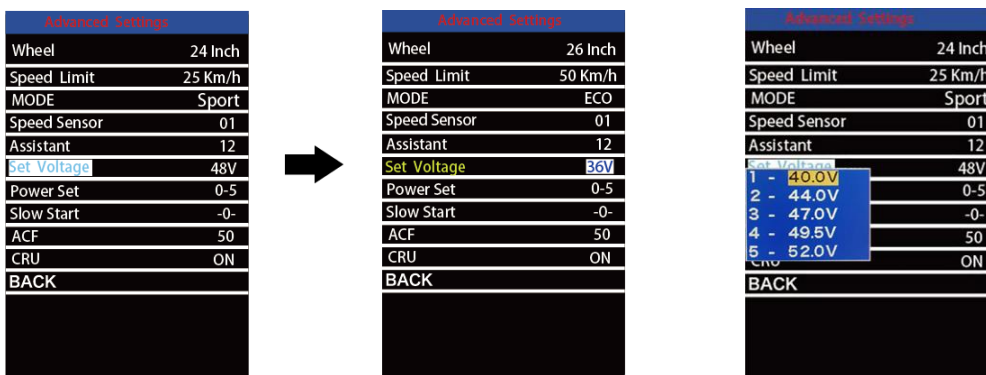

Battery Voltage Settings Interface

◆Assist Level Settings

Assist Level Mode Options

Power Set represents assist level settings. In assist level mode settings, there are 8 modes for your choice: 0-3, 1-3, 0-5, 1-5, 0-7, 1-7, 0-9, 1-9.

To change assist level mode, press the “+” or the “-” button to choose the desired mode and press the “i” button to confirm.

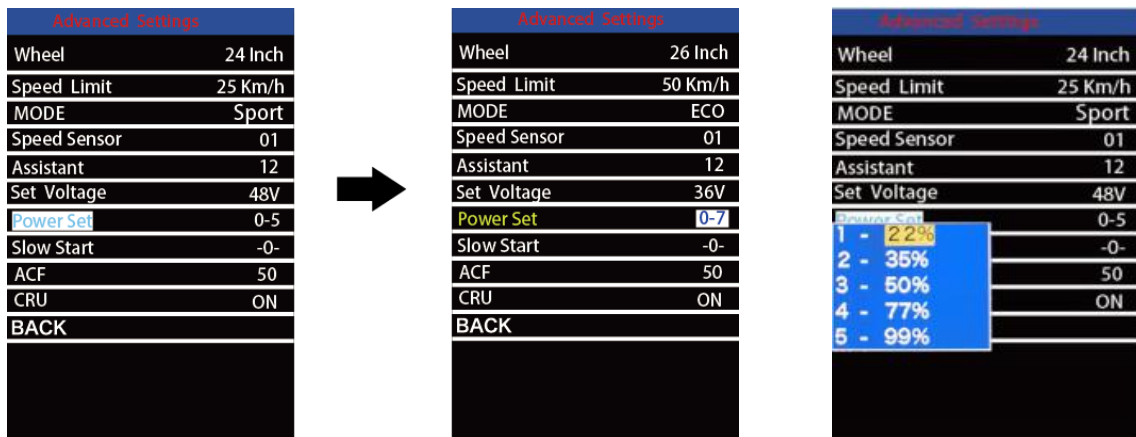

Assist Level Mode Settings Interface

◆ Slow Start

When you stepping on the pedal, it will take a certain time duration before the motor assist is engaged. This time duration setting range is 1~4. 4 is the slowest. The default value is 1. press +/- to change the slow start value and press i button to store a changed setting.

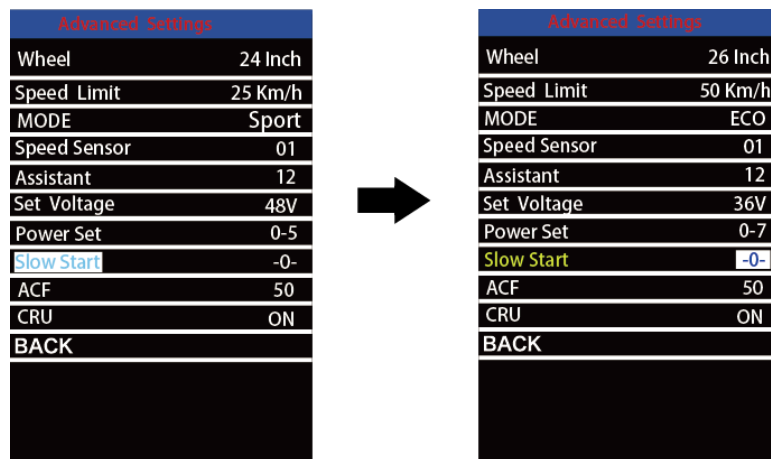

Slow start setting page

◆ ACF

ACF means charging switch setting. 0 is OFF and 50 is ON. Press +/- to change the setting and press i button to save a changed setting.

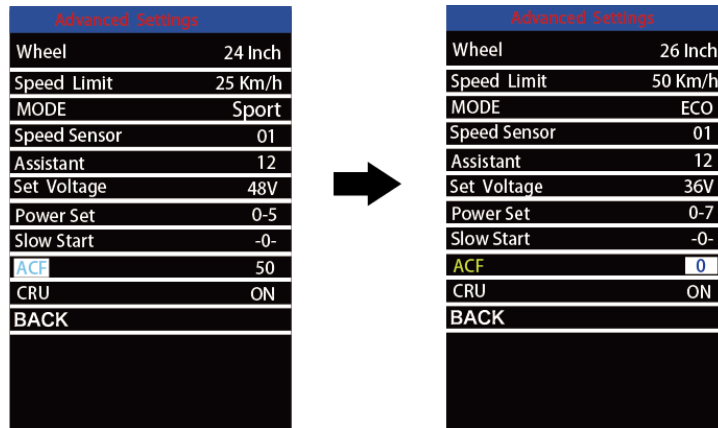

Advanced Settings	
Wheel	24 Inch
Speed Limit	25 Km/h
MODE	Sport
Speed Sensor	01
Assistant	12
Set Voltage	48V
Power Set	0-5
Slow Start	-0-
ACF	50
CRU	ON
BACK	

Advanced Settings	
Wheel	26 Inch
Speed Limit	50 Km/h
MODE	ECO
Speed Sensor	01
Assistant	12
Set Voltage	36V
Power Set	0-7
Slow Start	-0-
ACF	0
CRU	ON
BACK	

ACF setting page

◆ CRU

CRU means CRUISE function. Press +/- to switch ON/OFF the cruise mode. press i button to store a changed setting. When display keeps stable speed, you can activate the cruise mode and bike runs at a fixed speed.

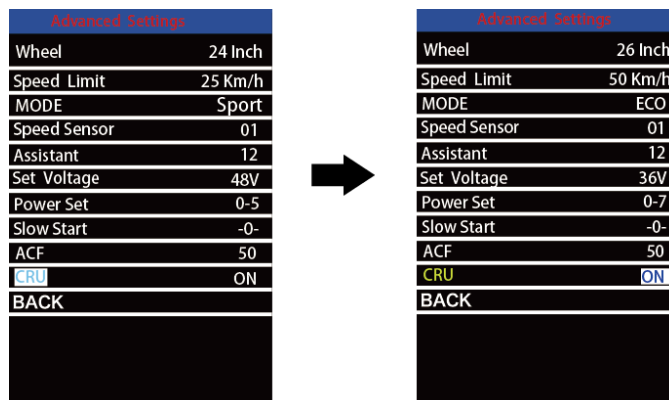

Advanced Settings	
Wheel	24 Inch
Speed Limit	25 Km/h
MODE	Sport
Speed Sensor	01
Assistant	12
Set Voltage	48V
Power Set	0-5
Slow Start	-0-
ACF	50
CRU	ON
BACK	

Advanced Settings	
Wheel	26 Inch
Speed Limit	50 Km/h
MODE	ECO
Speed Sensor	01
Assistant	12
Set Voltage	36V
Power Set	0-7
Slow Start	-0-
ACF	50
CRU	ON
BACK	

Cruise mode setting

■ If there is no setting operations in one minute; the display will exit the settings state automatically

Quality Assurance and Warranty Scope

I Warranty

- (1) The warranty will be valid only for products used in normal usage conditions.
- (2) The warranty is valid for 24 months after the shipment or delivery to customers

II The following cases do not belong to our warranty scope.

1. The display is demolished.
2. The damage of the display is caused by wrong installation or operation.
3. Shell of the display is broken when the display is out of the factory.
4. Wire of the display is broken.
5. The fault or damage of the display is caused by the force majeure (e.g., fire, earthquake, etc.).
6. Beyond Warranty period.

Connection Layout

Socket type male connector (display is cable free)

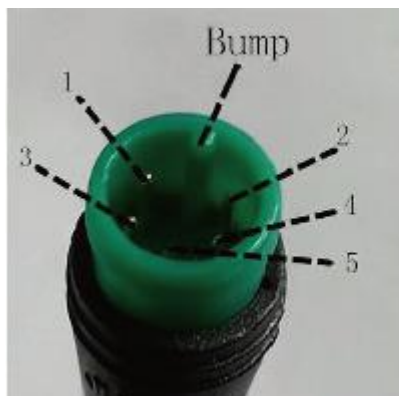

Display-side socket

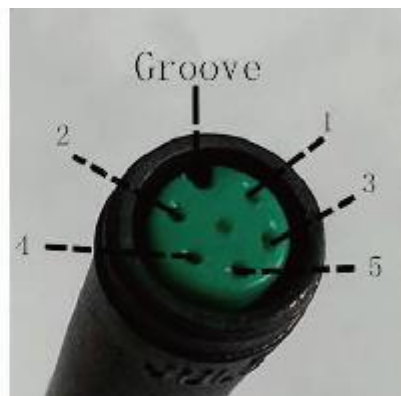

mating connector from controller side

wire sequence table

Wire no.	Color	Function
1	Red (VCC)	+
2	Blue (K)	Lock
3	Black (GND)	-
4	Green (RX)	RX
5	Yellow (TX)	TX

■Some displays have wire connection with water-proof connectors, users can not see the color of lead wires in the harness.

Warnings:

- ◆Use the display with caution. Don't attempt to release or link the connector when battery is on.
- ◆Try to avoid hitting the display.
- ◆Don't modify system parameters to avoid parameter disorder.
- ◆Make the display repaired when error code appears.

This manual instruction is a universal version for **DISPLAY KD986. Some versions of this display may be different from specification to specification as to the software. Please always refer to an actual version.*

Attached list 1: Error code definition

Error Code	Definition
21	Current Abnormality
22	Throttle Abnormality
23	Motor Phase Abnormality
24	Motor Hall Signal Abnormality
25	Brake Abnormality
30	Communication Abnormality