



Assembly Instructions

Table with 4 Backed Benches



*Thank you for choosing **A&L Furniture Co.***

We hope that this piece brings you many years of enjoyment!

For help with assembling your furniture,
or if you have missing hardware, please email us at
help@aandlfurniture.com or call us at 866-896-5747

PARTS (included)

(A) Table Top (1)

(B) Table Legs (2)

(C) Table Braces (2)

(D) Bench Tops (4)

(E) Bench Legs (8)

(F) Bench Braces (8)

(G) Bench Backs (4)



HARDWARE (included)

2³/₄" Bolts (28)

2¹/₂" Lag Screws (28)

Allen Wrench (1)

(a)

(b)

(c)



TOOLS NEEDED

Hammer

⁷/₁₆" Wrench or Socket

STEP 1

Lay the table top upside down on a clean flat surface. Attach the table legs to the inside of the 2x2 cross supports on the table top. (See photo 1.) Insert the 2³/₄" bolts through the holes in the table legs and turn them into the metal inserts in the 2x2's. (See photo 2.) Tighten with the Allen wrench. **Do not overtighten!**

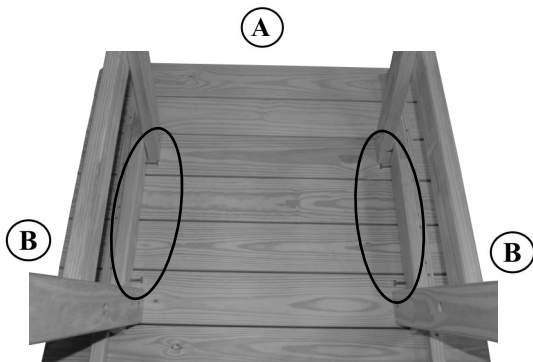

Photo 1

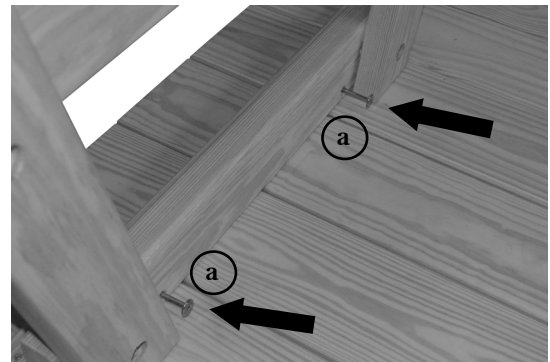

Photo 2

STEP 2

Attach the table braces with one end of the braces against the table top and the other end against the horizontal crosspiece on the table leg. (See photo 3.) Insert the 2¹/₂" lag screws through the holes in the braces. (See photo 4.) Tap them lightly with the hammer to start them into the wood. They are self drilling and will not crack the wood. Tighten them with the ⁷/₁₆" wrench or socket. **Do not overtighten** as this may cause them to break!

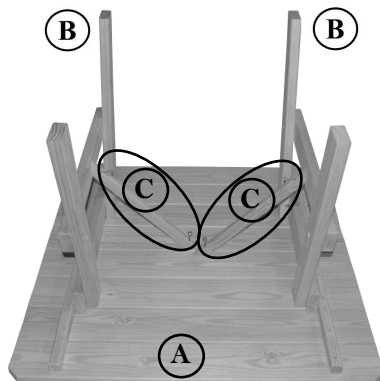

Photo 3

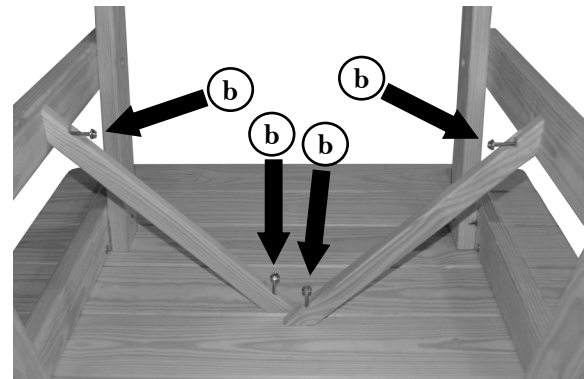

Photo 4

STEP 3

Lay the bench seat upside down on a clean flat surface. Place the bench legs outside of the 2x2 cross supports on the bench seat. (See photo 5.) If the holes do not align they can be adjusted by pushing/pulling at the leg with your hands. Insert 2³/₄" bolts through the holes in the bench legs (see photo 6) and turn them into the metal inserts in the 2x2. Tighten with the Allen wrench being careful not to overtighten.

Note: If the bench rocks when you set it upright, loosen the bolts, put some weight on the bench and retighten.

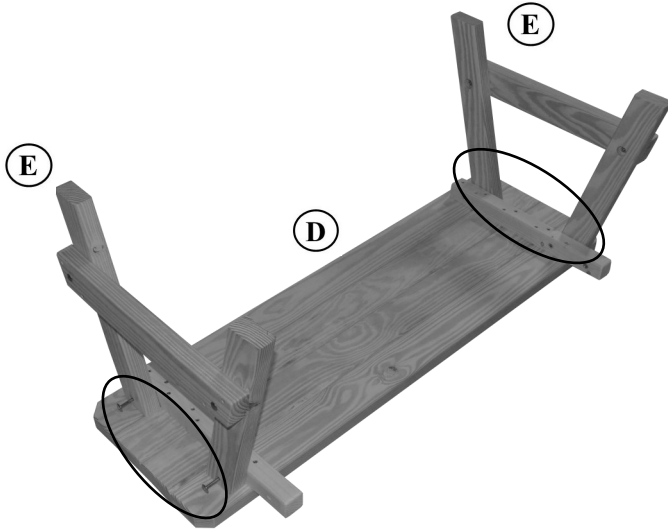

Photo 5

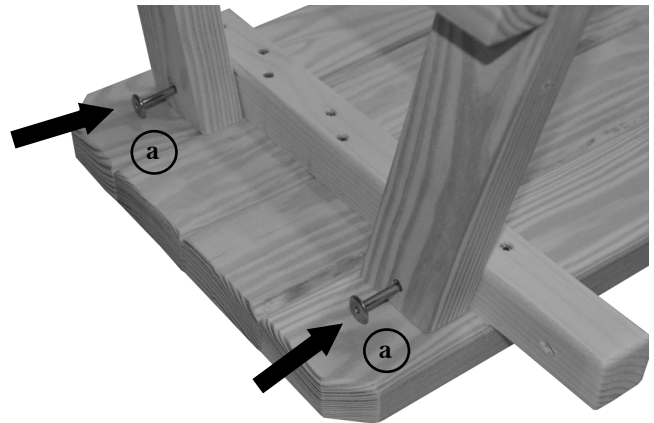

Photo 6

STEP 4

Attach the bench braces placing one end of the brace against the bench top and the other end against the horizontal crosspiece on the bench leg. Be sure to stay to one side of the crack between the boards. (See photo 7.) Insert 2¹/₂" lag screws through the holes in the bench braces. (See photo 8.) Tap them lightly with the hammer to start them into the wood. They are self drilling and will not crack the wood. Tighten with the ⁷/₁₆" wrench or socket. **Do not overtighten** as this may cause them to break!

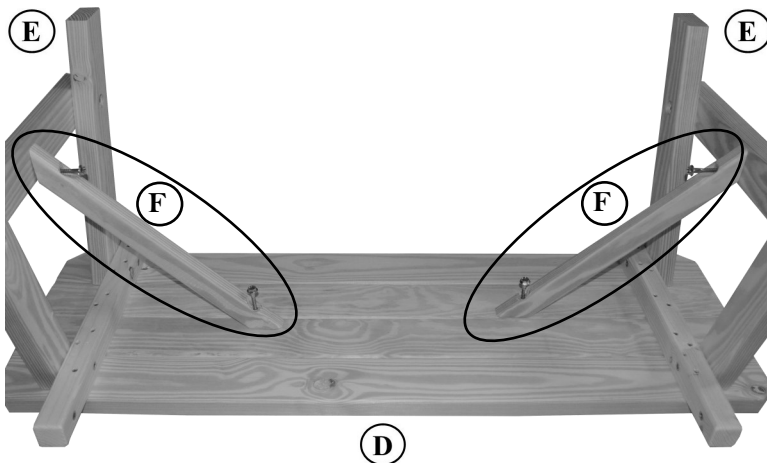

Photo 7

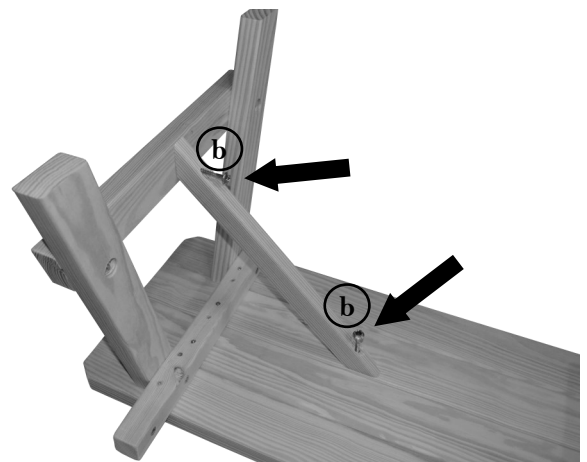

Photo 8

STEP 5

Set the bench upright. (If it rocks or seems unstable loosen the bolts, put some weight on it and retighten.) Take the bench back and attach it to the bench with the upright back supports outside of the bench 2x2's. (See photo 9.) Insert $2\frac{3}{4}$ " bolts through the holes in the back uprights and turn them into the metal inserts in the 2x2's. (See photo 10.) Tighten with the Allen wrench. **Do not overtighten.**

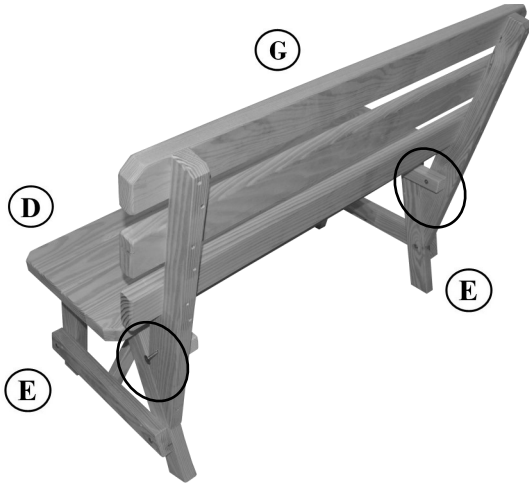

Photo 9

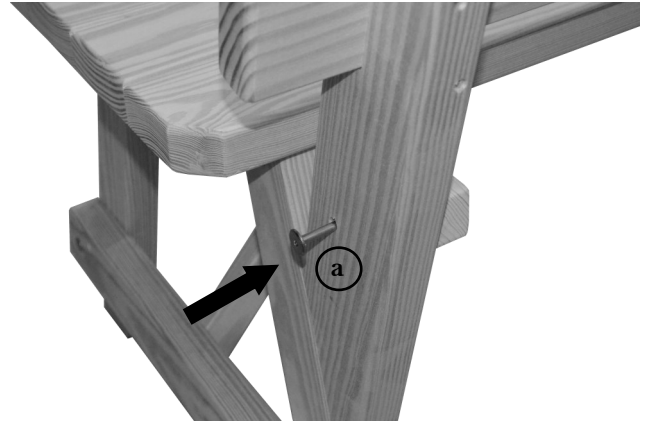

Photo 10

STEP 6

Insert $2\frac{1}{2}$ " lag screws through the predrilled holes in the back of the upright back supports. (See photos 11 and 12.) Tap them lightly with the hammer to start them into the bench leg. Tighten using the $\frac{7}{16}$ " wrench or socket. (They are self drilling and will not crack the wood.) **Do not overtighten** as this may cause them to break!

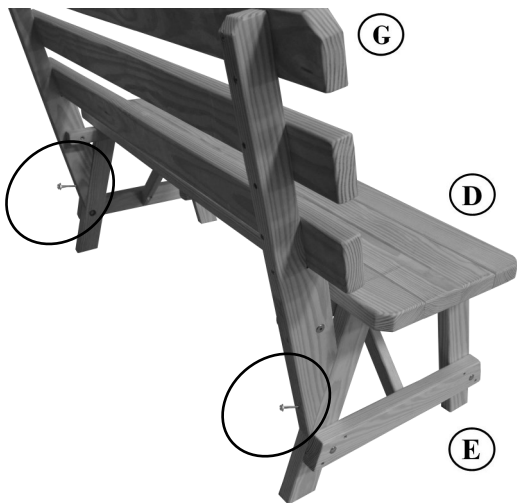

Photo 11

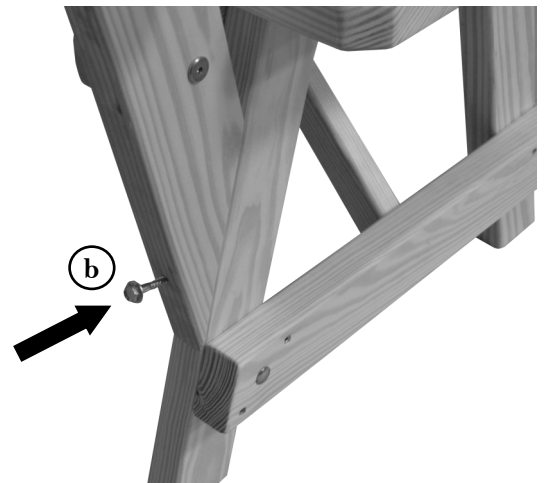

Photo 12

Repeat steps 3 through 6 for the other 3 benches.