

#### Required Tools:

- Mallet/Non Marring Hammer  
(Do not use Metal Headed Hammer)
- Cordless Drill
- #2 Square Drive bit
- 9/16" and 7/16" Wrench or Socket

#### Hardware:

- (4) 1/4" x 2" Bolts
- (2) 1/4" x 4" Bolts
- (2) 1/4" x 3 1/2" Bolts
- (8) 1/4" Flange Nuts
- (4) Glider Hangers
- (8) 3/8" x 2 1/2" Bolts
- (16) 3/8" Washers
- (8) 3/8" Locknuts
- (4) 1 1/4" Screws
- (8) 3" Screws

#### Parts:

- A = (1) Back
- B = (1) Seat
- C = (2) Arm-Leg Assembly
- D = (2) Glider Base Assembly
- E = (2) Base Support
- F = (1) Connector Block

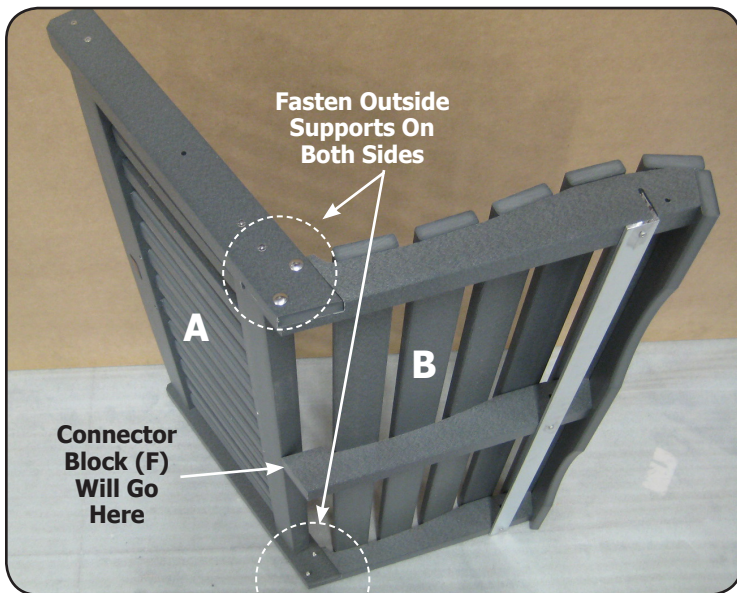

#### Step 1

Position seat (B) and back (A) and fasten outside supports with (4) 2" bolts & flange nuts on both sides as shown above. Use the 1/2" x 1 1/2" x 5" connector block (F) provided to fasten center seat support to the back using (4) 1 1/4" screws, as shown on right.

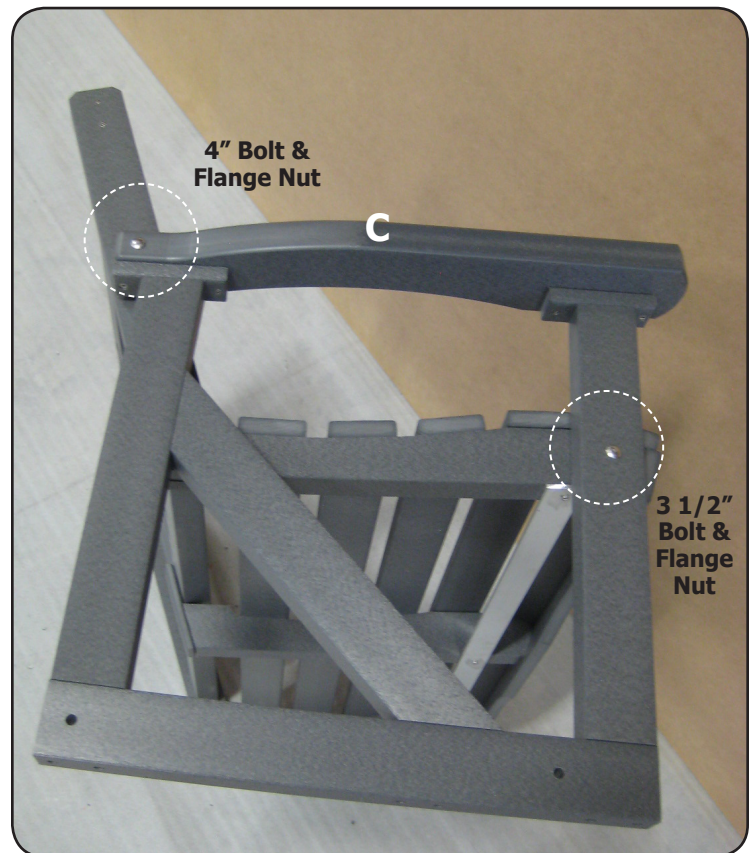
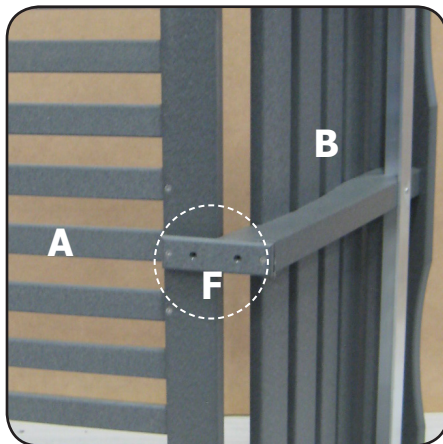

#### Step 2

Position the right arm-leg assembly (C) in position as shown and attach it to the seat/back assembly using a 4" bolt & a flange nut in the back and a 3 1/2" bolt & flange nut in the front. Repeat with the left arm-leg assembly.

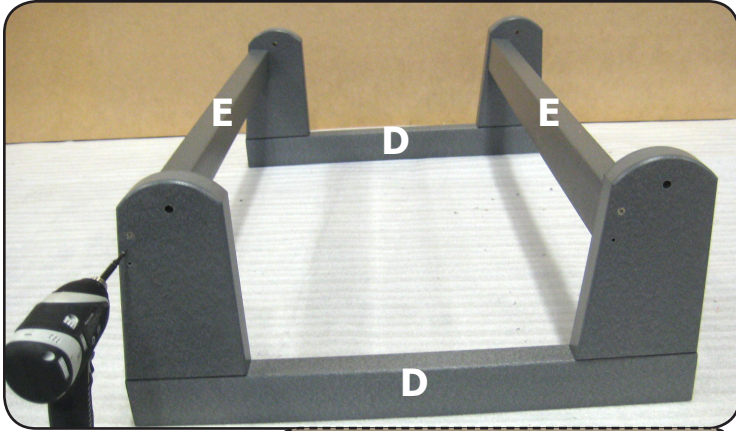

#### Step 3

Position both of the glider base assemblies (D), on a flat surface, as shown.

Attach both the base supports (E) as shown, keeping the base supports 1/8" in from the side (see inset) and fasten together with (8) 3" screws through counter sink holes provided.

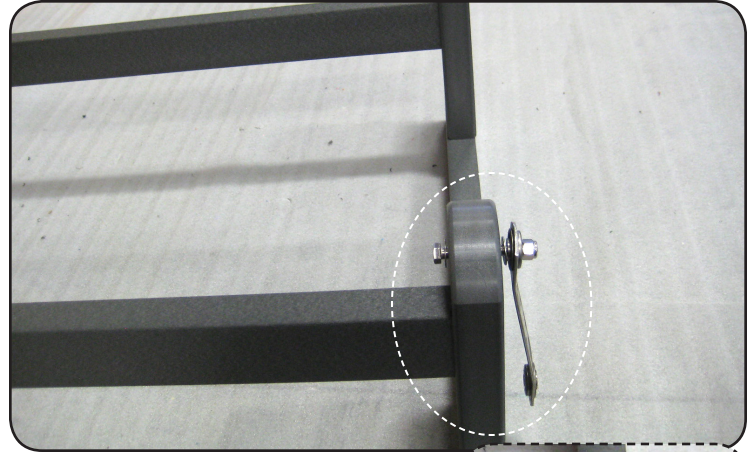
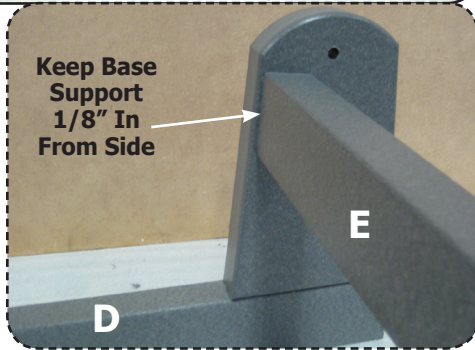

#### Step 4

Now mount (1) glider hanger onto base as shown, using (1) 3/8" x 2 1/2" bolt with (2) 3/8" washers. First slide a washer on bolt and push through hole provided from inside to outside. Add another washer then hang the glider hanger on bolt with curve away from bottom of base as shown. Now fasten with (1) 3/8" locknut tightly on bolt. Repeat other 3 sides.

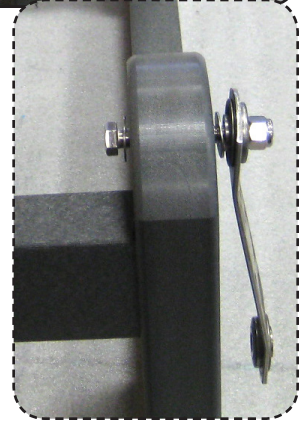

#### Step 5

Set the seat assembly over the base and fasten bottom of glider hangers to leg assembly (**Note: For the base piece - make sure the angled section goes towards the back of chair and straight section goes towards the front of chair, see inset below**) and attach with (1) 2 1/2" bolt, washers and locknuts, repeat on other 3 sides.

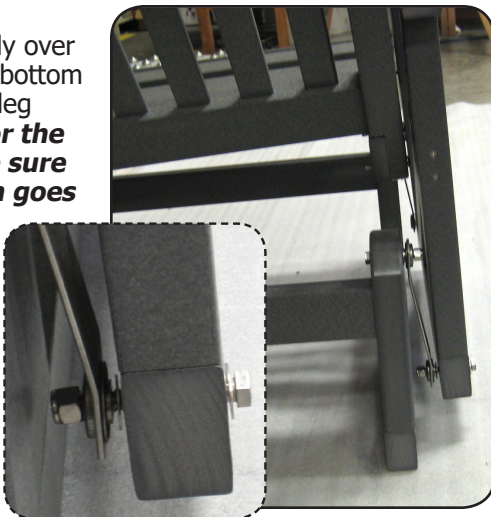

#### Step 6

Your bench is now complete.

*Thank you for purchasing from Wildridge.*