



Required Tools:

- Mallet/Non Marring Hammer
- Cordless Drill
- 1/2" and 9/16" Wrench or Socket
- #2 square drive bit

Hardware:

- (4) 5/16" x 5" Bolts
- (4) 5/16 x 3 1/2" Bolts
- (2) 1/4" x 4" Carriage Bolts
- (2) 1/4" Flange Nuts
- (8) 5/16 Flange Nuts
- (8) 3/8" x 2 1/2" Bolts
- (8) 3/8" Locknuts
- (16) 3/8" Washers
- (4) Glider Brackets
- (12) 2-1/2" Screws

Parts:

- A = (1) Backrest
- B = (1) Seat
- C = (1) Right Arm/Leg Assembly
- D = (1) Left Arm/Leg Assembly
- E = (2) Base Pieces
- F = (2) Cross Members

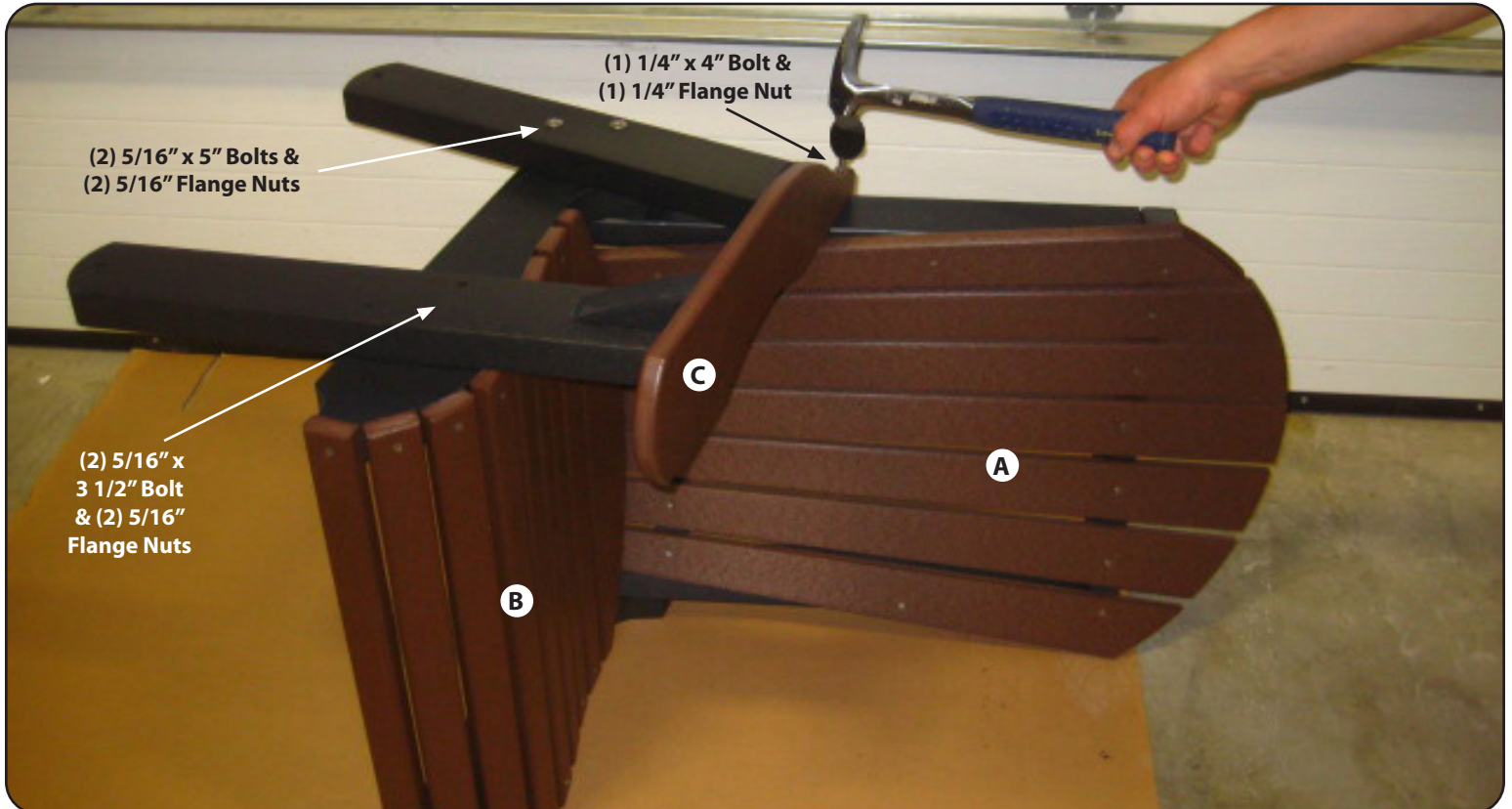

Step 1

On a level surface, place the backrest (A) and the seat (B) on its side, butting them up against each other. Lay the right arm/leg assembly (C) onto the backrest and seat and fasten them together. For the front leg use (2) 5/16" x 3 1/2" bolts and (2) 5/16" flange nuts. For the back leg use (2) 5/16" x 5" bolts & (2) 5/16" flange nuts, and for the armrest use (1) 1/4" x 4" bolt & (1) 1/4" flange nut. **DO NOT TIGHTEN NUTS AT THIS TIME.** Repeat with the left arm/leg assembly (D) on the other side. Tighten nuts.

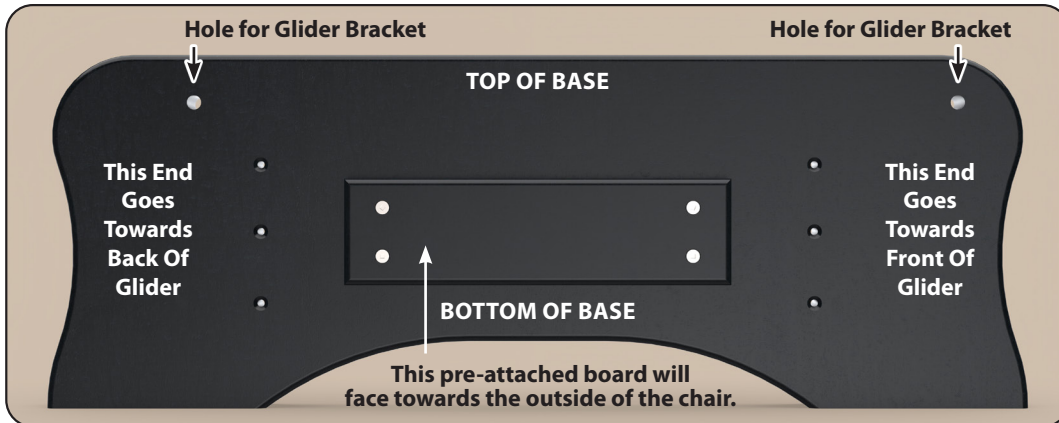

Step 2

Pictured top left is a single base piece to use as reference.

Please note the hole placement difference in the ends of both of the base pieces (E). Both base pieces will have the same hole configuration, and should be placed so the matching sides on the base pieces are both facing the same direction. Glider bracket hole closest to end of base goes towards the front of the glider and the other end will go towards the back of the glider.

The screws will go through the three holes that are to the left and three holes to the right of the pre-attached board on the base pieces. Do not put the screws in the holes on the top of the base pieces, those holes are for the glider bracket hardware used later.

Turn the base pieces (E) so the pre-attached boards face outward, then place the cross members (F) into the notches on the base and attach them using (12) 2-1/2" screws, six per side.

Note: As noted in first pic, the front of the base will be the front of the glider when you are assembling the base and glider in step 4.

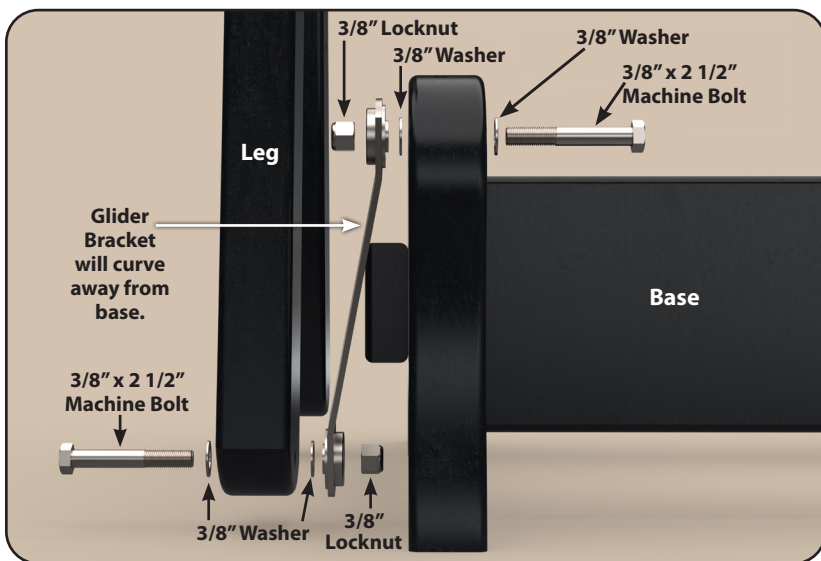
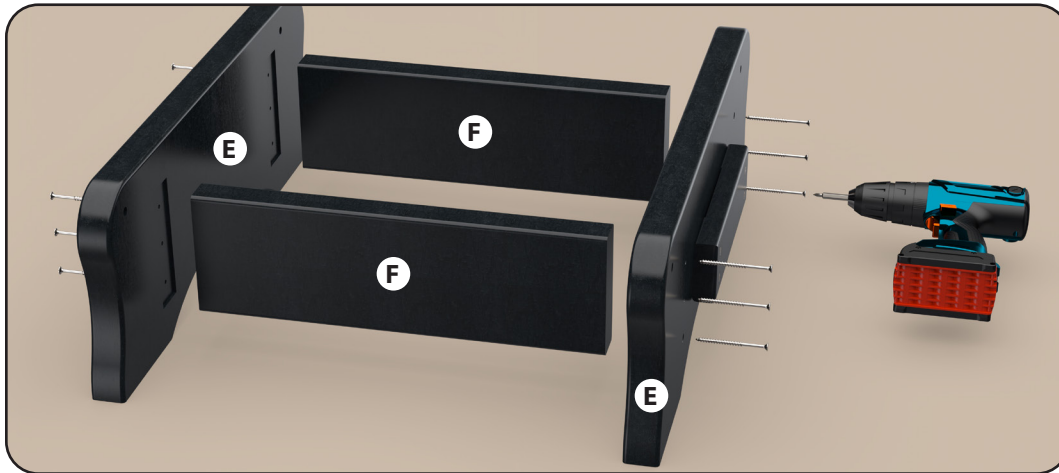

Step 3

You will need (1) glider bracket and the hardware: (2) 3/8"x2 1/2" machine bolts, (4) 3/8" washers and (2) 3/8" locknut. This will be for the installation of one glider bracket in the front of the glider.

Using the picture above left as a reference, install the hardware and glider bracket to the front of the base (note where the hole placement is to determine the front of the base as shown in step 3). For it to glide correctly the hardware must be placed in the order that is pictured above. Using the glider bracket and the hardware, install the hardware through the top hole of the glider base and fasten to the glider bracket in the order shown. Next, locate the glider assembly (seat/backrest/arm-leg assembly you put together earlier) and place it onto the base, as shown above right, then fasten the leg to the bottom of the glider bracket, installing the hardware in the order that is pictured above left. Repeat this same process on the remaining three legs. Your glider is now complete.